

Basic Concepts of Crystallography

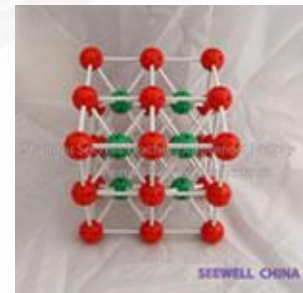

Language of Crystallography: Real Space

- Combination of local (point) symmetry elements, which include angular rotation, center-symmetric inversion, and reflection in mirror planes (total 32 variants), with translational symmetry (14 Bravais lattice) provides the overall crystal symmetry in 3D space that is described by 230 space group. Formula of crystallography:

Local (point)symmetry + translational symmetry → spatial symmetry

OR

32 Point groups + 14 Bravais lattice →230 space group

Unit Cell

- In 3D space the unit cells are replicated by three noncoplanar translation vectors \mathbf{a}_1 , \mathbf{a}_2 , \mathbf{a}_3 and the latter are typically used as the axes of coordinate system
- In this case the unit cell is a parallelepiped that is defined by length of vectors \mathbf{a}_1 , \mathbf{a}_2 , \mathbf{a}_3 and angles between them.

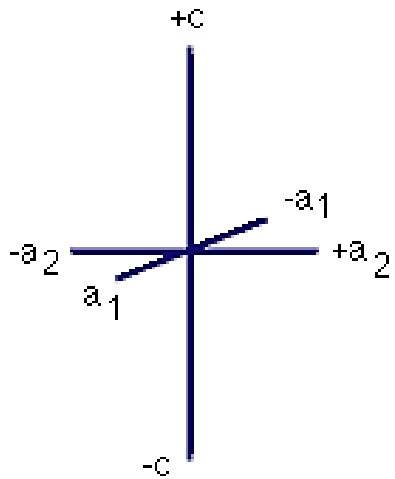

The volume of the parallelepiped is
Given by the mixed scalar-vector product
of translation vectors:

$$V = \mathbf{a}_1 \cdot [\mathbf{a}_2 \times \mathbf{a}_3]$$

Any point, \mathbf{r} , within a unit cell is defined
by three fractional coordinates, x, y, z :

$$\mathbf{r} = x\mathbf{a}_1 + y\mathbf{a}_2 + z\mathbf{a}_3$$

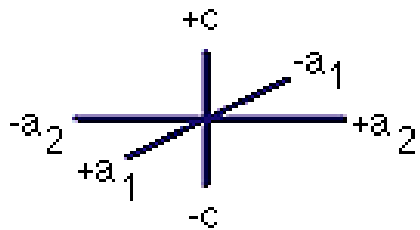
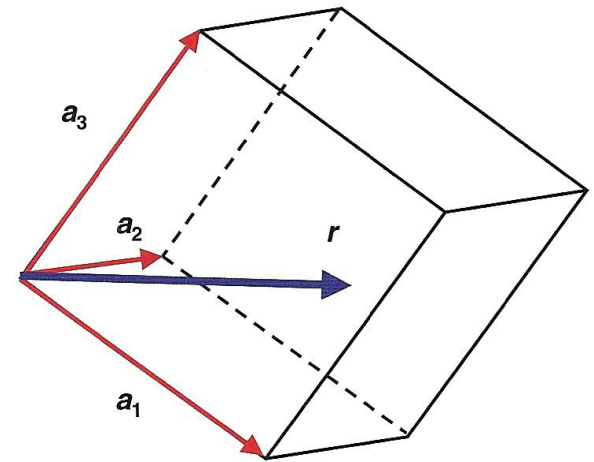

Indexing Crystal Points

In principle, atoms can occupy any partial position within the unit cell. However, there is a very restricted set of points, which can serve as symmetry elements. As a rule, these are the parallelepiped corners, $(0,0,0)$, the centers of its faces $(\frac{1}{2},\frac{1}{2},0)$, $(\frac{1}{2},0,\frac{1}{2})$, $(0,\frac{1}{2},\frac{1}{2})$, the center of the unit cell, $(\frac{1}{2},\frac{1}{2},\frac{1}{2})$, or points equally displaced from other points of high symmetry, for example, $(\frac{1}{4},\frac{1}{4},\frac{1}{4})$. In crystals of rhombohedral (trigonal) or hexagonal symmetries, containing regular triangles as a 2D symmetry motif, the center of such a triangle is a highly symmetric point with coordinates $(\frac{2}{3},\frac{1}{3},0)$ or $(\frac{1}{3},\frac{2}{3},0)$. In order to obtain the latter coordinates, we draw lines parallel to our coordinate axes and passing through the center of the triangle (see Figure 2.2). Then we recall well-known geometrical result that at the center of a regular triangle the heights of the triangle are divided in proportion 2 : 1.

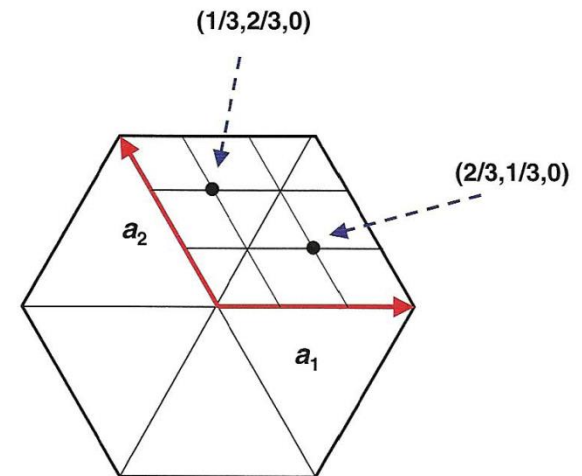
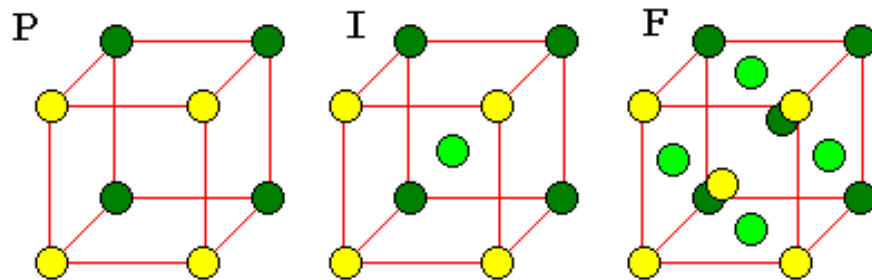

Point Coordinates

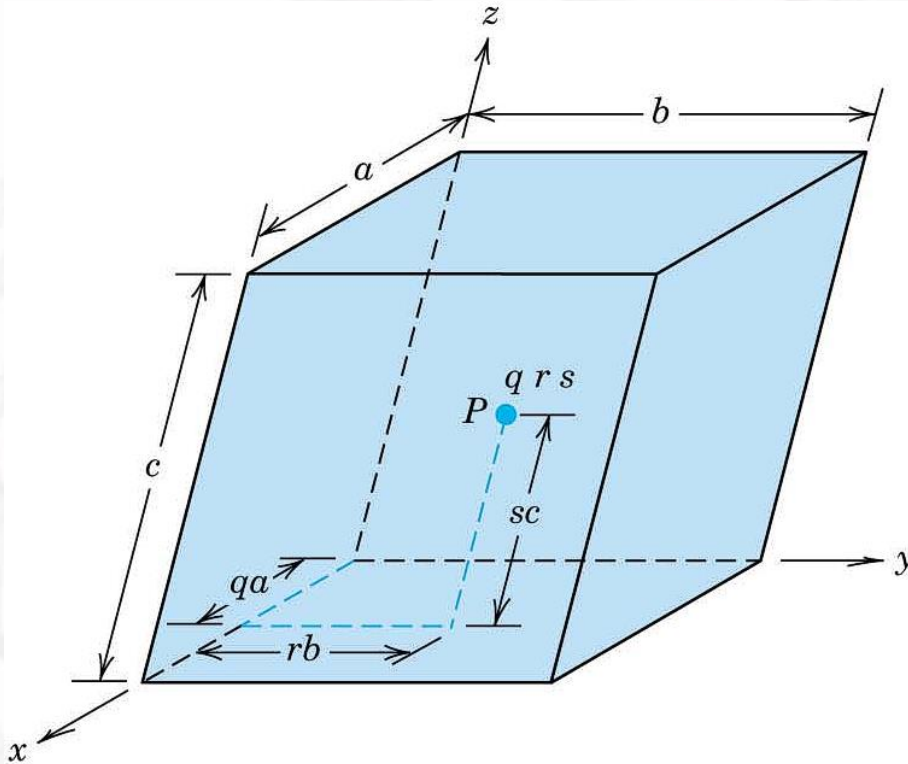

The position of any point (e.g. P) within the unit cell can be defined in terms of **generalized coordinates** (e.g. q, r, s) which are **fractional multiples** of the unit cell **edge length** (a, b, c respectively): **($q\ r\ s$)**

Point Coordinates

Problem: Locate the point with coordinates $\frac{1}{4}, 1, \frac{1}{2}$

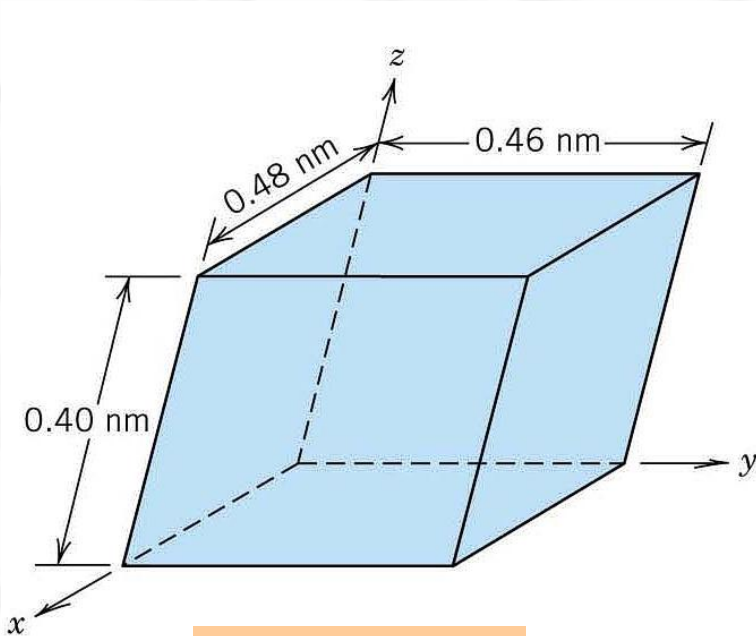

$a = 0.48 \text{ nm}$
 $b = 0.46 \text{ nm}$
 $c = 0.40 \text{ nm}$

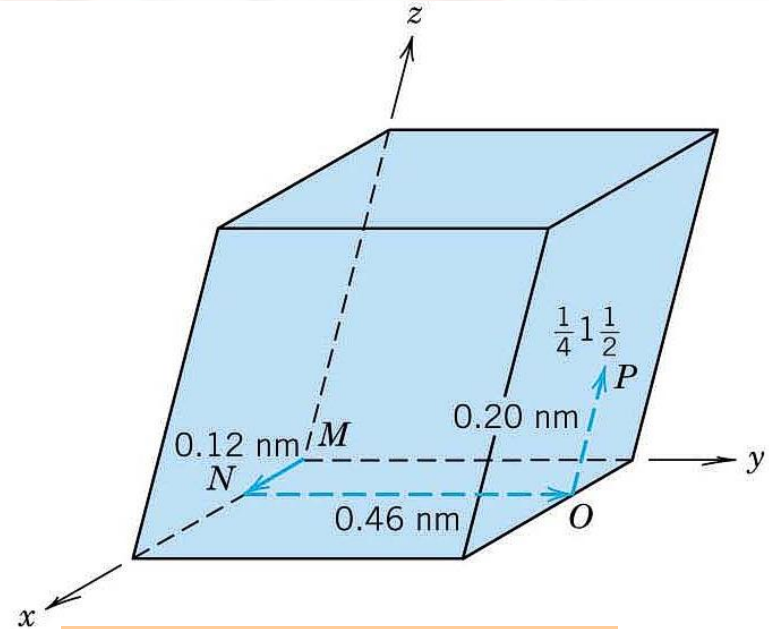

$P: q r s = P: \frac{1}{4} 1 \frac{1}{2}$
 $qa = \frac{1}{4} 0.48 \text{ nm} = 0.12 \text{ nm}$
 $rb = 0.46 \text{ nm}$
 $sc = \frac{1}{2} 0.40 \text{ nm} = 0.20 \text{ nm}$

Indexing Crystal Points

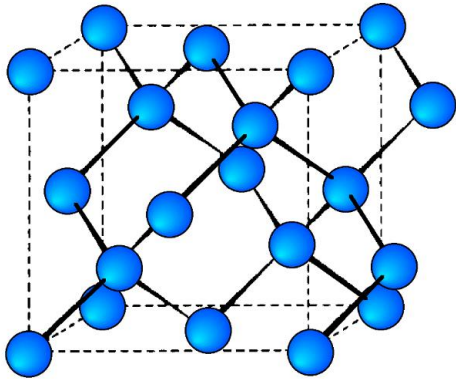

First of all, one set of carbon atoms occupy all corner positions of the cubic unit cell; the coordinates of these atoms are as follows: 000, 100, 110, 010, 001, 101, 111, and 011.

Another set of atoms reside on all of the face-centered positions, with the following coordinates: $\frac{1}{2}\frac{1}{2}0$, $\frac{1}{2}\frac{1}{2}1$, $1\frac{1}{2}\frac{1}{2}$, $0\frac{1}{2}\frac{1}{2}$, $\frac{1}{2}0\frac{1}{2}$, and $\frac{1}{2}1\frac{1}{2}$.

The third set of carbon atoms are positioned within the interior of the unit cell. Using an x - y - z coordinate system oriented as in Figure : the coordinates of the atom that lies toward the lower-left-front of the unit cell has the coordinates $\frac{3}{4}\frac{1}{4}\frac{1}{4}$, whereas the atom situated toward the lower-right-back of the unit cell has coordinates of

$\frac{1}{4}\frac{3}{4}\frac{3}{4}$. Also, the carbon atom that resides toward the upper-left-back of the unit cell has the $\frac{1}{4}\frac{1}{4}\frac{3}{4}$ coordinates.

And, the coordinates of the final atom, located toward the upper-right-front of the unit cell, are $\frac{3}{4}\frac{3}{4}\frac{1}{4}$.

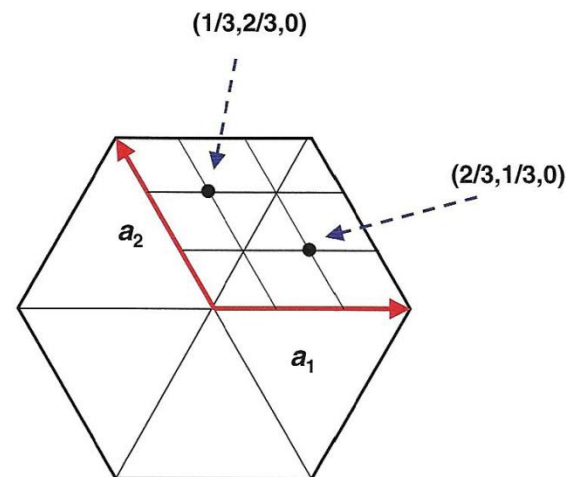
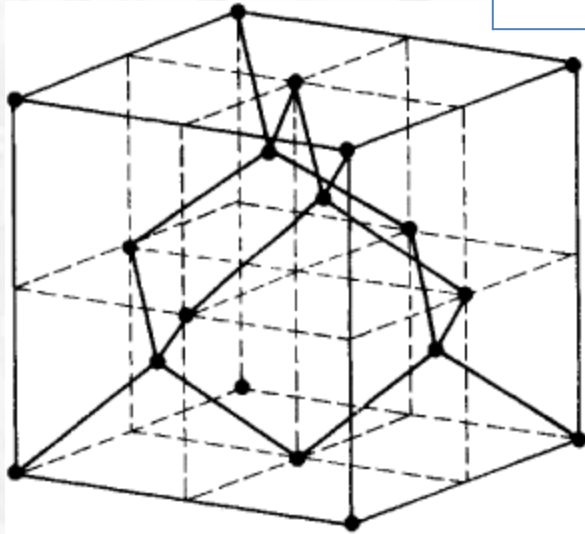

Indexing Crystallographic Directions

Such symmetry elements as rotation axes are associated with certain crystallographic directions. The latter also designated by vector, \mathbf{r} :

$$\mathbf{r} = u\mathbf{a}_1 + v\mathbf{a}_2 + w\mathbf{a}_3$$

but this time with integer numbers standing for projections along the translation vectors. In fact, within a 3D network, to which individual unit cells belong, the meaningful crystallographic directions are those connecting the network nodes. Since, the origin of our coordinate system is naturally at node (0,0,0), Equation simply reflects the fact that vector \mathbf{r} passes at least through one additional node of the network, which is expressed as a linear combination of translation vectors. Also in this case, the concise record for vector \mathbf{r} , namely $[u \ v \ w]$, is in common use.

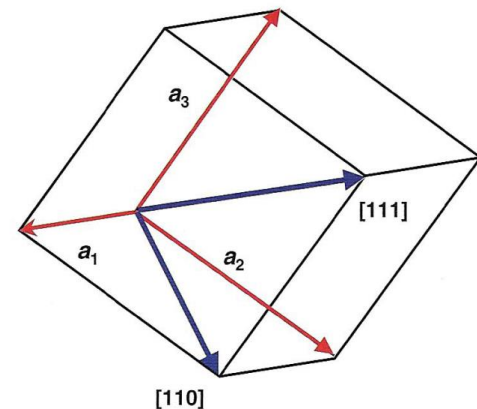
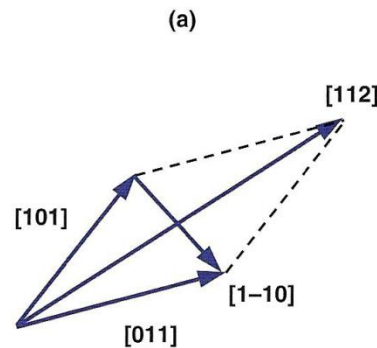
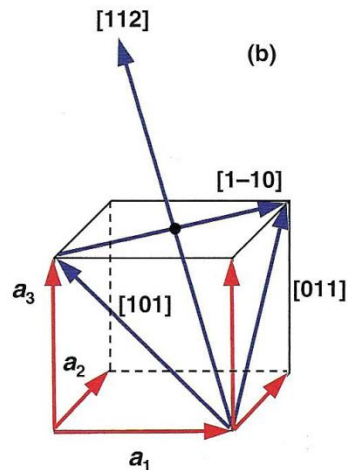

Indexing Crystallographic Directions

Linear combinations of different vectors r are also lattice vectors. By using concise record we can simply summate corresponding indices u, v, w in order to indicate these combinations. For example, the spatial diagonal of any parallelepiped, is expressed as $[111] = [100] + [010] + [001]$, while its face diagonals are $[110] = [100] + [010]$, $[011] = [010] + [001]$, and $[101] = [100] + [001]$, independently of the unit cell's symmetry (see Figure). The vector composed of two face diagonals situated in two nonparallel faces, say the diagonals $[101]$ and $[011]$, is $[112] = [101] + [011]$, while their difference, $[1-10]$, belongs to the set of the face diagonals (see Figure). For diagonals situated within the same face, say $[110]$ and $[1-10]$, similar procedures produce vectors parallel to the parallelepiped edges, $[200]$ and $[020]$ (see Figure).

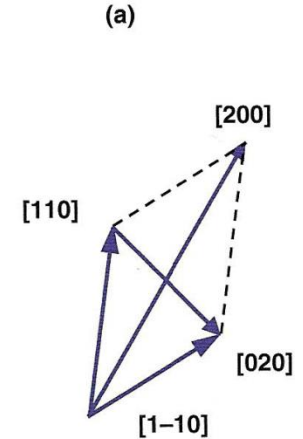
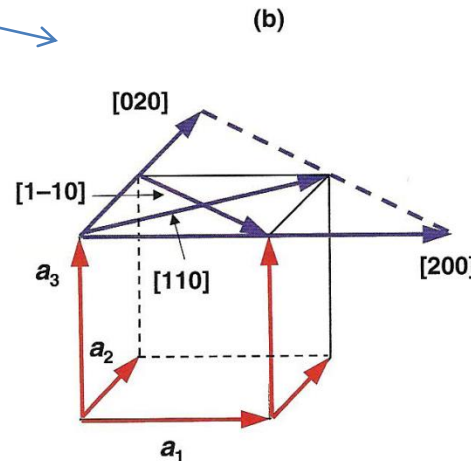
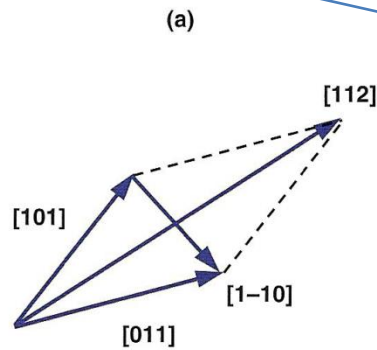
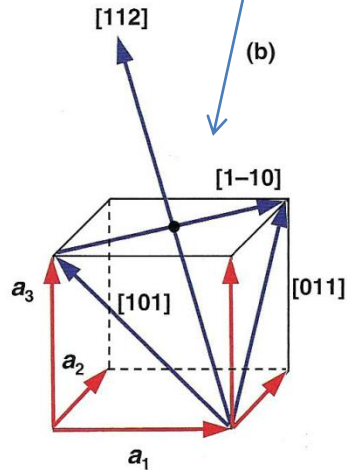
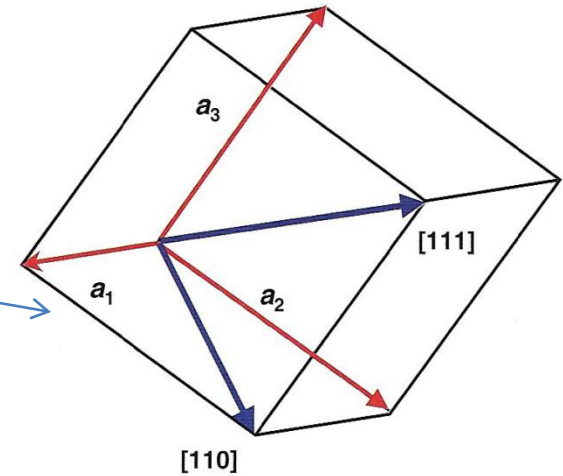

(a) Crystallographic directions, the $[112]$ and $[1-10]$ as produced by vector summation of certain face diagonals
 (b) Arrangement of these vectors in 3D space

(a) Crystallographic directions, the $[200]$ and $[020]$ as produced by vector summation of certain face diagonals
 (b) Arrangement of these vectors in 3D space

Crystallographic Directions

is a **vector** connecting the coordinate origin and a specific point of a unit cell. In crystallography such vector is defined by **three directional indices [u v w]**

Rules for indexes determination:

1. A vector of desired length is positioned that it pass through the origin of the coordinate system. ***Translate it through a crystal lattice if needed!!***

2. The length of the vector projection on each axis are determined again ***in terms of unit cell dimensions*** (a, b, c)

3. Obtained three numbers are multiplied or divided by a common factor to reduce them to **integer values (e.g. u v and w)**

4. Notation in **square bracket [u v w]** defines the desired crystallographic direction

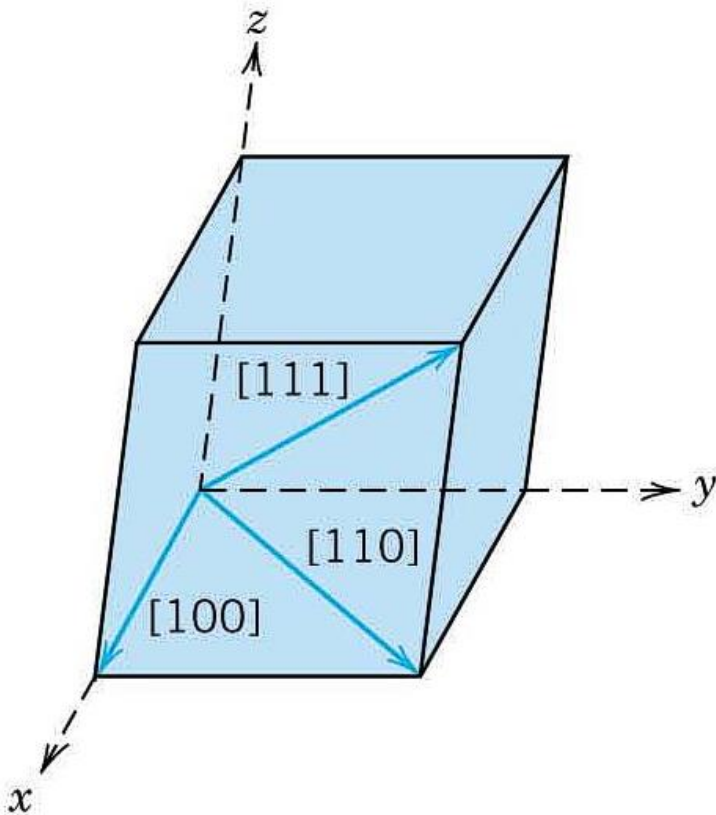

Indexing Crystallographic Directions

Or
$$u = n \left(\frac{x_2 - x_1}{a} \right)$$

$$v = n \left(\frac{y_2 - y_1}{b} \right)$$

$$w = n \left(\frac{z_2 - z_1}{c} \right)$$

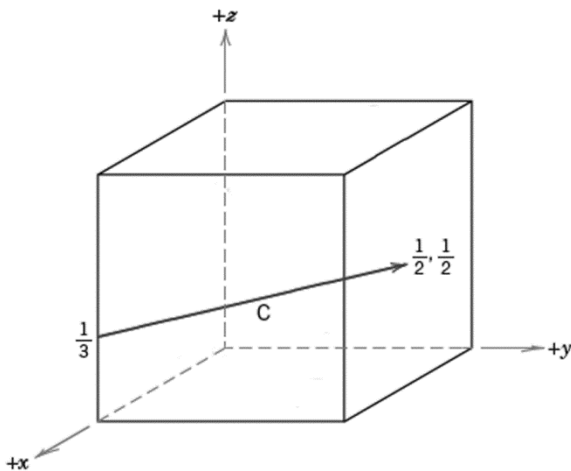
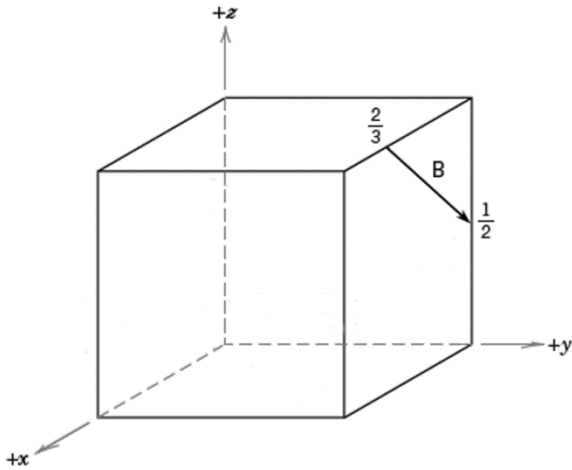

Indexing Crystallographic Directions Hexagonal System

The hexagon edge (X-direction) is parallel to the translation vector \mathbf{a}_1 , That is $\mathbf{r} = \mathbf{a}_1$, hence is along the [100] – direction. For Y – direction $\mathbf{r} = \mathbf{a}_1 + 2 \mathbf{a}_2$ that is [120]-direction

Set of translation vectors $\mathbf{a}_1, \mathbf{a}_2, \mathbf{a}_s$ in the hexagonal (basal) plane used for the four-digit indexing of crystallographic directions hexagonal crystal

$$\mathbf{r} = u\mathbf{a}_1 + v\mathbf{a}_2 + w\mathbf{a}_3$$

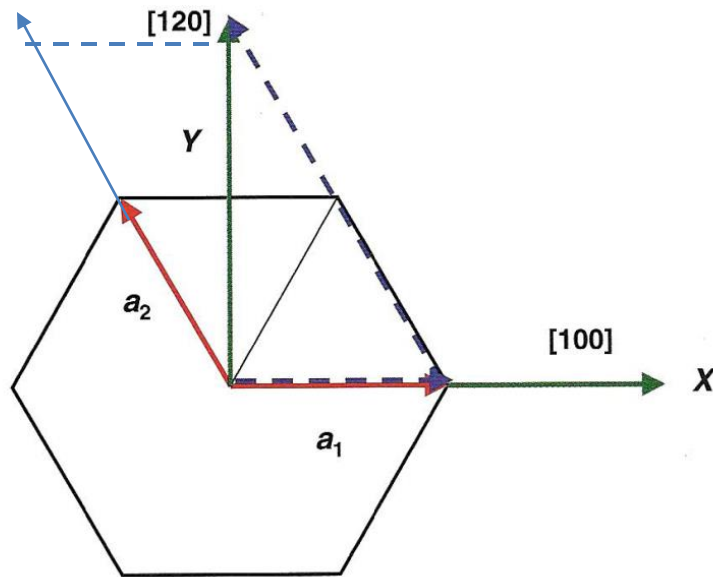

Indexing crystallographic directions in the hexagonal (basal) plane of hexagonal crystal

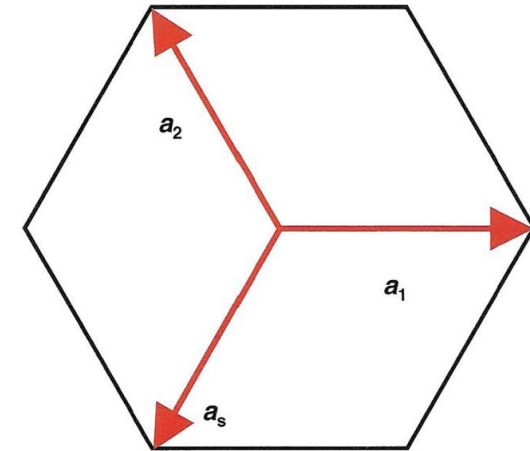

The system is based on four translation vectors, three of them being in the hexagon plane (i.e. $\mathbf{a}_1, \mathbf{a}_2, \mathbf{a}_s$) and the fourth one, \mathbf{a}_3 , perpendicular to it.

$$\mathbf{r} = u\mathbf{a}_1 + v\mathbf{a}_2 + s\mathbf{a}_s + w\mathbf{a}_3$$

Definitely, three projections in the hexagon plane, u, v and s are no longer independent. This follows from relationship:

$$\mathbf{a}_1 + \mathbf{a}_2 + \mathbf{a}_s = 0$$

e.g. [120] –direction $\rightarrow [0,1,-1,0]$

Crystallographic Directions: *Hexagonal Crystals*

It is convenient to use a **four-axis** (Miller-Bravais) coordinate system: $\mathbf{a}_1, \mathbf{a}_2, \mathbf{a}_3$ axes lay in one **basal** plane and located at 120° to each other, while the **z** axis is perpendicular to the basal plane.

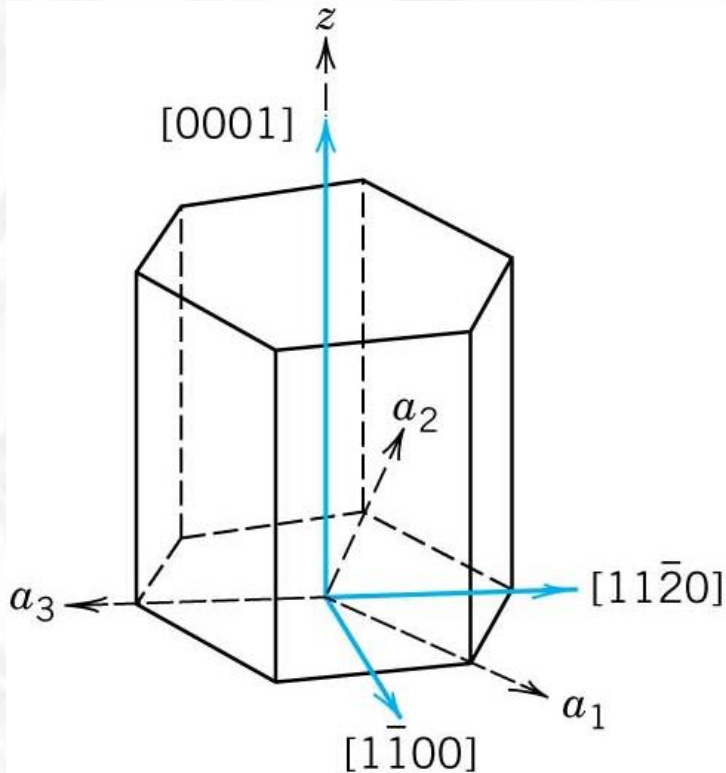

Same rules determine in this case four indices $[u\ v\ s\ w]$: by convention the first three pertain to projections in $\mathbf{a}_1, \mathbf{a}_2, z$ axes

$[u'\ v'\ w'] \rightarrow [u\ v\ s\ w]$ conversion:

$$\begin{aligned} u &= n/3 \cdot (2u' - v') \\ v &= n/3 \cdot (2v' - u') \\ s &= -(u + v) \\ w &= n w' \end{aligned}$$

where n is a factor required to reduce indices to integer numbers

Indexing Crystallographic Directions

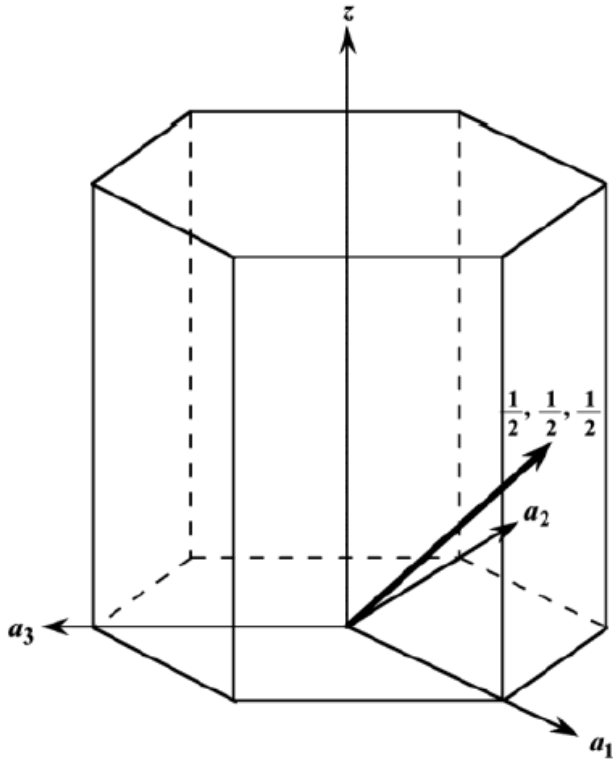

For this direction, projections on the a_1 , a_2 , and z axes are a , $a/2$, and $c/2$, or, in terms of a and c the projections are 1, $1/2$, and $1/2$, which when multiplied by the factor 2 become the smallest set of integers: 2, 1, and 1. This means that

$$u' = 2$$

$$v' = 1$$

$$w' = 1$$

Now, from Equations from the previous slide, the u , v , t , and w indices become

$$u = n/3 \cdot (2u' - v')$$

$$v = n/3 \cdot (2v' - u')$$

$$s = - (u + v)$$

$$w = n w'$$

No reduction is necessary inasmuch as all of these indices are integers; therefore, this direction in the four-index scheme is $[10\bar{1}1]$

Language of Crystallography: Reciprocal space

- **Symmetry elements of the third type, crystallographic planes**, are indexed in a unusual way. For this purpose, a new space with three basis vectors $\mathbf{b}_1, \mathbf{b}_2, \mathbf{b}_3$, is created, which is orthogonal to real space.

$$\mathbf{a}_i \cdot \mathbf{b}_k = \delta_{ik}$$

where the δ_{ik} is the Kronecker symbol $\delta_{ik} = 0$ if $i \neq k$ and 1 if $i = k$.

- This new space is called **reciprocal space**. To built reciprocal space starting from real space, which is defined by vectors $\mathbf{a}_1, \mathbf{a}_2, \mathbf{a}_3$ the following mathematical operations is used:

$$\mathbf{b}_1 = [\mathbf{a}_2 \times \mathbf{a}_3] / V$$

$$\mathbf{b}_2 = [\mathbf{a}_3 \times \mathbf{a}_1] / V$$

$$\mathbf{b}_3 = [\mathbf{a}_1 \times \mathbf{a}_2] / V$$

Please prove that thus introduced system fits orthogonal conditions above.

Also prove that the following relation between the volumes in reciprocal (V_r) and real (V) spaces stands:

$$V_r = \mathbf{b}_1 \cdot [\mathbf{b}_2 \times \mathbf{b}_3] = V^{-1}$$

Reciprocal and Real Spaces

Let us illustrate the construction of reciprocal space by selected examples. For cubic crystals, the basis vectors in real space have equal lengths, $|\mathbf{a}_1| = |\mathbf{a}_2| = |\mathbf{a}_3| = a_0$, and angles between them, $\alpha = \beta = \gamma = 90^\circ$.

Using equations:

$$\mathbf{b}_1 = [\mathbf{a}_2 \times \mathbf{a}_3]/V$$

$$\mathbf{b}_2 = [\mathbf{a}_3 \times \mathbf{a}_1]/V \quad V = \mathbf{a}_1 \cdot [\mathbf{a}_2 \times \mathbf{a}_3]$$

$$\mathbf{b}_3 = [\mathbf{a}_1 \times \mathbf{a}_2]/V$$

yields $|\mathbf{b}_1| = |\mathbf{b}_2| = |\mathbf{b}_3| = 1/a_0$ and each vector \mathbf{b}_i is parallel to the corresponding vector \mathbf{a}_i .

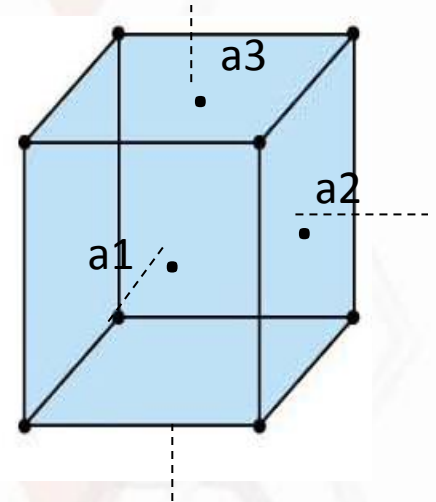

- Note that in crystallography only the relationship between vectors make sense, rather than their absolute values.
- Since **for cubic symmetry** the triads of basis vectors in both spaces have equal lengths and 90 angles between them **the real and reciprocal spaces are coincide.** It is worth noting that **this is a unique situation.**
- **For lower symmetries these spaces are different, independently how small a distortion is.**

Reciprocal and Real Spaces: Example

Let us for example apply the tensile deformation to a cubic crystal along one of its axes (e.g. \mathbf{a}_3). Under this deformation the cubic unit cell transforms into tetragonal prism with $|\mathbf{a}_3| = c > 1$. The angles between the prism edges remain at 90° .

In the reciprocal space we have $|\mathbf{b}_1| = |\mathbf{b}_2| = 1/a$, while $|\mathbf{b}_3| = 1/c$. Vectors $\mathbf{b}_1, \mathbf{b}_2, \mathbf{b}_3$ are parallel to vectors $\mathbf{a}_1, \mathbf{a}_2, \mathbf{a}_3$ respectively. So, in the reciprocal space the unit cell is again the tetragonal prism, but differing from one in real space by the tetragonality parameter, which is now $a/c < 1$.

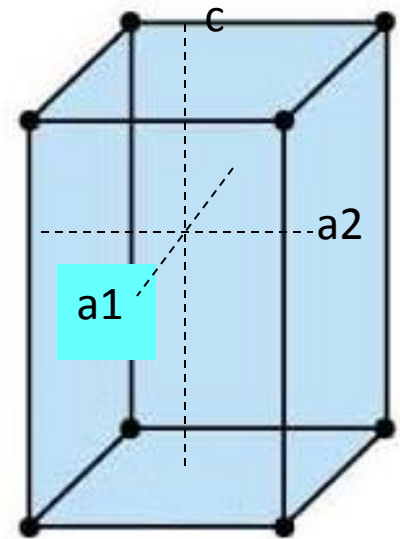
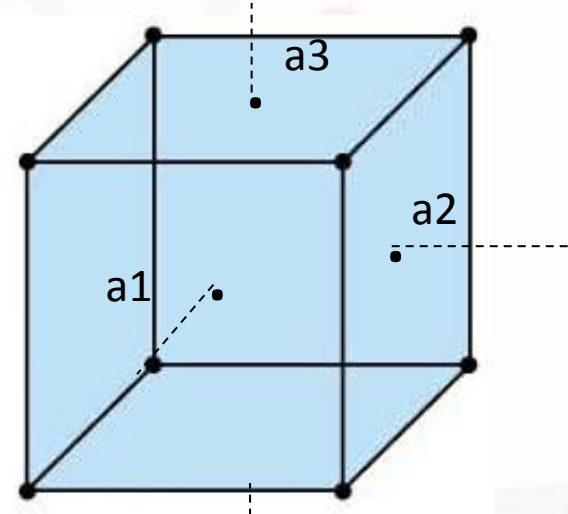

Reciprocal and Real Spaces: Example

Symmetries, in which the angles between the basis vectors differ from 90° , require more careful consideration.

For example in hexagonal crystal the basis vectors in the basal plane are equal to each other $|\mathbf{a}_1| = |\mathbf{a}_2| = a$, and the angle between them is $\gamma = 120^\circ$. The third vector is normal to hexagon plane ($\alpha = \beta = 90^\circ$), but has a different length $|\mathbf{a}_3| = c$.

In reciprocal space vector \mathbf{b}_3 is parallel \mathbf{a}_3 and its length $|\mathbf{b}_3| = 1/c$. Vectors \mathbf{b}_1 and \mathbf{b}_2 are as shown in Figure with their lengths being $|\mathbf{b}_1| = |\mathbf{b}_2| = 2/(\sqrt{3} \cdot a)$ and angles between them is 60° .

$$\mathbf{b}_1 = [\mathbf{a}_2 \times \mathbf{a}_3] / V$$

$$\mathbf{b}_2 = [\mathbf{a}_3 \times \mathbf{a}_1] / V$$

$$\mathbf{b}_3 = [\mathbf{a}_1 \times \mathbf{a}_2] / V$$

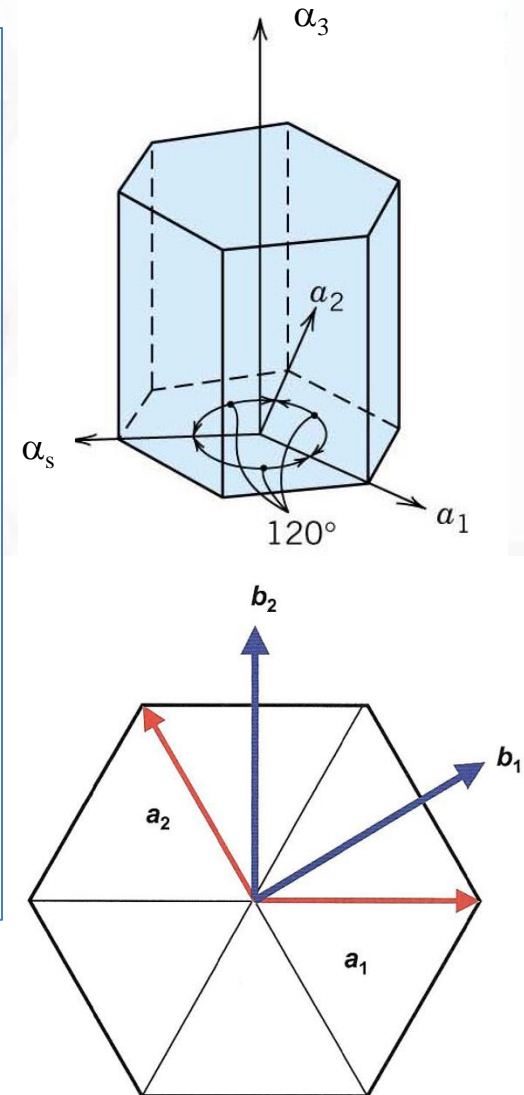

Reciprocal and Real Spaces

$$\mathbf{b}_1 = [\mathbf{a}_2 \times \mathbf{a}_3]/V$$

$$\mathbf{b}_2 = [\mathbf{a}_3 \times \mathbf{a}_1]/V$$

$$\mathbf{b}_3 = [\mathbf{a}_1 \times \mathbf{a}_2]/V$$

$$V = \mathbf{a}_1 \cdot [\mathbf{a}_2 \times \mathbf{a}_3]$$

Vector, \mathbf{H} , belongs to reciprocal space and are combination of basis vectors, $\mathbf{b}_1, \mathbf{b}_2, \mathbf{b}_3$:

$$\mathbf{H} = h\mathbf{b}_1 + k\mathbf{b}_2 + l\mathbf{b}_3$$

with integer projection (h,k,l) which are called the Miller indices

- Vectors \mathbf{H} represent different crystallographic planes.
- Why do we need so extravagant way of representation of crystallographic planes?
- Briefly, this representation is very well suited for analyzing the diffraction conditions in crystal for calculating the phase of the waves, scattered by atomic plane

In order to understand the interrelation between vectors \mathbf{H} and crystallographic planes, we need first to define the latter in real space. For further analysis it is most appropriate to define specific crystallographic plane via segments, $\mathbf{OA} = x_0\mathbf{a}_1$, $\mathbf{OB} = y_0\mathbf{a}_2$, $\mathbf{OC} = z_0\mathbf{a}_3$, which it cuts on the axes of the coordinate system (see Figure). Vectors $\mathbf{AB}, \mathbf{BC}, \mathbf{AC}$, located within the plane, are expressed as:

$$\mathbf{AB} = y_0\mathbf{a}_2 - x_0\mathbf{a}_1$$

$$\mathbf{BC} = z_0\mathbf{a}_3 - y_0\mathbf{a}_2$$

$$\mathbf{AC} = z_0\mathbf{a}_3 - x_0\mathbf{a}_1$$

By using equations:

$$\mathbf{H} = h\mathbf{b}_1 + k\mathbf{b}_2 + l\mathbf{b}_3$$

$$\mathbf{a}_i \cdot \mathbf{b}_k = \delta_{ik}$$

Show that scalar products of vector \mathbf{H} and $\mathbf{AB}, \mathbf{BC}, \mathbf{AC}$ equal:

$$\mathbf{H} \cdot \mathbf{AB} = k \cdot y_0 - h \cdot x_0$$

$$\mathbf{H} \cdot \mathbf{BC} = l \cdot z_0 - k \cdot y_0$$

$$\mathbf{H} \cdot \mathbf{AC} = l \cdot z_0 - h \cdot x_0$$

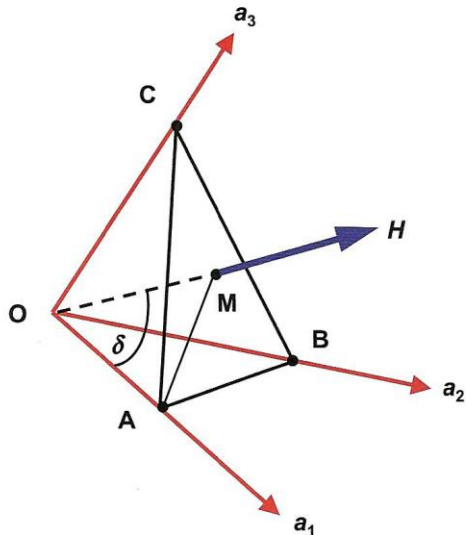

Reciprocal and Real Spaces

In order to understand the interrelation between vectors H and crystallographic planes, we need first to define the latter in real space. For further analysis it is most appropriate to define specific crystallographic plane via segments, $OA = x_0 a_1$, $OB = y_0 a_2$, $OC = z_0 a_3$, which it cuts on the axes of the coordinate system (see Figure 3.2). Vectors AB , BC , AC , located within the plane, are expressed as:

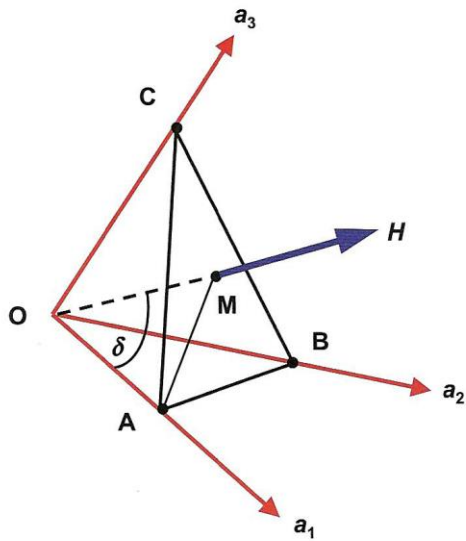

$$AB = y_0 a_2 - x_0 a_1$$

$$BC = z_0 a_3 - y_0 a_2$$

$$AC = z_0 a_3 - x_0 a_1$$

By using equations:

$$H = h b_1 + k b_2 + l b_3$$

$$a_i \cdot b_k = \delta_{ik}$$

It can be shown that scalar products of vector H and AB, BC, AC equal:

$$H \cdot AB = k \cdot y_0 - h \cdot x_0$$

$$H \cdot BC = l \cdot z_0 - k \cdot y_0$$

$$H \cdot AC = l \cdot z_0 - h \cdot x_0$$

$$h = 1/x_0$$

$$k = 1/y_0$$

$$l = 1/z_0$$

Now by setting:

The scalar products $H \cdot AB = H \cdot BC = H \cdot AC = 0$
 which means that **vector H** is normal to **AB, BC, AC**
 and hence **normal to the crystallographic plane**

Vector H

- In diffraction applications not only is the direction of vector of reciprocal lattice H of great importance but also its length, which is reciprocal to the length of the normal to the crystallographic plane, counted from the origin of the coordinate system (segment OM).
- This distance is called the d -spacing that is the spacing between parallel planes taking in the diffraction processes of e.g. electrons:

$$d = |\mathbf{H}|^{-1}$$

To prove that recall that $\mathbf{OA} = \mathbf{a}_1/h$, and $\mathbf{H} = h\mathbf{b}_1 + k\mathbf{b}_2 + l\mathbf{b}_3$
In this case scalar product $\mathbf{H} \cdot \mathbf{OA}$ is:

$$\mathbf{H} \cdot \mathbf{OA} = |\mathbf{H}| |\mathbf{a}_1| \frac{\cos \delta}{h} = (h\mathbf{b}_1 + k\mathbf{b}_2 + l\mathbf{b}_3) \cdot (\mathbf{a}_1/h) = 1$$

where δ is the angle between the normal to the crystallographic plane and vector \mathbf{a}_1 .
Since OM is parallel to vector \mathbf{H} , we can also find the value of $\cos \delta$ from triangle AOM :

$$\cos \delta = OM/OA = d h / |\mathbf{a}_1|$$

$$\text{Thus: } d = |\mathbf{H}|^{-1}$$

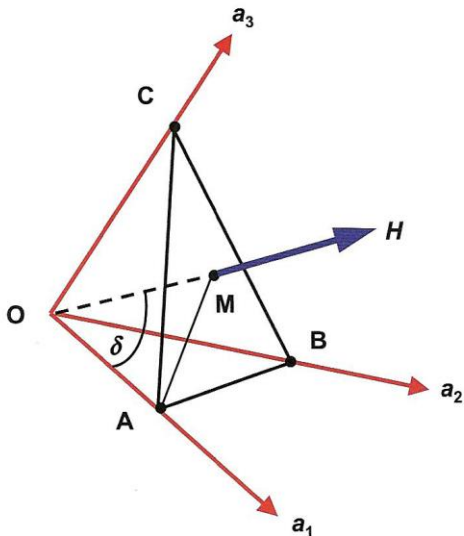

Reciprocal and Real Spaces

$$h = 1/x_0$$

$$k = 1/y_0$$

$$l = 1/z_0$$

$$H = hb_1 + kb_2 + lb_3$$

In order to attribute vector H to a certain plane, one has to find the segments that this plane cuts on the edges of the unit cell in real space, and then convert them to Miller indices by using Equations. The normal to the plane is given by vector H and the concise plane indexing is simply (hkl) .

• **Note that this procedure is applicable to every crystal independently of its symmetry.**

For example, the crystallographic plane parallel to a_3 -translation and passing through the diagonal, which connects vectors a_1 a_2 -is **always** (110) and passing through the ends of vectors a_1 a_2 a_3 is **always** the (111) plane.

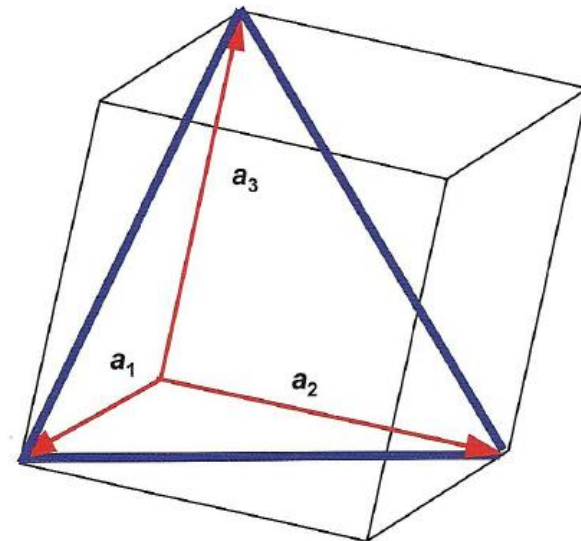
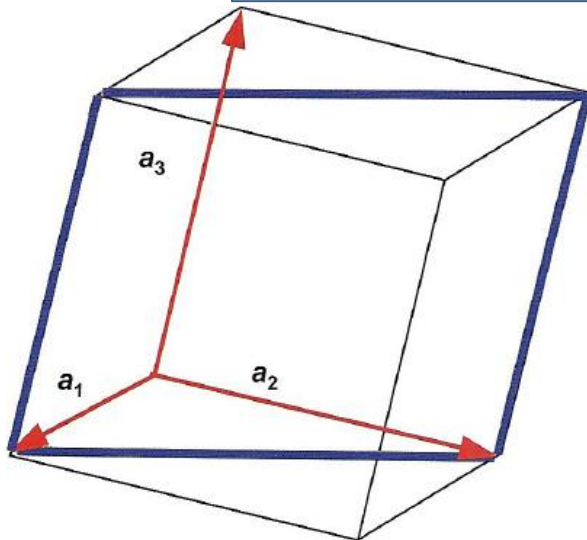

Crystallographic Planes

Crystallographic planes are typically specified by **three Miller indices (hkl)**

Rules for indexes determination:

1. If the plane passes through the origin, or another plane must be constructed by appropriate parallel translation or new origin must be selected at the corner of the another unit cell.
2. After such operation, the plane either intersects or // to the axes and the length of The planar intercept each axes is determined in *term of lattice parameters a, b and c.*
3. The **reciprocal** of these number are taken
4. If necessary these numbers are reduced to the set of **smallest integers (e.g. h,k,l)**
5. These integers in parentheses **(hkl)** represent the crystallographic plane

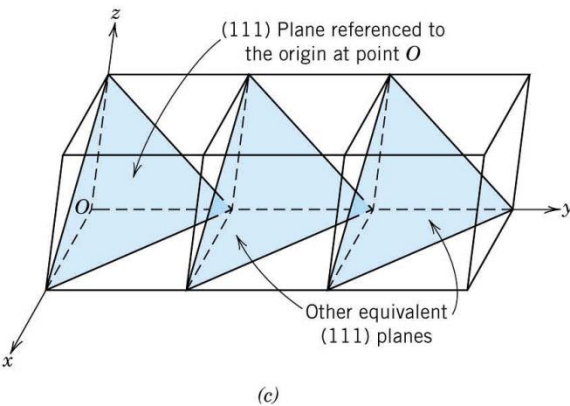
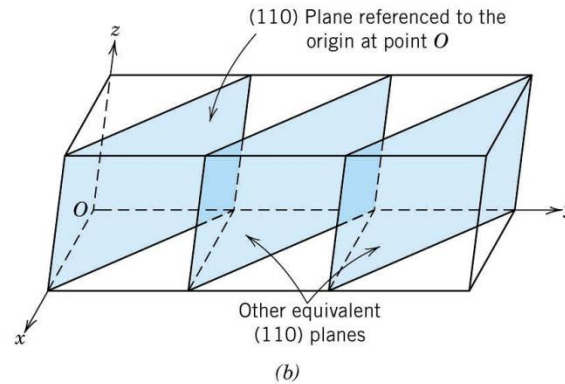
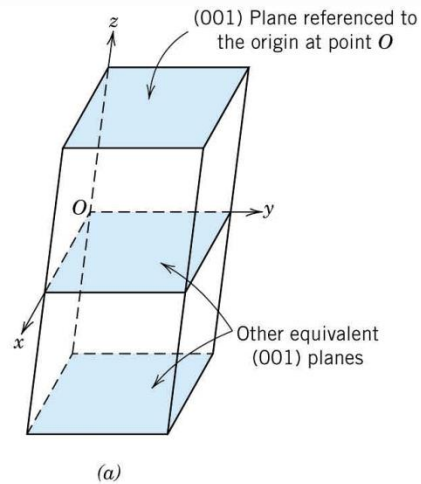

Crystallographic Planes

Problem: Determine the Miller indices for the plane

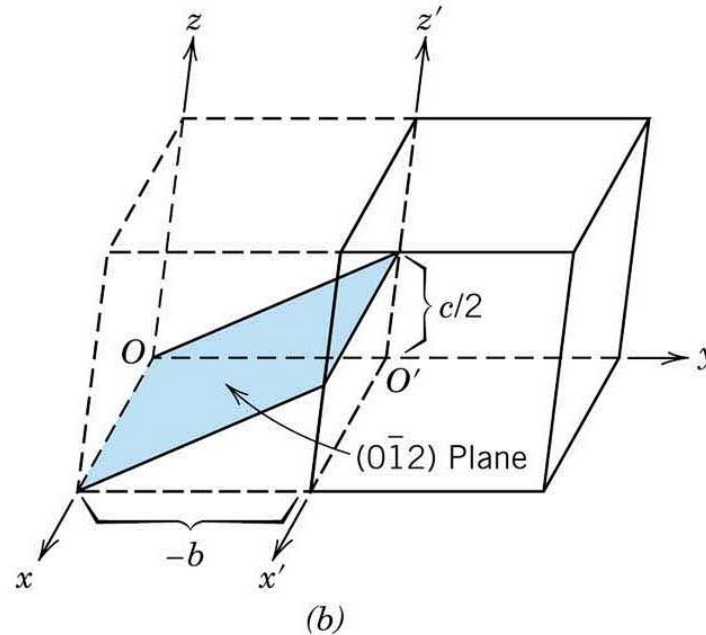
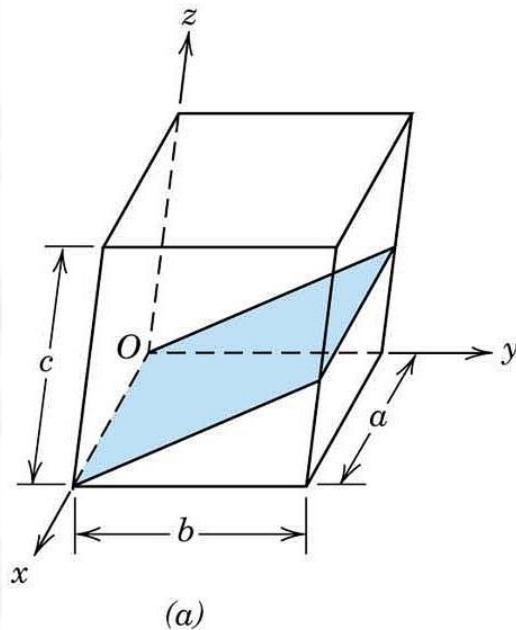

Solution:

1. Since the plane passes through the existing origin the **new origin must be selected** at the corner of adjust unit cell.
2. As related to new origin the following **intercepts** (in terms of lattice parameters a , b , and c) with x , y , z axes can be referred: ∞ (plane is // to x -axis), -1 , $1/2$
3. The **reciprocal** of these numbers are: 0 , -1 and 2 and they **are already integer!**
4. Thus the Miller indices of the consider plane are: $(0\bar{1}2)$

Crystallographic Calculations

There are typical crystallographic calculations that are performed in real space, reciprocal space, or using both spaces, depending on the calculation target.

Real Space

In this space we operate with crystallographic directions. Typically, we need to calculate the angle between crystallographic directions, $[u\ v\ w]$ and $[u^*\ v^*\ w^*]$, within a certain crystal. By using full expressions of these vectors, namely, $\mathbf{r} = u\mathbf{a}_1 + v\mathbf{a}_2 + w\mathbf{a}_3$ and $\mathbf{r}^* = u^*\mathbf{a}_1 + v^*\mathbf{a}_2 + w^*\mathbf{a}_3$, we find:

$$\cos\varphi = \frac{\mathbf{r} \cdot \mathbf{r}^*}{|\mathbf{r}| \cdot |\mathbf{r}^*|} = \frac{(u\mathbf{a}_1 + v\mathbf{a}_2 + w\mathbf{a}_3) \cdot (u^*\mathbf{a}_1 + v^*\mathbf{a}_2 + w^*\mathbf{a}_3)}{\sqrt{(u\mathbf{a}_1 + v\mathbf{a}_2 + w\mathbf{a}_3) \cdot (u\mathbf{a}_1 + v\mathbf{a}_2 + w\mathbf{a}_3)} \sqrt{(u^*\mathbf{a}_1 + v^*\mathbf{a}_2 + w^*\mathbf{a}_3) \cdot (u^*\mathbf{a}_1 + v^*\mathbf{a}_2 + w^*\mathbf{a}_3)}}$$

Note that the result of calculations *also* depends on the relationship between vectors $\mathbf{a}_1, \mathbf{a}_2, \mathbf{a}_3$.

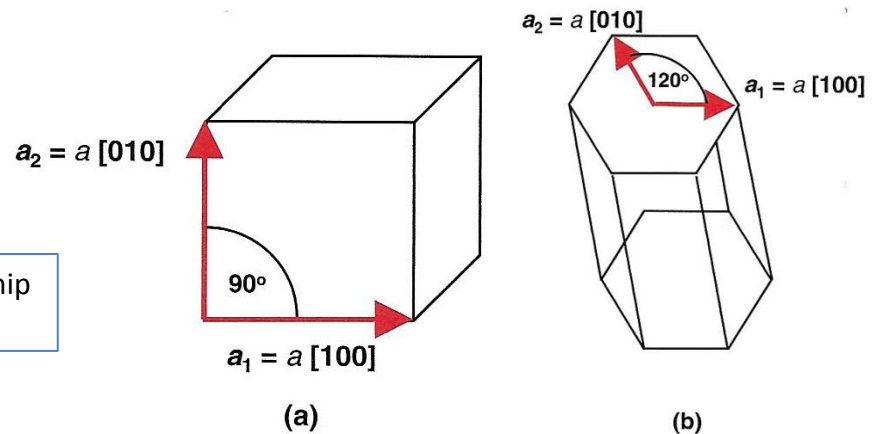

Angles between two crystallographic directions

Real Space

The angle between two crystallographic directions:

$$\cos \varphi = \frac{\mathbf{r} \cdot \mathbf{r}^*}{|\mathbf{r}| \cdot |\mathbf{r}^*|} = \frac{(ua_1 + va_2 + wa_3)(u^*a_1 + v^*a_2 + w^*a_3)}{\sqrt{(ua_1 + va_2 + wa_3)(ua_1 + va_2 + wa_3)} \sqrt{(u^*a_1 + v^*a_2 + w^*a_3)(u^*a_1 + v^*a_2 + w^*a_3)}} \quad (\text{A})$$

Two vectors are **mutually perpendicular** when:

$$(ua_1 + va_2 + wa_3)(u^*a_1 + v^*a_2 + w^*a_3) = 0$$

If all angles **between translation vectors** are 90° equation (A) transforms to :

$$\cos \varphi = \frac{uu^*a^2 + vv^*b^2 + ww^*c^2}{\sqrt{(ua)^2 + (vb)^2 + (wc)^2} \sqrt{(u^*a)^2 + (v^*b)^2 + (w^*c)^2}}$$

where $|\mathbf{a}_1| = a$, $|\mathbf{a}_2| = b$, $|\mathbf{a}_3| = c$.

Two **crystallographic directions** are perpendicular:

$$uu^*a^2 + vv^*b^2 + ww^*c^2 = 0$$

Note that the result of calculations **also** depends on the relationship between vectors $\mathbf{a}_1, \mathbf{a}_2, \mathbf{a}_3$.

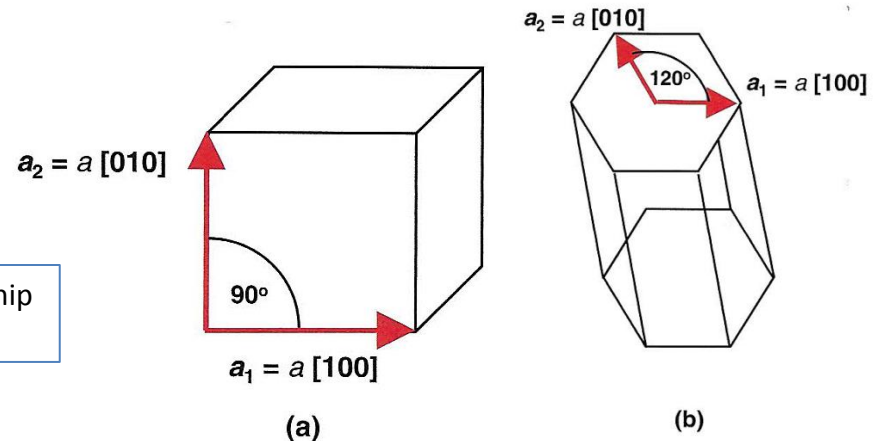

The bond-length calculation

Real Space

Another example of calculations in real space provides the bond-length calculation. The bond length, L , is measured between two atoms, occupying positions (x_1, y_1, z_1) and (x_2, y_2, z_2) . Correspondingly:

$$L = \sqrt{[(x_2 - x_1)\mathbf{a}_1 + (y_2 - y_1)\mathbf{a}_2 + (z_2 - z_1)\mathbf{a}_3] \cdot [(x_2 - x_1)\mathbf{a}_1 + (y_2 - y_1)\mathbf{a}_2 + (z_2 - z_1)\mathbf{a}_3]} \quad (\text{B})$$

Note again that the result of calculations *also* depends on the relationship between vectors $\mathbf{a}_1, \mathbf{a}_2, \mathbf{a}_3$.

If all angles **between all translation vectors** are 90° equation (B) transforms to :

$$L = \sqrt{(x_2 - x_1)^2 a^2 + (y_2 - y_1)^2 b^2 + (z_2 - z_1)^2 c^2}$$

where again $|\mathbf{a}_1| = a$, $|\mathbf{a}_2| = b$, $|\mathbf{a}_3| = c$.

As an example, let us find the shortest C–O bond in calcite (CaCO_3) structure. This bond is within the planar carbonate group (CO_3), having the following atomic coordinates: C – $(0, 0, 0)$, O – $(x, 0, 0)$, $(0, x, 0)$, $(x, x, 0)$ (with $x = 0.257$)

Relevant translations have equal lengths, $|\mathbf{a}_1| = |\mathbf{a}_2| = a = 4.990 \text{ \AA}$, and angle between them $\gamma = 120^\circ$.

Putting this numbers to Equation (B) gives $L_{\text{C-O}} = x \cdot a = 1.282 \text{ \AA}$

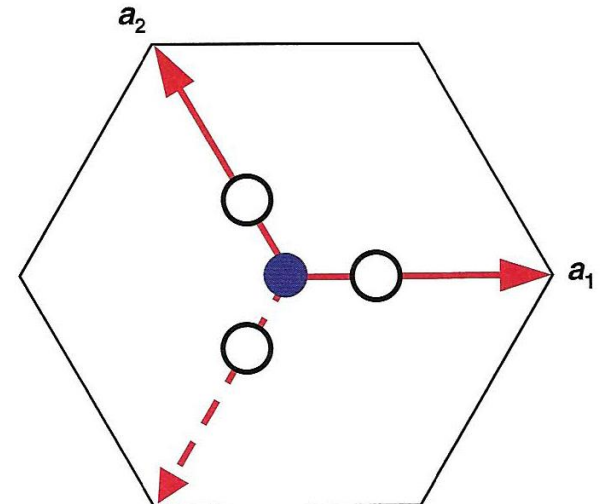

Atomic arrangement within planar carbonate group CO_3 in calcite: C – filled circle; O – open circles. Translation vectors, \mathbf{a}_1 and \mathbf{a}_2 , are indicated by arrows.

The bond-length calculation : Examples

Real Space

If all angles between all translation vectors are 90° equation (B) transforms to Equation (C) :

$$L = \sqrt{(x_2 - x_1)^2 a^2 + (y_2 - y_1)^2 b^2 + (z_2 - z_1)^2 c^2}$$

where again $|a_1| = a$, $|a_2| = b$, $|a_3| = c$.

Interesting information can be extracted from comparison between the C–C bond lengths in two carbon-comprising structures: diamond and graphite. Diamond has cubic structure with carbon atoms occupying the cube vertices and the centers of the cube faces. The rest of the atoms are located in positions shifted from those mentioned by one quarter along one of the space cube diagonals (see Figure 1.10). It follows from Figure 1.10 that the shortest bond is between atoms with coordinates (0, 0, 0) and (1/4, 1/4, 1/4). Since the structure is a cubic one, we use Equation (C) for bond-length calculation. Substituting into Equation (C) atomic coordinates and lattice parameter of diamond $a = b = c = 3.567 \text{ \AA}$, we find $L_{C-C} = 1.545 \text{ \AA}$.

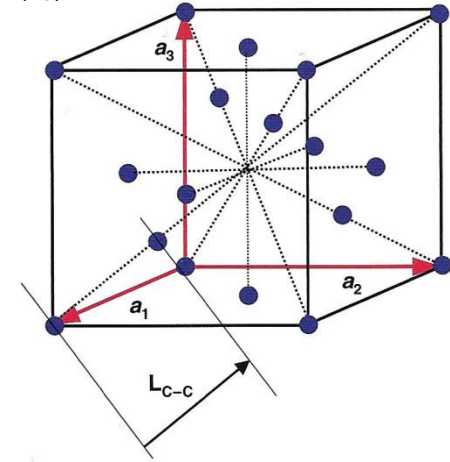

By contrast, graphite has so-called hexagonal structure with lattice parameters $|a_1| = |a_2| = a = 2.456 \text{ \AA}$ and $|a_3| = c = 6.694 \text{ \AA}$. The angle between translations a_1 and a_2 is 120°, other angles equal 90° (see Figure 1.11). Atoms within the unit cell occupy the following positions (0, 0, 0); (0, 0, 1/2); (1/3, 2/3, 0); (2/3, 1/3, 1/2). It follows from Figure 1.11 that graphite has layered structure along the a_3 -axis with interlayer spacing $L^*_{C-C} = c/2 = 3.347 \text{ \AA}$, which is much larger than the length, L_{C-C} , of the shortest C–C bond within individual layer. In order to calculate the L_{C-C} -value, we put into Equation (B) coordinates of neighboring atoms (000) and (1/3, 2/3, 0) within the layer, as well as the lattice parameters mentioned, which yields $L_{C-C} = a/\sqrt{3} = 1.418 \text{ \AA}$.

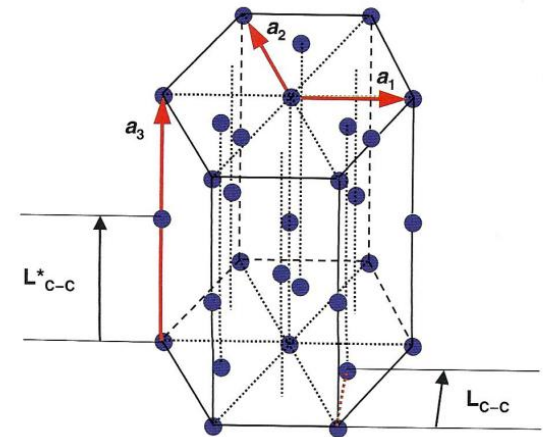

Crystallographic Calculations

Reciprocal Space

Here, we operate with crystallographic planes. Typically, we have to calculate the angle between crystallographic planes (hkl) and $(h^*k^*l^*)$ within the same structure:

$$\mathbf{H} = h\mathbf{b}_1 + k\mathbf{b}_2 + l\mathbf{b}_3 \quad \text{and} \quad \mathbf{H}^* = h^*\mathbf{b}_1 + k^*\mathbf{b}_2 + l^*\mathbf{b}_3.$$

we find:

$$\begin{aligned} \cos \varphi &= \frac{\mathbf{H} \cdot \mathbf{H}^*}{|\mathbf{H}| \cdot |\mathbf{H}^*|} = \\ &= \frac{(h\mathbf{b}_1 + k\mathbf{b}_2 + l\mathbf{b}_3) \cdot (h^*\mathbf{b}_1 + k^*\mathbf{b}_2 + l^*\mathbf{b}_3)}{\sqrt{(h\mathbf{b}_1 + k\mathbf{b}_2 + l\mathbf{b}_3) \cdot (h\mathbf{b}_1 + k\mathbf{b}_2 + l\mathbf{b}_3)} \sqrt{(h^*\mathbf{b}_1 + k^*\mathbf{b}_2 + l^*\mathbf{b}_3) \cdot (h^*\mathbf{b}_1 + k^*\mathbf{b}_2 + l^*\mathbf{b}_3)}} \end{aligned}$$

Note again that the result of calculations *also* depends on the relationship between vectors $\mathbf{b}_1, \mathbf{b}_2, \mathbf{b}_3$.

Two planes are perpendicular when:

$$(h\mathbf{b}_1 + k\mathbf{b}_2 + l\mathbf{b}_3) \cdot (h^*\mathbf{b}_1 + k^*\mathbf{b}_2 + l^*\mathbf{b}_3) = 0$$

Again if all angles **between vectors in reciprocal space** are 90° equations can be simplified:

$$\cos \varphi = \frac{(hh^*/a^2) + (kk^*/b^2) + ll^*/c^2}{\sqrt{(h/a)^2 + (k/b)^2 + (l/c)^2} \sqrt{(h^*/a)^2 + (k^*/b)^2 + (l^*/c)^2}} \quad (hh^*/a^2) + (kk^*/b^2) + (ll^*/c^2) = 0$$

The orthogonality condition for crystallographic planes has its simplest form in cubic crystals ($a = b = c$):

$$hh^* + kk^* + ll^* = 0$$

Angle between Crystallographic Planes

Reciprocal Space

$$\cos \varphi = \frac{(hh^*/a^2) + (kk^*/b^2) + ll^*/c^2}{\sqrt{(h/a)^2 + (k/b)^2 + (l/c)^2} \sqrt{(h^*/a)^2 + (k^*/b)^2 + (l^*/c)^2}} \quad (\text{A})$$

The orthogonality condition for crystallographic planes has its simplest form in cubic crystals ($a = b = c$):

$$hh^* + kk^* + ll^* = 0 \quad (\text{B})$$

For example, by using Equation (B) we immediately find the triads of mutually perpendicular planes in cubic crystals, as for example, (100), (010), and (001); or (110), (1-10), and (001); or (111), (1-10), and (11-2), normals to which could be used as Cartesian coordinate axes. At the same time, applying Equation (A) to the (130) and (-110) planes in the aragonite structure ($a = 4.962 \text{ \AA}$, $b = 7.969 \text{ \AA}$, $c = 5.743 \text{ \AA}$), shown in Figure , we find

$$\cos \varphi = \frac{1 - (b^2/3a^2)}{\sqrt{(1 + (b/a)^2)(1 + (b/3a)^2)}}$$

- C
- Ca
- ▲ O1
- ◆ O2

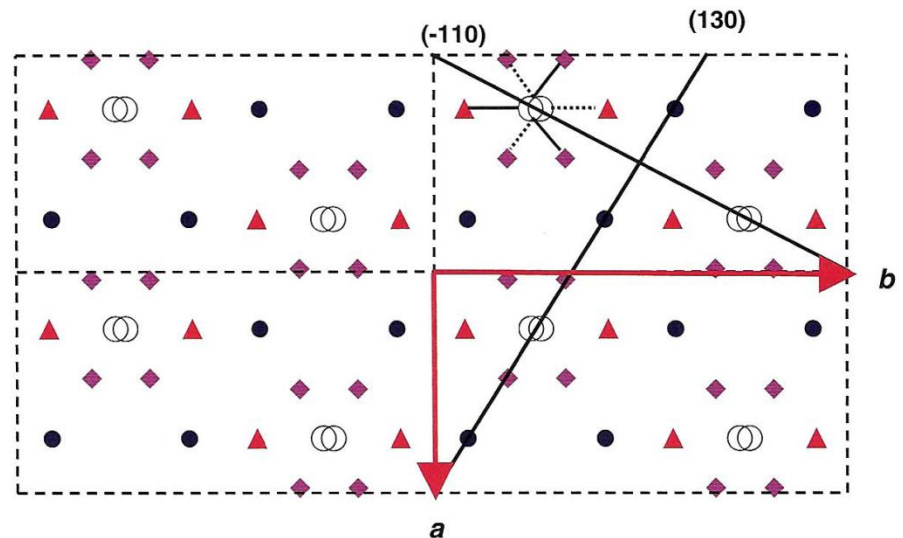

D-spacing

Reciprocal Space

In reciprocal space, we also calculate the length of vector H , which is related to the d -spacing between planes (hkl) :

$$|H| = \frac{1}{d} = \sqrt{(hb_1 + kb_2 + lb_3)(hb_1 + kb_2 + lb_3)}$$

Applying the equation to cubic crystal yields:

$$d^{-1} = \frac{\sqrt{h^2 + k^2 + l^2}}{a}$$

Applying the equation to tetragonal crystal yields:

$$d^{-1} = \sqrt{\frac{h^2 + k^2}{a^2} + \frac{l^2}{c^2}}$$

Applying the equation for hexagonal crystal yields:

$$d^{-1} = \sqrt{\frac{4}{3} \cdot \left(\frac{h^2 + hk + k^2}{a^2}\right) + \frac{l^2}{c^2}}$$

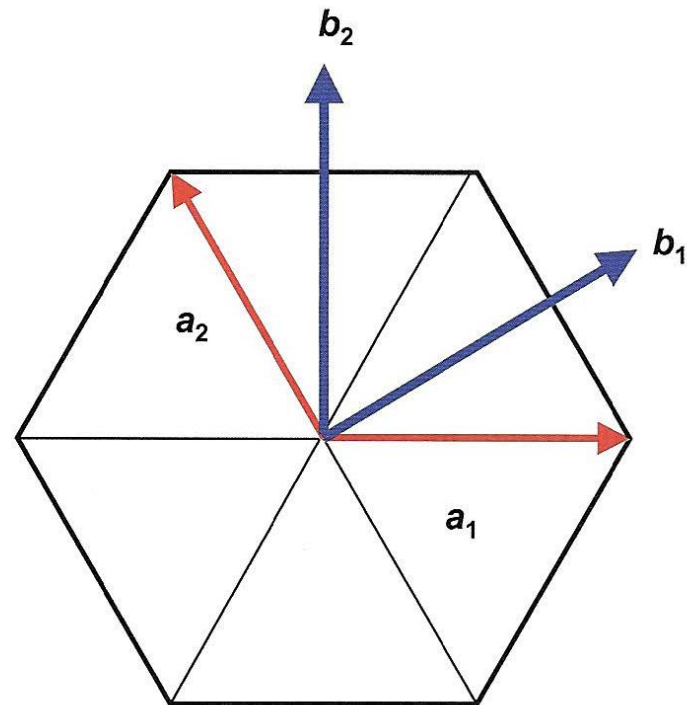

Angle between crystallographic direction & plane

Both Space

Some calculations require usage of both spaces, the real and reciprocal ones. This is the case when calculating an angle between crystallographic direction, $r [u, v, w]$, and plane $H (hkl)$:

$$\begin{aligned}\cos \varphi &= \frac{\mathbf{r} \cdot \mathbf{H}}{|\mathbf{r}| \cdot |\mathbf{H}|} = \frac{(ua_1 + va_2 + wa_3)(hb_1 + kb_2 + lb_3)}{|\mathbf{r}| \cdot |\mathbf{H}|} \\ &= \frac{uh + vk + wl}{\sqrt{(ua_1 + va_2 + wa_3)(ua_1 + va_2 + wa_3)} \sqrt{(hb_1 + kb_2 + lb_3)(hb_1 + kb_2 + lb_3)}}\end{aligned}$$

If vector r and H having the same indices are parallel or not?

- In cubic crystals all vectors with identical indices are parallel since there are no difference between real and reciprocal space. In fact setting $u=h, v=k, w=l$ in above equation together with $|a_1| = a, |b_1| = 1/a, \alpha = \beta = \gamma = 90^\circ$, yields .

$$\cos \varphi = \frac{h^2 + k^2 + l^2}{a\sqrt{h^2 + k^2 + l^2} \cdot (1/a)\sqrt{h^2 + k^2 + l^2}} = 1 \text{ and } \varphi = 0.$$

However, any symmetry reduction results in a finite angle between certain vectors $r [hkl]$ and $H (hkl)$, which thus are no longer parallel. For example, in tetragonal crystals ($|a_1| = |a_2| = a, |a_3| = c, |b_1| = |b_2| = 1/a, |b_3| = 1/c$, and $\alpha = \beta = \gamma = 90^\circ$) this angle equals:

$$\cos \varphi = \frac{h^2 + k^2 + l^2}{\sqrt{h^2 + k^2 + (c/a)^2 l^2} \cdot \sqrt{h^2 + k^2 + (a/c)^2 l^2}}.$$

We see again that those vectors r and H that are sensitive to the tetragonality of the unit cell, that is, have both projections h, k and l , are nonparallel ($\varphi \neq 0$).