

1. Consider the sliding block problem discussed in class and depicted below. In this problem we will look at the *tangential* or drag force:

a. Using the scaling approach employed in class, show how the viscous drag on the block depends on the various parameters of the problem to within an unknown function of $(d_2-d_1)/d_1$.

b. Determine an integral relationship for the dimensionless drag force in terms of the velocity and pressure gradients (Hint: the drag is just the integral of the shear stress evaluated at the surface of the plate, or the shear stress plus a pressure contribution term evaluated at the surface of the block. The difference arises from the angle the block makes with the x-axis).

c. Using the solution for the pressure given in class, numerically integrate the expression in (b) to get the dimensionless drag, and plot it up as a function of $(d_2-d_1)/d_1$. It should go to one for $(d_2-d_1)/d_1 = 0$.

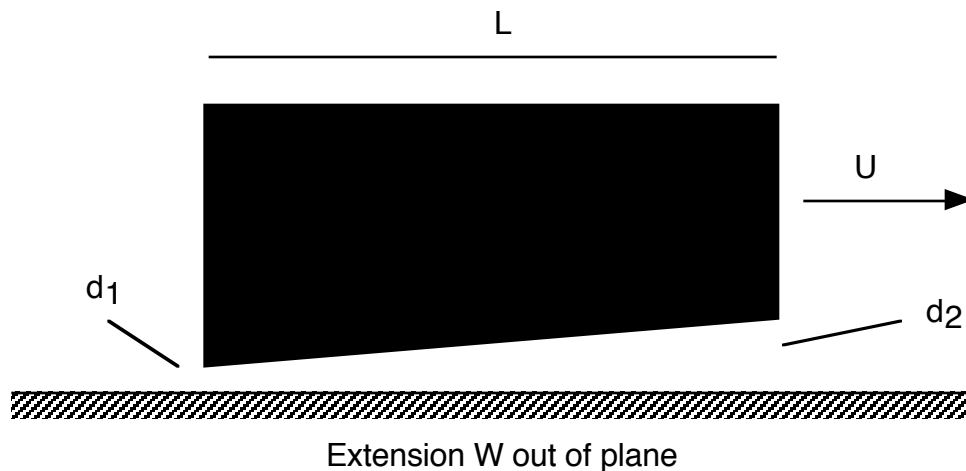

2. For a sliding block of dimensions $L = 10\text{cm}$, $W = 30\text{cm}$, and $d_2-d_1 = 0.1\text{cm}$ (e.g., a fixed inclination angle), determine the velocity U at which the block can support a weight of 100kg while maintaining a minimum separation $d_1 = 0.01\text{cm}$. Take the fluid viscosity to be 0.5 poise.

3. Flow inside a collapsing 45° wedge. Consider the flow depicted below. If we can ignore the inertial terms ($Re \ll 1$), the flow is governed by the Biharmonic Equation. The velocity at $\theta = 0$ is zero, while that at $\theta = \theta_0 = \pi/4$ is $u_r = 0$, $u_\theta = -\Omega r$ where Ω is the angular velocity of the upper plate.

- Using the trial function employed for the wiper problem discussed in class, solve for the streamfunction.
- Using the matlab contour command, plot up the streamlines.

Hint: The streamfunction will be of the form $\psi = 0.5 \Omega r^2 f(\theta)$.

Second Hint: The four homogeneous solutions for $f(\theta)$ are 1 , θ , $\sin(2\theta)$, and $\cos(2\theta)$.

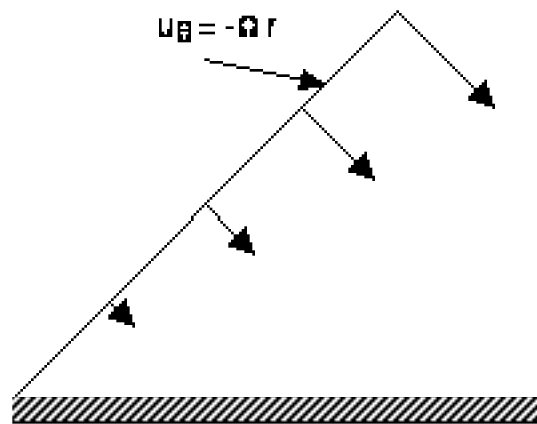

4. Dimensional Analysis: Modeling air entrainment in a draining tank. Consider the liquid tanker rail car depicted below. If the tank contains a viscous fluid (e.g., Karo syrup - that's what's in all those "ADM" tankers you see at the railroad crossings around here) then we know that as the tank drains a vortex will form and eventually air will be entrained into the drainpipe - something we want to avoid. We want to determine the allowable operating conditions for our large tank by studying the behavior of a model system (geometrically similar), but employing a less viscous fluid. If the model tank is a 1:20 scale model, and the viscosity of the Karo syrup is 30p (density $=1.4\text{ g/cm}^3$), what should be the properties of the fluid used in the model system? How does the draw off rate scale between the model and full size tanker?

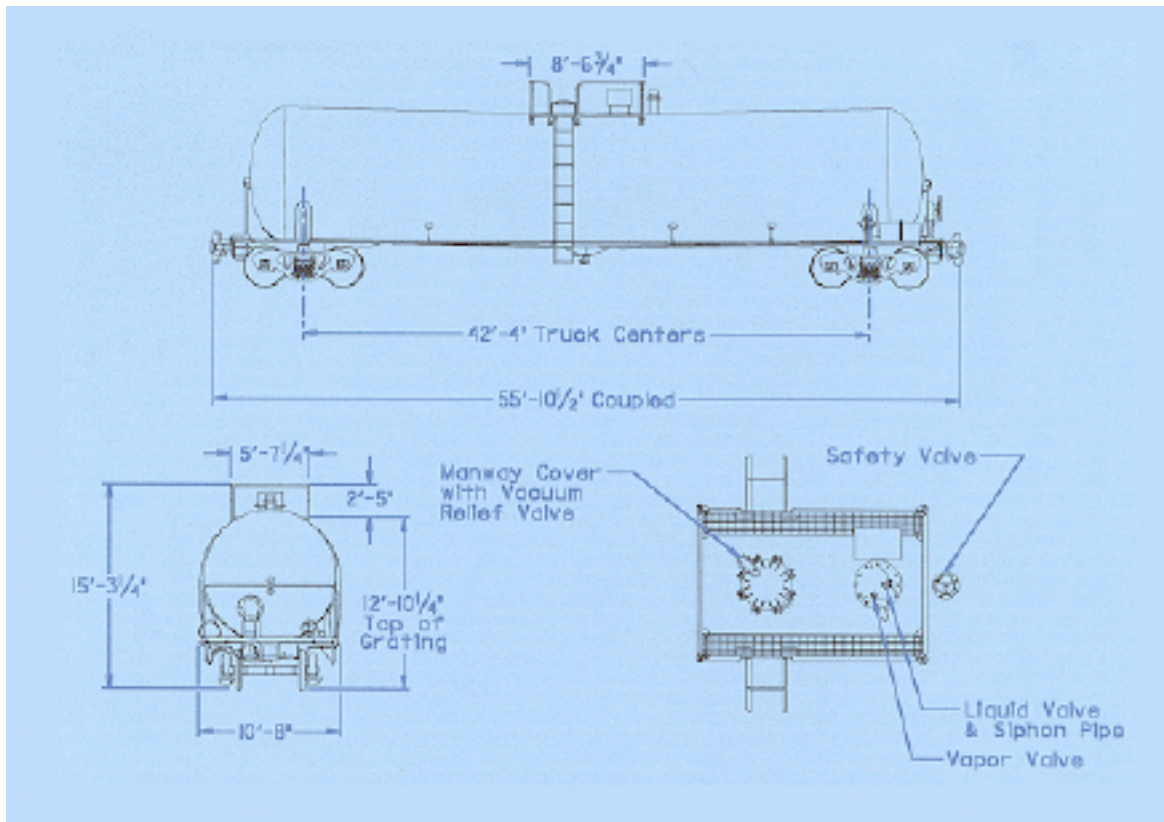

5. Thermodynamics and Scaling Analysis: In this problem we estimate the temperature and fluid velocity in a chimney as a function of various physical parameters. The chimney is of cross-sectional area A and height H , thus the total volume of air in the chimney is AH . We have a source of energy at the bottom given by Q (assumed to be distributed over the whole area). The energy, of course, raises the temperature of the air, causing it to expand. Using the principles of conservation of energy and momentum, and neglecting all frictional and heat losses, estimate the velocity and temperature of the air in the chimney. Hint: You are going to have to remember some of your Thermodynamics from last term to get this one!