

1. In order to improve understanding of the disaster, it is proposed to simulate the Great Molasses Flood by building a scale model of the collapsing tank and surrounding buildings using colored water rather than molasses. If the kinematic viscosity of the molasses is 44 centistokes, what should be the dimensions of the model tank, and by what factor will the velocity in the model system be reduced?

2. Consider the parallel plate viscometer depicted below. The viscometer consists of two parallel disks of radius R separated by a gap h . In operation, the gap between the disks is filled with a viscous fluid and the lower plate is rotated with some angular velocity Ω , resulting in some torque on the upper plate. The gap width is quite small ($h/R \ll 1$), so the fluid is confined to the space between the plates by surface tension. The ratio of the torque to the angular velocity is proportional to the fluid viscosity (at least for Newtonian fluids).

a. If we may neglect the non-linear inertia terms (i.e., low Reynolds number flow), show that the equations of motion are satisfied by a velocity $u_\theta = f(r, z)$ with $u_r, u_z = 0$. Determine the velocity profile and calculate the torque on the upper plate as a function of the experimental parameters.

b. By examining the equations of motion in the r and z directions, demonstrate that the above solution will not satisfy the full Navier-Stokes equations. Identify which terms give rise to difficulties and provide a short physical explanation for what is occurring. Sketch the velocity profile you expect to see in the r - z plane (Don't try to solve for this secondary current velocity profile unless you like alot of extra work).

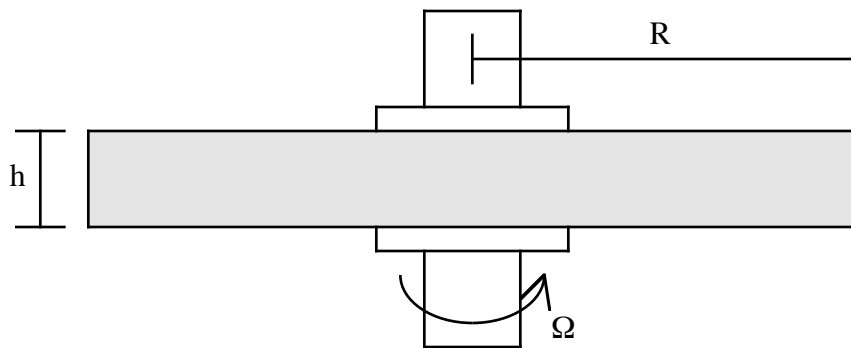

3. A common problem in determining the rheological behavior of suspensions of particles in viscous fluids is measuring the viscosity of the suspensions in a parallel plate viscometer. This presents difficulties, however, if the particle density is somewhat greater than the fluid density since the particles would tend to settle, affecting the observed viscosity. As a budding rheologist, you are asked to estimate the magnitude of this effect. So:

- A suspension containing a volume fraction ϕ_0 of solid particles has been placed in the parallel plate device depicted above. The particles tend to settle, however, so that after some time a clear fluid layer ($\phi = 0$) of thickness h_1 forms between the top of the

suspension and the upper plate, and a settled layer ($\phi = \phi_{\max}$) forms at the bottom. If the suspension in between remains at concentration ϕ_0 , determine the thickness of the settled layer and of the remaining suspension.

- The viscosity of a concentrated suspension of uniform spheres is given approximately by:

$$\mu = \mu_0 \left[\exp(-2.34 \phi) / (1 - \phi / \phi_{\max})^3 \right]$$

where μ_0 is the viscosity of the pure fluid and $\phi_{\max} = .62$. Using the principle that the shear stress and velocity profiles are continuous functions of position, determine the velocity profile in each of the three regions and determine the torque exerted on the upper plate. Compare this torque to that obtained if the entire gap were filled with a suspension of concentration ϕ_0 . If $\phi_0 = .45$ and $h_1/h = .1$, what is the reduction in the observed torque?

4. A viscosity pump is depicted below. Fluid is pumped from inlet A to outlet B by the rotating drum of radius R . Note that $p_A < p_B$, and that this pressure gradient will induce some backflow from B to A. The gap width h is considered to be much less than R , so that the flow in the gap may be modelled as flow between parallel planes. Neglecting all inertial effects, calculate the flow rate per unit width of this pump Q/W (it is assumed to extend out of the paper a distance W) as a function of Ω , $p_B - p_A$, R , and h . What is the maximum Δp it can pump against? Calculate the resulting torque on the shaft which drives the drum and the mechanical energy input to the system. If the useful work done on the fluid is given by $Q \cdot \Delta p$, what is the energy efficiency of the pump? Where does the extra energy go?

