

1. Scaling Of The Transport Equations: Energy transport is analogous to momentum transport and the equation governing energy transport may be scaled in the same way as the momentum equations were in class. Consider flow past the flat plate  $y=0$  as depicted below. Fluid with a dimensionless temperature  $T = 0$  flows along the plane in the  $x$  direction with velocity  $u = Gy$  where  $G$  is the shear rate (e.g., plane Couette flow without the upper plane). The plate is maintained at a temperature  $T = 0$  for  $x < 0$  and a temperature  $T = 1$  for  $x > 0$ . The governing equations and boundary equations are given below.

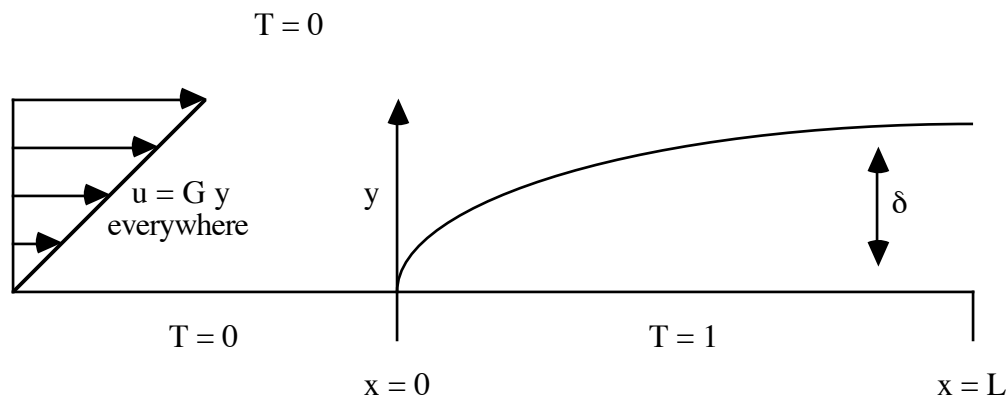

$$G y \frac{\partial T}{\partial x} = \alpha \left( \frac{\partial^2 T}{\partial x^2} + \frac{\partial^2 T}{\partial y^2} \right)$$

$$T \Big|_{y=0, x < 0} = 0 \qquad T \Big|_{y \gg 0} = 0 \qquad T \Big|_{y=0, x > 0} = 1$$

a). Using  $L$  as the characteristic length in the  $x$  direction and  $\delta$  the length in the  $y$  direction, render the energy transport equations dimensionless. For what value of  $\delta$  is convection (the left hand side) balanced by a diffusive term (in the right hand side). Using this scaling, what dimensionless parameter must be small to neglect one of the two diffusion terms (the dimensionless parameter should no longer involve  $\delta$ )? Doing this, obtain the simplified thermal boundary layer equation for this problem.

b). The total rate of energy loss from the region of the plate  $0 < x < L$  is given below. Using inspectional analysis on the boundary layer equation, determine the increase in  $Q$  if  $L$  is doubled.

$$Q = \int_0^L -k \frac{\partial T}{\partial y} dx$$

2. In this problem we formulate the boundary layer equations from the standpoint of vorticity. Recall that vorticity is defined as:

$$\omega = \nabla \times \mathbf{u}$$

For an incompressible fluid ( $\nabla \cdot \mathbf{u} = 0$ ) the equation of vorticity for steady 2-D flow is given by:

$$\omega = \frac{\partial v}{\partial x} - \frac{\partial u}{\partial y}$$

$$\frac{\partial u}{\partial x} + \frac{\partial v}{\partial y} = 0$$

$$u \frac{\partial \omega}{\partial x} + v \frac{\partial \omega}{\partial y} = \nu \left( \frac{\partial^2 \omega}{\partial x^2} + \frac{\partial^2 \omega}{\partial y^2} \right)$$

where  $\tilde{\omega} = \omega \hat{e}_z$

By a development analogous to that done in class, scale the equation of vorticity, the defining relation for vorticity, and the equation of continuity to obtain the boundary layer equations governing the vorticity distribution for a flat plate of length  $L$  in uniform flow (note that for 2-D flows the only component of vorticity that is non-zero is that normal to the plane of flow, thus  $\omega$  may be represented by a scalar times the unit vector in that direction as is given above). What is the characteristic magnitude of  $\omega$  in the boundary layer?

3. Creeping Flow / Index Notation: At low Reynolds numbers the force on an object is directly proportional to the velocity of an object. Here we look at the drag on a rectangular prism as a function of its direction of motion (relative to its orientation, which is kept fixed).

a. Write down the most general relation for the force  $F_i$  as a function of the velocity  $U_j$  (Hint: this will involve an unknown second order tensor).

b. Experimentally, the unknown tensor could be determined by looking at the drag on the cube when it is moving face on in each of the three principle directions. This could also be done numerically - with a really big computer! By symmetry, the force can only be in the direction of motion, if the object is moving face on. Assuming you have the results from such a study, determine the general *resistance tensor* in terms of the resistance ( $F/U$ ) for motion in each of the three directions. You should be able to show that the resistance tensor is purely diagonal for a rectangular prism aligned with the principle axes as depicted below. (note that you can get the general result for arbitrary orientation of the prism just by rotating the coordinate axes - a messy but fairly straightforward procedure)

c. Finally, using the results of part b, prove that the drag on a cube is isotropic (e.g., it doesn't matter if the cube is moving point on, face on, or edge on).

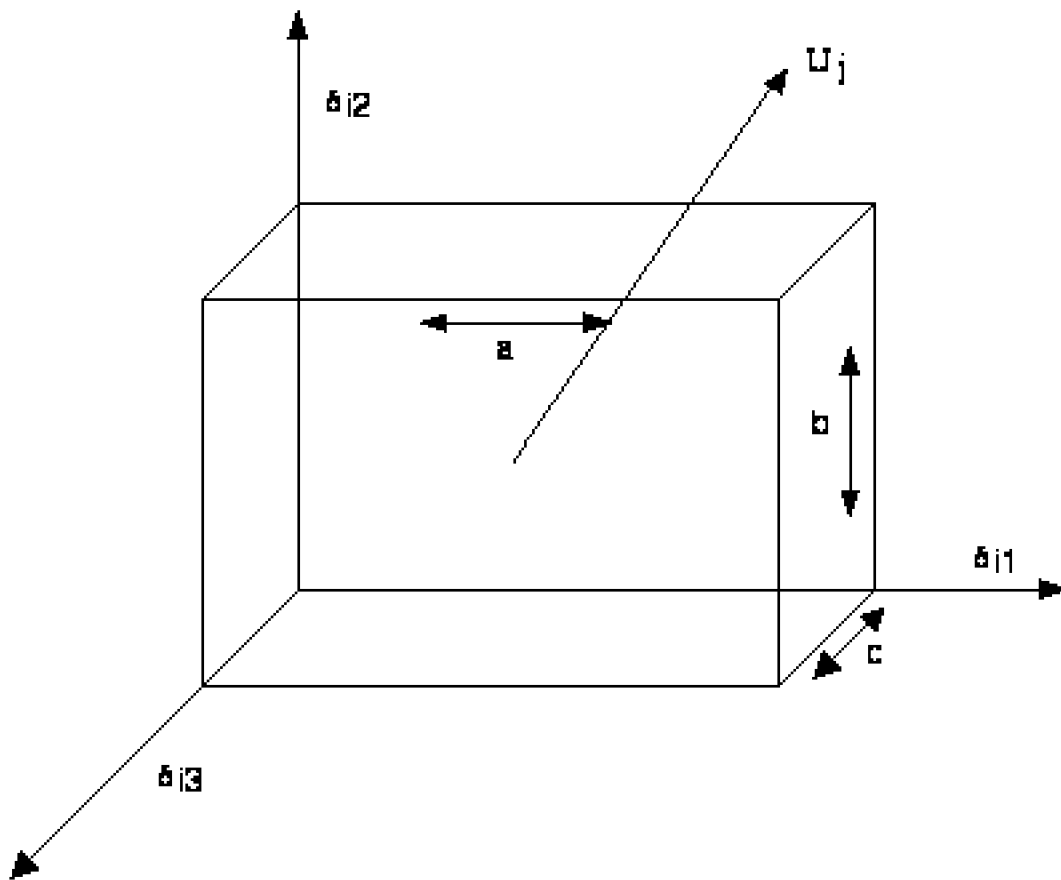

4. Using the minimum dissipation theorem, estimate the drag on a tetrahedron with edge length  $s$  under creeping flow conditions. Although it's alot messier to do than the problem given above, it's possible to show that the drag on this shape (or any regular polyhedron with sufficient symmetry is isotropic as well - but it's going to be alot messier! I'll leave that part as a homework problem for the graduate students next semester...