

1). Consider the geometry below. Two sheets are drawn with a velocity U between two rollers of radius R whose surfaces are separated by a distance $2b_0$. The idea is to fill the space between the sheets with a viscous fluid of viscosity μ , and all the action takes place in a lubrication layer between the rollers, at least in the limit $b_0/R \ll 1$. Here we analyze this problem.

a. By scaling the flow equations in the gap (use Cartesian coordinates!), show how the force/width on the rollers F/L scales with the separation distance between the rollers and the other parameters of the problem.

b. The sheet sandwich detaches from the rollers downstream at a point x_d and final gap width $2b_f > 2b_0$ when the pressure again returns to zero. Develop an implicit integral relation for the ratio b_f/b_0 , and show that it doesn't depend on any of the other parameters of the problem.

c. Develop an integral relationship for the dimensionless pressure and force and evaluate it numerically.

Hint: the gap geometry in the lubrication limit is given by $b = b_0 + \frac{1}{2} \frac{x^2}{R}$ where x is the distance along the gap from the point of minimum separation. By continuity, the flow rate per extension into the paper (Q/W) through any vertical plane -must- be the same, and must equal the exit flow rate $U \cdot 2b_f$.

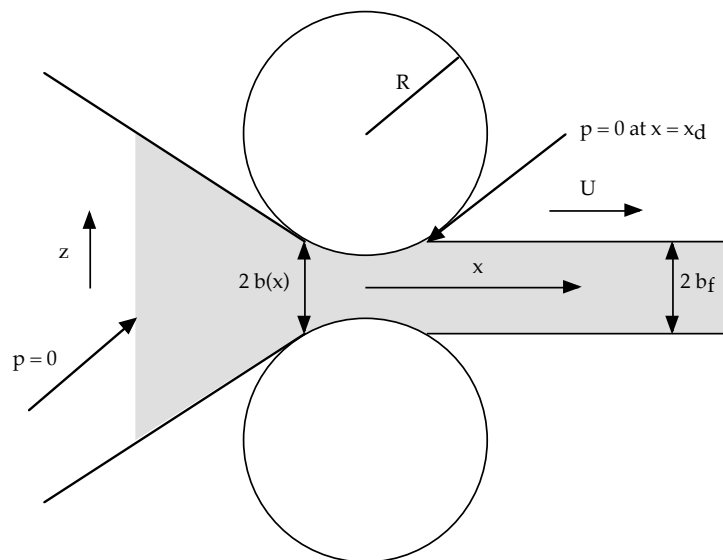

2. For the sliding block considered in class with dimensions $L = 10\text{cm}$, $W = 30\text{cm}$, and $d_2 - d_1 = 0.1\text{cm}$ (e.g., a fixed inclination angle), determine the velocity U at which the block can support a weight of 100kg while maintaining a minimum separation $d_1 = 0.01\text{cm}$. Take the fluid viscosity to be 0.5 poise.

3. Dimensional Analysis: Modeling air entrainment in a draining tank. Consider the liquid tanker rail car depicted below. If the tank contains a viscous fluid (e.g., Karo syrup - that's what's in all those "ADM" tankers you see at the railroad crossings around here) then we know that as the tank drains a vortex will form and eventually air will be entrained into the drainpipe - something we want to avoid. We want to determine the allowable operating conditions for our large tank by studying the behavior of a model system (geometrically similar), but employing a less viscous fluid. If the model tank is a 1:20 scale model, and the viscosity of the Karo syrup is 30p (density = 1.4 g/cm^3), what should be the properties of the fluid used in the model system? How does the draw off rate scale between the model and full size tanker?

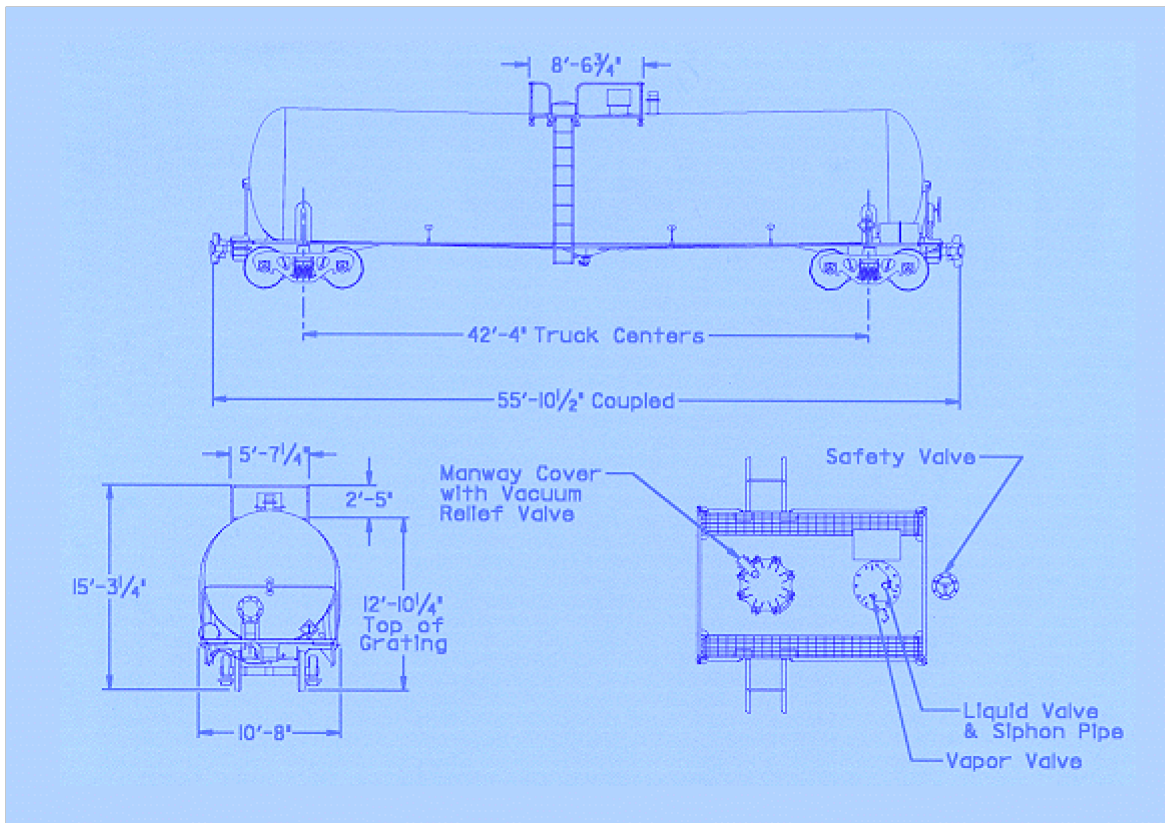

4. Thermodynamics and Scaling Analysis: In this problem we estimate the temperature and fluid velocity in a chimney as a function of various physical parameters. The chimney is of cross-sectional area A and height H , thus the total volume of air in the chimney is AH . We have a source of energy at the bottom given by Q (assumed to be distributed over the whole area). The energy, of course, raises the temperature of the air, causing it to expand. Using the principles of conservation of energy and momentum, and neglecting all frictional and heat losses, estimate the velocity and temperature of the air in the chimney. Hint: You are going to have to remember some of your Thermodynamics from last term to get this one!