

1. Mixing two fluids of different density in a very large tank can be quite challenging: the denser fluid tends to stay on the bottom, and it is hard to get it to mix in. You are in charge of developing a scale model to simulate a mixer for the Hanford cleanup problem. The full-scale system has a tank that is 10m high, and the two fluids to be mixed have a density of 1.4 g/cm^3 and 1.1 g/cm^3 , and a viscosity of 6 cp and 2 cp, respectively. You have constructed a 1:8 scale model to test mixing strategies.

a. If you were to preserve strict dynamic similarity, what should be the densities and viscosities of the fluids in the model system, and what should be the scaling factor for the velocities between the model and full-scale systems?

b. You discover that there simply isn't any reasonable way to satisfy the conditions in (a), thus you go to the concept of approximate dynamic similarity. What fluids and scaling factors should you use in this case?

c. For the conditions determined in (b), how would the mixing times scale between the two systems?

2. Consider the parallel plate viscometer depicted below. The viscometer consists of two parallel disks of radius R separated by a gap h . In operation, the gap between the disks is filled with a viscous fluid and the lower plate is rotated with some angular velocity Ω , resulting in some torque on the upper plate. The gap width is quite small ($h/R \ll 1$), so the fluid is confined to the space between the plates by surface tension. The ratio of the torque to the angular velocity is proportional to the fluid viscosity (at least for Newtonian fluids).

a. If we may neglect the non-linear inertia terms (i.e., low Reynolds number flow), show that the equations of motion are satisfied by a velocity $u_\theta = f(r,z)$ with $u_r, u_z = 0$. Determine the velocity profile and calculate the torque on the upper plate as a function of the experimental parameters.

b. By examining the equations of motion in the r and z directions, demonstrate that the above solution will not satisfy the full Navier-Stokes equations. Identify which terms give rise to difficulties and provide a short physical explanation for what is occurring. Sketch the velocity profile you expect to see in the r - z plane (Don't try to solve for this secondary current velocity profile unless you like a lot of extra work). In our lab we actually use this secondary current for all sorts of experiments.

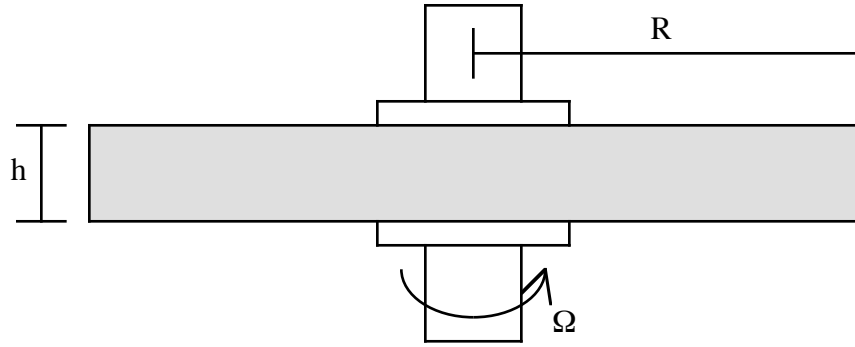

3. A common problem in determining the rheological behavior of suspensions of particles in viscous fluids is measuring the viscosity of the suspensions in a parallel plate viscometer. This presents difficulties, however, if the particle density is somewhat greater than the fluid density since the particles would tend to settle, affecting the observed viscosity. As a budding rheologist, you are asked to estimate the magnitude of this effect. So:

a. A suspension containing a volume fraction ϕ_0 of solid particles has been placed in the parallel plate device depicted above. The particles tend to settle, however, so that after some time a clear fluid layer ($\phi = 0$) of thickness h_0 forms between the top of the suspension and the upper plate, and a settled layer ($\phi = \phi_{\max}$) forms at the bottom. If the suspension in between remains at concentration ϕ_0 , determine the thickness of the settled layer and of the remaining suspension via a mass (or volume) balance.

b. What is the maximum value h_0/h can take on as a function of ϕ_0 ?

c. The viscosity of a concentrated suspension of uniform spheres is given approximately by:

$$\mu = \mu_0 \left[\exp(-2.34 \phi) / (1 - \phi / \phi_{\max})^3 \right]$$

where μ_0 is the viscosity of the pure fluid and $\phi_{\max} = .62$. Using the principle that the shear stress and velocity profiles are continuous functions of position, determine the velocity profile in each of the three regions and determine the torque exerted on the upper plate. What is the ratio of this torque to that obtained if the entire gap were filled with a suspension of concentration ϕ_0 ?

d. Using your favorite computer language (Matlab is highly recommended here!) graphically display this torque ratio over the allowable range of h_0/h for five values of ϕ_0 in the range $0 < \phi_0 < \phi_{\max}$.

4. A viscosity pump is depicted below. Fluid is pumped from inlet A to outlet B by the rotating drum of radius R . Note that $p_A < p_B$, and that this pressure gradient will induce some backflow from B to A. The gap width h is considered to be much less than R , so that the flow in the gap may be modeled as flow between parallel planes.

a. Neglecting all inertial effects, calculate the flow rate per unit width of this pump Q/W (it is assumed to extend out of the paper a distance W) as a function of Ω , $p_B - p_A$, R , and h .

b. What is the maximum Δp it can pump against?

c. Calculate the resulting torque on the shaft that drives the drum and the mechanical energy input to the system. If the useful work done on the fluid is given by $Q \cdot \Delta p$, what is the energy efficiency of the pump? Where does the extra energy go?

