

①

CBE 30355 Transport I

This semester we will study fluid mechanics: the motion of fluids (and solids) in response to applied forces such as shear or pressure or body forces ranging from gravity to electrokinetic or magnetic forces

We will use conservation principles to derive mathematical descriptions of simple & complex phenomena. Such mathematical models can be used to understand and predict phenomena and solve engineering problems!

2

Admin Details

Because of the pandemic, I will provide narrated video recordings of each lecture as well as posting the notes online. These videos (and notes) should be reviewed prior to our in class session, which will be devoted to Q/A & demos. A short on-line quiz for each lecture will be due no later than $\frac{1}{2}$ hr after the class, and the cumulative quiz score will count the same as an exam.

We will have weekly homework to be turned in on-line (scan).

3

In addition to the quizzes, we will have a mid-term and a final (in-class).

There will be a TA for the course (TBA) and likely an UG tutor.

My office hours will be via Zoom by arrangement, or 4-5 PM M-F

Honor Code: Exams (and quizzes) should be individual works. You may work together on HW, however you may not use HW solutions from previous years!

(4)

OK, why should we care about fluids??

⇒ Vital to the world around us!

- What causes a hurricane & determines its path? A tornado?

- How do you design a sprinkler system so that all areas are doused equally in case of fire?

- How can you design an artificial heart so that it pumps blood without tearing up blood cells?

- How can you mix fluids in a chip-based HTS system

5

All these questions are answered by applying fundamental conservation laws as well as material properties to complex systems!

What is conserved?

- Mass (neither created nor destroyed)
- Momentum ($F = ma$)
- Energy (we'll get there eventually...)

We will apply these conservation laws to fluids, but they apply equally well to solids (or anything in between!)

What is a fluid?

⑥

fluid vs. solid

fluid: exhibits continuous deformation

⇒ doesn't snap back after stress is removed!

(thermodynamics: the state of mat'l depends on rate of shear!)

Solids: Elastic deformation -

like a rubber band, snaps back after stress is removed!

(thermo & state depends on total deformation)

Virtually everything lies between these two states!

Examples: metal creep, elastic polymer fluid

Properties of Fluids

(7)

If we characterize fluids by rate of deformation, most important prop. relates to resistance to deformation \Rightarrow viscosity!

We have a thought exp^t:
put mat'l in a gap between plates:

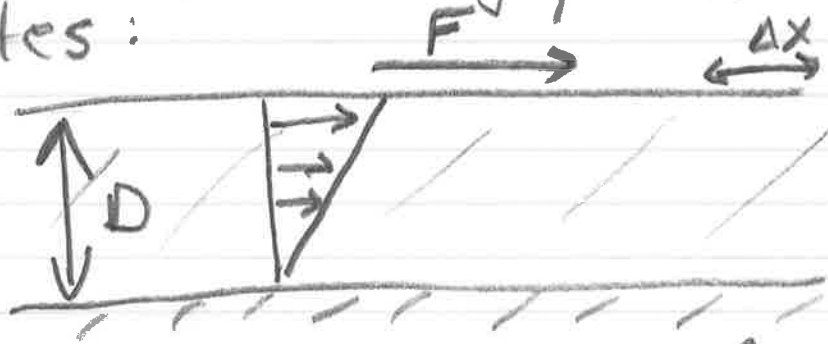

If mat'l is elastic solid, we get some fixed displacement Δx for a given force F at S.S.

If linearly elastic, relation is linear.

$$\frac{F}{A} = \frac{\Delta X}{D} E$$

- displacement (8)

← Young's Modulus of Elasticity

↳ force/area ↳ gap

What are units of E ? \Rightarrow same as F/A ! Usually given as psi, dyne/cm², etc!

What units to use?? - depends on application, but you should know all of them! \Rightarrow know how to convert! I usually use cgs - most approp. for low Re flow (specialty). McCreech would use MKS - high Re. Old systems in English units \Rightarrow all are the same physics!

OK, we fill it with a fluid ^⑨
What happens? \Rightarrow will get
continuous deformation!

Plate will move w/ some velocity

$$U = \frac{\Delta(x)}{\Delta t}$$

For a Newtonian fluid

$$\frac{F}{A} = \frac{U}{D} \mu \leftarrow \text{viscosity!}$$

$\hookrightarrow \frac{g}{cm \cdot s}$ (poise)

"poise" is short for Poiseuille,
name assoc. w/ pipe flow.

$\frac{U}{D}$ is rate of strain \Rightarrow
known as shear rate

Velocity field is known as
plane Couette flow, simple shear flow

10

You should get to know the jargon!

What are the viscosities of some simple fluids?

Water $\approx 1 \text{ cP}$ (centipoise, 10^{-2} poise)

Karo Syrup $\approx 30 \text{ P}$ (temp. dep.)

Air $\approx 0.02 \text{ cP}$

All these are Newtonian fluids!

What are ex. of non-Newtonian fluids?

\Rightarrow One feature is stress-strain relation is not linear (or may not be)

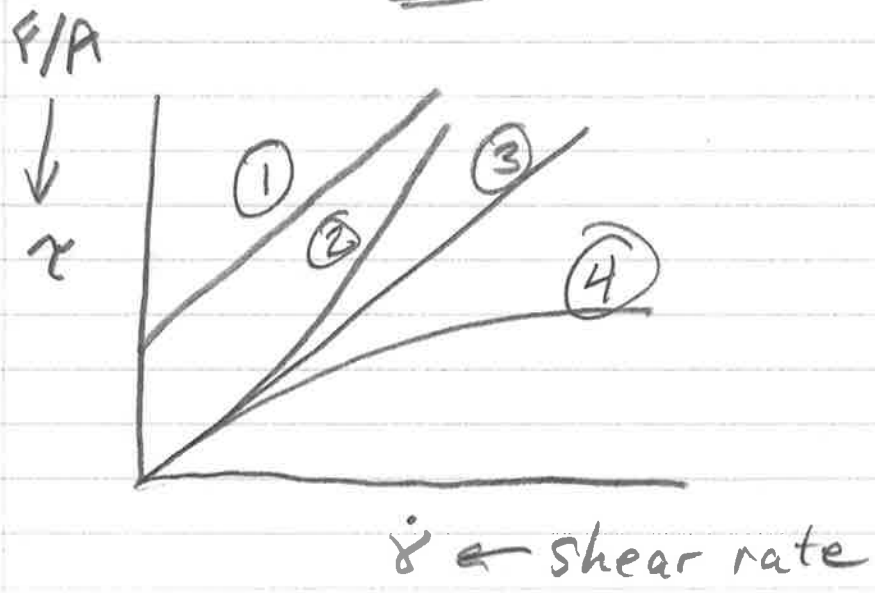

(11)

① Bingham plastic \Rightarrow a linear relation betw. τ & $\dot{\gamma}$, but there is a yield stress \Rightarrow no motion until critical strain exceeded!

Ex: frozen OJ, Mayo

② Dilatant $\Rightarrow \mu$ increases w/ $\dot{\gamma}$
Not seen as often - some clay suspensions do this (armor)

③ Newtonian

④ Pseudoplastic $\Rightarrow \mu$ decreases w/ $\dot{\gamma}$
Also called shear thinning - very common in polymer melts!

May be much more complicated than this! μ may be time dep., may

(12)

exhibit combination of phen.

Example: liquid chocolate - exhibits yield stress & shear thinning! Imp. if fabricating chocolate figurines!

Other examples: cytological fluid:

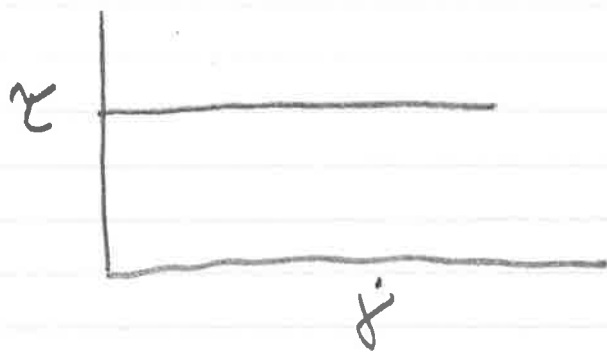

indeterminate shear rate for applied shear stress! Leads to complex patterns in cytological streaming!

Normal stresses $\Rightarrow \mu$ may not be a scalar! \Rightarrow If you shear fluid one way, may get stress in a different direction! Arises in fluids w/ structure.

13

Suspensions \Rightarrow area of research at ND. Example - wet sand - if you step on it, it dries out!

Study of stress-strain relationship is rheology

2nd property: Density

\Rightarrow we are interested in transport

of momentum which is velocity \times mass

\therefore density is important!

Density of water = 1 g/cm^3

a.r = $1.2 \times 10^{-3} \text{ g/cm}^3$

Hg = 13.6 g/cm^3

Actually, we are interested in

Momentum diffusivity ν (14)

(better known as kinematic viscosity)

$$\nu \equiv \frac{\mu}{\rho} \text{ - units } \frac{L^2}{T}$$

in cgs $1 \frac{cm^2}{s} = 1 \text{ stokes}$

(name associated w/ flow eqns)

Units of ν same as molecular
diff. D_{AB} , thermal diff. $\alpha \Rightarrow$
governs rate w/ which mom.

diffuses

material	ν
water	1 cs
air	15 cs
Hg	0.5 cs
Karo Syrup	25 <u>stokes</u>

what do these numbers ⁽¹⁵⁾ mean?

Determine time to approach steady-state!

Thought exp't \Rightarrow take metal poker, stick one end in fire - eventually, your hand gets fried!
How long? Controlled by diffusivity

Remember: $[\alpha] \equiv \frac{L^2}{T}$

Thus $T \sim \frac{L^2}{\alpha}$

for a metal, $\alpha \sim 0.11 \text{ cm}^2/\text{s}$ (steel)

Thus if poker is 2 ft long (60 cm) it takes 0 (10) hr for your end to get hot! Actually, more complicated as loses heat to air all along shaft

What about fluids? Look at ⁽¹⁶⁾
diffⁿ of momentum \Rightarrow same
thought exp^t:

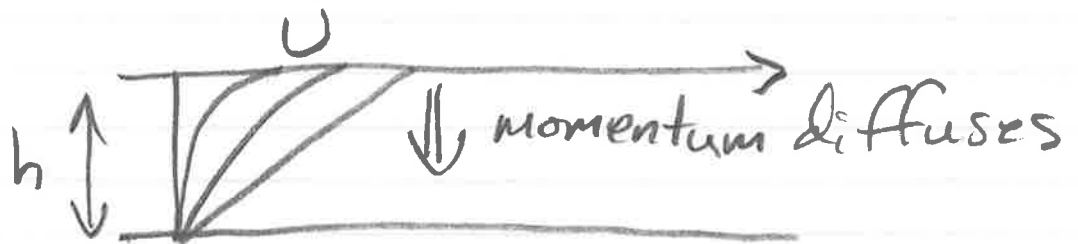

How long till lower plate feels
motion?

$$T \sim \frac{h^2}{\nu}$$

If $h = 1 \text{ cm}$

$$T = \mathcal{O}(100 \text{ s}) \text{ in water}$$

$$= \mathcal{O}(200 \text{ s}) \text{ in Hg}$$

$$= \mathcal{O}(0.04 \text{ s}) \text{ in Karo syrup!}$$

Actually, this is only order of magnitude!
 \Rightarrow solⁿ of transient problem shows $\sim 4x$
faster than these values.

(17)

Other Properties:

Speed of sound V_s - important
in jet aircraft, high speed
machinery

Related to compressibility of fluid:
Sound is a pressure wave travelling
thru a fluid

$$V_s = \left(\frac{\partial P}{\partial \rho} \right)_T^{1/2}$$

For an ideal gas $P = \frac{\rho}{M} RT$

$$\text{Thus } \left(\frac{\partial P}{\partial \rho} \right)_T = \frac{RT}{M} = \frac{(8.3 \times 10^7 \frac{\text{erg}}{\text{mol}^\circ\text{K}})(300^\circ\text{K})}{(29 \text{ g/mol})}$$

$$= 8.6 \times 10^8 \text{ cm}^2/\text{s}^2$$

$$\text{Thus } V_s = 2.9 \times 10^4 \text{ cm/s}$$

$$= 655 \text{ mph}$$

18

When $U/V_s \sim 1$ flow is compressible
 \Rightarrow this means that fluid density
is affected by fluid motion.

Importance gauged by Mach #

$$M = U/V_s$$

For liquids $(\frac{\partial \rho}{\partial P})_T$ is very large
& U is usually smaller, so flow
can be regarded as incompressible.

Surface Tension: usually denoted
by σ (sometimes γ)

$\sigma \Rightarrow$ energy required to create
interfacial surface area

$$\text{Units} = \frac{\text{erg}}{\text{cm}^2}$$

This causes bubbles to be spheres!
(minimize surface/volume)

(19)

Result is a "tension" along the surface \rightarrow higher pressure within concave side of bubble like inside of a balloon!

$$\Delta P \sim \frac{\sigma}{R} \quad (\text{inverse to radius})$$

Surfactants (soap) are a material that likes both fluids, thus reduces σ

Coefficient of thermal expansion:

$$\beta = -\frac{1}{S} \left(\frac{\partial S}{\partial T} \right)_P = \frac{1}{V} \left(\frac{\partial V}{\partial T} \right)_P = \frac{1}{T}$$

for an ideal gas.

Important in natural convection problems, such as draft off window - will look at this in Sr. Lab.

(20)

OK, what types of flows are there?

Compressible vs. Incomp.

- depends on $M = U/V_s$

- even in air, most flows are incompressible! Usually study compressible flows in Aero E.

Laminar vs. Turbulent

- Flow is laminar if layers of fluid slip smoothly over each other

- Laminar flow may be steady (unchanging in time) or unsteady

⇒ look at flow from tap. At low flows, looks like a glassy, steady stream.

(21)
What happens if we increase
flow rate? \Rightarrow becomes rough,
unsteady \rightarrow transition to turbulence.

Turbulence is chaotic, time dep
& very difficult to describe
mathematically w/ precision - still,
it occurs most of the time!

Both laminar & turbulent flow
may occur in the same geometry
 \Rightarrow famous exp't in pipe flow by
Osbourne Reynolds. Found transition
from laminar to turbulent flow governed
by dimensionless parameter Re :

$$Re = \frac{\text{inertial forces}}{\text{viscous forces}} = \frac{UD}{\nu} \approx 2100$$

we'll look at this in detail later!

Continuum Hypothesis

we want to develop a mathematical descr. of fluid flow: this requires taking fluid to be a continuum.

Is this continuum hypothesis reasonable? => sometimes!

=> fluid is made up of molecules bouncing into each other. In a gas phase, molecules may go sig. dist. before hitting each other! Not a continuum on this length scale!

Suppose we have probe of orb. size - what would it see??

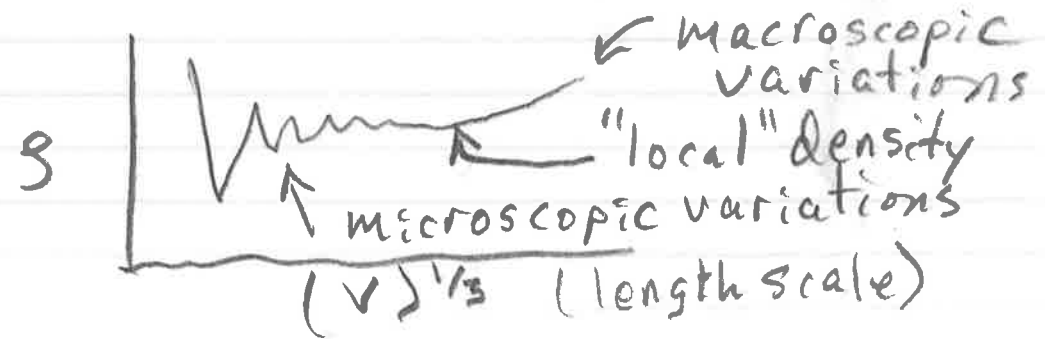

23

We would take value between
"microscopic variation" length scale
and "macroscopic variation" scale
to be "local" density \Rightarrow same
for "local" velocity, pressure, temp,
etc! This may not work!

\Rightarrow minimum length for continuum
hyp. to hold is mean free path
length — distance molecule travels
before hitting another. In

a gas
$$\lambda \sim \frac{1}{\sqrt{2} \pi d^2 n}$$

where d is molecule dia. & n
is number density (molecules/vol)

At 70 mi, $\lambda \sim 10$ cm, so will
affect flow in boundary layer of
a rocket, for ex.

At 1 atm & room temp, we have λ is just a few \AA . For liquids it's even smaller!

Non-continuum effects are imp. even in liquids, though \Rightarrow the most imp. ex. is Brownian motion
 \rightarrow In a liquid small particles are kicked around by molecules, thus they execute a random walk - gives rise to diffusion - usually imp. for particles 1 μm or less in dia.

We will assume continuum hyp. to apply, also leads to no-slip condition \Rightarrow at a solid surface in contact w/ fluid, velocity is continuous!

(25)
Fluid layer adjacent to solid surface moves w/ velocity of surface

If $\lambda > \lambda$ (char length of flow), may not be in contact, so would get a "slip" condition - modifies aerodynamics of returning shuttle, or flow in a vacuum pump.

Also get breakdown of continuum hyp. in composite media (susp) - not valid on length scales of order particle size. \Rightarrow leads to wall slip as well, makes working with suspensions tricky!

When we will describe motion, ρ , μ , etc. at a "point", really mean some avg over a volume large w.r.t. λ or molecule (particle) size!

Forces on a Fluid Element ⁽²⁶⁾

We need to apply $F = ma$ to a fluid \Rightarrow what are the forces?

Consider an arbitrary element:

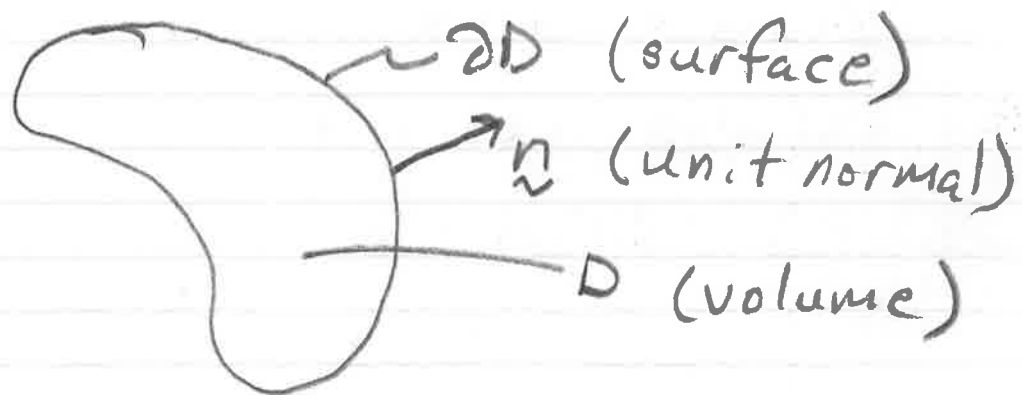

What are the forces on the molecules in D ? Divide into Surface Forces and Body Forces!

What is a body force? \Rightarrow They act on each molecule in D .

Examples:

Gravity: $\vec{F} = \rho g \Delta V$

↳ force on a differential volume!

Electric Field:

$\vec{F} = \vec{E} \rho \Delta V$

↑ charge/volume
electric field (volt/cm)

⇒ this force is critical in electro-osmosis & electrophoresis. we use this effect to separate proteins in our laboratory!

Magnetic field:

$\vec{F} = \vec{J} \times \vec{B}$ ← magnetic field
↑ current

⇒ Important in plasma dynamics (fusion reactors), field of MHD

OK, what about surface forces?

We divide these into shear forces and normal forces

⇒ Surface forces act on the surface of ∂D

⇒ shear forces act tangential to ∂D ! The F/A in simple shear flow is a shear force!

⇒ normal forces act normal to the surface

Let the F/A of surface force be \underline{f} - a vector. We resolve into tangential & normal

components:

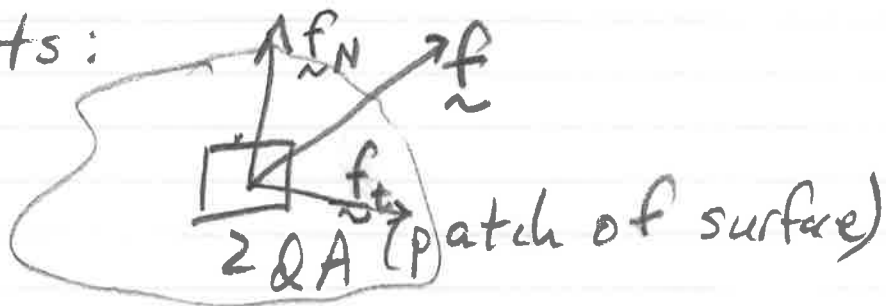

(29)

If the unit normal to a patch of surface ΔA is $\underline{\hat{n}}$

Then $\underline{F}_N = (\underline{f} \cdot \underline{\hat{n}}) \underline{\hat{n}}$

We'll look at \underline{f}_t later, now focus on normal forces!

\Rightarrow Consider an element at rest

If it's at rest, shear forces should be zero. Just have normal forces:

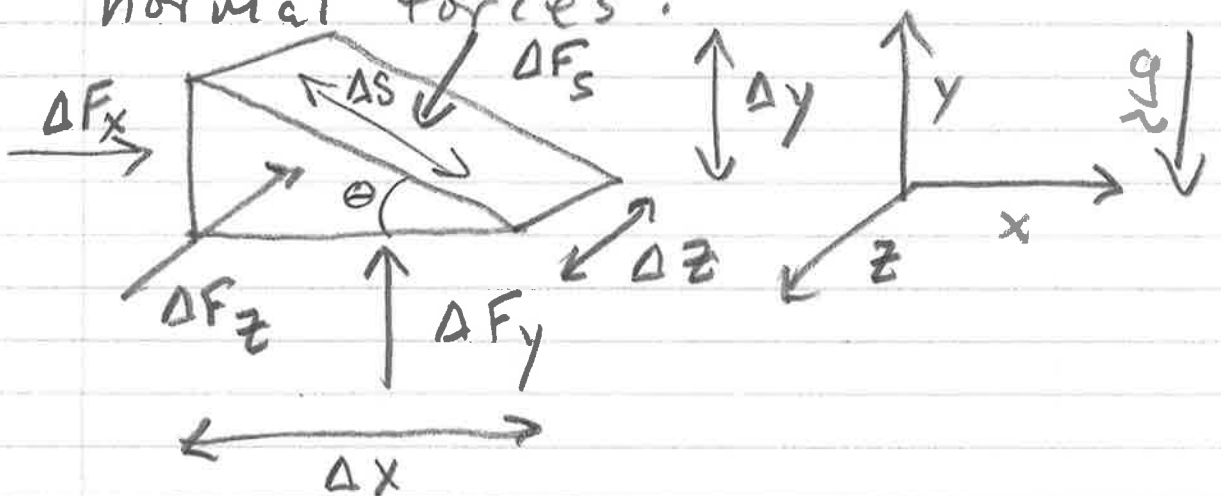

(30)

Let's do a force balance

⇒ Since element is at rest, the net force in each direction must be zero!

The force balance in the x-direction:

$$\sum F_x = \Delta F_x - \Delta F_s \sin \theta = 0$$

↳ component of ΔF_s in x-dir

$$\text{Now } \sin \theta \equiv \frac{\Delta y}{\Delta s}$$

$$\text{Thus } \Delta F_x - \Delta F_s \frac{\Delta y}{\Delta s} = 0$$

or, dividing by $\Delta z \Delta y$:

$$\frac{\Delta F_x}{\Delta z \Delta y} = \frac{\Delta F_s}{\Delta z \Delta s} \leftarrow \begin{array}{l} \text{area of } s \text{ face} \\ \text{area of } x \text{ face} \end{array}$$

Define $\frac{\Delta F_x}{\Delta z \Delta y} = -\sigma_{xx}$ (normal stress)

(31)

Similarly,

$$\frac{\Delta F_s}{\Delta z \Delta S} = -\sigma_{ss}$$

These are normal stresses
They rep. diagonal elements
of the stress tensor!

* Stress tensor \equiv momentum flux

$\sigma_{ij} \equiv$ Force/Area exerted
by fluid of greater i on
fluid of lesser i in j direction!

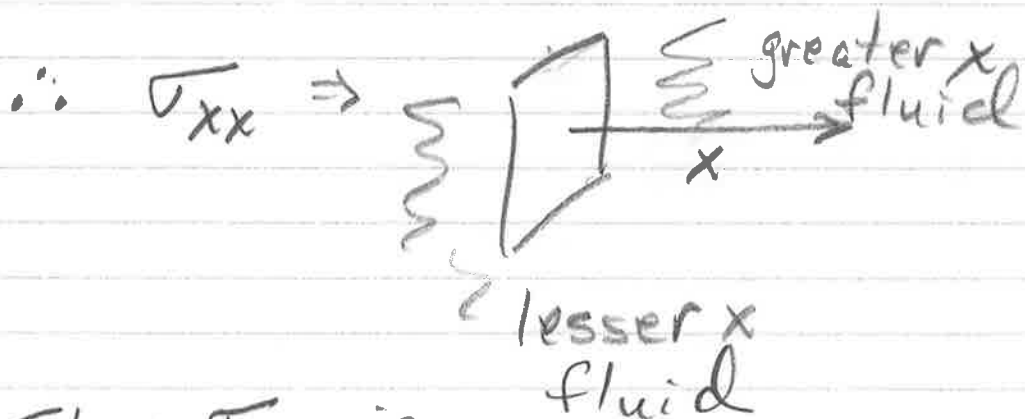

Thus σ_{xx} is
negative in compression.

Note: B S & L defines this 32
backwards (ch 2) \Rightarrow doesn't
 change the physics, just the sign!
 We'll use the conventional (most
 common, anyway) definition in this class!

OK, now look at y -direction:

$$\sum F_y = \Delta F_y - \Delta F_s \cos \theta - \rho g \frac{\Delta x \Delta y \Delta z}{2}$$

$$= \underline{\underline{0}}$$

\nearrow
 weight of fluid!

Recall $\cos \theta = \frac{\Delta x}{\Delta s}$

Thus (dividing thru):

$$\frac{\Delta F_y}{\Delta x \Delta z} - \frac{\Delta F_s}{\Delta s \Delta z} = \frac{\rho g \Delta y}{2}$$

$$\left\{ \begin{array}{l} -\sigma_{yy} \\ -\tau_{ss} \end{array} \right. \quad \text{vanishes as } \Delta y \rightarrow 0!$$

Thus

$$\sigma_{xx} = \sigma_{yy} = \sigma_{zz}$$

* In a fluid at rest, normal stress is isotropic: same in all directions. This normal stress is just \bar{p}
↑
neg sign!

$$p = -\sigma_{xx} = -\sigma_{yy} = -\sigma_{zz}$$

When not at rest, normal stress is, in general, not isotropic!

We define

$$p = -\frac{1}{3} (\sigma_{xx} + \sigma_{yy} + \sigma_{zz})$$

average of the normal stresses!

equiv: $p = -\frac{1}{3} \text{tr}(\underline{\underline{\sigma}})$

↳ trace

How does p vary in a fluid at rest??

Look at a fluid element:

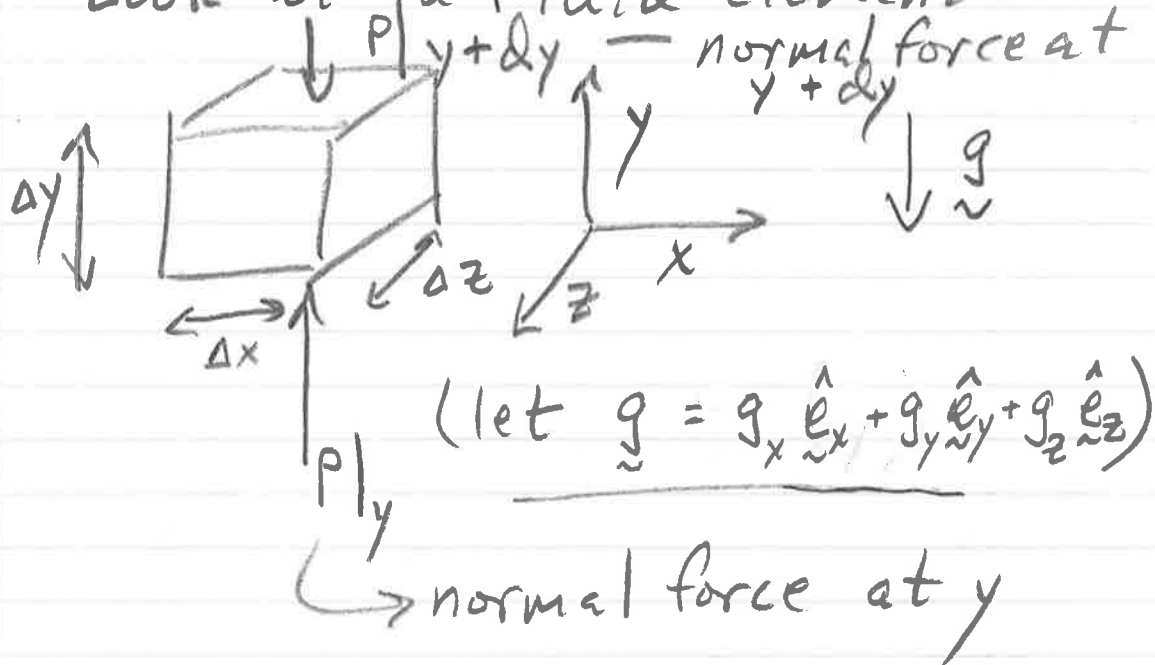

Let's do a force balance in the x -dir:

$$P|_x \Delta y \Delta z - P|_{x+\Delta x} \Delta y \Delta z + \rho g_x \Delta x \Delta y \Delta z = 0$$

Divide through:

$$- \frac{P|_{x+\Delta x} - P|_x}{\Delta x} + \rho g_x = 0$$

Or, in limit $\Delta x \rightarrow 0$:

$$-\frac{\partial P}{\partial x} + \rho g_x = 0$$

Similarly, $\frac{\partial P}{\partial y} = \rho g_y$; $\frac{\partial P}{\partial z} = \rho g_z$

which yield 3 eq'ns!

In vector form:

$$\underline{\nabla} P = \underline{\rho g}$$

Last deriv. was done using shell balances. If you're good at vector notation, there's an easier (better) way!

Consider arbitrary fluid element:



(36)

What are the forces acting on it?

Surface force: $\int_{\partial D} -P \underline{\underline{n}} \, dA$

force on each patch of surface

Body force: $\int_D \rho \underline{\underline{g}} \, dV$

force on each fluid bit

$$\text{So: } \underline{\underline{\sum \underline{F} = 0}}$$

$$\text{Thus } \int_{\partial D} -P \underline{\underline{n}} \, dA + \int_D \rho \underline{\underline{g}} \, dV = \underline{\underline{0}}$$

We now use the Divergence Theorem

$$\int_{\partial D} f \underline{\underline{n}} \, dA \equiv \int_D \underline{\underline{\nabla}} \cdot f \, dV$$

converts surface int. to vol. int!

$$\text{So: } \int_D \{ \nabla P - \rho \underline{\underline{g}} \} QV = 0$$

Now since D was completely arbitrary, it must be true at every point in fluid!

Thus

$$\nabla P - \rho \underline{\underline{g}} = 0$$

$$\text{or } \nabla P = \rho \underline{\underline{g}}$$

It will be a lot easier to derive things this way when we get to fluids in motion!

OK, let's solve some problems

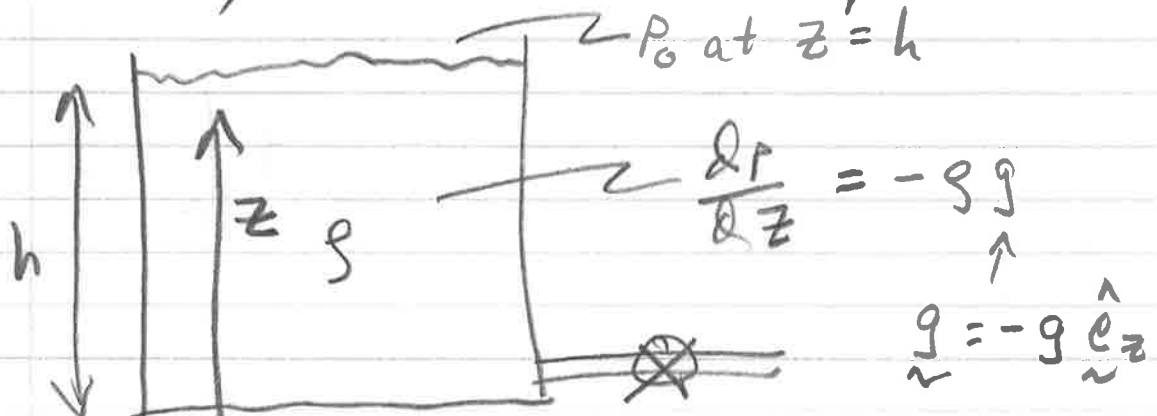

38

Let's Integrate !

$$P = -\rho g z + \text{const}$$

$$P|_{z=h} = P_0$$

$$\text{Thus } P = P_0 + \rho g (h - z)$$

This is just as true in an open body of water (diving):

How deep do you have to go to reach 1 atm gauge (e.g. above the atmospheric pressure)?

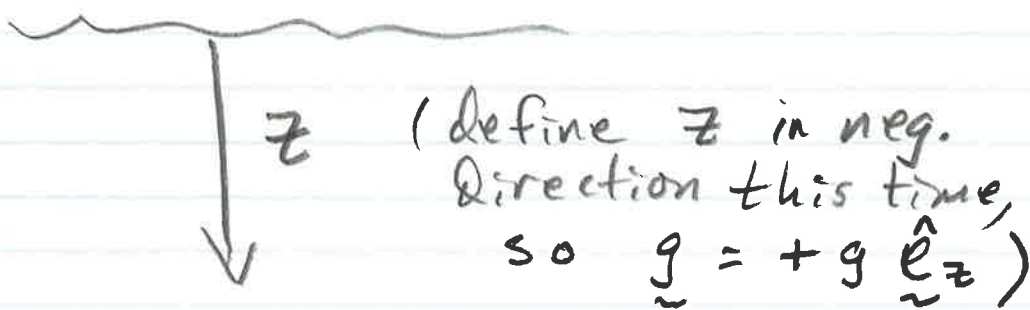

$$\frac{\partial P}{\partial z} = \rho g$$

$$\begin{aligned} P &= P_0 + \rho g z \\ &= P_0 + \underline{1 \text{ atm}} \end{aligned}$$

(39)

$$\text{So } z = \frac{1 \text{ atm}}{89} \quad 1.01325$$

$$\text{Now } 1 \text{ atm} = 1.01 \times 10^6 \frac{\text{dyne}}{\text{cm}^2}$$

$$g = 1 \text{ g/cm}^3 \quad (\text{fresh water})$$

$$g = 980 \frac{\text{cm}}{\text{s}^2} \rightarrow 3.98^\circ\text{C}, \text{ no air!}$$

$$\rightarrow 980.665$$

$$\therefore z = 1033 \text{ cm} = 10.3 \text{ m} \approx \underline{33.9 \text{ ft}}$$

A bit less in salt water!

This suggests an interesting device. Use a semi-permeable membrane (Reverse Osmosis - RO-memb.) that just lets in water & keeps out salt! Stick it on the end of a long pipe & put it in the sea!

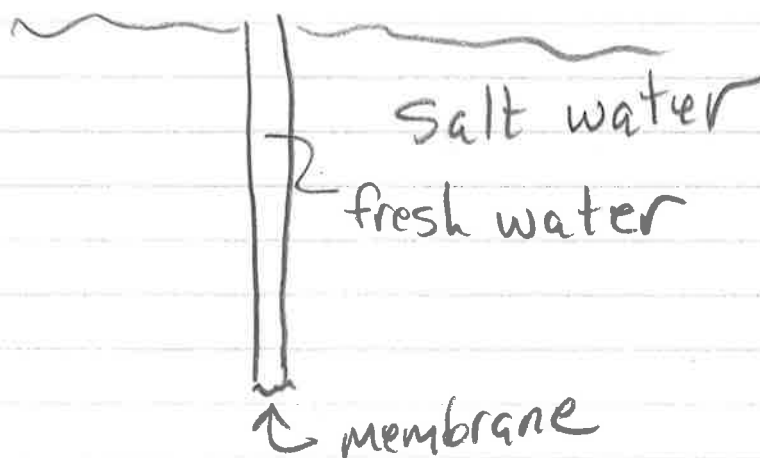

(40)

If the ΔP across the membrane exceeds the osmotic pressure water will flow through the membrane!

How deep must the pipe be to

- (1) get water into the pipe
- (2) get the lighter fresh water all the way to the surface?

$$(1) \quad \rho_{sw} g h_1 = \Delta P_{osm}$$

$$\rho_{sw} = 1.04 \text{ g/cm}^3, \quad \Delta P_{osm} = \underline{28 \text{ atm}}$$

$$\therefore h_1 = 275 \text{ m}!$$

$$(2) \quad \rho_{sw} g h_2 - \rho_{H_2O} g h_2 = \Delta P_{osm}$$

$$\therefore h_2 = \frac{\Delta P_{osm}}{g(\rho_{sw} - \rho_{H_2O})} = 7 \text{ km}!$$

(41)

How about a more practical example?? \Rightarrow Manometer on a tank

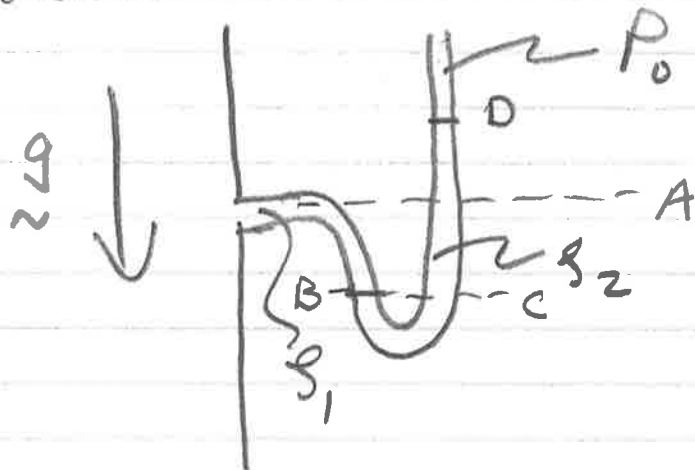

What is the pressure in the tank at pt A?

$$P_A = P_0 + (D - C)\rho_2 g - (A - B)\rho_1 g$$

(no pressure differential between pt B & C!)

Manometers are a simple & useful way to measure ΔP of 0(1 atm) (Hg - not H₂O!) or 0(1 psi) (H₂O)

provided you don't blow them out!

Use electronic or mechanical (spring based) sensors in industry!

Another example: Buoyancy
What is the force exerted by
fluid on a submerged object?

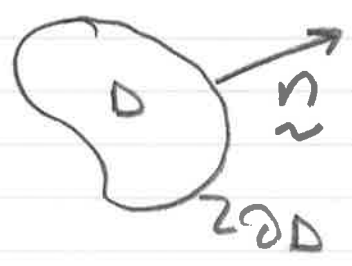

$$\vec{F} = - \int_{\partial D} P \vec{n} dA$$

The pressure distrib in the fluid
is the same as if the object
were absent if it is at rest!
if object absent

So:

$$\vec{F} = - \int_{\partial D} P \vec{n} dA = - \int_D \nabla P dV$$

$$= - \int_V \rho_f \vec{g} dV = - \rho_f \vec{g} V_f$$

So fluid exerts a force equal
to the weight of displaced volume!
(Archimedes, 3rd Cent. B.C.)

OK, let's apply this:

What fraction of an iceberg is submerged?

$$\sum F \approx V \rho_i g - V_s \rho_w g = 0$$

↑
↑
 vol of iceberg vol submerged

$$\therefore \frac{V_s}{V} = \frac{\rho_i}{\rho_w} = \frac{0.917}{1.04} = 0.88$$

So only about 12% is exposed!

Question: If a glass with ice is filled to brim w/ water & ice projects over rim, will it spill when ice melts?? \Rightarrow Nope!

Will it spill if we fill it w/ salt water? \Rightarrow Yep, as water has a lower density!

(44)

Fluids in Motion

Now that we've dealt w/ hydrostatics

let's look at fluids in motion

What sort of questions?? =>

If you have a fire hose w/ some pressure, what floor will it reach?

If you have viscous flow thru a tube, what is the velocity profile?

If you have flow over a wing, what is the lift? drag?

To answer these questions, we invoke

Conservation Laws

What is conserved??

Mass: What goes in - what goes out
= accumulation!

(46)

Also

$$\begin{aligned}\underline{\tilde{x}} &= \underline{\tilde{x}}(\underline{\tilde{x}}_0; t) \\ &= \underline{\tilde{x}}_0 + \int_0^t \underline{u}(\underline{\tilde{x}}_0; t') dt'\end{aligned}$$

which tracks the position of the fluid element starting at $\underline{\tilde{x}}_0$ at $t=0$ for all time!

Lagrangian description isn't used much in fluids - a bit awkward!
When would it be used? \Rightarrow celestial mechanics! Descr. positions of bodies (discrete) as $f^n(t)$

Also - study of suspensions (simulation) - track all the particles in a suspension!

\Rightarrow Also important in pasteurization/related processes

(47)

2. Eulerian Approach: $\underline{u} = \underline{u}(\underline{x}, t)$

Track velocity field at an instant of time relative to defined coord system.

Ex: If you take a snapshot of a highway at time t , you could determine the velocity of all the cars, but you wouldn't know where they came from or where they wind up.

Both Eulerian & Lagrangian descr. can provide a complete descr. of the flow, but for most fluid problems Eulerian is more convenient - we'll focus on it!

other useful concepts:

streamline, pathline, streakline

48

Streamline: curve everywhere tangent to velocity vector at a given instant
⇒ a snapshot of the flow pattern!

→ this is what you get from Eulerian analysis

Pathline: Actual path traversed by a given fluid element - Lagrangian description!

⇒ What you would get from time-lapsed photograph of a marker in a flow field

Streakline: Locus of particles passing thru a given point

⇒ what is usually produced in flow visualization experiments: smoke is released continuously at a point, & pattern is photographed later!

For S.S. flow, all are identical!

(49)

Some unsteady flows may be made steady by shifting coords

Example: falling sphere in viscous fluid. It's moving w.r.t. laboratory reference frame, so flow is unsteady.

If we shift coord system so it travels with sphere, it's steady
=> much more convenient mathematics as we eliminate time!

=> Note: we must use a constant velocity coord system! If we accelerate coord system, leads to non-inertial ref. frame => adds a term to the equations!

=> Also, flow past sphere may still be unsteady at higher Re due to vortex shedding, turbulence.

Another concept: Control Volume ⁽⁵⁰⁾

⇒ You used this in 255, etc.

- Useful for deriving equations:

⇒ treat it as a "black box", keeping track of what goes in & what goes out!

For example: What is the force on a pipe elbow??

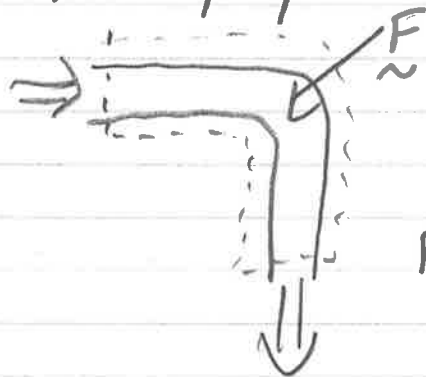

Just do a momentum balance!

Force = momentum out - momentum in!

(remember - momentum & force are vectors!)

Exerts force diagonal to elbow -
Why elbows need bracing!

OK, now we derive eqⁿs:

1) Conservation of mass
(continuity eqⁿ)

We consider a fluid element (cube) as depicted below:

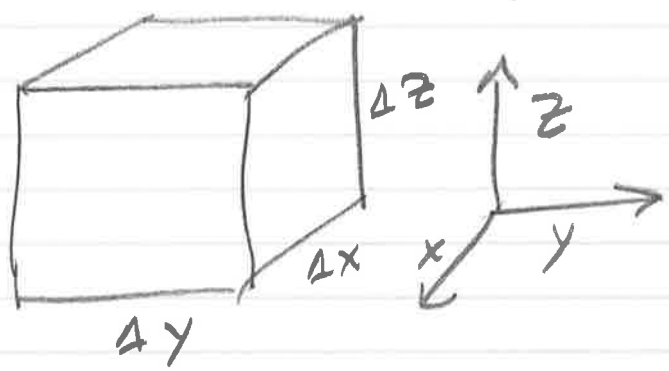

where $\underline{u} \neq 0$!

We have the basic conservation law:

$$\left\{ \begin{array}{l} \text{Rate of accumulation} \\ \text{of mass} \end{array} \right\} = \left\{ \begin{array}{l} \text{Rate in} \\ \text{by convection} \end{array} \right\}$$

since it can't be created!

Since $\underline{u} \neq 0$, fluid (& mass) may come in (or out) thru each face!

What is flux thru face $x = x_0$? 52

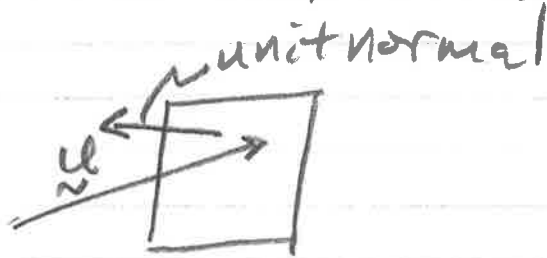

Volumetric flux $\equiv \vec{u} \Rightarrow \frac{\text{Vol}}{\text{Area} \cdot \text{Time}}$

Mass flux $\equiv \rho \vec{u} \Rightarrow \frac{\text{mass}}{\text{Area} \cdot \text{Time}}$

Mass flux thru surface is proportional to component of $\rho \vec{u}$ (a vector) normal to the surface!

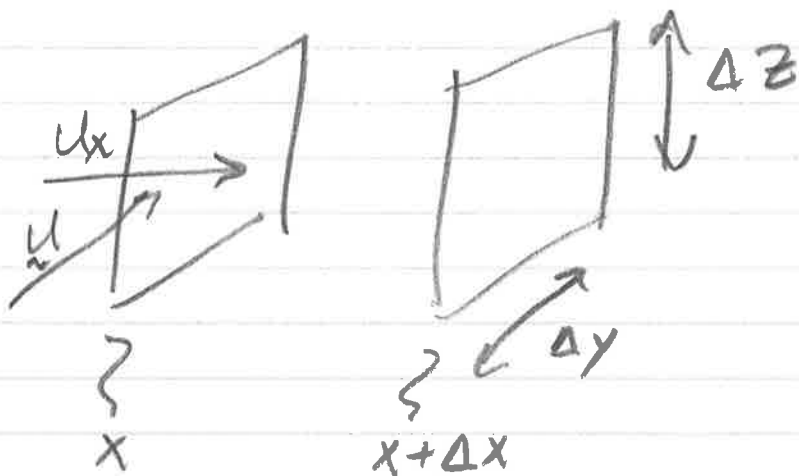

So mass flow in thru these faces is:

(53)

$$(\rho u_x) \Big|_x \Delta y \Delta z - (\rho u_x) \Big|_{x+\Delta x} \Delta y \Delta z$$

And if we combine this with the other faces:

$$\text{Mass into cube} = \left[(\rho u_x) \Big|_x - (\rho u_x) \Big|_{x+\Delta x} \right] \Delta y \Delta z$$

$$+ \left[(\rho u_y) \Big|_y - (\rho u_y) \Big|_{y+\Delta y} \right] \Delta x \Delta z$$

$$+ \left[(\rho u_z) \Big|_z - (\rho u_z) \Big|_{z+\Delta z} \right] \Delta x \Delta y$$

$$= \frac{\partial \rho}{\partial t} (\Delta x \Delta y \Delta z \rho)$$

↳ total mass!

Dividing by $\Delta x \Delta y \Delta z$ & taking the limit as they go to zero yields:

$$\frac{\partial \rho}{\partial t} = - \left(\frac{\partial (\rho u_x)}{\partial x} + \frac{\partial (\rho u_y)}{\partial y} + \frac{\partial (\rho u_z)}{\partial z} \right)$$

or,

$$\frac{\partial \rho}{\partial t} = -\nabla \cdot (\rho \underline{u})$$

In words: The time rate of change of the density is the negative of the divergence of the mass flux vector!

We can rearrange this:

$$\frac{\partial \rho}{\partial t} = -\rho \nabla \cdot \underline{u} - \underline{u} \cdot \nabla \rho$$

or

$$\frac{\partial \rho}{\partial t} + \underline{u} \cdot \nabla \rho = -\rho \nabla \cdot \underline{u}$$

This is known as the material derivative

$$\frac{D\phi}{Dt} \equiv \frac{\partial \phi}{\partial t} + \underline{u} \cdot \nabla \phi$$

for any ϕ !

Remember the Lagrangian description?

$\frac{D\phi}{Dt}$ is the time rate of change of any property ϕ experienced by a fluid element!

It has two components:

- 1) $\frac{\partial \phi}{\partial t} \Rightarrow$ local deriv. w.r.t. time
- 2) $\underline{u} \cdot \nabla \phi \Rightarrow$ change due to convection thru a field where ϕ varies with position

If a fluid is incompressible we have $\rho = \text{cst}$

Thus $\frac{D\rho}{Dt} \equiv 0$

and thus $\nabla \cdot \underline{u} = 0$

(56)

An alternate derivation may be made using vector calculus. Consider an arbitrary control volume D :

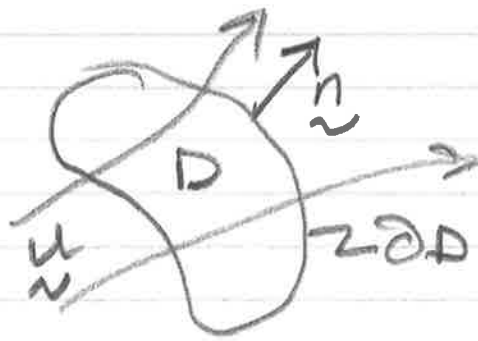

What is the change in the total mass in D ?

$$\frac{dm}{dt} = \frac{d}{dt} \int_D \rho \, dV \equiv \int_D \frac{\partial \rho}{\partial t} \, dV$$

$$= \int_{\partial D} \underbrace{-\rho \underline{u} \cdot \underline{n}}_{\text{mass flux in}} \, dA$$

\hookrightarrow mass flux in thru each patch of surface!

(57)

Thus :

$$\int_D \frac{\partial \rho}{\partial t} dV + \int_{\partial D} \rho \underline{u} \cdot \underline{n} dA = 0$$

Apply Divergence theorem:

$$\int_D \frac{\partial \rho}{\partial t} dV + \int_D \nabla \cdot (\rho \underline{u}) dV = 0$$

$$\text{or } \frac{\partial \rho}{\partial t} + \nabla \cdot (\rho \underline{u}) = 0$$

Which is the same equation!

In index notation:

$$\frac{\partial \rho}{\partial t} + \frac{\partial (\rho u_i)}{\partial x_i} = 0$$

or

$$\frac{\partial \rho}{\partial t} + u_i \frac{\partial \rho}{\partial x_i} = -\rho \frac{\partial u_i}{\partial x_i}$$

All are equivalent

An example:

Let's look at a hydraulic jack.

This is an example of how a small pump can raise a big car!

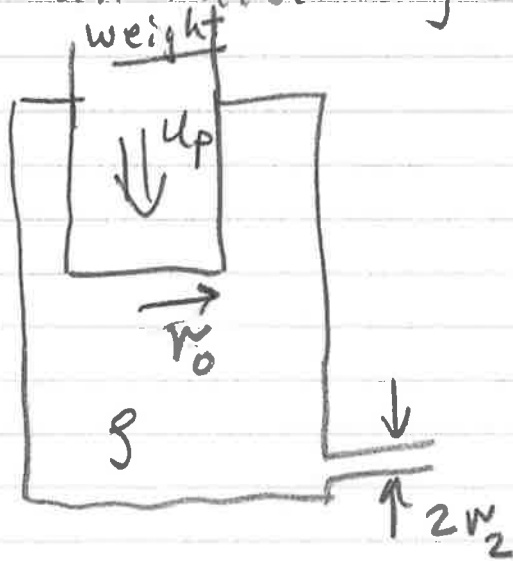

For a given motion of the piston, what is the flow rate thru the outlet pipe? For a given weight of car, what is the pressure in the pipe?

To get the flow rate we use 59
the CE:

$$\frac{\partial \rho}{\partial t} + \nabla \cdot (\rho \underline{u}) = 0$$

We take the fluid to be incompressible, so the density is const

\therefore

$$\nabla \cdot \underline{u} = 0$$

We draw a control volume:

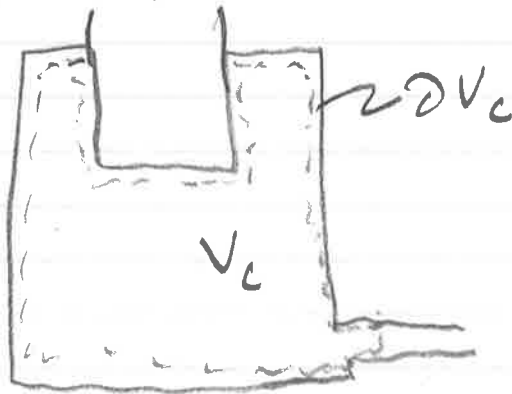

$$\int_{V_c} \nabla \cdot \underline{u} \, dV = \int_{\partial V_c} \underline{u} \cdot \underline{n} \, dA = 0$$

Fluid in = Fluid out!

(60)

$\underline{u} \cdot \underline{n} \neq 0$ only in exit pipe face
& at piston face!

Let A_e be exit pipe, A_p be piston

$$\int_{A_p} \underline{u} \cdot \underline{n} \, dA + \int_{A_e} \underline{u} \cdot \underline{n} \, dA = 0$$

Now flow out through piston is

$$- A_p u_p \quad (\underline{u} \cdot \underline{n} \text{ is } \underline{\text{negative}} \text{ here})$$

Flow out through exit pipe is

$$+ A_e \langle u_e \rangle$$

(we define average velocity

$$\langle u_e \rangle = \frac{1}{A_e} \int_{A_e} \underline{u}_e \cdot \underline{n} \, dA$$

Thus the average velocity:

$$\langle u_e \rangle = \frac{A_p}{A_e} u_p$$

(61)

So the ratio of the average inlet velocity to the average outlet velocity is inverse of the ratios of the areas!

Note: the CE tells you about the average velocity normal to the exit, it doesn't tell you about the velocity distribution

If there's no flow, what is the pressure at the exit?

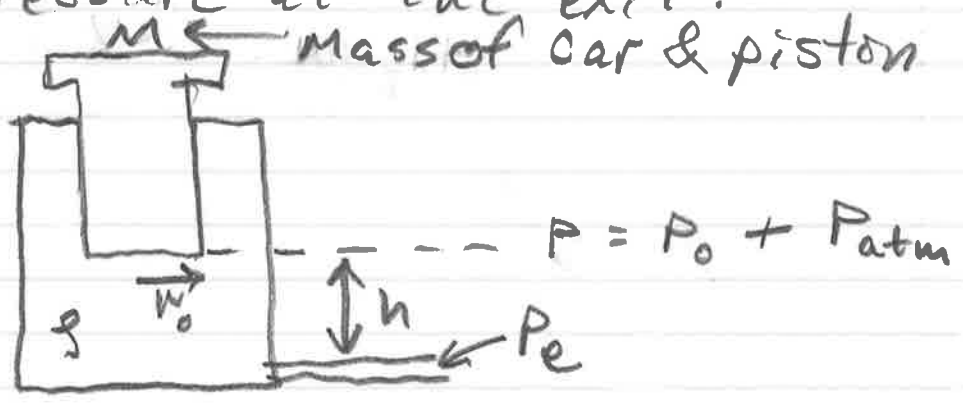

$$P_0 = \frac{F}{A} = \frac{Mg}{\pi v_0^2}$$

(62)

$$P_e = P_0 + P_{atm} + \rho g h$$

What is the force required to raise the piston?

$$F = (P_e - P_{atm}) A_e$$

$$= \left(\frac{Mg}{\pi r_0^2} + \rho g h \right) \pi r_e^2$$

$$= Mg \underbrace{\frac{r_e^2}{r_0^2}}_{\substack{\text{ratio reduces} \\ \text{required} \\ \text{force!}}} + \underbrace{\pi r_e^2 \rho g h}_{\text{small (usually)}}$$

This is how hydraulics work!

Examples: car brakes, wing elevators, hydraulic jacks, etc.

Note: energy expended to raise car is unchanged, but force is reduced!

63

Let's extend the CE to multi-component systems

Suppose we have m species, (e.g., salt sol'n $H_2O, NaCl : m=2$)

we can do a balance on each species:



Let velocity of species i be given by \underline{u}_i (OK, not index notation here - subscript represents which species we're talking about)

Note: \underline{u}_i will, in general, be different from mass avg. velocity \underline{u} due to diffusion!

Let density of species i (mass/vol) be $\rho_i \Rightarrow$ Note this is not the

the density of salt (say) ⁶⁴ but
rather the mass/volume of
salt in the solution! OK,
we still have conservation for
each species

$$\frac{d}{dt} \int_D \rho_i dV = - \int_{\partial D} \rho_i \vec{u}_i \cdot \vec{n} dA + \int_D R_i dV$$

$R_i \Rightarrow$ mass rate of production
per unit volume of species i
due to reaction!

We can apply divergence theorem
to this:

(65)

$$\int_D \frac{\partial \rho_i}{\partial t} dV + \int_D \nabla \cdot (\rho_i \underline{u}_i) dV = \int_D R_i dV$$

or the microscopic eqⁿ:

$$\frac{\partial \rho_i}{\partial t} + \nabla \cdot (\rho_i \underline{u}_i) = R_i$$

The total density is just the sum of ρ_i :

$$\rho = \sum \rho_i$$

& mass avg velocity:

$$\rho \underline{u} = \sum \rho_i \underline{u}_i$$

Thus summing the equation over all species:

$$\frac{\partial}{\partial t} \sum \rho_i + \nabla \cdot (\sum \rho_i \underline{u}_i) = \sum R_i \quad (66)$$

or:

$$\frac{\partial \rho}{\partial t} + \nabla \cdot (\rho \underline{u}) = \sum R_i$$

Note that $\sum R_i = \underline{0}$ since mass is conserved in reacting systems!

Next semester you will combine this equation with Fick's law to get the equation governing mass transfer!

OK, let's work another example: Conservation of mass in a CSTR (continuously stirred Tank Reactor)

(67)

Suppose we have a well-mixed (stirred) tank :

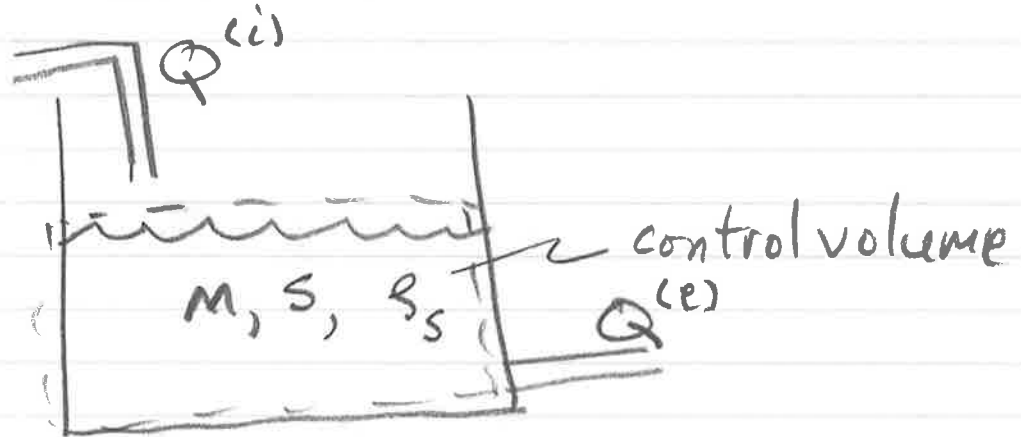

We have a mass flow rate Q

$Q^{(i)} \Rightarrow$ inlet mass flow

$Q^{(e)} \Rightarrow$ exit mass flow

$$M = \text{mass in tank} = \int_0 \rho \, dV$$

$\rho \equiv$ total density

$$S \equiv \text{salt in tank} = \int_0 \rho_s \, dV$$

$\rho_s \equiv$ density of salt

We wish to determine the ⁽⁶⁸⁾ fluid level & salt concentration as a function of time!

$$\{ \text{mass in} \} - \{ \text{mass out} \} = \{ \text{accum.} \}$$

Thus:

$$\begin{aligned} \frac{dM}{dt} &= - \int_{\partial D} \rho (\underline{u} \cdot \underline{n}) dA \\ &= Q^{(i)} - Q^{(e)} \end{aligned}$$

$$\begin{aligned} \frac{dS}{dt} &= - \int_{\partial D} \rho_s (\underline{u} \cdot \underline{n}) dA \\ &= Q^{(i)} \frac{\rho_s^{(i)}}{\rho^{(i)}} - Q^{(e)} \frac{\rho_s^{(e)}}{\rho^{(e)}} \end{aligned}$$

$\omega_s^{(i)} \Rightarrow$ mass fraction at inlet

(69)

Now for a CSTR,

$$\frac{S_s^{(e)}}{Q^{(e)}} = \frac{S}{M} \quad (\text{tank is well mixed})$$

Hence

$$\frac{QS}{Qt} = Q^{(i)} w_s^{(i)} - \left(\frac{S}{M}\right) Q^{(e)}$$

$$\frac{QM}{Qt} = Q^{(i)} - Q^{(e)} = \Delta Q$$

Solution: solve for M first, then solve for S!

$$M = M_0 + \Delta Q t \quad (\text{linear change in time})$$

$$\frac{QS}{Qt} = \frac{-Q^{(e)}}{M_0 + \Delta Q t} S + Q^{(i)} w_s^{(i)}$$

(70)

or

$$\frac{ds}{dt} + \left\{ \frac{Q^{(e)}}{M_0 + AQt} \right\} s = Q^{(i)} \omega_s^{(i)}$$

$$\text{w/ I.C. } s \Big|_{t=0} = s_0$$

This is a first order linear ODE

We have the general solution.

$$\frac{dy}{dx} + p(x)y = f(x)$$

$$\text{Then: } y(x) = e^{-\int p(x) dx} \left[\int [f(x) e^{\int p(x) dx}] dx + K \right]$$

where K is determined from I.C.!

Let's apply this:

$$x \equiv t, \quad f(x) \equiv Q^{(i)} \omega_s^{(i)} = \text{cst}$$

(71)

$$p(x) \equiv \frac{Q^{(e)}}{M_0 + \Delta Q t}$$

So:

$$\int p(t) dt = \frac{Q^{(e)}}{\Delta Q} \ln \left(\frac{M_0}{\Delta Q} + t \right)$$

and thus:

$$- \left[\frac{Q^{(e)}}{\Delta Q} \ln \left(\frac{M_0}{\Delta Q} + t \right) \right]$$

$$S = e$$

$$\bullet \left[\int Q^{(i)} \omega_s^{(i)} e^{\left[\frac{Q^{(e)}}{\Delta Q} \ln \left(\frac{M_0}{\Delta Q} + t \right) \right]} dt + K \right]$$

Now $e^{\left[\frac{Q^{(e)}}{\Delta Q} \ln \left(\frac{M_0}{\Delta Q} + t \right) \right]} \equiv \left(\frac{M_0}{\Delta Q} + t \right)^{\left(\frac{Q^{(e)}}{\Delta Q} \right)}$

Thus:

$$S = \left(\frac{M_0}{\Delta Q} + t \right)^{-\frac{Q^{(e)}}{\Delta Q}} \left[\int Q^{(i)} \omega_s^{(i)} \left(\frac{M_0}{\Delta Q} + t \right)^{\left(\frac{Q^{(e)}}{\Delta Q} \right)} dt + K \right]$$

$$= \left(\frac{M_0}{\Delta Q} + t \right)^{-\frac{Q^{(e)}}{\Delta Q}} \left[Q^{(i)} \omega_s^{(i)} \frac{\left(\frac{M_0}{\Delta Q} + t \right)^{\left(\frac{Q^{(e)}}{\Delta Q} + 1 \right)}}{\left(\frac{Q^{(e)}}{\Delta Q} + 1 \right)} + K \right]$$

$$= Q^{(i)} \omega_s^{(i)} \frac{\left(\frac{M_0}{\Delta Q} + t\right)}{\left(\frac{Q^{(e)}}{\Delta Q} + 1\right)} + K \left(\frac{M_0}{\Delta Q} + t\right)^{-\frac{Q^{(e)}}{\Delta Q}}$$

We determine K from the I.C.

$$S|_{t=0} = S_0$$

Thus:

$$S_0 = Q^{(i)} \omega_s^{(i)} \frac{\frac{M_0}{\Delta Q}}{\left(\frac{Q^{(e)}}{\Delta Q} + 1\right)} + K \left(\frac{M_0}{\Delta Q}\right)^{-\frac{Q^{(e)}}{\Delta Q}}$$

$$\text{So } K = S_0 \left(\frac{M_0}{\Delta Q}\right)^{\frac{Q^{(e)}}{\Delta Q}} - Q^{(i)} \omega_s^{(i)} \frac{\left(\frac{M_0}{\Delta Q}\right)^{\left(\frac{Q^{(e)}}{\Delta Q} + 1\right)}}{\left(\frac{Q^{(e)}}{\Delta Q} + 1\right)}$$

Which yields:

$$S = S_0 \left(\frac{\frac{M_0}{\Delta Q}}{\frac{M_0}{\Delta Q} + t}\right)^{\frac{Q^{(e)}}{\Delta Q}} + \frac{Q^{(i)} \omega_s^{(i)}}{\left(\frac{Q^{(e)}}{\Delta Q} + 1\right)} \times$$

$$\left[\left(\frac{M_0}{\Delta Q} + t\right) - \left(\frac{M_0}{\Delta Q} + t\right)^{-\frac{Q^{(e)}}{\Delta Q}} \left(\frac{M_0}{\Delta Q}\right)^{\left(\frac{Q^{(e)}}{\Delta Q} + 1\right)} \right]$$

$$= S_0 \left(\frac{M_0}{M_0 + \Delta Q t} \right) \frac{Q^{(re)}}{\Delta Q} + \frac{Q^{(i)} \omega_s^{(i)}}{\left(\frac{Q^{(re)}}{\Delta Q} + 1 \right)} \times$$

$$\left(\frac{M_0}{\Delta Q} + t \right) \left[1 - \left(\frac{\frac{M_0}{\Delta Q}}{\frac{M_0}{\Delta Q} + t} \right) \left(\frac{Q^{(re)}}{\Delta Q} + 1 \right) \right]$$

Note: $\frac{Q^{(re)}}{\Delta Q} + 1 = \frac{1}{\Delta Q} (Q^{(re)} + Q^{(i)} - Q^{(re)})$
 $= \frac{Q^{(i)}}{\Delta Q}$

So:

$$S = S_0 \left(\frac{M_0}{M_0 + \Delta Q t} \right) \frac{Q^{(re)}}{\Delta Q} + \omega_s^{(i)} (M_0 + \Delta Q t) \left(1 - \left(\frac{M_0}{M_0 + \Delta Q t} \right) \frac{Q^{(i)}}{\Delta Q} \right)$$

The first term results from the loss of the salt initially present in the tank. The second results from that added to the tank.

(74)

We can simplify a bit further if we recall:

$$M = M_0 + \Delta Q t$$

Thus:

$$S = S_0 \left(\frac{M_0}{M} \right)^{\frac{Q^{(re)}}{\Delta Q}}$$

$$+ \omega_s^{(i)} M \left(1 - \left(\frac{M_0}{M} \right)^{\frac{Q^{(i)}}{\Delta Q}} \right)$$

It is interesting to note that in the limit $\Delta Q \rightarrow 0$ (e.g., $Q^{(re)} = Q^{(i)}$) the power law form given here collapses to a pure exponential:

$$M = M_0 \quad Q = Q^{(re)} = Q^{(i)}$$

$$S = M_0 \omega_s^{(i)} + (S_0 - M_0 \omega_s^{(i)}) e^{-\frac{Q}{M_0} t}$$

The quantity M_0/Q is known as the Residence Time of the vessel!

Conservation of Momentum

Just as was the case for mass, momentum is also conserved.

For mass we had:

$$\left\{ \begin{array}{l} \text{accum of} \\ \text{mass} \end{array} \right\} = - \left\{ \begin{array}{l} \text{net rate out} \\ \text{by convection} \end{array} \right\}$$

or:

$$\int_V \frac{\partial \rho}{\partial t} dV = - \int_{\partial V} \rho \underline{u} \cdot \underline{n} dA$$

For momentum it's a bit messier:

$$\left\{ \begin{array}{l} \text{accum of} \\ \text{momentum} \end{array} \right\} = - \left\{ \begin{array}{l} \text{net rate momentum} \\ \text{out by convection} \end{array} \right\}$$

$$+ \left\{ \begin{array}{l} \text{sum of forces on} \\ \text{D by surroundings} \end{array} \right\}$$

Force adds momentum via

$$\underline{F} = m \underline{a} \quad (\text{rate of increase of momentum})$$

(76)

What do these terms look like?

$$\rho \underline{u} \equiv \text{momentum per unit volume}$$

Thus:

$$\left\{ \begin{array}{l} \text{Rate momentum out} \\ \text{by convection} \end{array} \right\} \equiv \int_{\partial D} (\rho \underline{u}) \underline{u} \cdot \underline{n} \, dA$$

$$\frac{\text{momentum}}{\text{volume}} \times \text{volumetric flux normal to surface}$$

= momentum flux!

What is the total momentum in D ?

$$\rho \underline{u} \equiv \text{momentum/volume}$$

Thus accumulation is:

$$\int_D \frac{\partial}{\partial t} (\rho \underline{u}) \, dV$$

Combining these terms:

(77)

$$\int_0 \frac{\partial (\rho \underline{u})}{\partial t} \rho V + \int_{\partial D} (\rho \underline{u}) \underline{u} \cdot \underline{n} \rho A$$

$$= \sum \underline{F} \quad (\text{sum of forces on Control Volume})$$

Ok, what are the forces? we looked at these before!

Body forces (e.g., gravity)

$$\underline{F}_g = \int_0 \rho \underline{g} \rho V$$

Surface forces

These include normal forces (e.g., pressure) and shear forces

The latter results from "dragging" along (tangential to) a surface!

Let \vec{f} be all surface forces 78
at a point.

Thus:

$$\sum \vec{F} = \int_D \rho \vec{g} dV + \int_{\partial D} \vec{f} dA$$

$$\vec{f} \equiv \frac{\text{force}}{\text{area}} \equiv \text{surface stress}$$

Recall from our earlier examination
of hydrostatics that:

$$\vec{f} = \underline{\underline{\sigma}} \cdot \underline{\underline{n}}$$

where $\underline{\underline{\sigma}}$ is the stress tensor

we'll use this in a bit.

For now we have:

(79)

$$\int_V \frac{\partial(\rho \underline{u})}{\partial t} QV + \int_{\partial D} (\rho \underline{u}) \underline{u} \cdot \underline{n} QA =$$

$$\int_D \rho \underline{g} QV + \int_{\partial D} \underline{f} QA$$

How can we use this? \Rightarrow We can calculate the force on an elbow!

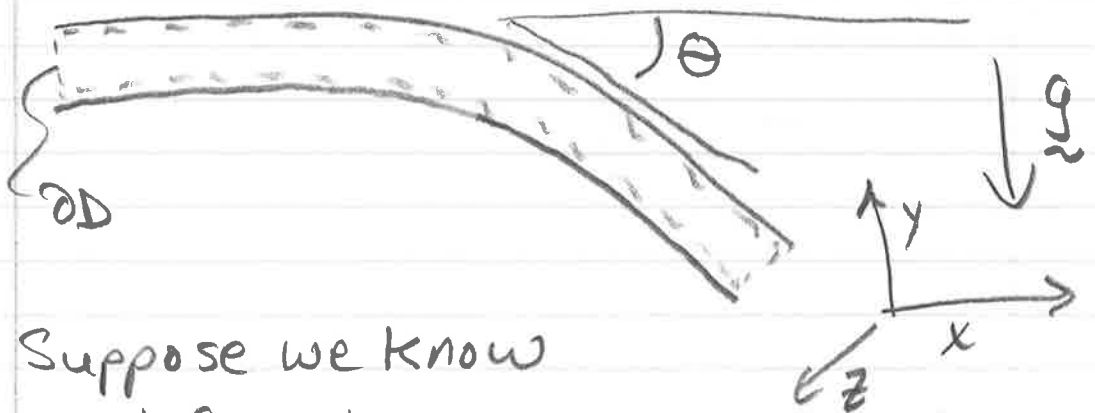

Suppose we know inlet & outlet pressures as well as the flow rate. We want to know the force exerted by the fluid on the bend (section of pipe) which is $(-)$ force exerted by bend on fluid!

(80)

We have the momentum balance:

$$\int_D \rho \underline{g} \, dV + \int_{\partial D} \underline{f} \, dA = \int_{\partial D} (\rho \underline{u}) \underline{u} \cdot \underline{n} \, dA + \int_D \frac{\partial (\rho \underline{u})}{\partial t} \, dV$$

We assume we are at

Steady State, thus $\frac{\partial}{\partial t} \equiv 0$

If the fluid is incompressible

$$\int_D \rho \underline{g} \, dV = \rho \underline{g} V_D \equiv \text{weight of water!}$$

Now for the surface integrals:

We divide up ∂D into $A_i, A_e, A_p,$

e.g.,



(81)

Let's look at the convection term:

$$\int_{\partial D} (\rho \underline{u}) \underline{u} \cdot \underline{n} \, dA = \int_{A_i} (\rho \underline{u}) \underline{u} \cdot \underline{n} \, dA \\ + \int_{A_p} (\rho \underline{u}) \underline{u} \cdot \underline{n} \, dA + \int_{A_e} (\rho \underline{u}) \underline{u} \cdot \underline{n} \, dA$$

Over the pipe itself (A_p) $\underline{u} \cdot \underline{n} = \underline{0}$
(no flow through the pipe), thus we
just get integrals over inlet & exit!

⇒ Unlike mass conservation, we can't
evaluate integrals exactly without
knowing the velocity profile ($\underline{u}(r)$)
across the pipe in addition to the
total flow rate Q

This is because the integral is
non-linear in \underline{u} !

To estimate the force we shall 82
assume we have uniform flow

$$\text{Let's take } \underline{u} \Big|_{A_i} \approx \frac{Q}{A_i} \hat{\underline{e}}_x$$

$$\text{Now at the inlet } \underline{n} \Big|_{A_i} = -\hat{\underline{e}}_x$$

Thus :

$$\int_{A_i} (\rho \underline{u}) \underline{u} \cdot \underline{n} \, dA \approx \int_{A_i} \left(\rho \frac{Q}{A_i} \hat{\underline{e}}_x \right) \left(\frac{Q}{A_i} \hat{\underline{e}}_x \cdot (-\hat{\underline{e}}_x) \right) dA$$

$$\hat{\underline{e}}_x \cdot (-\hat{\underline{e}}_x) = -1$$

So we get :

$$= -\rho \frac{Q^2}{A_i} \hat{\underline{e}}_x$$

which is negative

because momentum is going into CV!

Note that this underestimates the momentum flux (in general).

This is because non-uniformities
 in u increase the momentum
 flux over a uniform velocity!
 \Rightarrow The average of the square is
 always greater than or equal
 to the square of the average!

$$\text{Let } \langle u \rangle = \frac{1}{A} \int_A u \, dA$$

$$\text{Let } \Delta u = u - \langle u \rangle$$

$$\text{So: } \int_A u^2 \, dA = \int_A (\Delta u + \langle u \rangle)^2 \, dA$$

$$= \int_A \langle u \rangle^2 \, dA + \int_A (\Delta u)^2 \, dA$$

$$+ 2 \langle u \rangle \int_A \Delta u \, dA$$

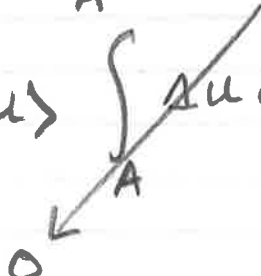

(84)

since $\int_A (\Delta u)^2 dA \geq 0$

we have:

$$\int_A \rho u^2 dA \geq \int_A \rho \left(\frac{Q}{A}\right)^2 dA$$

so we underestimate the momentum flux. For high Re (turbulence) the profile is nearly flat (uniform), so it's not a big error!

Over the exit we have the same integral:

$$\underline{u} \Big|_{A_e} \cong \frac{Q}{A_e} \hat{e}_\theta, \quad \hat{e}_\theta = \cos\theta \hat{e}_x + \sin\theta \hat{e}_y$$

The unit normal: $\underline{n} \Big|_{A_e} = \hat{e}_\theta$

So:

$$\int_{A_e} \rho \underline{u} (\underline{u} \cdot \underline{n}) dA = \rho \frac{Q^2}{A_e} \hat{e}_\theta$$

Putting these together:

85

$$\int_{\partial D} (\rho \underline{u}) (\underline{u} \cdot \underline{n}) dA \approx \rho Q^2 \left(-\frac{\hat{e}_x}{A_i} + \frac{\hat{e}_0}{A_e} \right)$$

Note that since $\hat{e}_x \neq \hat{e}_0$ the force will be non-zero even if $A_i \neq A_e$.
A force is required to deflect a stream!

OK, now we look at the surface forces:

$$\int_{\partial D} \underline{f} dA \equiv \int_{A_i} \underline{f} dA + \int_{A_e} \underline{f} dA + \int_{A_p} \underline{f} dA$$

The last one is what we're after!

Let's do the first term:

$$\int_{A_i} \underline{f} dA \equiv \text{Force exerted by fluid outside CV on CV integrated over } A_i$$

This force is complex, but 86
we will approximate it by assuming
it's just the normal force:

$$\vec{f} \Big|_{A_i} \approx P_i \hat{e}_x$$

↘ pressure at A_i

So:

$$\int_{A_i} \vec{f} dA \approx P_i A_i \hat{e}_x$$

$$\int_{A_e} \vec{f} dA \approx -P_e A_e \hat{e}_x \quad (\text{force is in } -\hat{e}_x \text{ direction})$$

Finally, $\int_{A_p} \vec{f} dA \equiv \vec{F}_p$, force exerted
by the pipe on the fluid!

(87)

Putting it all together:

$$\frac{d}{dt} \int_D \rho \vec{u} dV + \int_{\partial D} (\rho \vec{u}) \vec{u} \cdot \vec{n} dA$$

$$= \int_D \rho \vec{g} dV + \int_{\partial D} \vec{F} dA$$

Or:

$$\rho Q^2 \left(\frac{-\hat{e}_x}{A_i} + \frac{\hat{e}_0}{A_e} \right) = -\rho g V_D \hat{e}_y$$
$$+ P_i A_i \hat{e}_x - P_e A_e \hat{e}_0 + \vec{F}_P$$

Or, rearranging,

$$\vec{F}_P = \rho Q^2 \left(\frac{-\hat{e}_x}{A_i} + \frac{\hat{e}_0}{A_e} \right) + \rho g V_D \hat{e}_y$$
$$- P_i A_i \hat{e}_x + P_e A_e \hat{e}_0$$

This is a vector equation! We can look at the x component:

(88)

$$(F_p)_x = \vec{F}_p \cdot \hat{e}_x = \rho Q^2 \left(\frac{-1}{A_i} + \frac{\cos \theta}{A_e} \right)$$

$$- P_i A_i + P_e A_e \cos \theta$$

or the y-component:

$$(F_p)_y = \vec{F}_p \cdot \hat{e}_y = \rho Q^2 \left(- \frac{\sin \theta}{A_e} \right)$$

$$+ \rho g V_D - P_e A_e \sin \theta$$

These forces could be used to determine the required bracing, for example!

89

Let's work through another example:

Water jet pushing a car. Suppose we have a car with a plate sticking up as below:

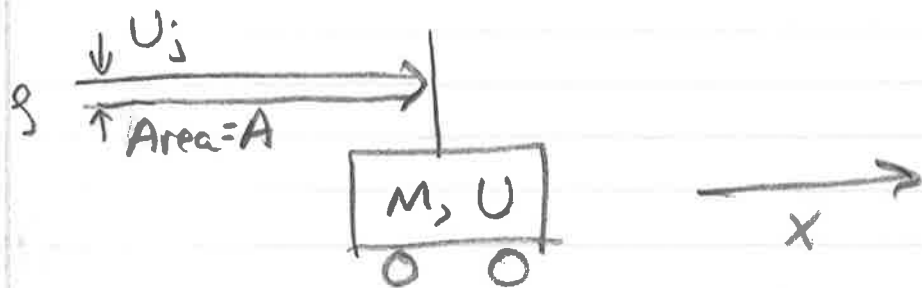

A jet of water of diameter D & velocity U_j impinges on the plate. What is the force on the plate as a function of U ? What is the velocity of the car as a function of time?

To solve, look at problem in a reference frame moving with the plate!

(90)

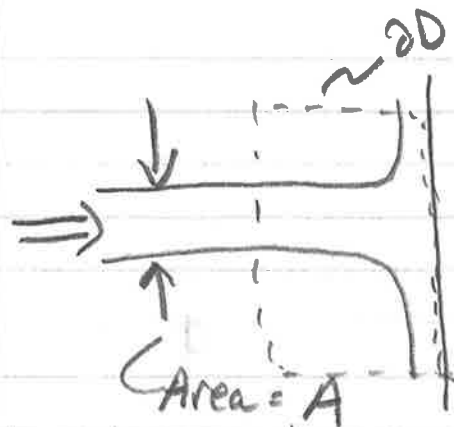

Water velocity in this frame is now $(U_j - U)$, not U_j !

We draw the CV as depicted.

We have:

$$\sum_{\partial D} \vec{F} = \int_{\partial D} (\rho \vec{u}) \vec{u} \cdot \vec{n} dA$$

We are interested in the x-component of this force. Since the fluid leaves ∂D with a velocity only in the y-direction, we just worry about the inlet

(91)

Thus:

$$F_x = A (\rho (U_j - U)) (- (U_j - U))$$

↑
negative
because fluid
is entering

So the force on the fluid
is just

$$F_x = -A\rho (U_j - U)^2$$

The force on the car is the
negative of this!

Now since $F = M \frac{dU}{dt}$

we have:

$$\frac{dU}{dt} = \frac{A\rho}{M} (U - U_j)^2$$

we can solve this:

$$\frac{1}{(U - U_j)^2} \frac{dU}{dt} = \frac{A\rho}{M}$$

(92)

$$\frac{d}{dt} \left(\frac{1}{U - U_j} \right) = - \frac{A S}{M}$$

$$\frac{1}{U - U_j} = - \frac{A S}{M} t + C$$

$$\text{Let } U \Big|_{t=0} = 0$$

$$\therefore C = - \frac{1}{U_j}$$

$$\text{So } \frac{1}{U - U_j} = - \frac{A S t}{M} - \frac{1}{U_j}$$

$$\frac{U}{U_j} = 1 - \frac{1}{\frac{A S U_j t}{M} + 1}$$

$$= \frac{\frac{A S U_j t}{M}}{1 + \frac{A S U_j t}{M}}$$

So U asymptotically approaches U_j as we would expect.

93

We can get a much higher force & acceleration if we modify the plate so it sends water back out in the reverse direction

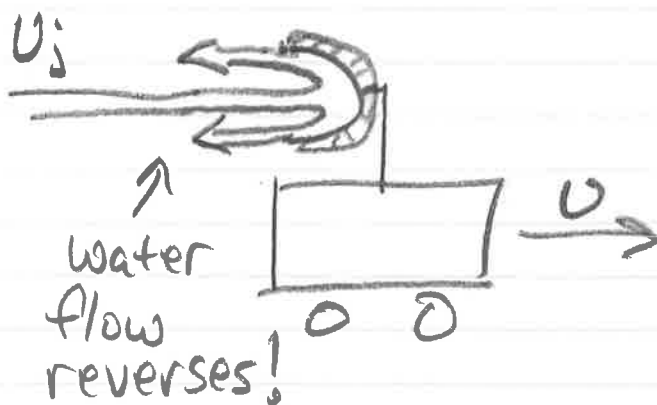

In the moving reference frame we still have:

$$\Sigma \underline{F} = \int_{\partial D} (\rho \underline{u}) \underline{u} \cdot \underline{n} dA$$

but now u_x is reversed for the fluid leaving ∂D rather than just zero. This doubles the momentum transfer!

(94)

$$F_x = -2A\rho(U_j - U)^2$$

(force on fluid)

So:

$$\frac{dU}{dt} = 2 \frac{A\rho}{M} (U - U_j)^2$$

or

$$\frac{U}{U_j} = \frac{2 \frac{A\rho U_j t}{M}}{1 + 2 \frac{A\rho U_j t}{M}}$$

The asymptotic velocity is still U_j ,

it just gets there twice as fast!

This effect is why ^{in a} Pelton wheel

(a type of turbine) the buckets are

curved - more efficient momentum

& energy transfer

94A

Let's analyze the Pelton Wheel:

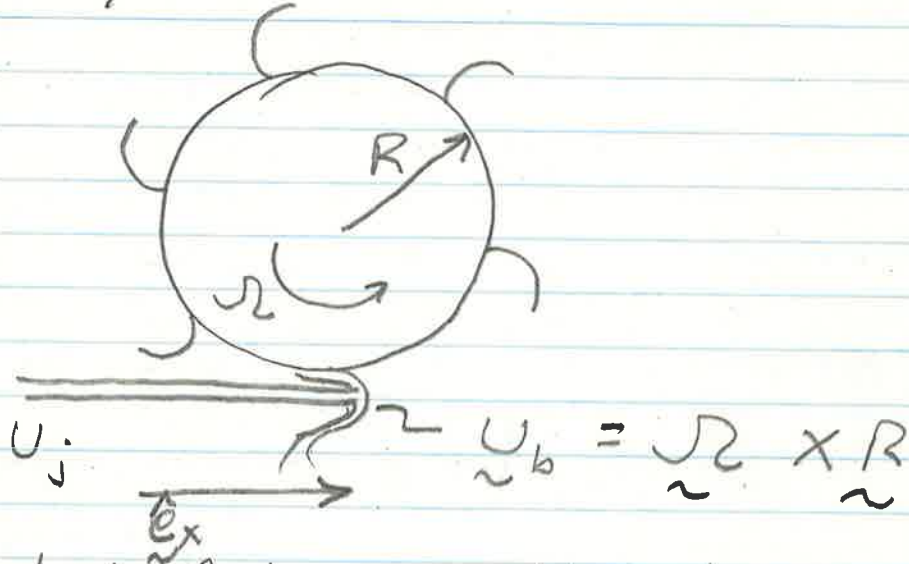

We wish to determine the torque on the wheel, and the rate of work (Power) transferred to it!

First for the torque:

$$\underline{M} = \underline{F} \times \underline{R}$$

The force is just the change in momentum of the stream! To get this, we need the exit velocity U_e . We have the two cases for different vanes: flat plate & reflection:

94B

$$F_x = Q \left[(\rho U_j - \rho U_e) \right] \cdot \hat{e}_x$$

\uparrow vol. flow rate \uparrow mom/vol in \leftarrow mom/vol out

force on vane (neg. of force on fluid)

Only the x-component of the force contributes to the torque! (Perp. to \vec{R})

OK, for the flat plate we have:

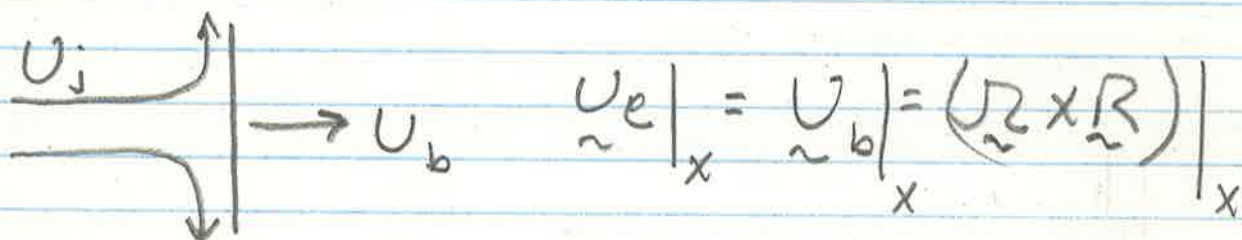

Thus for this case

$$F_x = Q \left[(\rho U_j - \rho \Omega R) \right]$$

The torque is $F_x R$.

What about the power?

$$P = \vec{M} \cdot \vec{\Omega} = F_x R \Omega$$

$$= Q R \Omega \left[(\rho U_j - \rho \Omega R) \right]$$

(94C)

Note that the torque is maxed when $\Omega = 0$ but the power is zero!

What is the value of Ω for which the power is max?

$$\frac{\partial P}{\partial \Omega} = 0 = QR \left[gU_j - 2g\Omega_m R \right]$$

$$\therefore gU_j = 2g\Omega_m R$$

$$\text{or } \Omega_m R = \frac{U_j}{2}$$

so the vanes move with half the velocity of the jet. The max power is:

$$P_m = Q \frac{U_j}{2} \left[(gU_j - \frac{1}{2}gU_j) \right]$$

$$= \frac{1}{2} Q \left(\frac{1}{2}gU_j^2 \right) \text{ which is } \underline{\text{half}} \text{ the}$$

total kinetic energy of the stream!

Now for curved buckets:

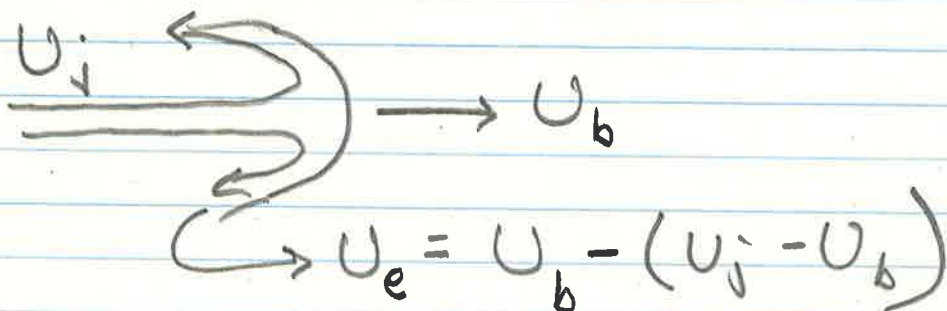

This yields a force:

$$\begin{aligned}
 F_x &= Q[(\rho U_j + \rho U_e)] \\
 &= Q[\rho U_j + \rho U_j - 2\rho U_b] \\
 &= 2Q[\rho U_j - \rho \Omega R]
 \end{aligned}$$

which is twice the force (and torque, and power) of the flat vanes!

At the optimum (same) rotation rate, we have:

$$P_m = Q \left(\frac{1}{2} \rho U_j^2 \right)$$

or all the kinetic energy of the jet is extracted. A real water wheel would lie between these values.

Microscopic Momentum Balances

So far we've done our calculations by assuming velocity profiles were flat (Uniform). This, in general, is not correct! To get it right, we need to calculate the velocity profile. We need to develop the equation which governs the velocity everywhere in the fluid.

To do this, we need to reexamine the stress tensor $\underline{\underline{\sigma}}$

Look at the flow between parallel plates:



Fluid resists deformation ⁽⁹⁶⁾ so a force F is required to keep the plate in motion!

The magnitude of the force is proportional to the Area, thus we look at $F/A \Rightarrow$ shear stress at the wall

Shear stress is transmitted through the fluid to the lower plate!

Shear stress \equiv momentum flux
For this geometry each layer of fluid exerts the same force on the layer below it! The shear stress is constant, otherwise momentum would accumulate in the interior!

Recall the definition of σ_{ij} : (97)
 $\sigma_{ij} \equiv F/A$ exerted by fluid
of greater i on fluid of
lesser i in j direction!

In this case we have

$$\sigma_{yx} = F/A$$

Which, for this geometry, is constant!

What are the properties of σ_{ij} ?

\Rightarrow The stress tensor is symmetric!

$$\sigma_{ij} = \sigma_{ji}$$

or

$$\underline{\sigma} \approx \underline{\sigma}^T$$

This is really counter intuitive!

In this flow

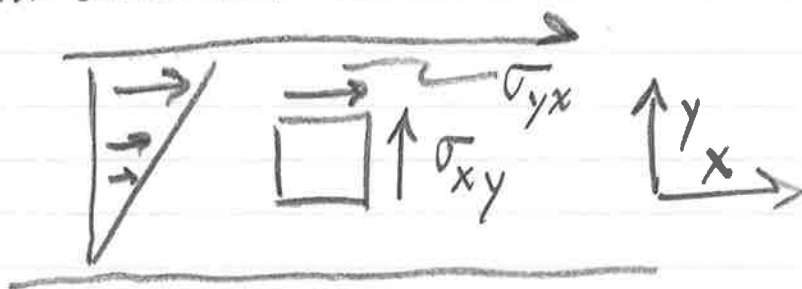

98

$$\sigma_{yx} = \sigma_{xy} ??$$

Let's prove this! Consider a fluid element:

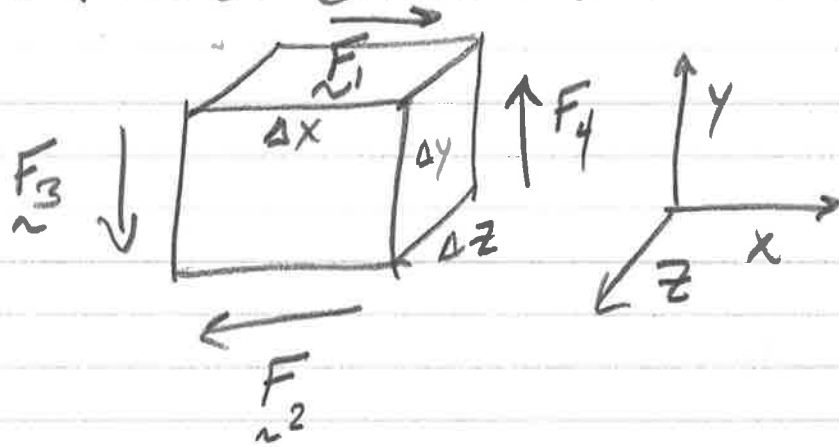

$$\vec{F}_1 \equiv \sigma_{yx} (\Delta z \Delta x) \hat{e}_x$$

$$\vec{F}_2 \equiv -\sigma_{yx} (\Delta z \Delta x) \hat{e}_x$$

$$\vec{F}_3 \equiv -\sigma_{xy} (\Delta z \Delta y) \hat{e}_y$$

$$\vec{F}_4 \equiv \sigma_{xy} (\Delta z \Delta y) \hat{e}_y$$

Now we have $\sum \vec{F} = 0$ because element isn't accelerating

What about the Torque??

$$\begin{aligned}\vec{M} &= \sum \vec{r} \times \vec{F} = -\frac{\Delta y}{2} \sigma_{yx} (\Delta z \Delta x) \hat{e}_z \\ &\quad - \frac{\Delta y}{2} \sigma_{yx} (\Delta z \Delta x) \hat{e}_z + \frac{\Delta x}{2} \sigma_{xy} (\Delta z \Delta y) \hat{e}_z \\ &\quad + \frac{\Delta x}{2} \sigma_{xy} \Delta z \Delta y \hat{e}_z \\ &= \Delta x \Delta y \Delta z \hat{e}_z (\sigma_{xy} - \sigma_{yx})\end{aligned}$$

We have, just like $F = ma$, a relation for the angular acceleration of any object:

$$\frac{d\vec{J}}{dt} = \frac{\vec{M}}{I} \leftarrow \text{moment of inertia}$$

$$I = \int_0 \rho s^2 dV = \frac{\rho x \Delta y \Delta z}{12} \rho (\Delta x^2 + \Delta y^2)$$

↙ distance from axis of rotation

100

Thus:

$$\frac{d\tilde{\Omega}}{dt} = \frac{\tilde{M}}{I} = \frac{12 \hat{e}_z}{\rho} \frac{(\sigma_{xy} - \sigma_{yx})}{(\Delta x^2 + \Delta y^2)}$$

as $\Delta x, \Delta y \rightarrow 0$ any angular acceleration must be finite, thus we conclude $\sigma_{xy} = \sigma_{yx}$!

There is an exception to this: For very weird systems you can get a body torque: torque applied uniformly through a fluid. This would make the stress tensor asymmetric! How can you do this?

If you have an ER (electrorheological) fluid in a rotating electric or magnetic field you get this effect. Don't worry About It: For all

normal systems, the stress tensor ⁽¹⁰¹⁾ is symmetric!!

Another useful property:
For any surface w/ normal \underline{n} , the stress (force/area) exerted by surroundings on fluid is just:

$$\underline{f} = \underline{\sigma} \cdot \underline{n}$$

We can use this in our momentum balance equation!

Recall:

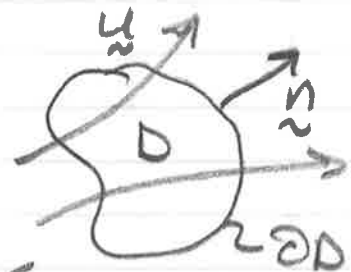

$$\left\{ \begin{array}{l} \text{net momentum out} \\ \text{by convection} \end{array} \right\} + \left\{ \text{Accumulation} \right\} \\ = \left\{ \text{body forces} \right\} + \left\{ \text{surface forces} \right\}$$

So:

$$\int_{\partial D} \rho \underline{u} (\underline{u} \cdot \underline{n}) dA + \int_D \frac{\partial}{\partial t} (\rho \underline{u}) dV$$

$$= \int_D \rho \underline{g} dV + \int_{\partial D} \underline{\sigma} \cdot \underline{n} dA$$

We apply the Divergence theorem:

$$\int_D \underline{\nabla} \cdot (\rho \underline{u} \underline{u}) dV + \int_D \frac{\partial (\rho \underline{u})}{\partial t} dV$$

$$= \int_D \rho \underline{g} dV + \int_D \underline{\nabla} \cdot \underline{\sigma} dV$$

or, since D is arbitrary:

$$\underline{\nabla} \cdot (\rho \underline{u} \underline{u}) + \frac{\partial (\rho \underline{u})}{\partial t}$$

$$= \rho \underline{g} + \underline{\nabla} \cdot \underline{\sigma}$$

We can simplify this by differentiating by parts:

$$\nabla \cdot (\rho \underline{u} \underline{u}) \equiv \rho \underline{u} \cdot \nabla \underline{u} + \underline{u} \nabla \cdot (\rho \underline{u})$$

$$\frac{\partial (\rho \underline{u})}{\partial t} = \underline{u} \frac{\partial \rho}{\partial t} + \rho \frac{\partial \underline{u}}{\partial t}$$

Substituting in:

$$\begin{aligned} \rho \frac{\partial \underline{u}}{\partial t} + \rho \underline{u} \cdot \nabla \underline{u} + \underline{u} \left[\frac{\partial \rho}{\partial t} + \nabla \cdot (\rho \underline{u}) \right] \\ = \nabla \cdot \underline{\underline{\sigma}} + \rho \underline{\underline{g}} \end{aligned}$$

Now from conservation of mass:

$$\frac{\partial \rho}{\partial t} = -\nabla \cdot (\rho \underline{u}) !$$

thus the term in brackets is zero

$$\text{So: } \rho \left[\frac{\partial \underline{u}}{\partial t} + \underline{u} \cdot \nabla \underline{u} \right] = \nabla \cdot \underline{\underline{\sigma}} + \rho \underline{\underline{g}}$$

$$\text{or } \rho \frac{D \underline{u}}{D t} = \nabla \cdot \underline{\underline{\sigma}} + \rho \underline{\underline{g}}$$

We can also write this in index notation:

$$\rho \left(\frac{\partial u_i}{\partial t} + u_j \frac{\partial u_i}{\partial x_j} \right) = \frac{\partial \sigma_{ij}}{\partial x_j} + \rho g_i$$

Note that each term has only one unrepeated index, and that they are all the same!

To proceed, we look at the total stress σ_{ij} . We define:

$$\sigma_{ij} = -p \delta_{ij} + \tau_{ij}$$

where $p = -\frac{1}{3} (\sigma_{11} + \sigma_{22} + \sigma_{33})$

is the pressure - the average of the normal stresses in the three orthogonal directions (well, the negative of this anyway)

Other ways of saying this: (105)

$$p = -\frac{1}{3} \sigma_{ij} \delta_{ij} = -\frac{1}{3} \sigma_{ii}$$

where $\sigma_{ii} = \text{trace}(\underline{\underline{\sigma}})$

τ_{ij} is known as the deviatoric stress and arises due to fluid motion. It is identically zero for isotropic fluids at rest (e.g., hydrostatics)

What are the properties of τ_{ij} ??

\Rightarrow Since σ_{ij} is symmetric, so is τ_{ij}

\Rightarrow By definition τ_{ij} is traceless

e.g.,
$$\tau_{ij} = \sigma_{ij} + p \delta_{ij}$$

$$\therefore \tau_{ij} \delta_{ij} = \sigma_{ij} \delta_{ij} + p \delta_{ij} \delta_{ij}$$

$$\tau_{ii} = \sigma_{ii} + 3p = 0$$

(106)

$\Rightarrow \tau_{ij}$ arises from the deformation of a fluid!

As an example, consider flow between two parallel plates:

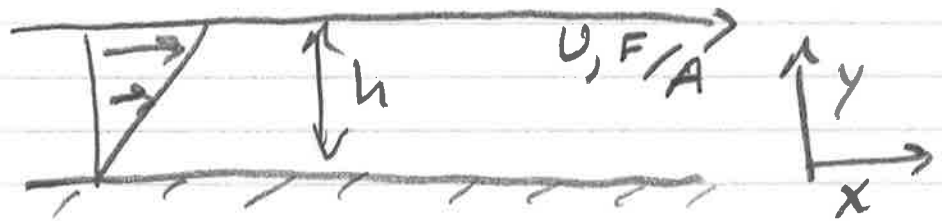

In this geometry, $\tau_{yx} \equiv F/A$
Experimentally, we find:

$$\frac{F}{A} = \mu \frac{U}{h}$$

where μ is the fluid viscosity!

Now we also have:

$$\frac{U}{h} = \frac{d u_x}{d y} \quad (\text{linear profile})$$

Thus we get Newton's Law of Viscosity:

$$\tau_{yx} = \mu \frac{d u_x}{d y}$$

107
We can generalize this a bit!

Remember that $\tilde{\tau}$ is symmetric!

$$\text{Thus } \tau_{yx} = \tau_{xy} = \mu \left(\frac{\partial u_x}{\partial y} + \frac{\partial u_y}{\partial x} \right)$$

Actually, we can generalize this still further. If τ_{ij} is proportional to the rate of strain tensor $\frac{\partial u_i}{\partial x_j}$, we have the general relation:

$$\tau_{ij} = A_{ijkl} \frac{\partial u_k}{\partial x_l}$$

where A_{ijkl} is a fourth order tensor. We have three restrictions on A_{ijkl} . First, if the fluid is isotropic, then A_{ijkl} must also be isotropic (it's a material property).

(108)

Thus:

$$A_{ijkl} = \lambda_1 \delta_{ij} \delta_{kl} + \lambda_2 \delta_{ik} \delta_{jl} + \lambda_3 \delta_{il} \delta_{jk}$$

Second we know that $\underline{\tau}$ is symmetric, e.g. that $\tau_{ij} = \tau_{ji}$

This requires: $A_{ijkl} = A_{jickl}$

or that $\lambda_2 = \lambda_3$

Finally, we know that $\underline{\tau}$ is traceless, e.g. that $\tau_{ij} \delta_{ij} = 0$

This requires $\delta_{ij} A_{ijkl} = 0$

Plugging this in, we get $\lambda_1 = -\frac{2}{3} \lambda_2$

Thus:

$$A_{ijkl} \equiv \lambda_2 \left[\delta_{ik} \delta_{jl} + \delta_{il} \delta_{jk} - \frac{2}{3} \delta_{ij} \delta_{kl} \right]$$

or, as it's usually written:

(109)

$$\tau_{ij} = \mu \left(\frac{\partial u_i}{\partial x_j} + \frac{\partial u_j}{\partial x_i} - \frac{2}{3} \delta_{ij} \nabla \cdot \underline{u} \right)$$

So we see that this complex expression for the shear stress arises naturally from the assumptions of linearity, isotropy, and the definition of the pressure ($\tau_{ii} = 0$).

For more complex fluids the stress-strain relation is alot messier! The study of such relations is the field of rheology.

For an incompressible fluid

$\nabla \cdot \underline{u} \equiv 0$, thus:

$$\tau_{ij} = \mu \left(\frac{\partial u_i}{\partial x_j} + \frac{\partial u_j}{\partial x_i} \right)$$

We can plug this in:

$$\rho \left(\frac{\partial u_i}{\partial t} + u_j \frac{\partial u_i}{\partial x_j} \right) = \frac{\partial \tau_{ij}}{\partial x_j} + \rho g_i$$

$$\tau_{ij} = -P \delta_{ij} + \tau_{ij}$$

Thus:

$$\rho \left(\frac{\partial u_i}{\partial t} + u_j \frac{\partial u_i}{\partial x_j} \right) = -\frac{\partial P}{\partial x_i} + \frac{\partial \tau_{ij}}{\partial x_j} + \rho g_i$$

but: (for incompressible fluids)

$$\frac{\partial \tau_{ij}}{\partial x_j} = \mu \frac{\partial}{\partial x_j} \left(\frac{\partial u_i}{\partial x_j} + \frac{\partial u_j}{\partial x_i} \right)$$

$$= \mu \left[\frac{\partial^2 u_i}{\partial x_j^2} + \frac{\partial}{\partial x_i} \frac{\partial u_j}{\partial x_j} \right]$$

assume μ is constant

So:

$$\rho \left(\frac{\partial u_i}{\partial t} + u_j \frac{\partial u_i}{\partial x_j} \right) = -\frac{\partial P}{\partial x_i} + \mu \frac{\partial^2 u_i}{\partial x_j^2} + \rho g_i$$

or

$$\rho \left(\frac{\partial \underline{u}}{\partial t} + \underline{u} \cdot \nabla \underline{u} \right) = -\nabla P + \mu \nabla^2 \underline{u} + \rho \underline{g}$$

which are known as the Navier-Stokes equations. They are valid for

in compressible Newtonian fluids ^(III) with constant viscosity (or at least not a function of position!).

If any of these assumptions are not valid, the equations need to be modified! Fortunately, they work for most chem. eng. problems!

Let's look at the equation term by term:

$\rho \frac{\partial \underline{u}}{\partial t} \Rightarrow$ time dependent accumulation of momentum

$\rho \underline{u} \cdot \nabla \underline{u} \Rightarrow$ Convection of momentum, associated with fluid inertia

$-\nabla P \Rightarrow$ Gradients in the pressure act as a source or sink of momentum

$\mu \nabla^2 \underline{u} \Rightarrow$ Viscous diffusion of momentum

(112)

$g \Rightarrow$ Gravitational (body force)
 \sim source of momentum

Try to build up a physical picture
of each of the physical mechanisms
behind these terms! Such an
understanding will help you determine
which terms are important in any
physical problem!

OK, now let's apply these equations
to the simplest flow problem:

Plane Couette Flow



We assume an incompressible, Newtonian
fluid with constant viscosity, thus

we have the equations:

$$\nabla \cdot \underline{u} = 0$$

$$\rho \left(\frac{\partial \underline{u}}{\partial t} + \underline{u} \cdot \nabla \underline{u} \right) = -\nabla P + \mu \nabla^2 \underline{u} + \rho \underline{g}$$

We also need boundary conditions

$$\underline{u} \Big|_{y=0} = 0 \quad (\text{all 3 components})$$

$$\underline{u} \Big|_{y=h} = U_0 \hat{e}_x \quad (y \text{ \& } z \text{ components are zero})$$

Now we start throwing out terms.

We anticipate that the flow is only in the x -direction, thus

$$u_y = u_z = 0$$

From continuity:

$$\frac{\partial u_x}{\partial x} + \frac{\partial u_y}{\partial y} + \frac{\partial u_z}{\partial z} = 0$$

\downarrow \downarrow
 0 0

(114)

Thus $\frac{\partial u_x}{\partial x} = 0$

\Rightarrow There is no change in the velocity in the flow direction for unidirectional flow.

\Rightarrow The converse: If the velocity changes in the flow direction, then it cannot be uni-directional! (e.g., if $\frac{\partial u_x}{\partial x} \neq 0$ then u_y or u_z must be non-zero somewhere!)

We assume that the flow is 2-D (no change in z -direction), thus $\frac{\partial}{\partial z} = 0$

We assume that there are no applied pressure gradients,

thus $\frac{\partial P}{\partial x} = 0$

We take $\underline{g} = -g \hat{e}_y$
(not in x-direction)

We assume flow is at steady-state, so $\frac{\partial}{\partial t} = 0$

Ok, what's left??

C.E.:

$$\frac{\partial u_x}{\partial x} + \frac{\partial u_y}{\partial y} + \frac{\partial u_z}{\partial z} = 0$$

so $\frac{\partial u_x}{\partial x} = 0$

z-momentum:

$$\rho \left(\frac{\partial u_z}{\partial t} + u_x \frac{\partial u_z}{\partial x} + u_y \frac{\partial u_z}{\partial y} + u_z \frac{\partial u_z}{\partial z} \right) = -\frac{\partial p}{\partial z} + \mu \nabla^2 u_z + \rho g_z$$

so $\frac{\partial p}{\partial z} = 0$ (no pressure gradient in z-direction)

y-momentum:

$$\rho \left[\frac{\partial u_y}{\partial t} + u_x \frac{\partial u_y}{\partial x} + u_y \frac{\partial u_y}{\partial y} + u_z \frac{\partial u_y}{\partial z} \right]$$

$$= -\frac{\partial p}{\partial y} + \mu \nabla^2 u_y + \rho g_y$$

$$\text{so } \frac{\partial p}{\partial y} = \rho g_y \equiv -\rho g$$

Hence $P = f(x) - \rho g y$

↳ actually, will be a cst since no gradient is applied in x-direction

Just by hydrostatic pressure variation!

Now for x-momentum (this is the important one, because the flow is in the x-direction!)

(117)

$$\rho \left[\frac{\partial u_x}{\partial t} + u_x \frac{\partial u_x}{\partial x} + u_y \frac{\partial u_x}{\partial y} + u_z \frac{\partial u_x}{\partial z} \right]$$

$$= -\frac{\partial p}{\partial x} + \mu \left[\frac{\partial^2 u_x}{\partial x^2} + \frac{\partial^2 u_x}{\partial y^2} + \frac{\partial^2 u_x}{\partial z^2} \right] + \rho g_x$$

What survives? u_y & $u_z = \underline{\underline{0}}$,
 so those convective terms are
zero!

System is at S.S., so $\frac{\partial u_x}{\partial t} = 0$

From C.E. $\frac{\partial u_x}{\partial x} = 0$, so $u_x \frac{\partial u_x}{\partial x} = 0$,
 likewise $\frac{\partial^2 u_x}{\partial x^2} = 0$ (on RHS)

No variation in z -direction, so

$$\frac{\partial^2 u_x}{\partial z^2} = 0$$

No gravity in x -direction, so

$$\rho g_x = 0$$

(118)

No pressure gradient (applied)
in x-direction, so

$$-\frac{\partial P}{\partial x} = 0$$

What's left?

$$\frac{\partial^2 u_x}{\partial y^2} = 0, \quad u_x \Big|_{y=0} = 0$$

$$u_x \Big|_{y=h} = U_0$$

This is easily solved - just integrate twice!

$$u_x = Ay + B$$

$$u_x \Big|_{y=0} = 0 \quad \therefore B = 0$$

$$u_x \Big|_{y=h} = U_0 \quad \therefore A = \frac{U_0}{h}$$

$$\text{and } u_x = U_0 \frac{y}{h}$$

This is called simple shear ⁽¹¹⁹⁾
flow or plane Couette flow.
It's used to study the rheology
of fluids, and is usually produced
in the narrow gap between concentric
rotating cylinders:

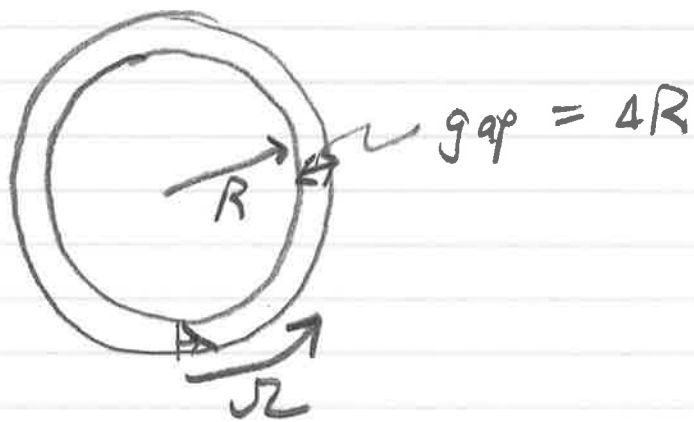

By rotating the outer cylinder you
deform the fluid in the gap and
exert a torque on the inner
cylinder. This torque is used
to calculate the viscosity!

What's this relationship??

120

\Rightarrow if $\frac{\Delta R}{R} \ll 1$ we can ignore curvature effects:



$$\text{Thus } u_x \approx U_0 \frac{y}{\Delta R}$$

The stress on the inner cylinder

is:

$$\tau_{yx} = \mu \frac{\partial u_x}{\partial y} \approx \frac{\mu U_0}{\Delta R}$$

The torque is:

$$M \approx (\tau_{yx})(R)(2\pi R H)$$

where H is the height in the z -direction. Thus:

$$M \approx \mu 2\pi \frac{\Omega R^3 H}{\Delta R} \quad \text{for } \frac{\Delta R}{R} \ll 1$$

which can be used to estimate μ

Another example: Flow down
an inclined plane

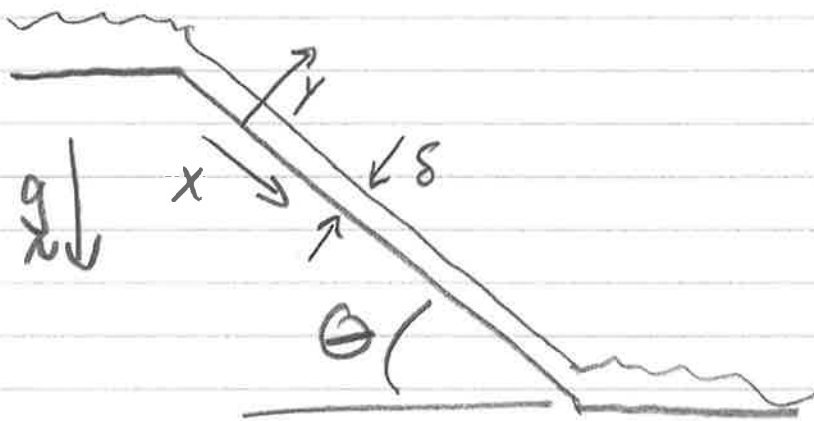

If the fluid is viscous, it will rapidly reach some constant thickness δ , and some steady velocity profile. What is the relationship between Q/W , u , δ , ρ , μ , g , and θ ?? Just apply the Navier-Stokes equations!

First we choose a coordinate system aligned with the geometry!

Let x be the direction along the plate, and y be normal to the plate w/ $y=0$ at the plate:

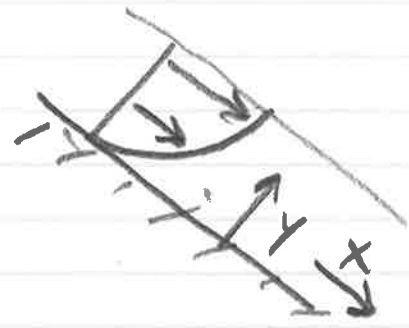

Thus $\vec{g} = -g \cos \theta \hat{e}_y + g \sin \theta \hat{e}_x$
Again, we have unidirectional flow in the x -direction. We expect there will be no flow in the y -direction - just a hydrostatic pressure variation.

Note: to solve these sorts of problems, look at it physically & keep those terms which appear to

important, crossing out those ⁽¹²³⁾ you expect to be zero. If you can satisfy all B.C.'s with the simplified equation, you got it right! This is strictly true only for linear problems, as non-linear equations often have multiple solutions! Even there, it's a good way to start.

Know Each Term Physically

OK, we expect unidirectional flow.

Thus:

$$0 = -\frac{\partial P}{\partial y} + \rho g_y$$

$$0 = -\frac{\partial P}{\partial x} + \mu \nabla^2 u_x + \rho g_x$$

Recall that for unidirectional incompressible flow

$$\frac{\partial u_x}{\partial x} = 0$$

There is no variation in the z-direction (2-D flow), thus

$$\nabla^2 u_x = \frac{\partial^2 u_x}{\partial y^2}$$

Now to solve: First we get the pressure distribution.

$$f_y = -g \cos \theta$$

$$\therefore P = f(x) - \rho g y \cos \theta$$

but $P|_{y=0} = P_0$ (atmospheric)

Thus
$$P = P_0 + \rho g (0 - y) \cos \theta$$

Note that $\frac{\partial P}{\partial x} = 0$ so ¹²⁵ it disappears from the x-momentum equation!

$$0 = -\cancel{\frac{\partial P}{\partial x}} + \mu \frac{\partial^2 u_x}{\partial y^2} + \rho g \sin \theta$$

$$\text{so } \frac{\partial^2 u_x}{\partial y^2} = -\frac{\rho g}{\mu} \sin \theta$$

Integrating:

$$u_x = -\frac{1}{2} y^2 \frac{\rho g}{\mu} \sin \theta + Ay + B$$

We now determine the unknown constants from the B.C.'s. What are they??

1) No-slip condition at $y=0$!

plate isn't moving at $y=0$, so neither is the fluid!

(126)

$$u_x|_{y=0} = 0$$

Thus $B \equiv 0$

2) at $y = \delta$ the shear stress is zero! The gas (air) over the fluid doesn't exert any stress on it, so

$$\tau_{yx}|_{y=\delta} = \mu \left. \frac{\partial u_x}{\partial y} \right|_{y=\delta} = 0$$

$$\text{So } A = + \frac{\rho g \delta}{\mu} \sin \theta$$

Thus:

$$u_x = \frac{\rho g \delta^2}{\mu} \sin \theta \left(\frac{y}{\delta} - \frac{1}{2} \left(\frac{y}{\delta} \right)^2 \right)$$

From this we see that u_x varies as δ^2 , and at $y = \delta$ we have a maximum $(u_x)_{\max} = \frac{1}{2} \frac{\rho g \delta^2}{\mu} \sin \theta$

We also want to look at 127
the total flow rate:

$$\begin{aligned} Q &= \int_A \underline{u} \cdot \underline{n} \, dA \\ &= w \int_0^\delta u_x \, dy \\ &= \frac{w \rho g \delta^3}{\mu} \sin \theta \left[\frac{1}{2} - \frac{1}{6} \right] \\ &= \frac{1}{3} \frac{w \rho g \delta^3}{\mu} \sin \theta \end{aligned}$$

So Q varies as δ^3 . If we knew Q (or Q/w), this relation would give us δ .

This equation will not hold if δ is too large (or μ too small), what happens is the flow field becomes unstable and ripples form!

This is an example of the ⁽¹²⁸⁾ effect of non-linearities! There are multiple solutions to the full equations where $u_y \neq 0$, and where u_x and u_y are functions of time. Such waves have been extensively studied over the past 30 years! In our department Chang is perhaps the leading expert on falling films, while McCready is the leading expert on instabilities in cocurrent gas-liquid flows where the gas exerts some stress on the interface ($\tau_{yx}|_s \neq 0$). These two areas are important in coating flows and pipeline flows.

Another example: Flow through a pipe!



Suppose we have an axial pressure gradient (e.g., $\frac{\partial P}{\partial z} \neq 0$)

What is the flow profile?

For a given μ , $\frac{\Delta P}{L}$, R what is the flow rate? Again we

choose a coordinate system aligned with the boundary:
Cylindrical coordinates!

Let's solve this: We begin with the C.E.:

$$\nabla \cdot \underline{u} = 0 \equiv \frac{1}{r} \frac{\partial}{\partial r} (r u_r) + \frac{1}{r} \frac{\partial u_\theta}{\partial \theta} + \frac{\partial u_z}{\partial z} = 0$$

For uni-directional flow in the z-direction, $u_r = u_\theta = 0$

Thus $\frac{\partial u_z}{\partial z} = 0$

The assumption of unidirectional flow will limit the applicability of our solution! We'll see how this works later!

OK, now we solve for the velocity distribution. We focus on the z-momentum eq'n in cylindrical coord:

$$\rho \left(\underbrace{\frac{\partial u_z}{\partial t}}_{0 \text{ (SS)}} + \underbrace{u_r \frac{\partial u_z}{\partial r}}_0 + \underbrace{\frac{u_\theta}{r} \frac{\partial u_z}{\partial \theta}}_0 + \underbrace{u_z \frac{\partial u_z}{\partial z}}_{0 \text{ (CE)}} \right) = -\frac{\partial p}{\partial z} + \mu \left[\underbrace{\frac{1}{r} \frac{\partial}{\partial r} \left(r \frac{\partial u_z}{\partial r} \right)}_{0 \text{ (symmetry)}} + \underbrace{\frac{1}{r^2} \frac{\partial^2 u_z}{\partial \theta^2}}_{0 \text{ (CE)}} + \underbrace{\frac{\partial^2 u_z}{\partial z^2}}_{0 \text{ (CE)}} \right] + \rho g_z$$

(131)

So:

$$\mu \frac{1}{r} \frac{\partial}{\partial r} \left(r \frac{\partial u_z}{\partial r} \right) = \frac{\partial P}{\partial z} - \rho g_z$$

Note that there are two possible sources for momentum: pressure gradients or gravity. Both act in exactly the same way! Both (if constant) are uniform sources (or sinks) of momentum in the fluid! Here we take $g_z = 0$ and look at the pressure gradient

$$\text{Let } \frac{\partial P}{\partial z} \equiv \frac{\Delta P}{L} \quad (\text{pressure drop/length})$$

(note: this is negative!)

$$\text{So } \frac{1}{r} \frac{\partial}{\partial r} \left(r \frac{\partial u_z}{\partial r} \right) = \frac{1}{\mu} \frac{\Delta P}{L} \equiv \underline{\text{cst}}$$

We integrate once:

(mult. both sides by r before ⁽¹³²⁾ integ.):

$$r \frac{du_z}{dr} = \frac{1}{2} r^2 \frac{1}{\mu} \frac{\Delta P}{L} + A$$

$$\frac{du_z}{dr} = \frac{1}{2} r \frac{1}{\mu} \frac{\Delta P}{L} + \frac{A}{r}$$

$$u_z = \frac{1}{4} r^2 \frac{1}{\mu} \frac{\Delta P}{L} + A \ln r + B$$

Now at $r=0$ u_z must be finite,

thus: $A \equiv 0$

At $r=R$ $u_z = 0$ (no-slip),

thus:

$$B = -\frac{1}{4} R^2 \frac{1}{\mu} \frac{\Delta P}{L}$$

$$\text{or } u_z = -\frac{1}{4} \frac{R^2}{\mu} \frac{\Delta P}{L} \left(1 - \frac{r^2}{R^2}\right)$$

which is a parabola again!

Gravity would yield the same result,

just replace $-\frac{\Delta P}{L}$ with ρg_z !

What is the total flow rate 133

$$Q = \int_A u_z dA = \int_0^R 2\pi u_z r dr$$

since it's not a $f^n(\theta)$

Integrating:

$$Q = 2\pi \left(\frac{-1}{4} \frac{\Delta P}{L} \frac{R^2}{\mu} \right) R^2 \int_0^1 (1-r^{*2}) r^* dr^*$$

where $r^* = \frac{r}{R}$

So:

$$Q = \frac{-\pi}{8} \frac{\Delta P}{L} \frac{R^4}{\mu}$$

which is known as Poiseuille's Law
& flow thru a tube is also called
Poiseuille flow.

OK, what is it good for? It is the
basis of the capillary viscometer.

$$\mu = \left(\frac{-\Delta P}{L} \right) \frac{\pi}{8} \frac{R^4}{Q}$$

Usually, the ΔP is provided by hydrostatic pressure variation: just measure time for fluid to fall between two lines! It's an easily calibrated instrument.

What are the limitations on Poiseuille's Law? \Rightarrow Assumption of unidirectional flow!

There are two ways this is violated: entrance effects & turbulence

Look at turbulence first: If flow is too fast, becomes unstable!

Reynolds showed that for a tube the transition is governed by a

Dimensionless Number

$$Re = \frac{UD}{\nu}$$

Physically, this represents the ratio of inertial forces to viscous forces.
 \Rightarrow An alternative interpretation is in terms of characteristic times:
 Recall that momentum can move either by convection or diffusion (e.g., the kinematic viscosity). Then Re is the ratio of the diffusion time to the convection time:

$$Re = \frac{(D^2/\nu)}{(D/U)} = \frac{UD}{\nu}$$

Reynolds found flow to be unstable for $\frac{UD}{\nu} \gtrsim 2100$ for tubes. You get different values of Re_{cr} for different geometries.

136
OK, what about entrance length effects? \Rightarrow Initially, entering flow profile is (more or less) flat, & must evolve to parabolic shape. How far down the tube does this take?

The flow evolves due to diffusion of momentum, so:

$$t_D \sim \frac{R^2}{\nu} \quad \leftarrow \begin{array}{l} \text{distance over} \\ \text{which diffusion} \\ \text{takes place} \end{array}$$

How far does it move during t_D ?

$$L \sim t_D U \sim \frac{UR^2}{\nu} \equiv \frac{1}{4} D \frac{UD}{\nu}$$

Actually, the entrance length is usually

given as:

$$L_e = 0.035 D \frac{UD}{\nu}$$

which is just a bit numerically smaller!

Let's look at another problem 137
in Cylindrical Coordinates!

Couette flow!

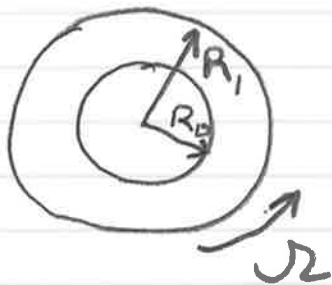

we again use the r, θ, z coord. system. This time, however, the velocity is in the θ direction!

$$\nabla \cdot \underline{u} = 0 = \frac{1}{r} \frac{\partial}{\partial r} (r u_r) + \frac{1}{r} \frac{\partial u_\theta}{\partial \theta} + \frac{\partial u_z}{\partial z}$$

Thus if $u_r = u_z = 0$ then $\frac{\partial u_\theta}{\partial \theta} = 0$

(no variation in θ direction)

Now for the momentum equations:

\Rightarrow we looked at z -momentum last time,
now look at r & θ components!

r -momentum:

$$\rho \left(\frac{\partial u_r}{\partial t} + u_r \frac{\partial u_r}{\partial r} + \frac{u_\theta}{r} \frac{\partial u_r}{\partial \theta} - \frac{u_\theta^2}{r} + u_z \frac{\partial u_r}{\partial z} \right)$$

$$= -\frac{\partial P}{\partial r} + \rho g_r + \mu \left[\frac{\partial}{\partial r} \left(\frac{1}{r} \frac{\partial}{\partial r} (r u_r) \right) \right.$$

$$\left. + \frac{1}{r^2} \frac{\partial^2 u_r}{\partial \theta^2} - \frac{2}{r^2} \frac{\partial u_\theta}{\partial \theta} + \frac{\partial^2 u_r}{\partial z^2} \right]$$

Now if $g_r = 0$, $u_r = u_z = 0$ and $\frac{\partial u_\theta}{\partial \theta} = 0$
we're left with:

$$-\rho \frac{u_\theta^2}{r} = -\frac{\partial P}{\partial r}$$

↑
centrifugal force term! It is a "pseudo force" which arises from the coordinate transformation!

Thus $P = f(\theta, z) + \int \rho \frac{u_\theta^2}{r} dr$
which can be integrated if you know $u_\theta(r)$!

OK, let's look at the θ component 139
 (where the action is!)

$$\begin{aligned} & \rho \left(\frac{\partial u_\theta}{\partial t} + u_r \frac{\partial u_\theta}{\partial r} + \frac{u_\theta}{r} \frac{\partial u_\theta}{\partial \theta} + \frac{u_r u_\theta}{r} + u_z \frac{\partial u_\theta}{\partial z} \right) \\ &= -\frac{1}{r} \frac{\partial P}{\partial \theta} + \rho g_\theta + \mu \left[\frac{\partial}{\partial r} \left(\frac{1}{r} \frac{\partial}{\partial r} (r u_\theta) \right) \right. \\ & \quad \left. + \frac{1}{r^2} \frac{\partial^2 u_\theta}{\partial \theta^2} + \frac{2}{r^2} \frac{\partial u_\theta}{\partial \theta} + \frac{\partial^2 u_\theta}{\partial z^2} \right] \end{aligned}$$

OK, most of these terms are zero too! Let's look at one that pops up due to the coordinate transformation:

$$\rho \frac{u_r u_\theta}{r}$$

This is the Coriolis force. It is very important in large scale (e.g., high Re) rotating systems!

The most important example is the weather! It's why the wind direction

is perpendicular to pressure
gradients! (140)

To see why this occurs, consider
a disk undergoing solid body rotation:

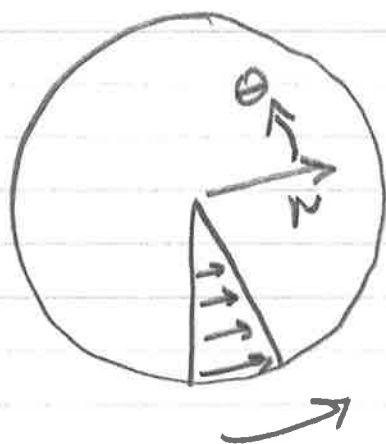

Now $u_\theta = \Omega r$ for solid body rotation.
The local angular velocity is constant.
If fluid is displaced inwards, then
if u_θ is conserved (say, conservation
of kinetic energy) the local rate
of rotation $\Omega' = \frac{u_\theta}{r - \Delta r} > \Omega$. In
the rotating reference frame, it looks
like it's going faster!

On the earth, rotational velocities ⁽¹⁴¹⁾ are much higher than wind velocities, at least on large length scales, thus the Coriolis force is dominant

$$\omega R \sim \frac{2\pi}{24 \text{ hr}} \cdot 4,000 \text{ m} \sim \underline{10^3 \text{ mph!}}$$

On lab length scales it's small (at least due to earth rotation) \Rightarrow the bathtub vortex is due to some initial swirling motion!

OK, how about Couette flow?
 $u_r = 0$ so Coriolis force doesn't matter!

$\frac{\partial P}{\partial \theta} = 0$ from symmetry, so:

$$0 = \mu \frac{\partial}{\partial r} \left(\frac{1}{r} \frac{\partial}{\partial r} (r u_\theta) \right)$$

142

we integrate this once:

$$\frac{1}{r} \frac{d}{dr} (r u_\theta) = C_1$$

And a second time:

$$r u_\theta = \frac{1}{2} C_1 r^2 + C_2$$

$$\text{or: } u_\theta = \frac{1}{2} C_1 r + \frac{C_2}{r}$$

We have the no-slip B.C.'s:

$$u_\theta = \begin{cases} 0 & r = R_0 \\ \Omega R_1 & r = R_1 \end{cases}$$

Thus:

$$\frac{1}{2} C_1 R_0 + \frac{C_2}{R_0} = 0$$

$$\frac{1}{2} C_1 R_1 + \frac{C_2}{R_1} = \Omega R_1$$

$$\text{So: } C_1 = \frac{-2C_2}{R_0^2}; \quad C_2 = -\Omega \left(\frac{R_1^2 R_0^2}{R_1^2 - R_0^2} \right)$$

and:

$$u_\theta = \Omega R_1 \left(\frac{R_1 R_0}{R_1^2 - R_0^2} \right) \left(\frac{r^2 - R_0^2}{R_0 r} \right)$$

(143)

We wish to calculate the torque on the inner cylinder. We have:

$$\vec{M} = \vec{r} \times \vec{F}$$

Now the force F is just the shear stress $\tau_{r\theta}$ times the area of the cylinder. Recall $\tau_{r\theta} \equiv F/A$ exerted by fluid of greater r on fluid of lesser r in the θ direction!

So:

$$\vec{M} = \vec{r} \cdot \underbrace{2\pi r h}_{\text{Area}} \tau_{r\theta} \hat{e}_z$$

lever arm

In cylindrical coordinates:

$$\tau_{r\theta} = \mu \left[r \frac{\partial}{\partial r} \left(\frac{u_\theta}{r} \right) + \frac{1}{r} \frac{\partial u_r}{\partial \theta} \right]$$

Now $u_r = 0$ and u_θ is given (144)

$$\text{by: } \frac{u_\theta}{\omega} = \frac{\sqrt{2} R_1^2}{R_1^2 - R_0^2} \left(1 - \frac{R_0^2}{r^2} \right)$$

$$\text{So: } \tau_{r\theta} = 2\mu \frac{\sqrt{2} R_1^2}{R_1^2 - R_0^2} \frac{R_0^2}{r^2}$$

and hence the torque:

$$\underline{M} = 4\pi\mu h \Omega \frac{R_1^2 R_0^2}{R_1^2 - R_0^2} \underline{e}_z$$

Note that this is independent of ω ! This makes sense: the torque exerted by the outer cylinder is the same as that exerted on the inner cylinder, and every cylindrical surface in between. Otherwise the flow would be accelerating (not at steady-state)!

OK, what about the thin-gap approximation? Just as the earth looks flat when viewed on a human length scale, so fluid mechanics problems may be simplified when characteristic lengths (e.g. the gap width between cylinders) is much smaller than the radius of curvature!

We take $\frac{R_1 - R_0}{R_1} \ll 1$

Locally, we define coordinates:

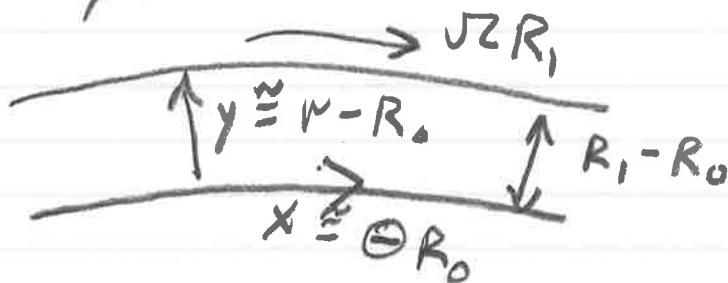

The force F is approximately:

$$F \approx \tau_{yx} \cdot 2\pi R_0 h$$

where:

$$\gamma_{yx} \approx \mu \frac{\Omega R_1}{R_1 - R_0}$$

So:

$$\left(\frac{M}{z}\right)_{\text{approx}} = \mu \frac{\Omega R_1}{R_1 - R_0} R_0 2\pi R_0 h \hat{e}_z$$

We can compare this to the exact result:

$$\frac{\left(\frac{M}{z}\right)_{\text{approx}}}{\left(\frac{M}{z}\right)_{\text{exact}}} = \frac{1}{2} \frac{R_1^2 - R_0^2}{R_1(R_1 - R_0)} = 1 - \frac{1}{2} \frac{R_1 - R_0}{R_1}$$

So if R_0 is 1" and $R_1 - R_0 = 0.02$ " (about 500 μm), then the error is only around 1%!

In this derivation we have assumed that $u_r = u_z = 0$. This will be valid provided the rotation rate is sufficiently small. At higher

(147)

rotation rates the flow becomes unstable, yielding what are called Taylor-Couette vortices.

To see why, remember the centrifugal force term in the r -momentum eqⁿ: $\rho \frac{u_\theta^2}{r}$

Because u_θ is higher inside (smaller r) than outside (larger r), the fluid inside "wants" to flow out while that outside "wants" to flow in. This produces the vortex pattern:

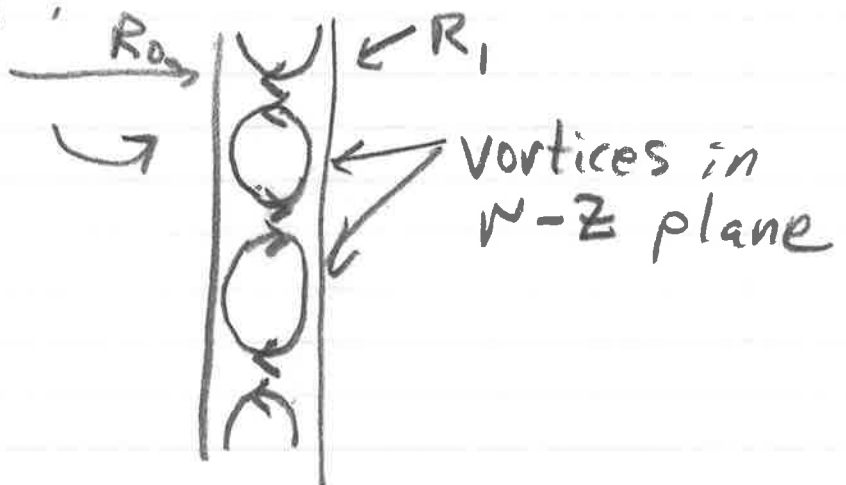

The critical rotation speed at which vortices appear is given by:

$$Ta_{cr} = \frac{\Omega_{cr}^2 R \Delta R^3}{\nu^2} = 1712 \quad \text{for } \frac{\Delta R}{R} \ll 1$$

This phenomenon was first demonstrated by G.I. Taylor in 1923.

Note that if Ω is further increased, these vortices will themselves become unstable to other secondary flows - they become wavy in the θ direction. Eventually the entire flow becomes turbulent.

Taylor-Couette flow is still actively studied today!

Dimensional Analysis (149)

Now that we're familiar w/ the Navier-Stokes equations, let's use them to look at a more complex, general problem: Uniform Flow past an arbitrary shape:

$$\underline{u} = U \hat{e}_x$$

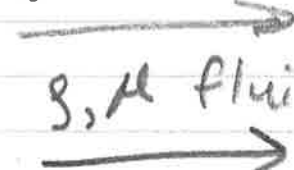

ρ, μ fluid properties

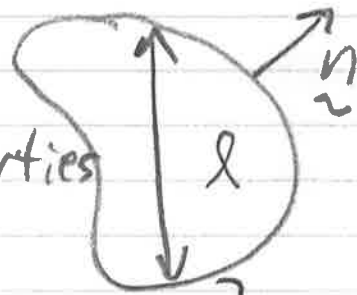

$P \rightarrow P_0$ as $|\underline{x}| \rightarrow \infty$
(far away)

What is the drag (force) on the object??

The force exerted by the fluid on the object is:

$$\underline{F} = \int_{\partial D} \underline{\sigma} \cdot \underline{n} \, dA$$

(150)

where

$$\tau_{ij} \equiv -p \delta_{ij} + \mu \left(\frac{\partial u_i}{\partial x_j} + \frac{\partial u_j}{\partial x_i} \right)$$

for an incompressible Newtonian fluid!

Thus, to calculate the force, we need the stress, and to get that we need u and p! We thus have to solve the N-S eq'n's, which is very difficult for a complex geometry!

⇒ Suppose that, instead, we wish to do it experimentally, using a scale model system. How would this work? Effectively we are "solving" the equations using a

"mechanical computer" - if ⁽¹⁵¹⁾ the assumptions used in deriving the equations are valid, the experiment should match the solution to the N-S eq'ns!

To work with a scale model (& interpret the results), we have to render the problem dimensionless w/ appropriate length & time scales.

* All dimensionless variables should be $O(1)$ in the region of interest! The relative importance

OK, let's see how this works:

We have the Continuity Eq'n
& the N-S eq'ns:

152

$$\nabla \cdot \underline{u} = 0 \quad (\text{incompressible})$$

$$\rho \left[\frac{\partial \underline{u}}{\partial t} + \underline{u} \cdot \nabla \underline{u} \right] = -\nabla P + \mu \nabla^2 \underline{u} + \rho \underline{g}$$

(Newtonian fluid)

Let's choose U as the velocity scaling, ℓ as the length scale,

ℓ/U as the time scale, and

ΔP_c as the pressure scale (to be determined)

Thus:

$$\underline{u}^* = \frac{\underline{u}}{U}, \quad \underline{x}^* = \frac{\underline{x}}{\ell}, \quad \nabla^* = \ell \nabla,$$

$$P^* = \frac{P - P_0}{\Delta P_c} \leftarrow \text{subtract off far-field pressure}$$

$$\underline{g}^* = \frac{\underline{g}}{g} \quad (\text{vector in gravity direction})$$

OK, now we render this problem ⁽¹⁵³⁾ dimensionless:

$$\frac{U}{L} \nabla^* \cdot \underline{u}^* = 0$$

$$\therefore \nabla^* \cdot \underline{u}^* = 0 \quad (\text{unchanged})$$

$$\rho \left[\frac{U}{L} \frac{\partial \underline{u}^*}{\partial t^*} + \frac{U^2}{L} \underline{u}^* \cdot \nabla^* \underline{u}^* \right]$$

$$= - \frac{\Delta P_c}{L} \nabla^* p^* + \mu \frac{U}{L^2} \nabla^{*2} \underline{u}^* + \rho \underline{g}^*$$

Now we divide through by one of these terms to make the problem dimensionless. Which one? Pick a term representing a physical mechanism you're pretty sure is important!

\Rightarrow At high velocities the inertial terms are likely to be important so:

154

Divide by $\frac{\rho U^2}{l}$:

$$\frac{\partial \underline{u}^*}{\partial t^*} + \underline{u}^* \cdot \nabla^* \underline{u}^* = \frac{-\Delta P_c}{\rho U^2} \nabla^* p^* + \frac{\mu}{\rho U l} \nabla^{*2} \underline{u}^* + \frac{g l}{U^2} \underline{g}^*$$

At high velocities pressure gradients arise from inertial effects (e.g., convection of momentum), so we choose:

$$\frac{\Delta P_c}{\rho U^2} = 1$$

or $\Delta P_c = \rho U^2$ as the characteristic pressure differential!

Note that we have two dimensionless groups of parameters in the equations! The magnitude of these groups determine the relative importance

of the dimensionless terms they multiply and the corresponding physical mechanisms!

What are they?

$$\frac{\mu}{\rho U L} \equiv \frac{1}{Re} = \frac{\text{viscous forces}}{\text{inertial forces}}$$

If $Re \gg 1$ then viscous forces are unimportant on a length scale L comparable to the size of the body! We'll see later that they are important in boundary layers next to the body of thickness δ because without viscosity, you can't satisfy the no-slip condition!

156

$$\frac{gL}{U^2} = \frac{1}{Fr}$$

$$Fr \equiv \text{Froude} \# = \frac{\text{Inertia}}{\text{Gravity}}$$

This plays a role in free surface flows, such as the wake behind a ship (or a bow wave).

We also render the boundary conditions dimensionless:

$$\underline{u} \Big|_{|\underline{x}| \rightarrow \infty} = U \hat{e}_x$$

$$\text{So } \underline{u}^* \Big|_{|\underline{x}^*| \rightarrow \infty} = \hat{e}_x$$

$$\underline{u} \Big|_{\partial \Omega} = 0 \quad \text{so} \quad \underline{u}^* \Big|_{\partial \Omega^*} = 0$$

(157)

Sometimes you get additional dimensionless groups from B.C.'s, say if object is rotating.

Here there are only two dimensionless groups which contain all the dimensional information! If these are held constant between the model & the full size system, the dimensionless flow will be exactly the same!!

This is known as dynamic similarity!

OK, how could we use this?

Suppose we want to model a submarine with a $1/100$ scale model, preserving dynamic similarity.

(158)

If there's no free surface, Fr doesn't matter, so we just have to keep Re cst. Let $L_1 =$ length of sub, $L_2 =$ length of model

For dynamic similarity, $Re_1 = Re_2$

$$\text{so: } \frac{U_1 L_1}{\nu_1} = \frac{U_2 L_2}{\nu_2}$$

If both experiments are in water, then $\nu_1 = \nu_2$

$$\text{so: } \frac{U_2}{U_1} = \frac{L_1}{L_2}$$

$$\text{or } U_2 = U_1 \left(\frac{L_1}{L_2} \right) \equiv U_1 \left(\frac{100}{1} \right)$$

Note that this is really hard!

if $U_1 = 40$ mph, $U_2 = 4,000$ mph!

Note that even if we could get

the model up to this speed, ¹⁵⁹ it
still wouldn't achieve similarity!
Our assumptions break down
because $U_2/U_1 \ll 1$ (e.g.,
the Mach # isn't small) and so
the fluid is compressible.

It can work well, however—
suppose we want to look at the
flow patterns in a big tank of
Karo syrup. We model this with
a small tank of water.

$$\begin{aligned} \nu_1 &= 25 \text{ stokes} & \nu_2 &= 0.01 \text{ stokes} \\ L_1 &= 20 \text{ ft} & L_2 &= 2'' \end{aligned}$$

OK, what's U_2 ?

$$U_2 = \frac{\nu_2}{\nu_1} \frac{L_1}{L_2} U_1 = \left(\frac{0.01}{25} \right) \left(\frac{240}{2} \right) U_1$$

(160)

so $U_2 = 0.048 U_1$

if $U_1 = 1 \text{ ft/s}$, $U_2 = 1.46 \text{ cm/s}$
which is a reasonable value!

If there is a free surface
we have to preserve both Re & Fr !
As an example, consider a vortex
in an agitated tank:

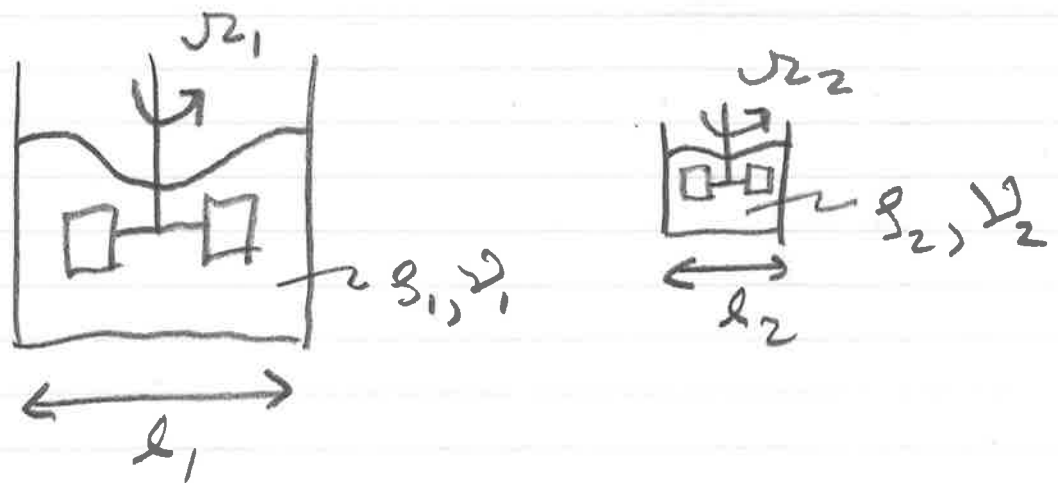

To preserve dynamic similarity
we require:

$$Re_1 = Re_2 \quad ; \quad Fr_1 = Fr_2$$

where $Re = \frac{U l}{\nu}$, $Fr = \frac{U^2}{l g}$ (161)

Note: $U \sim \sqrt{l g}$ since all geometric ratios must be preserved as well! So:

$$\frac{\nu_1 l_1^2}{\nu_1} = \frac{\nu_2 l_2^2}{\nu_2}$$

$$\frac{\nu_1^2 l_1}{g} = \frac{\nu_2^2 l_2}{g}$$

Suppose we are modeling a tank of glycerin w/ one of water. This fixes the ratio ν_1/ν_2

So: $\frac{\nu_1^2}{\nu_2^2} = \frac{l_2}{l_1}$; $\frac{\nu_1 l_1^2}{\nu_2 l_2^2} = \frac{\nu_1}{\nu_2}$

So $\left(\frac{r_1}{r_2}\right)^{3/2} = \frac{v_1}{v_2}$

or $r_2 = r_1 \left(\frac{v_2}{v_1}\right)^{2/3}$

If $v_1/v_2 = 1000$ (about right)

we get $r_2 = \frac{r_1}{100}$

The angular velocity of the impeller is increased :

$\Omega_2 = \Omega_1 \left(\frac{r_1}{r_2}\right)^{1/2} = \Omega_1 \left(\frac{v_1}{v_2}\right)^{1/3}$

What would be the power input ?

Power $\sim \Omega \cdot (\Omega r)^2 \rho \cdot \overset{\text{area}}{r^2} \cdot \underset{\text{lever arm}}{r} \cdot f(Re)$
angular velocity char velocity product \sim pressure

$\sim (\text{ang. velocity}) \cdot (\text{Pressure})(\text{Area})(\text{lever arm})$

$$\sim \Omega^3 \ell^5 \rho f(Re, Fr)$$

But if Re, Fr are constant between model system and original, $f(Re, Fr)$ (unknown Re & Fr dependence) will also be constant!

Thus:

$$\begin{aligned} \frac{(\text{Power})_1}{(\text{Power})_2} &= \frac{\Omega_1^3 \ell_1^5 \rho_1}{\Omega_2^3 \ell_2^5 \rho_2} \\ &= \left(\frac{\Omega_2}{\Omega_1} \right) \left(\frac{\ell_1}{\ell_2} \right)^{10/3} \frac{\rho_1}{\rho_2} \\ &= \left(\frac{\Omega_1}{\Omega_2} \right)^{7/3} \frac{\rho_1}{\rho_2} \end{aligned}$$

which allows us to estimate the power requirements of the full-scale system!

(164)

While strict Dynamic Similarity is often very difficult (or impossible) to achieve, a more approximate form is much easier and more practical. An excellent example is in hull design for surface ships. Strict similarity requires both Re & Fr to be preserved between model and full scale, which isn't really possible. If Re is "high" for both ship & model, however, we may be at some "high Re limit" where viscous effects are unimportant. That would mean that only Fr would have to be kept constant - much easier!

165

Let's see how this works:

We wish to model the behavior of the Enterprise (CVN 65) with a $1/100$ scale model. In this case $U_1 \approx 40 \text{ mph} = 1,800 \text{ cm/s}$, $L_1 \approx 1000 \text{ ft} = 3.0 \times 10^4 \text{ cm}$, $\nu_1 = 0.01 \text{ stokes}$

Thus: $Re_1 = 5.4 \times 10^9$, $Fr_1 = 0.11$

We give up on Re , but try to match

Fr :

$$\frac{U_1^2}{L_1 g} = \frac{U_2^2}{L_2 g} \quad \therefore U_2 = U_1 \left(\frac{L_2}{L_1} \right)^{1/2}$$

or, since $L_2/L_1 = 1/100$,

$$U_2 = \frac{1}{10} U_1 = 4 \text{ mph} - \text{not bad!}$$

We also have:

$$Re_2 = \frac{U_2 L_2}{\nu_2} = 10^{-3} Re_1 = 5.4 \times 10^6$$

166

which is still pretty large!

What about the relation between the force on the model and the force on the ship? If viscosity is unimportant we get:

$$\frac{F_1}{\rho_1 U_1^2 L_1^2} \approx \frac{F_2}{\rho_2 U_2^2 L_2^2}$$

$$\text{or } \frac{F_1}{F_2} \approx \frac{U_1^2 L_1^2}{U_2^2 L_2^2} = 10^6$$

Provided that Re_2 is large enough that the flow around the model is fully turbulent ($Re_2 \gg 10^5$ or so) this actually works pretty well! This has been the basis for testing ship designs over the past century!

(167)

So far we've scaled the N-S equations using the inertial terms (convection of momentum).

This is appropriate for $Re \gg 1$.
 What about low Re ?? Here we use the viscous scalings!

Recall:

$$\rho \frac{U^2}{L} \left[\frac{\partial \tilde{u}^*}{\partial t^*} + \tilde{u}^* \cdot \nabla^* \tilde{u}^* \right] = - \frac{\Delta P_c}{L} \nabla^* P^* + \frac{\mu U}{L^2} \nabla^{*2} \tilde{u}^* + \rho g \tilde{g}^*$$

This time we divide thru by viscous scaling $\frac{\mu U}{L^2}$:

$$\left(\frac{\rho U L}{\mu} \right) \left[\frac{\partial \tilde{u}^*}{\partial t^*} + \tilde{u}^* \cdot \nabla^* \tilde{u}^* \right] = - \left(\frac{\Delta P_c L}{\mu U} \right) \nabla^* P^* + \nabla^{*2} \tilde{u}^* + \frac{\rho g L^2}{\mu U} \tilde{g}^*$$

168

Now we choose ΔP_c s.t.

$$\frac{\Delta P_c l}{\mu U} = 1$$

or $\Delta P_c = \mu \frac{U}{l}$ (scaling for shear stress)

Thus:

$$\text{Re} \left[\frac{\partial \underline{u}^*}{\partial t^*} + \underline{u}^* \cdot \nabla^* \underline{u}^* \right] = - \nabla^* p^* + \nabla^{*2} \underline{u}^* + \frac{\text{Re}}{Fr} \underline{g}^*$$

Now if $\text{Re} \ll 1$ we neglect terms which are of $O(\text{Re})$:

$$- \nabla^* p^* + \nabla^{*2} \underline{u}^* = 0 \left(\text{Re}, \frac{\text{Re}}{Fr} \right)$$

or $\nabla^{*2} \underline{u}^* \approx \nabla^* p^*$

and the CE: $\nabla^* \cdot \underline{u}^* = 0$

These are the Creeping Flow Eqns:

Starting point for low Re flow!

169

So far we've used our knowledge of the flow equations to determine conditions where flows will be dynamically similar. This wasn't really necessary \Rightarrow all that we really had to know was what physical parameters a problem depends on! This is known as Dimensional Analysis.

The key is that Nature knows no units: A "foot" or a "meter" has no physical significance. Thus, any physical relationship must be expressible as a relationship between dimensionless quantities!

Let's see how this works -
 Consider drag on a sphere:

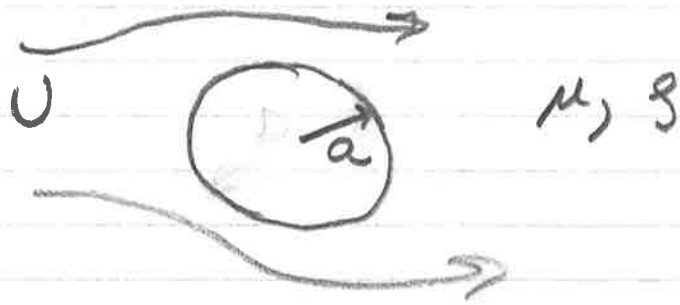

The force is a function of U, a, μ, ρ , but all these are dimensional quantities. How many dimensionless groups can be formed?

Buckingham Π theorem:

$\#$ dimensionless groups = $\#$ parameters

- rank of dimensional matrix

(this is the number of independent fundamental units involved in the problem)

The dimensional matrix \vec{c} given by: 171

$$\begin{array}{c|ccccc} & F & a & s & \mu & U \\ \hline M & 1 & 0 & 1 & 1 & 0 \\ L & 1 & 1 & -3 & -1 & 1 \\ T & -2 & 0 & 0 & -1 & -1 \end{array}$$

Rank = dimension of largest sub-matrix w/ non-zero determinant!

⇒ In this case, we take the first three columns:

$$\left| \begin{bmatrix} 1 & 0 & 1 \\ 1 & 1 & -3 \\ -2 & 0 & 0 \end{bmatrix} \right| = 2 \neq 0 \text{ so rank} = 3$$

By the π theorem:

$$\# \text{ dimensionless groups} = 5 - 3 = 2$$

and thus

$$\pi_1 = f(\pi_2)$$

(172)

We may choose π_1 & π_2 any way we wish provided they are 1) dimensionless and 2) independent (this means that if there are N π groups, the N^{th} can't be formed by any combination of the other $N-1$ groups!)

We usually choose groups so that one involves the dependent parameter of interest, and all the others involve combinations of the independent parameters.

One choice:

$$\frac{F}{\rho U^2 a^2} = f^n \left(\frac{U a \rho}{\mu} \right) \equiv f^n(Re)$$

or, in words, the dimensionless drag is only a function of the Reynolds Number! This is exactly what we got from scaling the N-S eq^{ns}!

Often we can strengthen results if we have additional physical insight. Suppose we have $Re \ll 1$. In this case we expect inertia (& hence ρ) is unimportant:

$$F = \rho^n (U \text{ and } a)$$

M	1	0	1	0
L	1	1	-1	1
T	-2	-1	-1	0

\hookrightarrow rank = 3

$$\therefore 4 - 3 = \underline{\underline{1}} \text{ group}$$

This is the strongest ¹⁷⁴ possible result:

$$\frac{F}{\mu U a} = \underline{\underline{cst}} = 6\pi$$

where the constant is determined by solving Stokes flow eq^s (or from one experiment).

It is extremely important to have a complete list of the applicable parameters. Otherwise the result will be incorrect. As an example, look at flow past an infinitely long cylinder of radius a :

$$F/L = f^{\#}(U, a, \mu, \rho)$$

↑
force/length

Again, there are $5 - 3 = 2$ ⁽¹⁷⁵⁾ dimensionless groups:

$$\frac{F/L}{\rho U^2 a} = f^n \left(\frac{U a \rho}{\mu} \right)$$

So this works fine! What about low Re ?? We anticipate that ρ (inertia) doesn't matter, so we have:

$$\frac{F}{L} = f^n (U, a, \mu)$$

or $4 - 3 = 1$ dimensionless groups.

Thus:

$$\frac{F/L}{U \mu} = \underline{cst}$$

But this suggests that the drag is independent of a ! This can't be correct! This reflects the

Fact that inertia is always ¹⁷⁶ important: there is no solution to the Stokes Eq^s for 2-D flow past a cylinder! This is known as Stokes' Paradox

An approximate solution for $Re \ll 1$ is given by Lamb:

$$\frac{F}{L} \approx 4\pi \frac{U\mu}{\ln\left(\frac{4}{Re}\right) - \gamma + \frac{1}{2}}$$

Euler's const

which depends on Re even as $Re \rightarrow 0!$

The complete reduction of a problem to a single dimensionless group sometimes happens even for functions.

The best example of this is the

expanding shock wave due to a point source explosion studied by G.I. Taylor during WWII. The radius R of the shock will be a function of time t , the density of the gas (before the explosion) ρ_0 , the energy E , the adiabatic exponent $\gamma = 7/5$ for a diatomic gas, and the initial atmospheric pressure P_0 .

Thus:

$$R = f^n(t; \rho_0, E, P_0, \gamma)$$

M	0	0	1	1	1	0
L	1	0	-3	2	-1	0
T	0	1	0	-2	-2	0

Dimensionless

Thus $6 - 3 = 3$ groups!

One is obviously γ , but this won't change if we keep using air!

178

We can construct a reference length and time:

$$\frac{R}{(E/P_0)^{1/3}} = f^n \left(\frac{t}{\left(\frac{E^2 P_0^3}{P_0^5} \right)^{1/6}}, \gamma \right)$$

Which isn't particularly useful. Still, we could plug this into the shock eq'ns & try to solve the problem.

Instead we look at the case of strong explosions such that

$$\frac{P_0 R^3}{E} \ll 1$$

In this case the pressure inside the shock is far greater than that due to the atmosphere P_0 . Thus, we shall assume that P_0 doesn't matter!

Thus we have:

$$R = f^n(t; \rho_0, E, \gamma)$$

or $5 - 3 = 2$ groups!

Since one is still γ , the other is:

$$\frac{R}{\left(\frac{Et^2}{\rho_0}\right)^{1/5}} = f(\gamma) = \text{cst for diatomic gases!}$$

It turns out that this constant is 1.033 from solution of the flow equations! Thus $R \sim t^{3/5}$ and with knowledge of R & t you can calculate E . This was done by Taylor from images of the NM atom bomb tests - while the yields were still classified Top Secret!

As a last point, while ¹⁸⁰ ~~#~~ indep.
fundamental units = ~~#~~ fundamental
units, this isn't always true. As
an example, consider the deflection
produced by a ball sitting on
an elastic solid (e.g. a ball bearing
on a block of rubber):



↳ elasticity = E (psi)

$$h = f^h(F, a, E)$$

these involve $M, L, & T$, so we
might expect $4-3=1$ dimensionless
groups! Thus $\frac{h}{a} = cst ??$

(181)

This can't be correct, since elasticity E must matter!

The problem is in the rank of the dimensional matrix!

$$h = f^n(F, a, E)$$

M	0	1	0	1
L	1	1	1	-1
T	0	-2	0	-2

There exists no 3×3 matrix w/ non-zero determinant, thus rank = 2

So:

$$\frac{h}{a} = f^n\left(\frac{F}{Ea^2}\right)$$

which makes more sense!

Dimensional Analysis is powerful, but be careful and always check to see if your results make sense!

Lubrication Flows

An important problem in fluid mechanics is lubrication theory: the study of the flow in thin films, where hydrodynamic forces keep solid surfaces out of contact, reducing wear. These problems are actually quite simple to solve due to a separation of length scales (one dimension \gg another) which leads to the quasi-parallel flow approximation.

Let's see how this works.

Suppose we look at the squeeze flow between a disk and a plane:

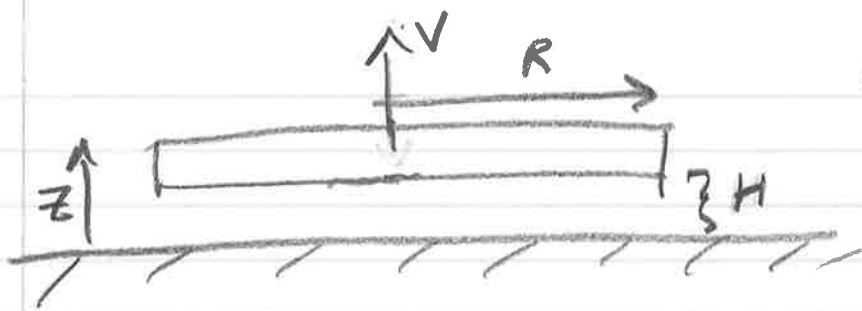

183

The flow in the narrow gap $H/R \ll 1$ will resist the upward motion of the disk. We want to calculate this force. The flow is three dimensional, but $u_\theta = 0$ & we can neglect θ derivatives! Let's start with the C.E.:

$$\frac{1}{r} \frac{\partial}{\partial r} (r u_r) + \frac{1}{r} \frac{\partial u_r}{\partial \theta} + \frac{\partial u_z}{\partial z} = 0$$

\downarrow
0

Because $H/R \ll 1$ we expect that u_r & u_z will need different scales!

$$\text{Let } u_z^* = \frac{u_z}{V}, \quad u_r^* = \frac{u_r}{U}$$

184

We also take:

$$r^* = \frac{r}{R}, \quad z^* = \frac{z}{H}$$

$$\text{So: } \frac{U}{R} \frac{1}{r^*} \frac{\partial}{\partial r^*} (r^* u_r^*) + \frac{V}{H} \frac{\partial u_z^*}{\partial z^*} = 0$$

or, dividing through:

$$\frac{1}{r^*} \frac{\partial}{\partial r^*} (r^* u_r^*) + \frac{RV}{UH} \frac{\partial u_z^*}{\partial z^*} = 0$$

Both terms of the CE must be of the same order for any 2-D problem! Thus we take:

$$\frac{RV}{UH} = 1 \quad \text{or} \quad U = \frac{R}{H} V \gg V$$

Thus the velocity along the gap is much higher (by $O(R/H)$) than the velocity perpendicular to the gap!

This means we have quasi-parallel flow in the radial direction

185

Now for the momentum equations:

$$\text{Let } t^* = \frac{vt}{H}, \quad P^* = \frac{P - P_0}{\Delta P_c}$$

↳ char. time scale = $\frac{H}{V}$

r-momentum:

$$\rho \left(\frac{\partial u_r}{\partial t} + u_r \frac{\partial u_r}{\partial r} + u_z \frac{\partial u_r}{\partial z} \right) = - \frac{\partial P}{\partial r} + \mu \left[\frac{\partial}{\partial r} \left(\frac{1}{r} \frac{\partial}{\partial r} (r u_r) \right) + \frac{\partial^2 u_r}{\partial z^2} \right]$$

where we have ignored θ terms

Scaling:

$$\rho \frac{U^2}{R} \left(\frac{\partial u_r^*}{\partial t^*} + u_r^* \frac{\partial u_r^*}{\partial r^*} + u_z^* \frac{\partial u_r^*}{\partial z^*} \right) = - \frac{\Delta P_c}{R} \frac{\partial P^*}{\partial r^*} + \mu \frac{U}{Hz} \left[\frac{H^2}{R^2} \frac{\partial}{\partial r^*} \left(\frac{1}{r^*} \frac{\partial}{\partial r^*} (r^* u_r^*) \right) + \frac{\partial^2 u_r^*}{\partial z^{*2}} \right]$$

In lubrication flows we expect viscous terms to dominate, so

divide through by $\mu \frac{U}{H^2}$ (186) (leading term)

$$\begin{aligned} & \left(\frac{\rho U H}{\mu} \right) \left(\frac{H}{R} \right) \left(\frac{\partial u_r^*}{\partial t^*} + u_r^* \frac{\partial u_r^*}{\partial r^*} + u_z^* \frac{\partial u_r^*}{\partial z^*} \right) \\ &= - \left(\frac{\Delta P_c H^2}{R \mu U} \right) \frac{\partial p^*}{\partial r^*} + \frac{H^2}{R^2} \frac{\partial}{\partial r^*} \left(\frac{1}{r^*} \frac{\partial}{\partial r^*} (r^* u_r^*) \right) \\ & \quad + \frac{\partial^2 u_r^*}{\partial z^{*2}} \end{aligned}$$

We choose the viscous scaling for the pressure:

$$\left(\frac{\Delta P_c H^2}{R \mu U} \right) = 1 \quad \therefore \Delta P_c = \frac{R \mu U}{H^2}$$

and thus, putting all terms of $O(1)$ on the LHS:

$$\begin{aligned} & \frac{\partial^2 u_r^*}{\partial z^{*2}} - \frac{\partial p^*}{\partial r^*} = - \frac{H^2}{R^2} \frac{\partial}{\partial r^*} \left(\frac{1}{r^*} \frac{\partial}{\partial r^*} (r^* u_r^*) \right) \\ & + \left(\frac{\rho U H}{\mu} \right) \left(\frac{\partial u_r^*}{\partial t^*} + u_r^* \frac{\partial u_r^*}{\partial r^*} + u_z^* \frac{\partial u_r^*}{\partial z^*} \right) \end{aligned}$$

(187)

Provided that $\frac{H}{R} \ll 1$ we can neglect the r -diffusion terms, and provided $\left(\frac{\rho V H}{\mu}\right) \ll 1$ we can ignore the inertial terms.

$$\text{Thus: } \frac{\partial^2 u_r^*}{\partial z^{*2}} = \frac{\partial P^*}{\partial r^*}$$

which is just channel flow! ($P^* = f^*(z^*)$)

With boundary conditions:

$$u_r^* \Big|_{z^*=0,1} = 0 \quad \text{we get:}$$

$$u_r^* = -\frac{\partial P^*}{\partial r^*} \frac{1}{2} z^* (1 - z^*)$$

Now we still need to figure out the pressure gradient. We do this from a mass balance.



Flow out thru top = $V \pi r^2$

Flow in thru sides = $-2\pi r \int_0^H u_r dz$

These must balance!

or

$$V \pi r^2 = -2\pi r \int_0^H u_r dz$$

$$\text{or } \int_0^1 u_r^* dz^* = -\frac{1}{2} r^*$$

$$\text{So: } \int_0^1 \frac{-1}{2} \frac{\partial P^*}{\partial r^*} z^* (1-z^*) dz^* = -\frac{1}{2} r^*$$

$$\frac{\partial P^*}{\partial r^*} = \frac{r^*}{\int_0^1 z^* (1-z^*) dz^*} = \underline{\underline{6 r^*}}$$

Now since $P^*|_{r^*=1} = 0$, we get

$$P^* = -3(1-r^{*2})!$$

(189)

The force is just the integral of the pressure (normal force)

$$F = \int_0^R p \cdot 2\pi r \, dr = \Delta p_c R^2 2\pi \int_0^1 p^* r^* \, dr^*$$
$$= -\frac{3\pi}{2} \left(\frac{\mu U}{H^2} \right) R^2$$

or, since $U = V \frac{R}{H}$,

$$F = -\frac{3\pi}{2} \frac{\mu V R^4}{H^3}$$

Note the force blows up as $H \rightarrow 0$!
This is characteristic of lubrication flows!

How long does it take to detach from the plane? It spends all the time travelling the first little bit!

For a constant force F :

190

$$F = + \frac{3\pi}{2} \frac{\mu R^4}{H^3} \frac{dH}{dt}$$

↑ applied force - balances ↑ = V
resistance

$$\therefore F = - \frac{3\pi}{4} \mu R^4 \frac{d(H^{-2})}{dt}$$

$$\text{So } H^{-2} = H_0^{-2} + \frac{-4}{3\pi \mu R^4} \frac{F}{t}$$

↑
initial separation

Thus we have fallen away when $H^{-2} \approx 0$! This occurs when:

$$t_{\infty} = \frac{3\pi}{4} \frac{\mu R^4}{H_0^2} \frac{1}{F}$$

which approaches infinity as $H_0 \rightarrow 0$

I developed a technique based on this "fall time" concept to measure the roughness of spheres. Basically, the surface imperfections control the initial separation.

An important problem in lubrication theory is the sliding block:

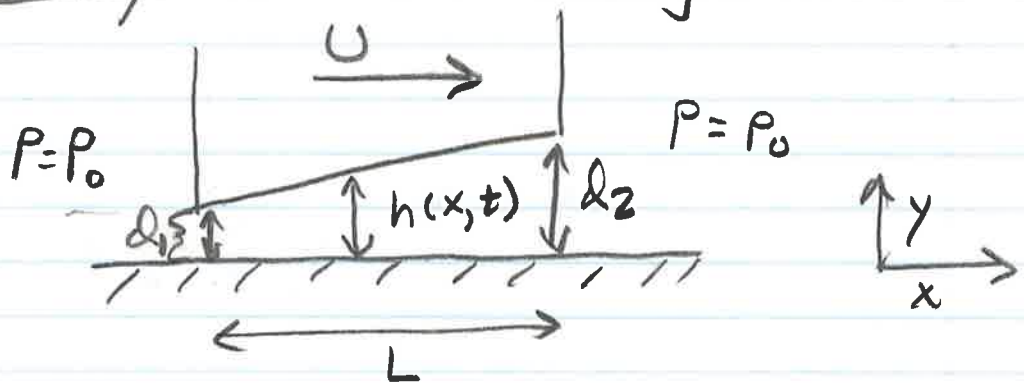

If $H \equiv d_1 \ll L$ we can use lubrication theory to calculate the upward force on the block for some U, d_1, d_2, L , etc.

We have the equations:

$$\rho \left(\frac{\partial \underline{u}}{\partial t} + \underline{u} \cdot \nabla \underline{u} \right) = -\nabla P + \mu \nabla^2 \underline{u}$$

$$\nabla \cdot \underline{u} = 0$$

The flow is two-dimensional, so we

take $u \equiv u_x, v \equiv u_y$

and $u_z = \frac{\partial}{\partial z} = 0$ (no z -dependence)

192

We have the C.E.:

$$\frac{\partial u}{\partial x} + \frac{\partial v}{\partial y} = 0$$

As before, we scale u w/ U ;

x w/ L ; and y w/ H :

$$x^* = \frac{x}{L}, \quad y^* = \frac{y}{H}, \quad u^* = \frac{u}{U}$$

where all $*$ 'd variables are $O(1)$

in the region of interest. To

preserve both terms in the C.E.

we require:

$$v^* = \frac{v}{U} \frac{H}{L}$$

$$\text{Thus } \frac{\partial u^*}{\partial x^*} + \frac{\partial v^*}{\partial y^*} = 0$$

We shall define $\varepsilon \equiv \frac{H}{L} \ll 1$

Thus v is $O(\varepsilon U)$.

OK, now for x -momentum:

(193)

$$\rho \left(\frac{\partial u}{\partial t} + u \frac{\partial u}{\partial x} + v \frac{\partial u}{\partial y} \right) = -\frac{\partial p}{\partial x} + \mu \left(\frac{\partial^2 u}{\partial x^2} + \frac{\partial^2 u}{\partial y^2} \right)$$

Let $t^* = \frac{Ut}{L}$ (e.g., $t_c \equiv \frac{L}{U}$)

and $p^* = \frac{p - p_0}{\Delta p_c}$

Plugging in,

$$\rho \frac{U^2}{L} \left(\frac{\partial u^*}{\partial t^*} + u^* \frac{\partial u^*}{\partial x^*} + v^* \frac{\partial u^*}{\partial y^*} \right) = -\frac{\Delta p_c}{L} \frac{\partial p^*}{\partial x^*} + \mu \left(\frac{U}{L^2} \frac{\partial^2 u^*}{\partial x^{*2}} + \frac{U}{H^2} \frac{\partial^2 u^*}{\partial y^{*2}} \right)$$

We anticipate that the dominant mechanism for momentum transport is viscous shear stresses in the narrow gap. Thus we divide by $\mu \frac{U}{H^2}$, its scaling!

194

So:

$$\left(\frac{\rho U H}{\mu}\right) \left(\frac{H}{L}\right) \left(\frac{\partial u^*}{\partial t^*} + u^* \frac{\partial u^*}{\partial x^*} + v^* \frac{\partial u^*}{\partial y^*}\right) =$$

$$- \frac{\Delta P_c}{\left(\frac{\rho U L}{H^2}\right)} \frac{\partial P^*}{\partial x^*} + \frac{\partial^2 u^*}{\partial y^{*2}} + \frac{H^2}{L^2} \frac{\partial^2 u^*}{\partial x^{*2}}$$

Thus we have the pressure scale

$$\Delta P_c = \frac{\rho U L}{H^2}$$

and:

$$\frac{\partial^2 u^*}{\partial y^{*2}} = \frac{\partial P^*}{\partial x^*} - \epsilon^2 \frac{\partial^2 u^*}{\partial x^{*2}} + \epsilon Re \left(\frac{\partial u^*}{\partial t^*} + u^* \frac{\partial u^*}{\partial x^*} + v^* \frac{\partial u^*}{\partial y^*} \right)$$

We shall ignore terms of $O(\epsilon^2)$ and $O(\epsilon Re)$. Thus:

$$\frac{\partial^2 u^*}{\partial y^{*2}} = \frac{\partial P^*}{\partial x^*}$$

195

Note that we can determine the scale of the force on the block with no further work! The upward force is just:

$$\frac{F}{W} = \int_0^L (P - P_0) Qx$$

$$\text{or } \frac{F}{W} = \Delta P_c L \int_0^1 P^* Qx^*$$

$$\text{so } F = \frac{\rho a L^2 W}{H^2} \cdot \underline{\text{cst}}$$

where to get the cst we have to solve the problem!

Now for the y -momentum eqⁿ:

$$\rho \left(\frac{\partial v}{\partial t} + u \frac{\partial v}{\partial x} + v \frac{\partial v}{\partial y} \right) = - \frac{\partial p}{\partial y} + \mu \left(\frac{\partial^2 v}{\partial x^2} + \frac{\partial^2 v}{\partial y^2} \right)$$

Plugging in our scalings we ¹⁹⁶ get:

$$\frac{\partial P^*}{\partial y^*} = \varepsilon^2 \frac{\partial^2 V^*}{\partial y^{*2}} + \varepsilon^4 \frac{\partial^2 V^*}{\partial x^{*2}} + \varepsilon^3 \text{Re} \left(\frac{\partial V^*}{\partial t^*} + u^* \frac{\partial V^*}{\partial x^*} + v^* \frac{\partial V^*}{\partial y^*} \right)$$

Thus, if we ignore terms of $O(\varepsilon^2, \varepsilon^4, \varepsilon^3 \text{Re})$ we get:

$$\frac{\partial P^*}{\partial y^*} = 0 !$$

This is generically true for problems with separations of length scales $h/L \ll 1$, which also occurs in boundary layer flows we'll study later. Basically, you don't get variations in pressure across the thin dimension, in this case the gap!

OK, we have the scaled eqns: 197

$$\frac{\partial u^*}{\partial x^*} + \frac{\partial v^*}{\partial y^*} = 0$$

$$\frac{\partial^2 u^*}{\partial y^{*2}} = \frac{\partial P^*}{\partial x^*} ; \quad \frac{\partial P^*}{\partial y^*} = 0$$

Now for the B.C.'s:

$$u^* \Big|_{y^*=0} = v^* \Big|_{y^*=0} = 0 \quad \left(\begin{array}{l} y^*=0 \text{ surface} \\ \text{is stationary} \end{array} \right)$$

and for the moving surface:

$$h^* = \frac{h}{H}$$

$$\text{Let } u^* \Big|_{y^*=h^*} = U^* = \frac{U(x,t)}{U}$$

In our case $U^* = 1$ (uniform velocity),
but in general it could be a function
of both x & t .

$$\text{Likewise: } v^* \Big|_{y^*=h^*} = V^* = \frac{V(x,t)}{\epsilon U}$$

For our example problem $V^* = 0$

198

To solve this problem we integrate the x-momentum eq'n over y ! We can do this because P^* isn't a function of y !
(e.g., $\frac{\partial P^*}{\partial y^*} = 0$)

So:

$$u^* = \frac{1}{2} \left(\frac{\partial P^*}{\partial x^*} \right) y^{*2} + C_1(x, t) y^* + C_2(x, t)$$

If we apply B.C. at $y^* = 0$ we get $C_2(x, t) = \underline{\underline{0}}$

Applying B.C. at $y^* = h^*$ gives:

$$u^* = \underbrace{\frac{1}{2} \left(\frac{\partial P^*}{\partial x^*} \right) y^* (y^* - h^*)}_{\text{channel flow}} + \underbrace{U^* \frac{y^*}{h^*}}_{\text{simple shear}}$$

So u^* is just the sum of channel & shear flow!

We still need an equation for p^* .
To get it we look at the C.E.:

$$\frac{\partial v^*}{\partial y^*} = -\frac{\partial u^*}{\partial x^*}$$

We can integrate this to get v^* :

$$v^* = \int_0^{y^*} \left(-\frac{\partial u^*}{\partial x^*}\right) dy^*$$

The lower limit is zero to satisfy the B.C. $v^*|_{y^*=0} = 0$

We can evaluate this at $y^* = h^*$:

$$v^*|_{y^*=h^*} = V^* = \int_0^{h^*} \left(-\frac{\partial u^*}{\partial x^*}\right) dy^*$$

This gives us an equation for the pressure gradient!

$$V^* = \frac{1}{12} \frac{\partial^2 P^*}{\partial x^{*2}} h^{*3} + \frac{1}{4} \frac{\partial P^*}{\partial x^*} h^{*2} \frac{\partial h^*}{\partial x^*} - \frac{1}{2} \frac{\partial U^*}{\partial x^*} h^* + \frac{1}{2} U^* \frac{\partial h^*}{\partial x^*}$$

We can rearrange this:

$$\frac{\partial}{\partial x^*} \left(h^{*3} \frac{\partial P^*}{\partial x^*} \right) = 6 \left[h^* \frac{\partial U^*}{\partial x^*} - U^* \frac{\partial h^*}{\partial x^*} + 2V^* \right]$$

This is known as the Reynolds Lubrication Equation. Together w/ the B.C.'s $P^*|_{x^*=0} = P^*|_{x^*=1} = 0$ we can calculate the pressure!

OK, let's apply this:



$$H \equiv d_1, \quad h = \frac{d_2 - d_1}{L} x + d_1$$

In dimensionless form,

201

$$h^* = 1 + \frac{d_2 - d_1}{d_1} x^*$$

We also have:

$U^* = 1, V^* = 0$ \rightarrow let $d_2 - d_1 = \Delta d$

$$\frac{d}{dx^*} \left(h^{*3} \frac{dP^*}{dx^*} \right) = -6 \frac{\Delta d}{d_1}$$

Integrating once:

$$h^{*3} \frac{dP^*}{dx^*} = -6 \frac{\Delta d}{d_1} x^* + C_1$$

Dividing by h^{*3} and integrating

again:

$$P^* = -6 \frac{\Delta d}{d_1} \int_0^{x^*} \frac{x^*}{\left(1 + \frac{\Delta d}{d_1} x^*\right)^3} dx^*$$

$$+ C_1 \int_0^{x^*} \frac{dx^*}{\left(1 + \frac{\Delta d}{d_1} x^*\right)^3} dx^*$$

where the second constant of

(202)

integration vanishes because
 $P^*|_{x^*=0} = 0.$

Evaluating this at $x^*=1$ and
applying the $P^*|_{x^*=1} = 0$ B.C. yields

$$C_1 = \frac{6 \frac{\Delta d}{d_1} \int_0^1 \frac{x dx}{h^3}}{\int_0^1 \frac{dx}{h^3}} = 6 \left(\frac{\Delta d}{d_1 + d_2} \right)$$

So:

$$P^* = 6 \left(\frac{\Delta d}{d_1 + d_2} \right) \frac{x^* - x^{*2}}{\left(1 + \frac{\Delta d}{d_1} x^* \right)^2}$$

The force is just the integral
of this:

$$F^* = \frac{F}{U \mu L^2 W} = \int_0^1 P^* dx^*$$
$$= 6 \left(\frac{d_1}{\Delta d} \right) \left[\left(\frac{d_1}{\Delta d} \right) \ln \left(1 + \frac{\Delta d}{d_1} \right) - \frac{1}{1 + \frac{1}{2} \frac{\Delta d}{d_1}} \right]$$

203
which looks pretty complex!
In the limit $\frac{\Delta Q}{Q_1} \ll 1$,
however, we get:

$$F^* = \frac{1}{2} \frac{\Delta Q}{Q_1} + O\left(\left(\frac{\Delta Q}{Q_1}\right)^2\right)$$

which is a pretty simple result!
Note that every thing except the
numerical value of the coefficient
could have been obtained without
solving the equations! This is
the importance of knowing how
to scale the equations!

The Stream Function

204

Lubrication flows were an example of quasi-parallel flows: flows where the characteristic length scales were sufficiently different that the 2-D flow was essentially 1-D.

If the length scales are not different, a 2-D flow remains 2-D & we must use a different approach!

Suppose we have an incomp. 2-D flow:

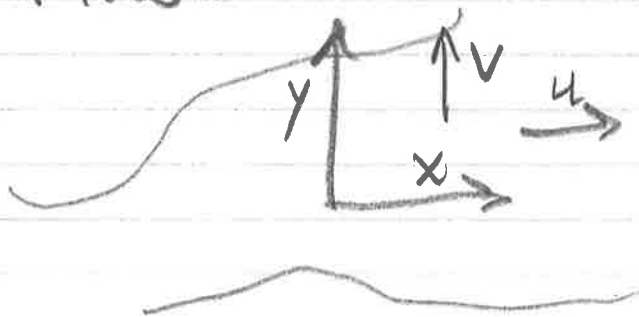

We have the C.E:

$$\frac{\partial u}{\partial x} + \frac{\partial v}{\partial y} = 0$$

If we define the scalar function $\psi(x, y)$ by:

$$u = \frac{\partial \psi}{\partial y}, \quad v = -\frac{\partial \psi}{\partial x}$$

this has the property that the CE is satisfied automatically:

$$\frac{\partial u}{\partial x} + \frac{\partial v}{\partial y} \equiv \frac{\partial^2 \psi}{\partial x \partial y} - \frac{\partial^2 \psi}{\partial y \partial x} = 0$$

Basically, by doing this stream function substitution we are reducing the number of dependent variables (e.g. u, v to ψ) while increasing the order of the differential equation

The stream function has many useful properties! First, it is constant along a streamline.

Remember the material derivative?

$$\frac{D\phi}{Dt} \equiv \frac{\partial\phi}{\partial t} + \underline{u} \cdot \underline{\nabla}\phi$$

the 2nd term is the change in the direction of motion!

For the stream fⁿ $\underline{u} \cdot \underline{\nabla}\psi = 0$

We can prove this:

$$\begin{aligned} \underline{u} \cdot \underline{\nabla}\psi &\equiv u \frac{\partial\psi}{\partial x} + v \frac{\partial\psi}{\partial y} \\ &= \frac{\partial\psi}{\partial y} \frac{\partial\psi}{\partial x} - \frac{\partial\psi}{\partial x} \frac{\partial\psi}{\partial y} = \underline{0} \end{aligned}$$

So curves of constant ψ are streamlines: they follow the motion

of fluid elements! That's why ⁽²⁰⁷⁾ ψ is called the streamfunction!

Another property: suppose we want to calculate the flowrate through any segment of the flow:

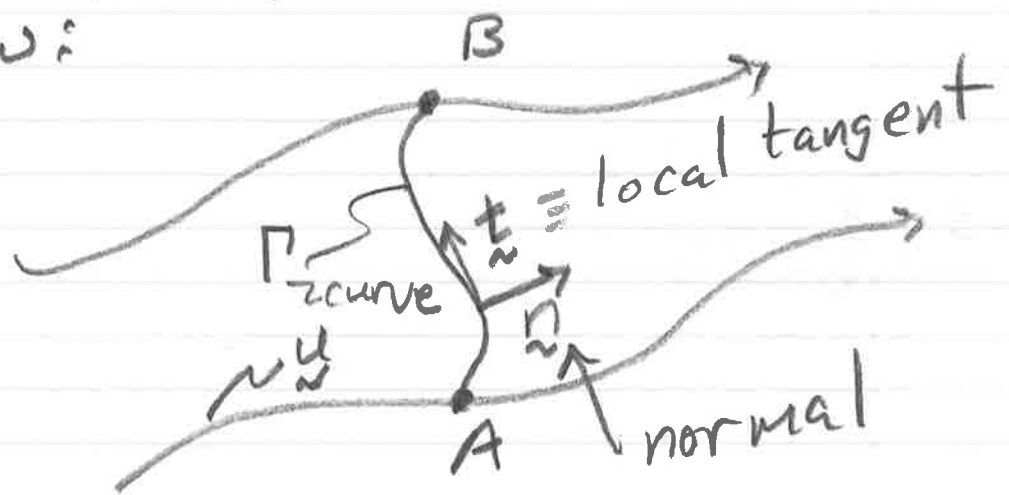

$$\frac{Q}{W} = \int_{\Gamma} (\vec{u} \cdot \vec{n}) ds$$

↑ extension in 3rd direction ↑ path integral

We can evaluate this for any Γ connecting A & B using the streamfunction!

(208)

For a unit normal:

$$\vec{n} = (n_x, n_y)$$

the tangent is $(-n_y, n_x)$

$$\text{So: } \frac{Q}{W} = \int_{\Gamma} (u, v) \cdot (n_x, n_y) ds$$

$$= \int_{\Gamma} \left(\frac{\partial \psi}{\partial y}, -\frac{\partial \psi}{\partial x} \right) \cdot (n_x, n_y) ds$$

$$= \int_{\Gamma} (-n_y, n_x) \cdot \left(\frac{\partial \psi}{\partial x}, \frac{\partial \psi}{\partial y} \right) ds$$

$$= \int_{\Gamma} \underbrace{\vec{t}} \cdot \underbrace{\vec{\nabla} \psi} ds = \psi(B) - \psi(A)$$

↳ variation of ψ along Γ

So the flowrate through any arc from A to B is just the difference in the streamfunction at these points!

OK, how do you get ψ ? ²⁰⁹ Let's plug into the N-S eqns:

$$(1) \rho \left[\frac{\partial u}{\partial t} + u \frac{\partial u}{\partial x} + v \frac{\partial u}{\partial y} \right] = -\frac{\partial p}{\partial x} + \mu \left[\frac{\partial^2 u}{\partial x^2} + \frac{\partial^2 u}{\partial y^2} \right] + \rho g_x$$

$$(2) \rho \left[\frac{\partial v}{\partial t} + u \frac{\partial v}{\partial x} + v \frac{\partial v}{\partial y} \right] = -\frac{\partial p}{\partial y} + \mu \left[\frac{\partial^2 v}{\partial x^2} + \frac{\partial^2 v}{\partial y^2} \right] + \rho g_y$$

Let's just look at the RHS of these eqns:

$$RHS_1 = -\frac{\partial p}{\partial x} + \mu \left[\frac{\partial^3 \psi}{\partial x^2 \partial y} + \frac{\partial^3 \psi}{\partial y^3} \right] + \rho g_x$$

$$RHS_2 = -\frac{\partial p}{\partial y} + \mu \left[-\frac{\partial^3 \psi}{\partial x^3} - \frac{\partial^3 \psi}{\partial x \partial y^2} \right] + \rho g_y$$

We can eliminate the P terms by

the operation:

$$\frac{\partial \text{RHS}_1}{\partial y} - \frac{\partial \text{RHS}_2}{\partial x}$$

$$= \mu \left[\frac{\partial^4 \psi}{\partial x^4} + 2 \frac{\partial^4 \psi}{\partial x^2 \partial y^2} + \frac{\partial^4 \psi}{\partial y^4} \right]$$

$$\equiv \mu \nabla^4 \psi$$

$$\hookrightarrow \nabla^4 \psi \equiv \nabla^2 (\nabla^2 \psi)$$

↳ Biharmonic operator

The LHS is rather nasty:

$$\rho \left[\frac{\partial}{\partial t} (\nabla^2 \psi) + \frac{\partial (\psi, \nabla^2 \psi)}{\partial (x, y)} \right]$$

where:

$$\frac{\partial (\psi, \nabla^2 \psi)}{\partial (x, y)} \equiv \begin{vmatrix} \frac{\partial \psi}{\partial x} & \frac{\partial \psi}{\partial y} \\ \frac{\partial (\nabla^2 \psi)}{\partial x} & \frac{\partial (\nabla^2 \psi)}{\partial y} \end{vmatrix}$$

↳ determinant

Because the LHS is so ⁽²¹¹⁾ nasty,
we usually use this eqⁿ only
for $Re \ll 1$ when we can ignore
the LHS!

For low Re , we have the
Biharmonic Equation:

$$\underline{\nabla^4 \psi = 0}$$

with appropriate B.C.'s

This equation appears in other
physical problems too - particularly
in the deflection of thin elastic
plates! The streamfunction is
identical to the deflection of an
elastic plate (like a thin sheet
of glass) with the same B.C.'s

such as the value of ψ or its ²¹² derivatives on the boundary. This provides a good way of visualizing the spatial dependence of $\psi \Rightarrow$ just visualize the corresponding deflection problem!

Ok, let's work an example! Suppose we have the wiper scraping fluid off a plate. What does the flow look like?

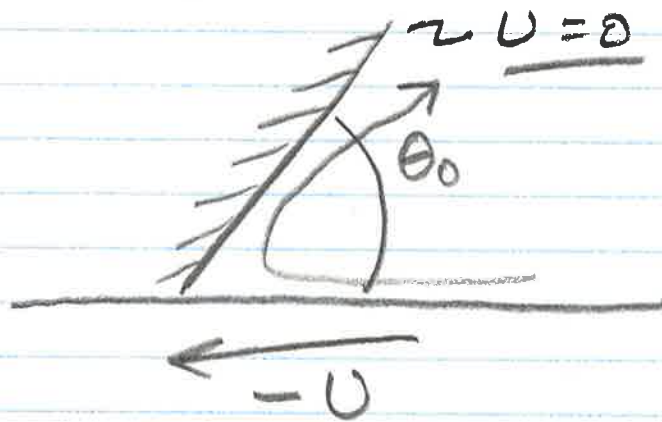

We have $\nabla^4 \psi = 0$

we'll use cylindrical coordinates: 213

$$u_\theta = -\frac{\partial \psi}{\partial r}, \quad u_r = \frac{1}{r} \frac{\partial \psi}{\partial \theta}$$

Now in cylindrical coords, we

have:
$$\nabla^2 \equiv \frac{\partial^2}{\partial z^2} + \frac{1}{r} \frac{\partial}{\partial r} + \frac{1}{r^2} \frac{\partial^2}{\partial \theta^2}$$

w/
$$\nabla^4 \psi \equiv \nabla^2 (\nabla^2 \psi)$$

and B.C.'s:

$$u_r \Big|_{\theta=0} = -U, \quad u_\theta \Big|_{\theta=0} = 0$$

$$u_r \Big|_{\theta=\theta_0} = u_\theta \Big|_{\theta=\theta_0} = 0 \quad \left. \vphantom{u_r} \right\} \text{wiper}$$

In terms of ψ these become:

$$\frac{\partial \psi}{\partial \theta} \Big|_{\theta=0} = -Ur, \quad \frac{\partial \psi}{\partial r} \Big|_{\theta=0} = 0$$

$$\frac{\partial \psi}{\partial r} \Big|_{\theta=\theta_0} = \frac{\partial \psi}{\partial \theta} \Big|_{\theta=\theta_0} = 0$$

The inhomogeneous B.C. ²¹⁴ suggests a solution of the form:

$$\psi = U \nu f(\theta)$$

where $f(\theta)$ has the B.C.'s:

$$f'(0) = -1, f(0) = 0$$

$$f'(\theta_0) = f(\theta_0) = 0$$

Let's see if this works!

$$\nabla^2 \psi = \nabla^2 (U \nu f)$$

$$= \frac{U}{\nu} (f + f'')$$

$$\nabla^4 \psi = \nabla^2 \left[\frac{U}{\nu} (f + f'') \right]$$

$$= \frac{2U}{\nu^3} (f + f'') - \frac{U}{\nu^3} (f + f'') + \frac{1}{\nu^3} (f'' + f'''')$$

$$= \underline{\underline{0}}$$

This reduces to:

$$f'''' + 2f'' + f = 0$$

This has the general solution: 215

$$f = A \sin \theta + B \cos \theta + C \theta \sin \theta + D \theta \cos \theta$$

Where the constants are det.

From the B.C.'s:

$$f'(0) = -1, f'(0) = 0; f(\theta_0) = f'(\theta_0) = 0$$

Now from $f(0) = 0$ we get $B = 0$
the others are harder!

After some algebra:

$$f(\theta) = \frac{-1}{\theta_0^2 - \sin^2 \theta_0} \left[\theta_0^2 \sin \theta - (\theta_0 - \sin \theta_0 \cos \theta_0) \theta \sin \theta - (\sin^2 \theta_0) \theta \cos \theta \right]$$

OK, what is the pressure distribution in the fluid (and on the wiper)?

In cylindrical coords, we have ⁽²¹⁶⁾ the N-S eqns (RHS only!):

$$\frac{\partial P}{\partial r} = \mu \left[\frac{\partial}{\partial r} \left(\frac{1}{r} \frac{\partial}{\partial r} (r u_r) \right) + \frac{1}{r^2} \frac{\partial^2 u_r}{\partial \theta^2} - \frac{2}{r^2} \frac{\partial u_\theta}{\partial \theta} \right]$$

Recall:

$$u_\theta = - \frac{\partial \psi}{\partial r} = -Uf$$

$$u_r = \frac{1}{r} \frac{\partial \psi}{\partial \theta} = Uf'$$

So:

$$\frac{\partial P}{\partial r} = \frac{\mu U}{r^2} \left[-f' + f''' + 2f' \right]$$

$$= \frac{\mu U}{r^2} \left[f' + f''' \right]$$

$$\text{Thus } P \sim \frac{\mu U}{r}$$

(217)

Note that this is singular (blows up) as $r \rightarrow 0$! This isn't even an integrable singularity, as the total force on the wiper diverges as $\log(r)$ as $r \rightarrow 0$! Basically, this huge force pushes the wiper off the surface, leaving a thin film behind!

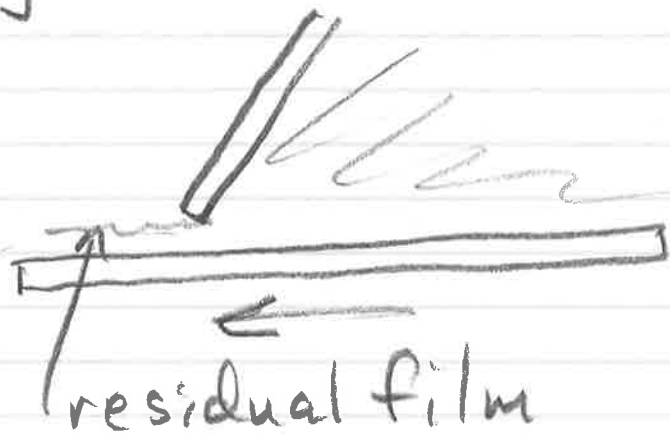

The details of the flow near the tip is fairly nasty - it requires a technique called matched asymptotic expansions.

Flow Past a Sphere via Index Notation

Let's solve this ~~again~~ using index notation!

We have (creeping flow):

$$\frac{1}{\mu} \frac{\partial P}{\partial x_i} = \frac{\partial^2 u_i}{\partial x_j^2} ; \quad \frac{\partial u_j}{\partial x_j} = 0$$

We may take the divergence of the creeping flow equations:

$$\frac{1}{\mu} \frac{\partial^2 P}{\partial x_i^2} = \frac{\partial^2}{\partial x_j^2} \left(\frac{\partial u_i}{\partial x_i} \right) = 0!$$

Thus the Laplacian of the pressure is harmonic!

There are well tabulated solutions to Laplace's eq'n. These are, in the spherical geometry, the decaying harmonics.

$$\frac{1}{r}, \quad \frac{\partial (1/r)}{\partial x_i}, \quad \frac{\partial^2 (1/r)}{\partial x_i \partial x_j}, \dots$$

or:

$$\frac{1}{\mu}, \frac{x_i}{\mu^3}, \left(\frac{x_i x_j}{\mu^5} - \frac{\delta_{ij}}{3\mu^3} \right),$$

$$\frac{x_i x_j x_k}{\mu^7} - \frac{x_i \delta_{jk} + x_j \delta_{ki} + x_k \delta_{ij}}{5\mu^5}, \text{ etc.}$$

If we look again at the creeping flow equations, we get

$$\nabla^2 u_i = \frac{1}{\mu} \frac{\partial P}{\partial x_i}$$

So we can break u_i into a particular solution and a homogeneous solution.

If we know the pressure (we get to this in a bit) then:

$$u_i^{(P)} = \frac{x_i}{2\mu} P$$

Substitute this back in:

$$\frac{\partial^2}{\partial x_j^2} \left(\frac{x_i}{2\mu} P \right) = \frac{\partial}{\partial x_j} \left(\frac{\delta_{ij}}{2\mu} P + \frac{x_i}{2\mu} \frac{\partial P}{\partial x_j} \right)$$

$$= \frac{1}{2\mu} \frac{\partial P}{\partial x_i} + \frac{1}{2\mu} \frac{\partial P}{\partial x_i} + \frac{x_i}{2\mu} \frac{\partial^2 P}{\partial x_i^2}$$

$$= \frac{1}{\mu} \frac{\partial P}{\partial x_i}$$

The homogeneous part is just a harmonic function!

So:

$$u_i = \frac{x_i}{2\mu} p + u_i^{(h)}$$

Let's use this to solve flow past a sphere.

- P is a
- 1) physical scalar
 - 2) linear in U_i
 - 3) harmonic

Note that since a sphere is isotropic, there are no directors describing orientation in the problem!

Before we do translation, let's do the sphere in rotating flow:

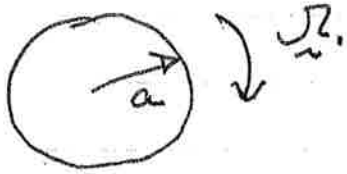

What is pressure, velocity distrib?

$$\nabla^2 u_i = \frac{1}{\mu} \frac{\partial P}{\partial x_i}$$

$$u_i \Big|_{r=a} = \epsilon_{ijk} \Omega_j x_k$$

$$\nabla^2 P = 0, \quad u_i = u_i^h + u_i^p$$

$$u_i^p = \frac{x_i}{2\mu} P, \quad \nabla^2 u_i^h = 0$$

Now P is a physical scalar, linear in Ω_i harmonic!

$$\therefore P = \lambda \epsilon_{ijk} \Omega_k \left(\frac{x_i x_j}{r^5} - \frac{\delta_{ij}}{3r^3} \right)$$

but the harmonic is symmetric & ϵ_{ijk} is anti-sym

$$\therefore \underline{\underline{P=0}}$$

Ok, now left w/ $u_i^{(h)}$:

$u_i^{(h)}$ is physical vector, linear in Ω_i
and is harmonic

$$\therefore u_i^{(h)} = \epsilon_{ijk} \Omega_j \left(\lambda_1 \delta_{ik} \frac{x_k}{r^3} + \lambda_2 \frac{\partial^3 (\frac{1}{r})}{\partial x_i \partial x_j \partial x_k} \right)$$

↑
anti sym

↑
sym

\therefore 4th harmonic doesn't contribute!

$$\therefore u_i = u_i^{(h)} = \lambda \epsilon_{ijk} \Omega_j \frac{x_k}{r^3}$$

or, applying B.C., $\lambda = a^3$

and that's it!

Thus, by inspection,

$$p = \lambda U_i \frac{x_i}{r^3} \quad \swarrow \text{2nd harmonic}$$

$$\text{So } u_i^{(p)} = \frac{x_i}{2\mu} p = \frac{\lambda}{2\mu} U_j \frac{x_i x_j}{r^3}$$

We also need the homogeneous part.

- $u_i^{(h)}$ is
- 1) a physical vector
 - 2) linear in U_i
 - 3) a decaying harmonic

$$\text{Thus: } u_i^{(h)} = U_i + \lambda \frac{U_i}{r^4} + \lambda \frac{U_j}{r^2} \left(\frac{x_i x_j}{r^5} - \frac{\delta_{ij}}{3r^3} \right)$$

choose cst = 1 to match $u_i = U_i$ at ∞

Hence:

$$u_i = U_i + \left(\frac{\lambda}{2\mu} \frac{x_i x_j}{r^3} + \lambda \frac{\delta_{ij}}{r} + \lambda \frac{U_j}{r^2} \left(\frac{x_i x_j}{r^5} - \frac{\delta_{ij}}{3r^3} \right) \right) U_j$$

We now have to determine the costs $\lambda_1, \lambda_2, \lambda_3$:

Apply C.E.

$$\frac{\partial u_i}{\partial x_i} = 0$$

$$\therefore 0 = \left\{ \frac{\lambda}{2\mu} \left(\frac{3x_j + x_i \delta_{ij}}{\mu^3} - 3 \frac{x_i x_j x_i}{\mu^5} \right) \right.$$

$$+ \lambda_1 \left(- \frac{\delta_{ij} x_i}{\mu^3} \right) + \lambda_2 \left(\frac{3x_j + x_i \delta_{ij}}{\mu^5} - \frac{5x_i x_j x_i}{\mu^7} \right.$$

$$\left. + \frac{\delta_{ij} x_i}{\mu^5} \right\} U_j$$

$$= \left\{ \frac{\lambda}{2\mu} \left(\frac{x_j}{\mu^3} \right) - \lambda_1 \frac{x_j}{\mu^3} + \lambda_2 \left(\frac{4x_j}{\mu^5} - \frac{5x_j}{\mu^5} + \frac{x_j}{\mu^5} \right) \right\}$$

$$\therefore \lambda_1 = \frac{\lambda}{2\mu} !$$

We determine the last two costs from the B.C. at $\mu = a$!

we have:

$$u_i = U_i + \left(\frac{\lambda}{2\mu} \left(\frac{\delta_{ij}}{r} + \frac{x_i x_j}{r^3} \right) + \lambda_2 \left(\frac{x_i x_j}{r^5} - \frac{\delta_{ij}}{3r^3} \right) \right) U_j$$

at $r=a$ we get $u_i = \underline{0}$

Now $\frac{x_i}{r} \Big|_{r=a} = n_i$ (unit normal), so:

$$\begin{aligned} u_i \Big|_{r=a} &= U_i + \left(\frac{\lambda}{2\mu a} \left(\delta_{ij} + n_i n_j \right) + \frac{\lambda_2}{a^3} \left(n_i n_j - \frac{\delta_{ij}}{3} \right) \right) U_j \\ &= U_i \left(1 + \frac{\lambda}{2\mu a} - \frac{\lambda_2}{a^3} \frac{1}{3} \right) \\ &\quad + \left(\frac{\lambda}{2\mu a} + \frac{\lambda_2}{a^3} \right) n_i n_j U_j \end{aligned}$$

So we get from the second part:

$$\frac{\lambda}{2\mu a} = -\frac{\lambda_2}{a^3} \quad \lambda_2 = -\frac{a^3 \lambda}{2\mu}$$

$$1 + \frac{\lambda}{2\mu a} + \frac{1}{3} \frac{\lambda}{2\mu a} = 0$$

$$\lambda = -\frac{3}{2} \mu a !$$

So:

$$u_i = U_i - \frac{3}{4} a U_j \left\{ \frac{x_i x_j}{\nu^3} + \frac{\delta_{ij}}{\nu} \right\} \\ + \frac{3}{4} a^3 U_j \left\{ \frac{x_i x_j}{\nu^5} - \frac{\delta_{ij}}{3\nu^3} \right\}$$

$$p = - \frac{3a\mu}{2} U_j \frac{x_j}{\nu^3}$$

What is the drag?? We must determine the stress tensor σ_{ij}

$$F_i = \int_{\partial D} \sigma_{ij} n_j dA$$

where $\sigma_{ij} = -p \delta_{ij} + 2\mu e_{ij}$

$$e_{ij} = \frac{1}{2} \left(\frac{\partial u_i}{\partial x_j} + \frac{\partial u_j}{\partial x_i} \right)$$

(sym. part of rate of strain tensor)

To get this we differentiate:

Let:

$$u_i = U_i - \frac{3}{4} a U_K \left\{ \frac{x_i x_K}{\nu^3} + \frac{\delta_{iK}}{\nu} \right\} \\ + \frac{3}{4} a^3 U_K \left\{ \frac{x_i x_K}{\nu^5} - \frac{1}{3} \frac{\delta_{iK}}{\nu^3} \right\}$$

$$\frac{\partial u_i}{\partial x_j} = -\frac{3}{4} a U_K \left\{ \frac{\delta_{ij} x_K + \delta_{jK} x_i}{r^3} - 3 \frac{x_i x_j x_K}{r^5} - \frac{\delta_{iK} x_j}{r^3} \right\}$$

$$+ \frac{3}{4} a^3 U_K \left\{ \frac{\delta_{ij} x_K + \delta_{jK} x_i}{r^5} - 5 \frac{x_i x_j x_K}{r^7} + \frac{\delta_{iK} x_j}{r^5} \right\}$$

Now e_{ij} is just the sym. part of this:

$$e_{ij} = -\frac{3}{4} a U_K \left\{ \frac{\delta_{ij} x_K}{r^3} - 3 \frac{x_i x_j x_K}{r^5} \right\}$$

$$+ \frac{3}{4} a^3 U_K \left\{ \frac{\delta_{ij} x_K + \delta_{jK} x_i + \delta_{iK} x_j}{r^5} - 5 \frac{x_i x_j x_K}{r^7} \right\}$$

Thus we have the stress:

$$\bar{\sigma}_{ij} = \frac{3 a \mu}{2} U_K \frac{x_K}{r^3} \delta_{ij}$$

$$- \frac{3}{2} a \mu U_K \left\{ \frac{\delta_{ij} x_K}{r^3} - 3 \frac{x_i x_j x_K}{r^5} \right\}$$

$$+ \frac{3}{2} a^3 \mu U_K \left\{ \frac{\delta_{ij} x_K + \delta_{jK} x_i + \delta_{iK} x_j}{r^5} - 5 \frac{x_i x_j x_K}{r^7} \right\}$$

Now at the surface of the sphere

$$r = a \quad \text{and} \quad x_i = r_i a$$

Thus we get:

$$\left. \begin{aligned} \sigma_{ij} \Big|_{r=a} &= \frac{3}{2} \frac{\mu}{a} U_k \left\{ + 3 n_i n_j n_k \right. \\ &+ \left. \delta_{ij} n_k + \delta_{jk} n_i + \delta_{ik} n_j - 5 n_i n_j n_k \right\} \end{aligned} \right\}$$

And thus:

$$\left. \begin{aligned} \sigma_{ij} n_j \Big|_{r=a} &= \frac{3}{2} \frac{\mu}{a} U_k \left\{ \cancel{3 n_i n_k} + \cancel{n_i n_k} + n_i n_k \right. \\ &+ \left. \delta_{ik} - \cancel{5 n_i n_k} \right\} = \frac{3}{2} \frac{\mu}{a} U_i \quad (\text{constant!}) \end{aligned} \right\}$$

$$\begin{aligned} F_i &= \int_{r=a} \sigma_{ij} n_j \, dA = (4\pi a^2) \left(\frac{3}{2} \frac{\mu}{a} U_i \right) \\ &= 6\pi \mu a U_i \end{aligned}$$

(Stokes Law!)

(218)

A classic stream function problem is creeping flow ($Re \ll 1$) past a sphere.

Suppose a sphere of radius a is moving w/ velocity U in the z -direction. The flow is fully 3-D, but it is axisymmetric.

We choose a spherical coord system such as that given below:

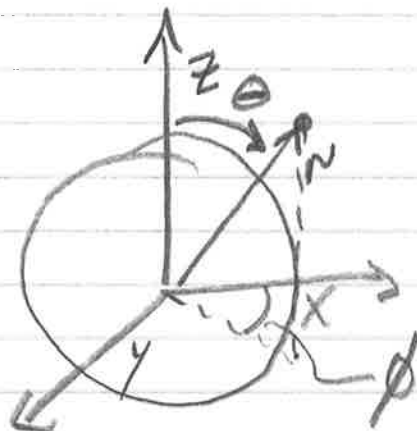

Basically, θ is the latitude & ϕ is the longitude!

Thus :

$$z = r \cos \theta$$

$$x = r \sin \theta \cos \phi$$

$$y = r \sin \theta \sin \phi$$

For this problem $u_\phi = 0$ and there is no ϕ dependence!

We have the B.C.'s :

$$u_r \Big|_{r=a} = U \cos \theta; \quad u_\theta \Big|_{r=a} = -U \sin \theta$$

$$u_r, u_\theta \rightarrow 0 \text{ as } r \rightarrow \infty$$

In spherical coordinates we have the C.E. :

$$\frac{1}{r^2} \frac{\partial}{\partial r} (r^2 u_r) + \frac{1}{r \sin \theta} \frac{\partial}{\partial \theta} (u_\theta \sin \theta) + \frac{1}{r \sin \theta} \frac{\partial}{\partial \phi} (u_\phi) = 0$$

The structure of the CE ²²⁰ suggests;

$$u_r = \frac{1}{r^2 \sin \theta} \frac{\partial \psi}{\partial \theta}$$

$$u_\theta = \frac{1}{r \sin \theta} \frac{\partial \psi}{\partial r}$$

Which automatically satisfies the CE!

This is not the same as ψ for 2-D flow & leads to a different equation! For axisymmetric flows at $Re = 0$:

$$E^4 \psi = 0$$

where:

$$E^2 \equiv \frac{\partial^2}{\partial r^2} + \frac{\sin \theta}{r^2} \frac{\partial}{\partial \theta} \left(\frac{1}{\sin \theta} \frac{\partial}{\partial \theta} \right)$$

OK, how do we solve this? We look at the B.C.'s:

$$u_\theta \Big|_{r=a} = \frac{1}{r \sin \theta} \frac{\partial \psi}{\partial r} \Big|_{r=a} = -U \sin \theta$$

$$\text{thus } \frac{\partial \psi}{\partial r} \Big|_{r=a} = -U a \sin^2 \theta$$

$$\text{and } u_r \Big|_{r=a} = \frac{1}{r^2 \sin \theta} \frac{\partial \psi}{\partial \theta} \Big|_{r=a} = U \cos \theta$$

$$\text{Thus: } \frac{\partial \psi}{\partial \theta} \Big|_{r=a} = -U a^2 \sin \theta \cos \theta$$

The structure of these B.C.'s suggests a solution of the form:

$$\psi = \sin^2 \theta f(r)$$

We'll try this and see if it works!

(222)

Plug into B.C.'s:

$$\left. \frac{\partial \psi}{\partial \theta} \right|_{r=a} = 2 \sin \theta \cos \theta f(a) = -Ua^2 \sin \theta \cos \theta$$

$$\text{Thus } f(a) = -\frac{1}{2} Ua^2$$

$$\left. \frac{\partial \psi}{\partial r} \right|_{r=a} = \sin^2 \theta f'(a) = -Ua \sin^2 \theta$$

$$\text{Thus } f'(a) = -Ua$$

So far, so good! Now for the B.C.'s
at $r \rightarrow \infty$:

$$u_{\theta} \Big|_{r \rightarrow \infty} = 0 = \sin \theta \left. \frac{f'(r)}{r} \right|_{r \rightarrow \infty}$$

$$\text{So } \lim_{r \rightarrow \infty} \frac{f'(r)}{r} = 0$$

and

$$u_r \Big|_{r \rightarrow \infty} = 0 = -\cos \theta \left. \frac{f(r)}{r^2} \right|_{r \rightarrow \infty}$$

$$\text{So } \lim_{r \rightarrow \infty} \frac{f(r)}{r^2} = 0$$

Now we have to derive a P.E. for $f(r)$:

$$E^4 \psi \equiv E^2 (E^2 \psi) \equiv E^2 (E^2 (\sin^2 \theta f(r)))$$

Recall:

$$\begin{aligned} E^2 \psi &= \frac{\partial^2 \psi}{\partial r^2} + \frac{\sin \theta}{r^2} \frac{\partial}{\partial \theta} \left(\frac{1}{\sin \theta} \frac{\partial \psi}{\partial \theta} \right) \\ &= \sin^2 \theta f'' + \frac{f}{r^2} \sin \theta \frac{\partial}{\partial \theta} \left(\frac{1}{\sin \theta} \frac{\partial \sin^2 \theta}{\partial \theta} \right) \\ &= \left(f'' - 2 \frac{f}{r^2} \right) \sin^2 \theta \end{aligned}$$

Similarly,

$$\begin{aligned} E^4 \psi &= \left[f^{IV} - \frac{4}{r^2} f'' + \frac{8}{r^3} f' - \frac{8}{r^4} f \right] \sin^2 \theta \\ &= \underline{\underline{0}} \end{aligned}$$

Thus we get the 4th order ODE:

$$r^4 f^{IV} - 4r^2 f'' + 8rf' - 8f = 0$$

$$\text{w/ B.C.'s: } f(a) = -\frac{1}{2} Ua^2, \quad f'(a) = -Ua$$

$$\lim_{r \rightarrow \infty} \frac{f(r)}{r^2} = 0, \quad \lim_{r \rightarrow \infty} \frac{f'(r)}{r} = 0 \quad (224)$$

Now since all the terms in the ODE have the form $r^i f^{(i)}$, the general solution is of the form:

$$f(r) = r^n$$

Plugging in yields the polynomial:

$$n(n-1)(n-2)(n-3) - 4n(n-1) + 8n - 8 = 0$$

This has 4 roots:

$$n = -1, 1, 2, 4$$

Thus:

$$f(r) = \frac{e}{r} + br + cr^2 + dr^4$$

where the constants are determined from the B.C.'s!

The condition that $f(r)$ die off at $r \rightarrow \infty$ requires $c = d = 0$

Thus:

$$f(r) = \frac{e}{r} + br$$

Now at $r = a$:

$$f(a) = \frac{e}{a} + ba = -\frac{1}{2} Ua^2$$

and

$$f'(a) = -\frac{e}{a^2} + b = -Ua$$

Solving for e & b we get:

$$e = \frac{1}{4} Ua^3, \quad b = -\frac{3}{4} Ua$$

$$\psi = Ua^2 \left(\frac{1}{4} \frac{a}{r} - \frac{3}{4} \frac{r}{a} \right) \sin^2 \theta$$

which gives the velocities:

$$u_r = -\frac{U \cos \theta}{2} \left\{ \left(\frac{a}{r} \right)^3 - 3 \frac{a}{r} \right\}$$

$$u_\theta = -\frac{U \sin \theta}{4} \left\{ \left(\frac{a}{r} \right)^3 + 3 \frac{a}{r} \right\}$$

We can also obtain the pressure

distribution:

(226)

$$P = P_0 + \frac{3}{2} \mu a U \frac{\cos \theta}{r^2}$$

It's important to note that the velocity dies off only as $O(\frac{a}{r})$ for large r . This means that as $Re \rightarrow 0$, the disturbance produced by a sphere is felt at very large distances! You have to go ~ 100 radii for the velocity to drop to 1% of the value at the sphere! This means that boundaries ^(e.g., vessel walls) have a strong influence on the motion of objects — an important result in low Re flows!

OK, now we have the velocity and the pressure. What about the drag? (force exerted by the fluid

on the sphere!)

$$\vec{F} = \int_{r=a} \underline{\underline{\sigma}} \cdot \underline{\underline{n}} \, dA$$

Recall that :

$$\underline{\underline{\sigma}} = -p \underline{\underline{\delta}} + \underline{\underline{\tau}}$$

↑ isotropic part

↙ deviatoric stress

Thus:

$$\vec{F} = \int_{\partial D} -p \underline{\underline{n}} \, dA + \int_{\partial D} \underline{\underline{\tau}} \cdot \underline{\underline{n}} \, dA$$

normal forces (form drag) shear forces (skin friction)

At high Re , form drag is large, while skin friction is negligible!
At low Re , both are comparable!

The integrals are a bit messy ²²⁸ to evaluate, but eventually you get:

$$\begin{aligned}\vec{F} &= -\hat{e}_z \left\{ \underbrace{2\pi\mu a U}_{\text{form drag}} + \underbrace{4\pi\mu a U}_{\text{skin friction}} \right\} \\ &= -6\pi\mu a U \hat{e}_z\end{aligned}$$

This is known as Stokes' Law and is of fundamental importance in the study of suspensions at low Re. You should remember this!!

Note that from pure dimensional analysis we had:

$$\frac{F}{\mu U a} = c \text{ st for } Re \ll 1$$

Getting the value of the constant took all the effort!

There's an alternative way to ⁽²²⁴⁾ calculate the drag: Do an Energy Balance

Since there's no accumulation of momentum (kinetic energy) all of the work done by the sphere on the fluid is dissipated in heat! The work done by the sphere on the fluid is just:

$$\frac{\text{Work}}{\text{Time}} = \vec{U} \cdot \vec{F} \quad \leftarrow \text{force on fluid}$$

= Total viscous dissipation

The viscous dissipation per unit volume is $\tau : \nabla \vec{u}$

or in index notation:

$$\tau_{ij} \frac{\partial u_i}{\partial x_j}$$

Thus:

$$\underline{F} \cdot \underline{U} = \int_{r>a} \underline{\tau} : \underline{\nabla} \underline{u} \, dV$$

↳ all volume exterior to sphere

This yields the same result!



Before we leave creeping flow, (e.g. $Re \ll 1$) let's look at another special property: Minimum Dissipation Theorem. Proving this is beyond this course (it's covered in 544), but we can use the result!

(231)

Among the set of all vector fields \underline{u} which satisfy:

1) the no-slip conditions on a body (e.g. $\underline{u}|_{\partial D} = \underline{U}(\underline{x})$)
and

2) satisfy $\nabla \cdot \underline{u} = 0$ (continuity)
then the velocity field which also satisfies the creeping flow equations results in the minimum viscous dissipation!

Since dissipation $\equiv \underline{F} \cdot \underline{U}$, this provides a means of estimating the drag on a complex shape!

Example: what is the drag on a cube w/ sides of length s ?

232

A corollary to the minimum dissip. theorem is that the drag on any object is less than that on one which completely encloses it! This is only true for $Re \ll 1$

OK, how about the cube?

It's drag is greater than that of a sphere of radius $s/2$ (which it encloses) but less than that of a sphere of radius $s \cdot \frac{\sqrt{3}}{2}$ which encloses it!

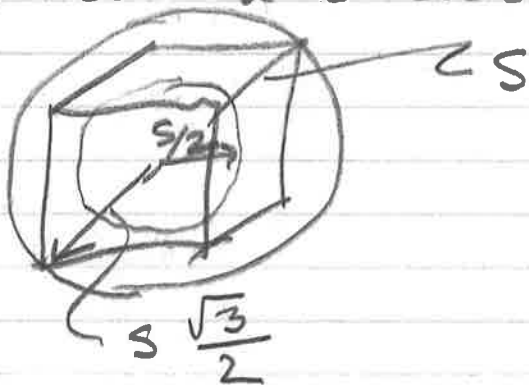

Thus: $6\pi\mu U \frac{s}{2} < F_{\text{cube}} < 6\pi\mu U s \frac{\sqrt{3}}{2}$

These are rigorous bounds ²³³ provided $Re \ll 1$ (higher Re is very different!). We can also estimate the drag by just taking the geometric mean:

$$F_{\text{cube}} \approx 6\pi\mu U S \frac{(3)^{1/4}}{2}$$

Another consequence of the minimum dissipation theorem is that streamlining an object by enclosing it in a smooth shell only increases the drag! This is certainly not true for higher Re !

234

OK, we've looked at low Re flows. Now let's look at high Re limit.

Recall the high Re scaling:

$$\tilde{x}^* = \frac{\tilde{x}}{L}, \quad \tilde{u}^* = \frac{\tilde{u}}{U}, \quad t^* = \frac{t}{\left(\frac{L}{U}\right)}$$

$$P^* = \frac{P - P_\infty}{(\rho U^2)} \leftarrow \text{inertial scaling}$$

Thus:

$$\left(\frac{\partial \tilde{u}^*}{\partial t^*} + \tilde{u}^* \cdot \nabla^* \tilde{u}^* \right) = -\nabla^* P^* + \frac{1}{Re} \nabla^{*2} \tilde{u}^* + \frac{1}{Fr} \tilde{g}^*$$

For low Re we threw out inertial terms. For high Re we throw out viscous terms ($O(\frac{1}{Re})$)! This yields the inviscid (zero viscosity)

Euler eqns:

$$\rho \frac{D \tilde{u}}{Dt} = -\nabla P + \rho \tilde{g}$$

(235)

We can eliminate the $\rho \underline{g}$ term
by defining an augmented pressure

$$P \equiv p - \rho \underline{g} \cdot \underline{x}$$

Thus $\nabla P = \nabla p - \rho \underline{g}$
provided ρ is cst

So:

$$\rho \frac{\partial \underline{u}}{\partial t} + \rho \underline{u} \cdot \nabla \underline{u} = -\nabla P$$

We have the vector identity:

$$\underline{u} \cdot \nabla \underline{u} = \underbrace{\frac{1}{2} \nabla (\underline{u} \cdot \underline{u})}_{\nabla \left(\frac{1}{2} u^2 \right)} - \underline{u} \times \underbrace{(\nabla \times \underline{u})}_{\underline{\omega} \text{ (vorticity)}}$$

Thus:

$$\rho \frac{\partial \underline{u}}{\partial t} + \nabla \left(\frac{1}{2} \rho u^2 \right) + \nabla P = \rho \underline{u} \times \underline{\omega}$$

or

$$\rho \frac{\partial \underline{u}}{\partial t} + \nabla \left(\frac{1}{2} \rho u^2 + P - \rho \underline{g} \cdot \underline{x} \right) = \rho \underline{u} \times \underline{\omega}$$

These equations are most ²³⁶ useful
for irrotational flow (e.g., $\underline{\omega} = 0$)

$$\underline{\omega} \equiv \underline{\nabla} \times \underline{u}$$

If a flow starts out irrotational,
then only the viscous term can
produce vorticity! Thus, if the
flow is inviscid, it stays irrotational!

You can prove this by taking the curl
of the N-S equations, but it gets a little
messy!

Anyway, if $\underline{\omega} = \underline{0}$ we get:

$$\rho \frac{\partial \underline{u}}{\partial t} + \underline{\nabla} \left(\frac{1}{2} \rho u^2 + p - \rho \underline{g} \cdot \underline{x} \right) = 0$$

If the flow is also steady:

$$\underline{\nabla} \left(\frac{1}{2} \rho u^2 + p - \rho \underline{g} \cdot \underline{x} \right) = 0$$

How does this vary along a streamline? (237)
From Lagrangian perspective, time rate of change (for steady flow) along streamline is just:

$$\vec{u} \cdot \vec{\nabla} \quad (\leftarrow \text{whatever you're interested in!})$$

Thus:

$$\vec{u} \cdot \vec{\nabla} \left(\frac{1}{2} \rho u^2 + p - \rho \vec{g} \cdot \vec{x} \right) = 0$$

or $\frac{1}{2} \rho u^2 + p + \rho g z = \underline{\underline{cst}}$
along a streamline!

(Note: $-\vec{g} \cdot \vec{x} = (-\hat{e}_z g \cdot \vec{x}) = g z$
if \vec{g} is in $-z$ direction!)

This is known as Bernoulli's Eq'n, valid for steady, inviscid, irrotational flows!

What is the physical interp. of Bernoulli's eq'n? Conservation of Mechanical Energy! If we have no frictional losses (e.g., $\mu = 0 \Rightarrow$ inviscid flow) then mechanical energy is conserved along a streamline!

$$\frac{1}{2} \rho u^2 \equiv \text{Kinetic Energy / Volume}$$

$$P + \rho g z \equiv \text{"Potential Energy" / Volume}$$

Thus, if one goes up, the other goes down!

How can we use this? Look at a jet of water at high Re:

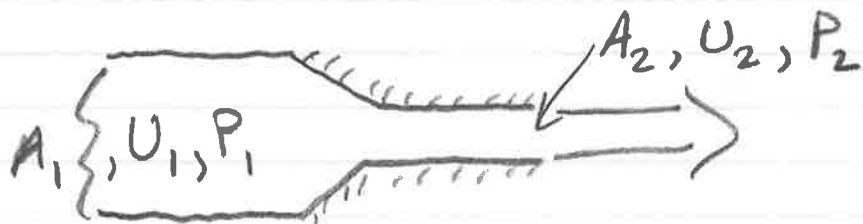

239

Neglecting losses, what is the velocity of the jet, the force on the nozzle?

Conservation of Mass: $U_1 A_1 = U_2 A_2$

Conservation of mech. Energy
(e.g., Bernoulli's eq'n):

$$\frac{1}{2} \rho U_1^2 + P_1 = \frac{1}{2} \rho U_2^2 + P_2$$

$$\begin{aligned} \text{Thus } P_1 - P_2 &= \frac{1}{2} \rho (U_2^2 - U_1^2) \\ &= \frac{1}{2} \rho U_1^2 \left(\frac{U_2^2}{U_1^2} - 1 \right) \\ &= \frac{1}{2} \rho U_1^2 \left(\left(\frac{A_1}{A_2} \right)^2 - 1 \right) \end{aligned}$$

$$\text{So } U_1 = \left[\frac{2(P_1 - P_2)}{\rho \left(\left(\frac{A_1}{A_2} \right)^2 - 1 \right)} \right]^{1/2}$$

$$\text{and } U_2 = \frac{A_1}{A_2} U_1$$

(240)

This assumes that the flow field is uniform across inlet & outlet, & that there are no frictional losses.

What about the force on the nozzle? We did this sort of problem before!

$$\int_{\partial D} (\rho \underline{u}) \underline{u} \cdot \underline{n} \, dA = \sum \underline{F} \quad (\text{force exerted on fluid})$$

We are interested in x-component (flow direction), thus:

$$\begin{aligned} \sum F_x &= \int_{\partial D} (\rho u_x) \underline{u} \cdot \underline{n} \, dA = \rho U_1 (-U_1 A_1) + \rho U_2 (U_2 A_2) \\ &= \rho (U_2^2 A_2 - U_1^2 A_1) = \rho U_1^2 A_1 \left(\frac{U_2^2}{U_1^2} \frac{A_2}{A_1} - 1 \right) \\ &= \rho U_1^2 A_1 \left(\frac{A_1}{A_2} - 1 \right) \end{aligned}$$

But from Bernoulli's eqⁿ: (241)

$$gU_1^2 = \frac{2(P_1 - P_2)}{\left(\frac{A_1}{A_2}\right)^2 - 1}$$

So:

$$\Sigma F_x = 2A_1(P_1 - P_2) \frac{\left(\frac{A_1}{A_2} - 1\right)}{\left(\frac{A_1}{A_2}\right)^2 - 1}$$

$$= \frac{2A_1(P_1 - P_2)}{\frac{A_1}{A_2} + 1} = \frac{2A_1A_2(P_1 - P_2)}{A_1 + A_2}$$

Now $\Sigma F_x = -F_N + P_1A_1 - P_2A_2$ ↙ force exerted by fluid on nozzle

So

$$F_N = P_1A_1 - P_2A_2 - \frac{2A_1A_2(P_1 - P_2)}{A_1 + A_2}$$

Now if $P_2 = 0$ (atmospheric pressure forces on nozzle are neglected) then:

$$F_N = P_1A_1 \left(1 - \frac{2A_2}{A_1 + A_2}\right)$$

242

Let's look at a more complicated problem: what are the forces on a plate near a spool of thread as depicted below:

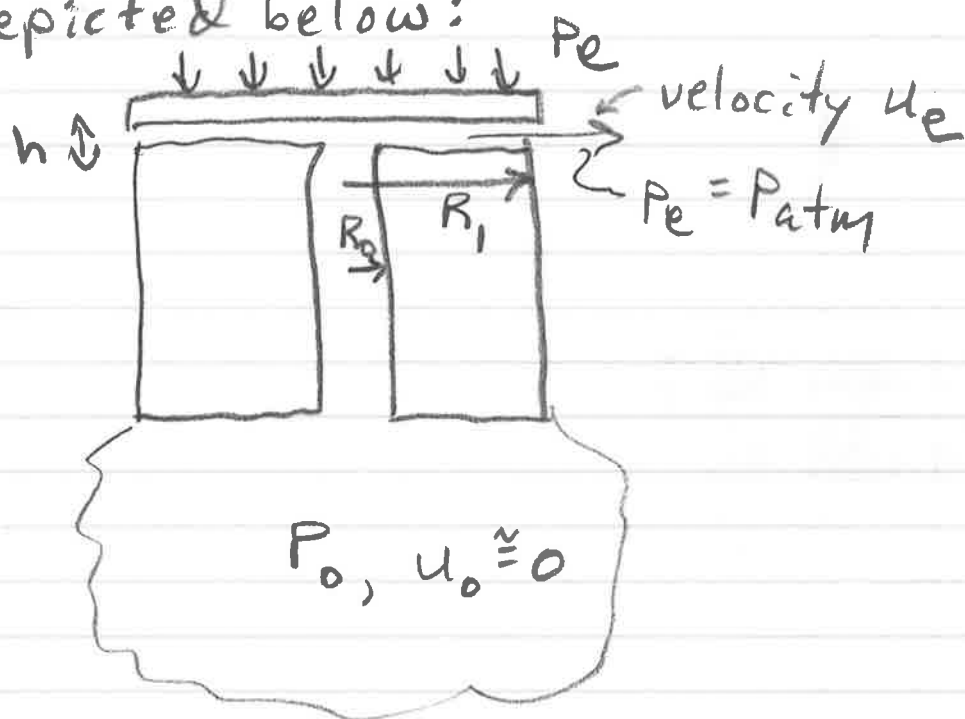

What happens? Can we blow the plate off the spool of thread?

First, what is u_e ? We shall assume inviscid, irrotational flow. Thus:

$$\frac{1}{2} \rho u_e^2 + P_e = \frac{1}{2} \rho u_0^2 + P_0$$

243

So we have:

$$\frac{1}{2} \rho u_e^2 = P_0 - P_e$$

To solve, we need the radial velocity everywhere under the plate!
This, in turn, gives us the pressure!

By conservation of mass:

$$2\pi r h u(r) = 2\pi R_1 h u_e$$

$$\therefore u(r) = \frac{R_1}{r} u_e, \text{ at least for}$$

$r > R_0$. We can take $u = 0$

for $r < R_0$ (stagnation flow -
it's a bit approximate!)

$$\text{So: } \frac{1}{2} \rho u_e^2 + P_e = \frac{1}{2} \rho u^2 + P$$

$$\text{or } P = P_e + \frac{1}{2} \rho u_e^2 \left(1 - \frac{u^2}{u_e^2}\right)$$

$$= \begin{cases} P_e + (P_0 - P_e) \left(1 - \left(\frac{R_1}{r}\right)^2\right) & R_0 < r < R_1 \\ P_0 & 0 < r < R_0 \text{ (stagnation)} \end{cases}$$

To get the net force on the plate, we need to integrate:

$$F = \int_0^{R_1} (P - P_e) 2\pi r dr$$

$$= (P_0 - P_e) \pi R_0^2 + \int_{R_0}^{R_1} (P_0 - P_e) \left(1 - \frac{R_1^2}{r^2}\right) 2\pi r dr$$

$$= \pi R_1^2 (P_0 - P_e) (1 - 2 \ln(R_1/R_0))$$

So if $2 \ln R_1/R_0 > 1$ the net force drives the plate towards the spool! The harder you blow, the tighter it sticks! The critical ratio is

$$R_1/R_0 > 1.65$$

Bernoulli problems offer lots of interesting, counter-intuitive examples like this!

OK, so far we've just looked at the case of Uniform Flow. What happens when the flow is non-uniform? Bernoulli's equation still applies, but now \underline{u} will be more complex!

If a flow is irrotational (e.g., $\nabla \times \underline{u} = 0$), then \underline{u} must be able to be represented by the gradient of a scalar potential!

We take:

$$\underline{u} = -\nabla \phi$$

What does ϕ satisfy? Remember the C.E.:

$$\nabla \cdot \underline{u} = 0$$

Thus:

$$\nabla \cdot \underline{u} = -\nabla^2 \phi = 0$$

so ϕ satisfies Laplace's ²⁴⁶ eqn!
Such problems are easy to solve
for many geometries!

Problems for which $\underline{u} = -\underline{\nabla}\phi$, $\nabla^2\phi = 0$
are known as ideal potential flow,
and occur for steady, inviscid
irrotational flow fields!

Let's work a classic example -
flow past a cylinder

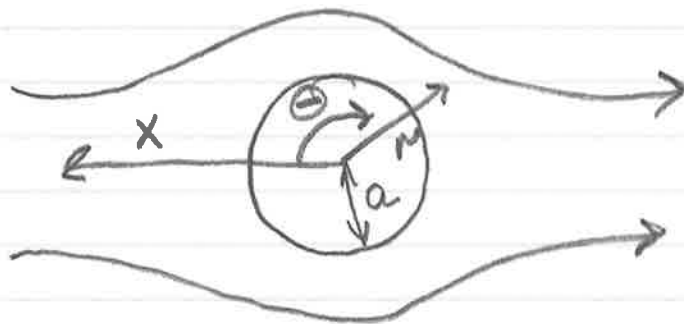

$$\underline{u} = -\underline{\nabla}\phi, \quad \nabla^2\phi = 0$$

In cylindrical coordinates:

$$\frac{\partial^2\phi}{\partial r^2} + \frac{1}{r}\frac{\partial\phi}{\partial r} + \frac{1}{r^2}\frac{\partial^2\phi}{\partial\theta^2} = 0$$

247

What are the B.C.'s?

$$u_\theta \Big|_{r \rightarrow \infty} \equiv -\frac{1}{r} \frac{\partial \phi}{\partial \theta} \Big|_{r \rightarrow \infty} = U \sin \theta$$

$$u_r \Big|_{r \rightarrow \infty} \equiv -\frac{\partial \phi}{\partial r} \Big|_{r \rightarrow \infty} = -U \cos \theta$$

$$\nabla \phi \Big|_{r \rightarrow \infty} = \hat{e}_x U$$

What about the B.C.'s on the cylinder?? We've thrown out viscosity (inviscid flow), so the no-slip eq'n no longer applies! Instead, we have no flow thru the object!

$$\vec{u} \cdot \vec{n} \Big|_{\partial D} = 0$$

Thus

$$-\nabla \phi \cdot \vec{n} \Big|_{r=a} = 0 \equiv u_r \Big|_{r=a}$$

How do we solve this? Look at 248
inhomogeneous B.C.'s (those at $r \rightarrow \infty$)

They suggest a solution of the form:

$$\phi = f(r) \cos \theta$$

We plug into B.C.'s:

$$-\frac{1}{r} \frac{\partial \phi}{\partial \theta} \Big|_{r=0} = \frac{f}{r} \Big|_{r \rightarrow \infty} \sin \theta = U \sin \theta$$

$$\therefore \frac{f}{r} \Big|_{r \rightarrow \infty} = U$$

$$-\frac{\partial \phi}{\partial r} \Big|_{r \rightarrow \infty} = -f' \cos \theta = -U \cos \theta$$

$$\therefore f' \Big|_{r \rightarrow \infty} = U$$

Both are satisfied if

$$f \sim Ur \text{ as } r \rightarrow \infty$$

Plugging into $\nabla^2 \phi = 0$: (249)

$$\cos \theta f'' + \frac{\cos \theta}{r} f' - \frac{f}{r^2} \cos \theta = 0$$

$$\text{or } f'' + \frac{f'}{r} - \frac{f}{r^2} = 0$$

w/ B.C.'s:

$$f|_{r \rightarrow \infty} = 0; \quad f'|_{r=a} = 0$$

f is of the form:

$$f = r^n \quad \text{which yields:}$$

$$n(n-1) + n - 1 = 0$$

$$\text{or } (n+1)(n-1) = 0$$

$$\therefore n = 1, -1$$

$$f(r) = \frac{C_1}{r} + C_2 r$$

From condition as $r \rightarrow \infty$, $C_2 = 0$

250

At $r=a$ we have

$$f'|_{r=a} = \left[-\frac{C_1}{r^2} + U \right] \Big|_{r=a} = 0$$

$$\text{Thus } C_1 = Ua^2$$

And hence:

$$\phi = U \left(\frac{a^2}{r} + r \right) \cos \theta$$

This yields the velocity distribution:

$$u_\theta = -\frac{1}{r} \frac{\partial \phi}{\partial \theta} = U \left(1 + \frac{a^2}{r^2} \right) \sin \theta$$

$$u_r = -\frac{\partial \phi}{\partial r} = -U \left(1 - \frac{a^2}{r^2} \right) \cos \theta$$

A couple of things to note. First, $u_\theta|_{r=a} \neq 0$! Thus the tangential velocity violates the no-slip condition, as expected! This leads to the development of a very thin

(251)

boundary layer next to the surface where both viscosity and no-slip condition must apply! A Reynolds number based on the thickness of the boundary layer is of $O(1)$!

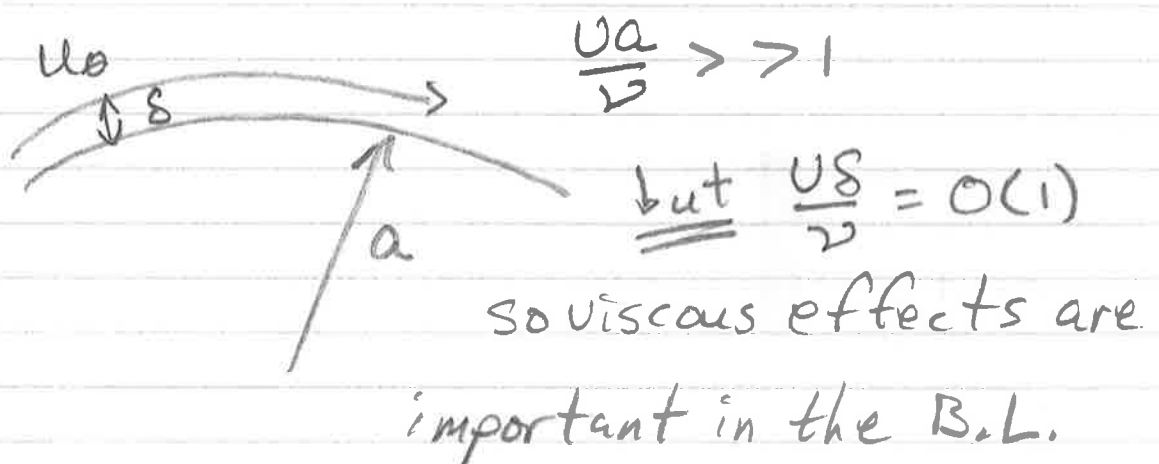

We'll look at B.L. problems in much more detail in a bit!

Second, $u_\theta|_{r=a} = 2U \sin\theta$, which

varies from zero at the leading and trailing stagnation points to twice the free stream velocity at

$\theta = \frac{\pi}{2}$! This means the fluid ²⁵² is accelerated going around the cylinder, and thus the pressure is lowest at $\theta = \frac{\pi}{2}$! Let's calculate this:

We have Bernoulli's eqⁿ:

$$\frac{1}{2} \rho u^2 + p + \rho g z = \text{const}$$

We neglect gravity! Far upstream we have $p = p_0$, $u = U$ on all streamlines. Thus:

$$\frac{1}{2} \rho u^2 + p = p_0 + \frac{1}{2} \rho U^2$$

at $r = a$ $u \equiv u_\theta$ ($u_r = 0$), thus:

$$p \Big|_{r=a} = p_0 + \frac{1}{2} \rho U^2 (1 - 4 \sin^2 \theta)$$

253

We can plot this up:

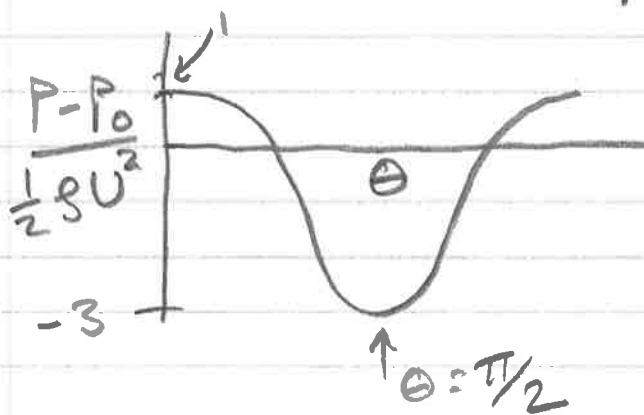

We can use this to calculate the drag ($\vec{F} \cdot \vec{e}_x$) on the cylinder!

There is no skin friction (no viscosity), thus:

$$\vec{F} = - \int_{\partial D} P \vec{n} dA$$

$$F_x = L \int_0^{2\pi} (-P) \vec{n} \cdot \hat{e}_x a d\theta$$

↑
length
of cylinder

$$= L \int_0^{2\pi} \frac{1}{2} \rho U^2 (1 - 4 \sin^2 \theta) \cos \theta d\theta = \underline{\underline{0}}$$

Thus the drag for ideal ²⁵⁴ potential
flow around a cylinder is zero!

This is known as D'Alembert's
Paradox, and arises because the
pressure distribution is symmetric -
there is high pressure on both the front
and back sides, which cancel out!

What really happens? \Rightarrow You don't
get pressure recovery on the back
side!

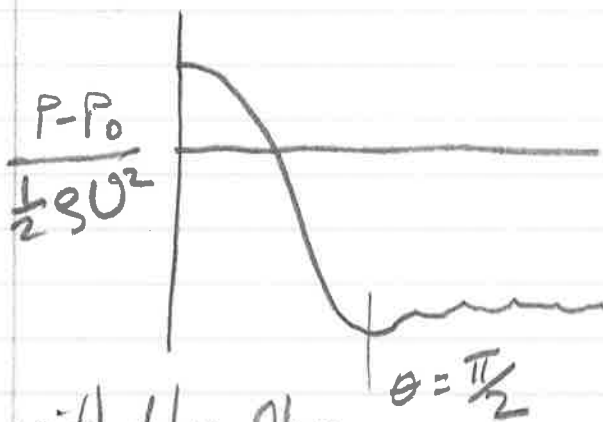

with the flow
field:



255

The Boundary Layer separates, & no longer is attached to the boundary!
This results in a much higher drag!
 \Rightarrow Separation is critical for high Re flows! Consider flow past a wing:

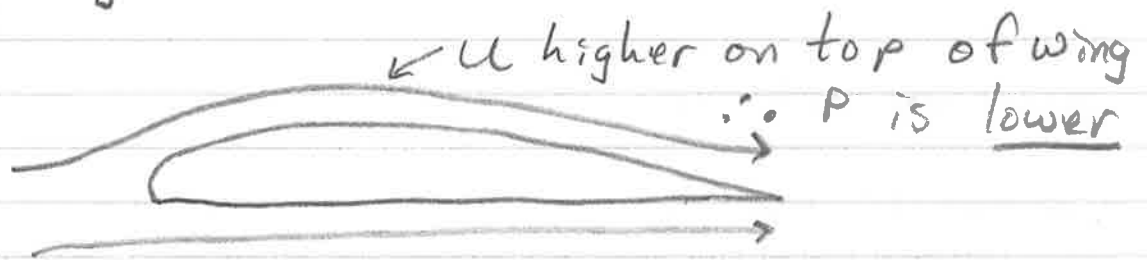

The ΔP from top to bottom provides Lift which makes the plane fly!

If there is no separation, the Drag is quite low! It's the Drag that the engines have to overcome to keep the plane moving! A commercial airliner has a max L/D ratio of ~ 20 !

256

What happens if the B.L. separates?

This will happen if the plane moves too slowly, or at too large an angle of attack:

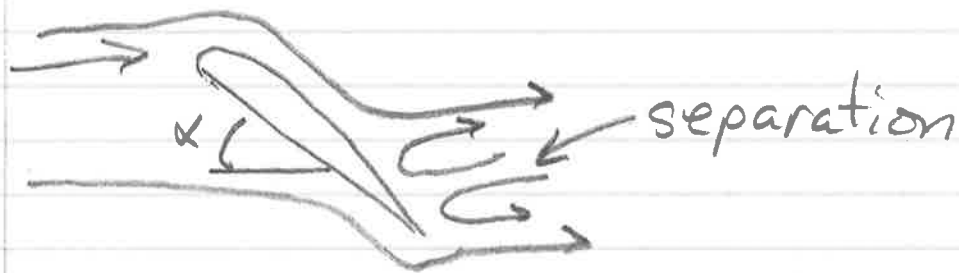

Separation does two things. First, it greatly increases drag, decreasing the L/D ratio and, since engines aren't designed to overcome this force, the plane slows down! Since $L \sim \rho U^2$, slowing down the plane kills the lift, and the plane falls! Second, wing control surfaces (e.g. elevators) are on the trailing edge of the wing. If the

257
flow separates, these surfaces
are now in a separation bubble
and can no longer control the motion
of the plane. This whole process is
called stall and a huge part of
wing design is figuring out how
to avoid it!

Boundary Layer Theory

(258)

The scaling of the N-S eq^{ns} at high Re suggests that viscous terms are unimportant on a length scale comparable to the size of a body. The Euler flow eq^{ns} which result require eliminating the no-slip condition! This leads to discontinuities in the velocity at the surface, thus viscous forces must be important in this region, termed the boundary layer: the region where inertia and viscosity are equally significant! We can determine the thickness of the B.L. & by rescaling the

N-S eqns in this region!

259

Let's look at a simple problem:
high Re flow past a plate of
length L at zero incidence (e.g.,
edge on into flow):

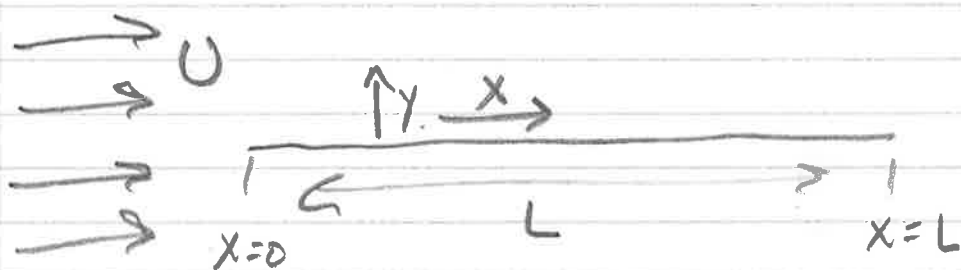

If we have $Re_L = \frac{UL}{\nu} \gg 1$

(Re_L = plate Reynolds #, based on length L)

we get the Euler flow eqns:

$$\frac{D\vec{u}}{Dt} = -\vec{\nabla} P \quad \left(+ \frac{1}{Re} \nabla^2 \vec{u} \right) \quad ; \quad \vec{\nabla} \cdot \vec{u} = 0$$

Small

The B.C. is just $\vec{u} \cdot \vec{n} \Big|_{y=0} = 0$ (no normal flow)

Because we've eliminated viscosity, we've
also eliminated the No-slip Condition!

(260)

Far from the plate ($y \rightarrow \infty$) we have the undisturbed flow:

$$\underline{u} \Big|_{y \rightarrow \infty} = U \hat{e}_x$$

This set of equations has the simple solution:

$$\underline{u} = U \hat{e}_x \quad \text{everywhere!}$$

But this leads to a step change in the velocity at $y=0$ (the plate).

Since viscous forces are proportional to velocity derivatives, they must become important in this region!

Suppose viscous forces are important over some region $y = O(\delta)$. We shall rescale the N-S equations to preserve the viscous term & the No Slip condition.

Let : $x^* = \frac{x}{L}$, $u^* = \frac{u}{U}$

$v^* = \frac{v}{V}$, $y^* = \frac{y}{\delta}$, $p^* = \frac{p - p_0}{\rho U^2}$

To determine δ & V we must look at the equations. First (always) we do the C.E.:

$$\frac{\partial u}{\partial x} + \frac{\partial v}{\partial y} = 0$$

$$\therefore \frac{U}{L} \frac{\partial u^*}{\partial x^*} + \frac{V}{\delta} \frac{\partial v^*}{\partial y^*} = 0$$

$$\text{or } \frac{\partial u^*}{\partial x^*} + \left(\frac{LV}{U\delta} \right) \frac{\partial v^*}{\partial y^*} = 0$$

Thus we require:

$$V = \frac{\delta}{L} U$$

Which is the same scaling we got in lubrication theory!

Now for the x-momentum eq'n:

$$\rho \left(\frac{\partial u}{\partial t} + u \frac{\partial u}{\partial x} + v \frac{\partial u}{\partial y} \right) = -\frac{\partial p}{\partial x} + \mu \left(\frac{\partial^2 u}{\partial x^2} + \frac{\partial^2 u}{\partial y^2} \right)$$

Let $t^* = Ut/L$, now we scale:

$$\rho \frac{U^2}{L} \left(\frac{\partial u^*}{\partial t^*} + u^* \frac{\partial u^*}{\partial x^*} + v^* \frac{\partial u^*}{\partial y^*} \right) = -\frac{\rho U^2}{L} \frac{\partial p^*}{\partial x^*} + \frac{\mu U}{\delta^2} \left(\frac{\partial^2 u^*}{\partial y^{*2}} + \frac{\delta^2}{L^2} \frac{\partial^2 u^*}{\partial x^{*2}} \right)$$

↑
↑
 inertial scaling for pressure dominant viscous term!

Dividing through:

$$\left(\frac{\partial u^*}{\partial t^*} + u^* \frac{\partial u^*}{\partial x^*} + v^* \frac{\partial u^*}{\partial y^*} \right) = -\frac{\partial p^*}{\partial x^*} + \frac{\mu L}{\rho U \delta^2} \left(\frac{\partial^2 u^*}{\partial y^{*2}} + \frac{\delta^2}{L^2} \frac{\partial^2 u^*}{\partial x^{*2}} \right)$$

We want to keep a viscous term!

Thus we require:

$$\frac{\mu L}{\rho U \delta^2} = 1 \quad \text{or} \quad \frac{\delta^2}{L^2} = \frac{\mu}{\rho U L} = \frac{1}{Re_L}$$

where $Re_L \equiv$ plate Reynolds number!

$$\text{So } \frac{\delta}{L} = \left(\frac{1}{Re_L} \right)^{1/2} \ll 1 \quad \text{for high } Re_L$$

and we get a boundary layer!

We thus have the Boundary Layer

Eg^s derived by Prandtl in 1904:

$$\frac{\partial u^*}{\partial x^*} + \frac{\partial v^*}{\partial y^*} = 0$$

$$\frac{\partial u^*}{\partial t^*} + u^* \frac{\partial u^*}{\partial x^*} + v^* \frac{\partial u^*}{\partial y^*} = -\frac{\partial p^*}{\partial x^*} + \frac{\partial^2 u^*}{\partial y^{*2}}$$

$$+ O\left(\frac{1}{Re_L}\right)$$

What about the pressure? small

We need another eqⁿ. Let's look

at the y -momentum eqⁿ:

$$\rho \left(\frac{\partial v}{\partial t} + u \frac{\partial v}{\partial x} + v \frac{\partial v}{\partial y} \right) = -\frac{\partial p}{\partial y} + \mu \left(\frac{\partial^2 v}{\partial x^2} + \frac{\partial^2 v}{\partial y^2} \right)$$

$$\frac{\rho U^2 \delta}{L^2} \left(\frac{\partial v^*}{\partial t^*} + u^* \frac{\partial v^*}{\partial x^*} + v^* \frac{\partial v^*}{\partial y^*} \right) = - \frac{\rho U^2}{\delta} \frac{\partial p^*}{\partial y^*} + \frac{\mu U}{\delta L} \left(\frac{\partial^2 v^*}{\partial y^{*2}} + \frac{\delta^2}{L^2} \frac{\partial^2 v^*}{\partial x^{*2}} \right)$$

Dividing through and rearranging:

$$\frac{\partial p^*}{\partial y^*} = - \frac{\delta^2}{L^2} \left(\frac{\partial v^*}{\partial t^*} + u^* \frac{\partial v^*}{\partial x^*} + v^* \frac{\partial v^*}{\partial y^*} \right) + \frac{1}{Re_L} \left(\frac{\partial^2 v^*}{\partial y^{*2}} + \frac{\delta^2}{L^2} \frac{\partial^2 v^*}{\partial x^{*2}} \right)$$

or:

$$\frac{\partial p^*}{\partial y^*} = O\left(\frac{1}{Re_L}\right)$$

small!

What does this mean?? Basically, a boundary layer is too thin to support a pressure gradient in the y-direction! The pressure distribution due to the external Euler (inviscid) flow is impressed on the boundary layer!

265

This applies equally well to other boundary layer problems, such as flow past a cylinder, etc. In these flows we take x to be the coordinate along the surface (e.g., $x \equiv a\theta$ for a cylinder of radius a) and y to be the coordinate normal to the surface (e.g., $y \equiv r - a$ for the same geometry):

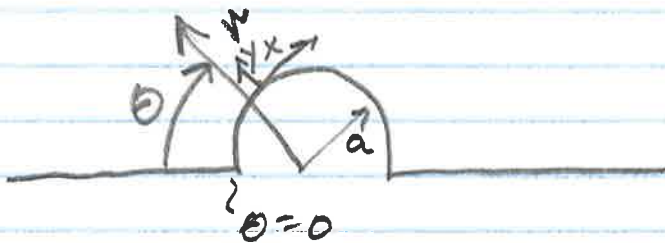

Ok, let's return to the flat plate problem. We have the B.L. eqns:

$$C.E.: \quad \frac{\partial u^*}{\partial x^*} + \frac{\partial v^*}{\partial y^*} = 0$$

(266)

X-mom:

$$\frac{\partial u^*}{\partial t^*} + u^* \frac{\partial u^*}{\partial x^*} + v^* \frac{\partial u^*}{\partial y^*} = -\frac{\partial P^*}{\partial x^*} + \frac{\partial^2 u^*}{\partial y^{*2}}$$

y-mom:

$$\frac{\partial P^*}{\partial y^*} = 0$$

Where we have ignored terms of $O(\frac{1}{Re_L})$.

The B.C.'s are:

$$u^* \Big|_{y^*=0} = v^* \Big|_{y^*=0} = 0 \quad (\text{no-slip})$$

$$P^* = P^* \Big|_{\frac{y}{L} \rightarrow 0}^{(EF)} \quad \begin{array}{l} \text{Euler flow solution} \\ \text{at } \frac{y}{L} = 0 \end{array}$$

$$u^* \Big|_{y^* \rightarrow \infty} = u^* \Big|_{\frac{y}{L} \rightarrow 0}^{(EF)} \quad \text{again, EF sol'n at the surface}$$

These latter matching conditions

work provided $\delta/L \ll 1$

Outer limit of BL \equiv Inner limit of EF

For the flat plate problem,

$$u^{*EF} = 1 \text{ (const)} \ \& \ P^{*EF} = 0$$

For steady state flow $\frac{\partial u^*}{\partial t^*} = 0$ so:

$$\frac{\partial u^*}{\partial x^*} + \frac{\partial v^*}{\partial y^*} = 0$$

$$u^* \frac{\partial u^*}{\partial x^*} + v^* \frac{\partial u^*}{\partial y^*} = \frac{\partial^2 u^*}{\partial y^{*2}}$$

$$u^* \Big|_{y^*=0} = v^* \Big|_{y^*=0} = 0 \quad u^* \Big|_{y^* \rightarrow \infty} = 1$$

How do we solve this set of eq'ns?

The flow is 2-D, so it is natural to define a stream function:

$$u^* = \frac{\partial \psi^*}{\partial y^*}, \quad v^* = -\frac{\partial \psi^*}{\partial x^*}$$

Substituting in:

$$\frac{\partial \psi^*}{\partial y^*} \frac{\partial^2 \psi^*}{\partial x^* \partial y^*} - \frac{\partial \psi^*}{\partial x^*} \frac{\partial^2 \psi^*}{\partial y^{*2}} = \frac{\partial^3 \psi^*}{\partial y^{*3}}$$

With B.C.'s:

$$\left. \frac{\partial \psi^*}{\partial x^*} \right|_{y^*=0} = \left. \frac{\partial \psi^*}{\partial y^*} \right|_{y^*=0} = 0; \quad \left. \frac{\partial \psi^*}{\partial y^*} \right|_{y^*=\infty} = 1$$

We still have a 3rd order non-linear PDE. What can we do with it??

This sort of problem often admits a similarity transform which allows us to convert a PDE to an ODE, a tremendous simplification! How do we know if this will happen? Apply Morgan's Theorem:

1) If a problem, including B.C.'s, is invariant to a one-parameter group of continuous transformations then the number of independent variables may be reduced by one.

2) The reduction is accomplished by choosing as new dependent and independent variables combinations which are invariant under the transformations.

The techniques for applying this theorem can be quite messy, but we'll stick to the simplest one: simple affine stretching.

Let's stretch all of the dep. & indep. variables! Let:

$$\psi^* = A\bar{\psi}, \quad x^* = B\bar{x}, \quad y^* = C\bar{y}$$

where A, B, C are a group of stretching parameters. If the problem can be made invariant while leaving one of these undetermined,

it will satisfy Morgan's Theorem! 270

Let's do this. Plugging in:

$$\frac{A^2}{BC^2} \left(\bar{\Psi}_{\bar{y}} \bar{\Psi}_{\bar{x}\bar{y}} - \bar{\Psi}_{\bar{x}} \bar{\Psi}_{\bar{y}\bar{y}} \right) = \frac{A}{C^3} \bar{\Psi}_{\bar{y}\bar{y}\bar{y}}$$

where subscripts denote derivatives.

Dividing thru:

$$\bar{\Psi}_{\bar{y}} \bar{\Psi}_{\bar{x}\bar{y}} - \bar{\Psi}_{\bar{x}} \bar{\Psi}_{\bar{y}\bar{y}} = \frac{B}{AC} \bar{\Psi}_{\bar{y}\bar{y}\bar{y}}$$

Thus the equation is invariant if $\frac{B}{AC} = 1$ (e.g., A, B & C disappear!)

We also have to look at the B.C.'s

$$\left. \frac{A}{B} \frac{\partial \bar{\Psi}}{\partial \bar{x}} \right|_{\bar{y}=0} = 0 \quad \Rightarrow \quad \left. \frac{\partial \bar{\Psi}}{\partial \bar{x}} \right|_{\bar{y}=0} = 0$$

(no restrictions)

Similarly,

$$\left. \frac{\partial \bar{\Psi}}{\partial \bar{y}} \right|_{\bar{y}=0} = 0$$

Now for the inhomogeneous B.C.: 271

$$\frac{A}{c} \frac{\partial \bar{\psi}}{\partial \bar{y}} \Big|_{c\bar{y}=\infty} = 1$$

Now $\frac{A}{c} = \infty$, so the location doesn't add a restriction, but we get:

$$\frac{\partial \bar{\psi}}{\partial \bar{y}} \Big|_{\bar{y}=\infty} = \frac{c}{A}$$

which is invariant only if $\frac{c}{A} = 1$

In general, homogeneous B.C.'s don't lead to restrictions on the stretching parameters, but in homogeneous ones do!

In this problem we only had two restrictions, but we had 3 parameters! Thus we satisfy Morgen's Theorem!

What will work? In general, any combination of variables which is invariant under the transformations will work, but some are better than others!!

For example, we have the transf:

$$\psi^* = A\bar{\psi}, \quad x^* = B\bar{x}, \quad y^* = C\bar{y}$$

and the restrictions:

$$\frac{B}{AC} = 1, \quad \frac{C}{A} = 1$$

Thus one possibility is:

$$\frac{x^*}{\psi^* y^*} = f(\zeta); \quad \zeta = \frac{y^*}{\psi^*}$$

which is clearly invariant! This would work, but would be extremely messy to use, with lots of implicit differentiation required! A better

(273)

choice is to recast the restrictions
so that the variable z only involves
in dependent variables!

We had:

$$\frac{B}{AC} = 1, \quad \frac{C}{A} = 1$$

A more convenient pair of restrictions
is obtained by division:

$$\frac{A}{C} = 1, \quad \frac{B}{C^2} = 1$$

which yields the transform:

$$\frac{y^*}{y^*} = f(z), \quad z = \frac{x^*}{y^{*2}}$$

This works better, but it's still
not the best choice! The problem
is that we are taking 3rd derivatives
with respect to y^* , but only 1st

274

derivatives w.r.t. x^* . It thus makes sense to put all the complexity in x^* :

$$\frac{A}{B^{1/2}} = 1, \quad \frac{C}{B^{1/2}} = 1$$

yields:

$$\frac{\psi^*}{(2x^*)^{1/2}} = f(\zeta); \quad \zeta = \frac{y^*}{(2x^*)^{1/2}}$$

(the factor of 2 in ζ and ψ are there for historical reasons - it gets rid of a constant in the transformed

DE - and has no significance! What matters is the dependence on y^* & x^* !)

This is known as Canonical Form:

Put all the complexity in the variable with the lowest highest derivative.

There can be exceptions to this for special problems, but it usually works pretty well!

OK, now let's get the transformed 275

ODE:

$$\frac{\partial \psi^*}{\partial y^*} = \frac{\partial (2x^*)^{1/2} f}{\partial y^*} = (2x^*)^{1/2} \frac{\partial f}{\partial z} \frac{\partial z}{\partial y^*}$$

$$\underline{\text{but}} \quad \frac{\partial z}{\partial y^*} = \frac{\partial}{\partial y^*} \left(\frac{y^*}{(2x^*)^{1/2}} \right) = \frac{1}{(2x^*)^{1/2}}$$

$$\text{so: } \frac{\partial \psi^*}{\partial y^*} = f' !$$

Similarly:

$$\frac{\partial^2 \psi^*}{\partial y^{*2}} = \frac{1}{(2x^*)^{1/2}} f''$$

$$\frac{\partial^3 \psi^*}{\partial y^{*3}} = \frac{1}{2x^*} f'''$$

These were simple, because we put all the complexity in x^* . Now we pay for it!

$$\frac{\partial \psi^*}{\partial x^*} = \frac{\partial}{\partial x^*} \left((2x^*)^{1/2} f \right) = \frac{1}{(2x^*)^{1/2}} f + (2x^*)^{1/2} f' \frac{\partial z}{\partial x^*}$$

But:

$$\frac{\partial \zeta}{\partial x^*} = \frac{\partial}{\partial x^*} \left(\frac{y^*}{(2x^*)^{1/2}} \right) = -\frac{1}{2} \frac{y^*}{x^* (2x^*)^{1/2}} = -\frac{1}{2} \frac{\zeta}{x^*}$$

Thus:

$$\frac{\partial \psi^*}{\partial x^*} = \frac{1}{(2x^*)^{1/2}} (f - \zeta f')$$

and finally:

$$\frac{\partial^2 \psi^*}{\partial x^* \partial y^{*2}} = \frac{\partial}{\partial x^*} (f') = -\frac{1}{2} \frac{\zeta}{x^*} f''$$

OK, now we plug back into the DE:

$$\frac{\partial \psi^*}{\partial y^*} \frac{\partial^2 \psi^*}{\partial x^* \partial y^{*2}} - \frac{\partial \psi^*}{\partial x^*} \frac{\partial^2 \psi^*}{\partial y^{*2}} = \frac{\partial^3 \psi^*}{\partial y^{*3}}$$

so:

$$-\frac{1}{2} \frac{\zeta}{x^*} f'' f' - \frac{1}{(2x^*)^{1/2}} (f - \zeta f') \frac{1}{(2x^*)^{1/2}} f'' = \frac{1}{2x^*} f'''$$

Which simplifies to:

$$f''' + f f'' = 0 !$$

This is known as the Blasius Equation for flow past a flat plate!

We also have the B.C.'s :

$$u^* \Big|_{y^*=0} = 0 \equiv \frac{\partial \psi^*}{\partial y^*} \Big|_{y^*=0} = f'(0)$$

$$\therefore f'(0) = 0$$

$$v^* \Big|_{y^*=0} = 0 \equiv -\frac{\partial \psi^*}{\partial x^*} \Big|_{y^*=0} = \frac{-1}{(2x^*)^{1/2}} (f - \beta f') \Big|_{z=0}$$

Now since $\beta f' \Big|_{z=0} = 0$ we get

$$f(0) = 0$$

Finally,

$$u^* \Big|_{y^* \rightarrow \infty} = 1 \equiv f'(\infty)$$

$$\therefore f'(\infty) = 1$$

So the complete problem reduces to the non-linear ODE:

$$u^* = \frac{\partial \psi^*}{\partial y^*} = f'(z)$$

$$v^* = -\frac{\partial \psi^*}{\partial x^*} = \frac{-1}{2x^{*1/2}} (f - \beta f')$$

where

$\psi = (2x^*)^{1/2} f(\zeta)$; $\zeta = \frac{y^*}{(2x^*)^{1/2}}$ (278)
 Similarity Rule Similarity Variable
 and:

$$f''' + ff'' = 0$$

$$f(0) = f'(0) = 0 \quad f'(\infty) = 1$$

What can we learn from all this?
 First, that the thickness of the boundary layer grows as $x^{*1/2}$. Since the profile is self-similar (same shape for all x), we approach the free stream velocity for some constant value of ζ . We expect, for example, that we reach 50% of the free stream velocity at some $\zeta = \zeta_{50\%} = O(1)$:

$$f'(\zeta_{50\%}) = \frac{1}{2} \quad (\text{free stream was } f' = 1)$$

To get the value of $\zeta_{50\%}$ we'd

(279)

have to solve the ODE, which can be done numerically, but we know $\zeta_{50\%}$ will be some $O(1)$ constant (the actual value is $\zeta_{50\%} = 1.096$).

What y value is this?

$$\zeta_{50\%} = \frac{y_{50\%}^*}{(2x^*)^{1/2}} = \frac{y_{50\%}}{\left(2\frac{2x}{U}\right)^{1/2}}$$

$$\text{Thus } y_{50\%} = \left(2\frac{2x}{U}\right)^{1/2} \zeta_{50\%}$$

So, within some $O(1)$ number, we reach 50% of the free stream velocity at $y \sim \left(\frac{2x}{U}\right)^{1/2}$ - and we get this without solving the equation!

What about the drag on the plate? Remember that we can break drag into two pieces:

which must be calculated numerically. 281
Doing this, we get $f''(0) = 0.4696$, so:

$$\tau_w = 0.332 \mu \left(\frac{U^3}{\nu x} \right)^{1/2}$$

We may define a local drag coefficient:

$$C_D^{(loc)} = \frac{\tau_w}{\frac{1}{2} \rho U^2}$$

↑ kinetic E/Vol
of flow

$$\text{So } C_D^{(loc)} = \frac{0.664}{\left(\frac{\rho U x}{\mu} \right)^{1/2}} \equiv \frac{0.664}{Re_x^{1/2}}$$

local plate Re

So the drag decreases as we move down the plate. This makes sense because the B.L. is getting thicker, so the shear rate is going down.

What is the total drag?

$$\frac{F}{\frac{1}{2} \rho U^2 \underbrace{LW}_{\text{area of plate}}} = \frac{1}{L} \int_0^L C_D^{(loc)} dx$$

$$= \frac{1}{L} \int_0^L \frac{0.664}{\left(\frac{\rho U}{\mu}\right)^{1/2}} x^{-1/2} dx = \frac{1.328}{Re_L^{1/2}}$$

$$\text{or } \frac{F}{\frac{1}{2} \rho U^2 LW} = \frac{2^{3/2} f''(0)}{Re_L^{1/2}}$$

In which we could have gotten everything to within some unknown $O(1)$ constant without having ever solved the ODE!

This is the power of both scaling analysis and similarity transforms.

The former tells you how a problem depends on the parameters involved, while the latter tells you alot about the functional form!

OK, for flow past a flat plate we had a uniform Euler Flow. What happens for a more complicated system?

Let's look at Stagnation Flow produced by a jet impinging on a surface (often used in cleaning).

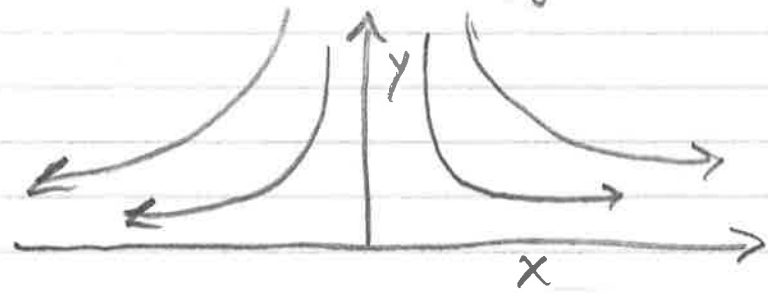

First we look at the Euler Flow: the flow is inviscid and irrotational,

so :

$$\vec{u} = -\nabla\phi, \quad \nabla^2\phi = 0$$

In this coordinate system we have

$$u = -\frac{\partial\phi}{\partial x}, \quad v = -\frac{\partial\phi}{\partial y}$$

With B.C.

$$v|_{y=0} = 0 \quad (\text{zero normal velocity})$$

(284)

Now for inviscid stagnation flow the solution is very simple:

$$u = \lambda x, \quad v = -\lambda y$$

which yields the potential:

$$\phi = -\frac{1}{2}\lambda(x^2 - y^2)$$

We will also need the pressure at the surface $y=0$. Let the pressure at the origin be p_0 .

Since the flow is inviscid we have Bernoulli's eq'n:

$$p + \frac{1}{2}\rho(\underline{u} \cdot \underline{u}) = \text{cst} \text{ along a streamline}$$

The surface $y=0$ is a streamline, and at $x=y=0$ the velocity vanishes

$$\text{Thus: } p \Big|_{y=0} = p_0 - \frac{1}{2}\rho u^2$$

All this is for Euler Flow. What about

the flow in the boundary layer?

We have the B.L. eqns:

$$u \frac{\partial u}{\partial x} + v \frac{\partial u}{\partial y} = -\frac{1}{\rho} \frac{\partial P}{\partial x} + \nu \frac{\partial^2 u}{\partial y^2}$$

where we have divided by ρ & dropped the $\frac{\partial^2 u}{\partial x^2}$ term. We also have the

B.C.'s:

$$u, v \Big|_{y=0} = 0 ; u \Big|_{y/\delta \rightarrow \infty} = u^{EF} \Big|_{y/L \rightarrow 0} = \lambda x$$

and P is given by Bernoulli's eqn outside the B.L.:

$$P + \frac{1}{2} \rho u^{(EF)2} = cst$$

$$\therefore \frac{\partial P}{\partial x} + \rho u^{EF} \frac{\partial u^{EF}}{\partial x} = 0$$

$$\text{or } \frac{1}{\rho} \frac{\partial P}{\partial x} = -\lambda^2 x \quad (\text{pressure decreases in } x\text{-direction})$$

so in the B.L.:

$$u \frac{\partial u}{\partial x} + v \frac{\partial u}{\partial y} = \lambda^2 x + \nu \frac{\partial^2 u}{\partial y^2}$$

Let: $x^* = \frac{x}{L}$, $y^* = \frac{y}{\delta}$, $u^* = \frac{u}{\lambda L}$, $v^* = \frac{v}{\lambda \delta}$

↳ driven by EF

Thus:

$$\frac{\lambda^2 L^2}{L} \left(u^* \frac{\partial u^*}{\partial x^*} + v^* \frac{\partial u^*}{\partial y^*} \right) = \lambda^2 L x^* + \frac{\nu \lambda L}{\delta^2} \frac{\partial^2 u^*}{\partial y^{*2}}$$

or:

$$u^* \frac{\partial u^*}{\partial x^*} + v^* \frac{\partial u^*}{\partial y^*} = x^* + \underbrace{\frac{\nu}{\lambda \delta^2}}_1 \frac{\partial^2 u^*}{\partial y^{*2}}$$

So $\delta = \left(\frac{\nu}{\lambda} \right)^{1/2}$ which is indep. of L!

Physically, the negative pressure gradient acts as a source of momentum in the B.L., which retards its growth!

$$\text{So: } u^* \frac{\partial u^*}{\partial x^*} + v^* \frac{\partial u^*}{\partial y^*} = x^* + \frac{\partial^2 u^*}{\partial y^{*2}}$$

$$u^* \Big|_{y^* \rightarrow \infty} = x^* \text{ (inner limit of EF)}$$

$$u^* \Big|_{y^*=0} = v^* \Big|_{y^*=0} = 0$$

We define the streamfunction ψ :

$$u^* = \frac{\partial \psi^*}{\partial y^*}, \quad v^* = -\frac{\partial \psi^*}{\partial x^*}$$

Thus:

$$\psi_{y^*}^* \psi_{x^* y^*}^* - \psi_{x^*}^* \psi_{y y^*}^* = x^* + \frac{\psi^*}{y y y^*}$$

$$\psi_{y^*}^* \Big|_{y^* \rightarrow \infty} = x^*, \quad \psi_{x^*}^* \Big|_{y^*=0} = \psi_{y^*}^* \Big|_{y^*=0} = 0$$

Let's look for a similarity transform!

$$\psi^* = A \bar{\psi}, \quad x^* = B \bar{x}, \quad y^* = C \bar{y}$$

So:

$$\frac{A^2}{B^2 C^2} \left[\bar{\psi}_{\bar{y}} \bar{\psi}_{\bar{x} \bar{y}} - \bar{\psi}_{\bar{x}} \bar{\psi}_{\bar{y} \bar{y}} \right] = B \bar{x} + \frac{A}{C^3} \frac{\bar{\psi}}{\bar{y} \bar{y} \bar{y}}$$

Dividing through by B:

$$\frac{A^2}{B^2 C^2} \left[\bar{\psi}_{\bar{y}} \bar{\psi}_{\bar{x} \bar{y}} - \bar{\psi}_{\bar{x}} \bar{\psi}_{\bar{y} \bar{y}} \right] = \bar{x} + \frac{A}{B C^3} \frac{\bar{\psi}}{\bar{y} \bar{y} \bar{y}}$$

Thus the DE is invariant if both

$$\frac{A^2}{B^2 C^2} = 1 \quad \text{and} \quad \frac{A}{B C^3} = 1$$

What about inhomogeneous B.C.? 288

$$\frac{A}{C} \frac{\partial \bar{\psi}}{\partial \bar{y}} \Big|_{\bar{y} \rightarrow 0} = B \bar{x}$$

or $\frac{A}{BC} = 1$ which is the same restriction as we already had!

So we only have 2 restrictions, and we'll get a similarity transform!

What is it?

$$\frac{A}{BC} = 1, \quad \frac{A}{BC^3} = 1 \quad \therefore \boxed{C = 1, \frac{A}{B} = 1}$$

Thus:

$$\frac{\psi^*}{x^*} = f(\zeta); \quad \zeta = \underline{\underline{y^*}}$$

ζ is not a function of x^* ! we could have guessed this because δ wasn't a function of L either!

So $\psi^* = x^* f(y^*)$

$\frac{\partial \psi^*}{\partial x^*} = f(y^*) ; \frac{\partial \psi^*}{\partial y^*} = x^* f'$, etc.

We get the transformed D.E.:

$(x^* f') (f') - (f) (x^* f'') = x^* + x^* f'''$

or, rearranging,

$f''' = f'^2 - f f'' - 1$

and $f(0) = f'(0) = 0, f'(\infty) = 1$

The shear stress (which is what leads to cleaning the surface!) is just:

$\tau_w = \mu \frac{\partial u}{\partial y} \Big|_{y=0} = \frac{\mu \lambda x}{\delta} f''(0)$

where $f''(0)$ is some constant!

It can be shown that any B.L. flow where $u \Big|_{\frac{y}{L} \rightarrow 0} \sim x^\alpha$ will admit a similarity solution!

290

OK, what about B.L. flows in more complex geometries? Consider a cylinder:

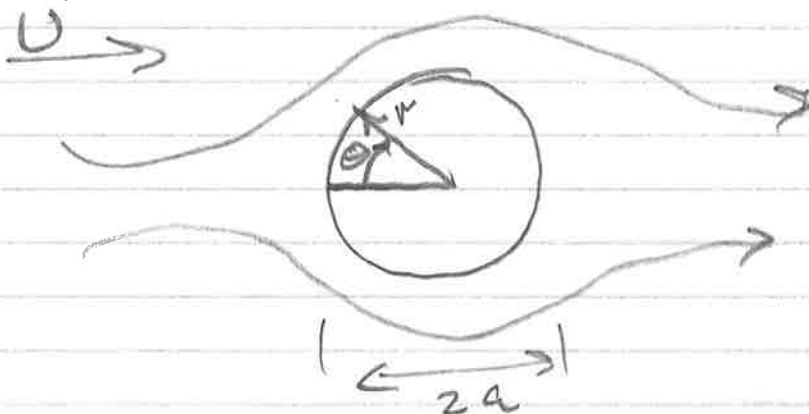

From Euler Flow equations, we have the pressure distribution:

$$(P - P_0)_{r=a} = \frac{1}{2} \rho U^2 (1 - 4 \sin^2 \theta)$$

To look at this problem, we define Boundary Layer coordinates: we let:

$x = \theta a$ (distance along bdy from leading stagnation point)

$y = r - a$ (distance normal to bdy)

291

Thus in the boundary layer:

$$\frac{\partial P}{\partial x} = \frac{1}{a} \frac{\partial}{\partial \theta} \left(P \Big|_{r=a}^{\text{EP}} \right) = -\frac{4\beta U^2}{a} \sin \theta \cos \theta$$

Thus for $0 < \theta < \frac{\pi}{2}$ the pressure gradient is negative. This means it is a source of momentum in the BL, and retards BL growth!

For $\theta > \frac{\pi}{2}$ we have $\frac{\partial P}{\partial x} > \underline{0}$, so it is a sink of momentum in the BL. This leads to rapid growth, and ultimately to BL separation!

To drive a BL against an adverse pressure gradient ($\frac{\partial P}{\partial x} > 0$) you have to get momentum in somehow. For laminar BL's this occurs only due to viscous diffusion ($\nu \frac{\partial^2 u}{\partial y^2}$), which is weak. A more efficient method

is by promoting turbulence, since (292) (as we'll see next lecture!) this leads to an eddy viscosity many times that of the molecular viscosity. This is done on airplane wings by vortex generators: tiny little fins that stick up out of the wing surface. These have the effect of increasing skin friction (which is small) but decreasing form drag by delaying or preventing separation.

Another example: baseballs! For a smooth sphere, the EF drag is zero because of complete pressure recovery on the back side! In practice, BL separation kills off the

recovery and leads to a drag which scales as :

$$F \sim C_D \left(\frac{1}{2} \rho U^2 \underbrace{\pi a^2}_{\substack{\text{cross-section} \\ \text{area}}} \right)$$

↳ inertial scaling for pressure

We can plot up C_D vs. Re :

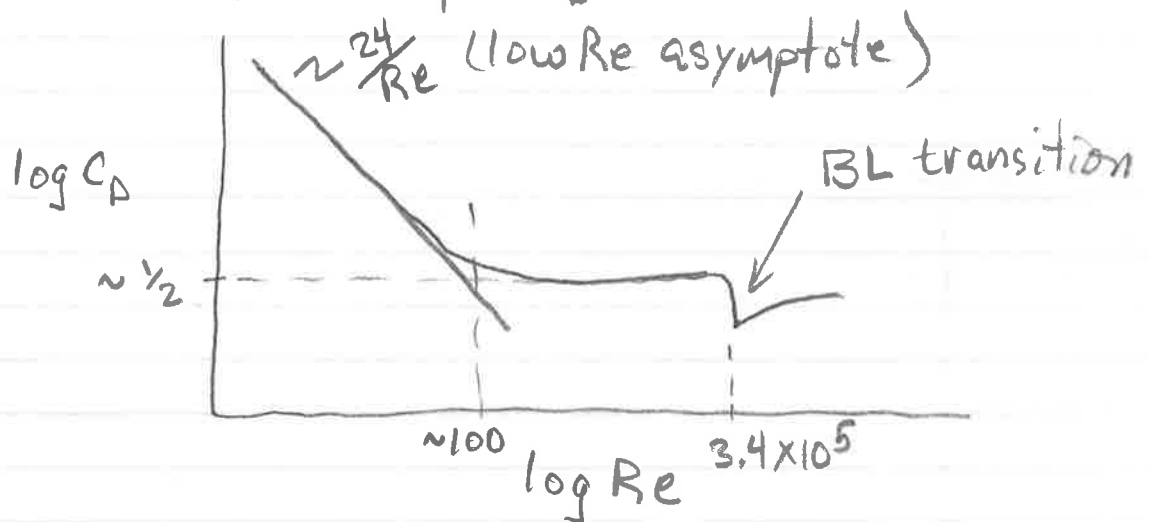

The abrupt transition at $Re \sim 3.4 \times 10^5$ results from the transition of the BL to turbulence, delaying separation, giving an increase in pressure recovery and reducing drag ~ 6 fold! On a baseball this transition is triggered at a lower Re

by the seams. If the ball ⁽²⁹⁴⁾ is thrown without rotation, it can cause it to dart sideways in an unpredictable manner due to recovery on one side, and not the other! (deflection of water too...)

What about boundary layer flow on a more complex shape such as a wing? Again, define boundary layer coordinates:

$x \equiv$ distance along surface from leading stagnation point

$y \equiv$ distance normal to surface

If $\delta/L \ll 1$ we may ignore curvature in the boundary layer! We thus get the B.L. eq^s in Cartesian coordinates:

$$u \frac{\partial u}{\partial x} + v \frac{\partial u}{\partial y} = -\frac{1}{\rho} \frac{\partial P}{\partial x} + \nu \frac{\partial^2 u}{\partial y^2}$$

where P is obtained from Bernoulli's eqⁿ applied to the Euler (inviscid) flow outside the B.L. Let u_0, P_0 be the velocity & pressure far upstream

and let u_∞ be the inner limit ⁽²⁹⁶⁾ of the EF solution (e.g., the EF velocity evaluated at the surface).

Thus:

$$P = P_0 + \frac{1}{2} \rho u_0^2 - \frac{1}{2} \rho u_\infty^2$$

and thus:

$$\frac{\partial P}{\partial x} = -\rho u_\infty \frac{\partial u_\infty}{\partial x}$$

We also have the B.C.'s:

$$u|_{y=0} = v|_{y=0} = 0, \quad u|_{y/\delta \rightarrow \infty} = u_\infty$$

and the C.E.:

$$\frac{\partial u}{\partial x} + \frac{\partial v}{\partial y} = 0$$

We may eliminate v by integrating over the B.L.:

$$v = - \int_0^y \frac{\partial u}{\partial x} dy \quad \text{since } v|_{y=0} = 0$$

Thus:

$$u \frac{\partial u}{\partial x} - \left(\int_0^y \frac{\partial u}{\partial x} dy \right) \frac{\partial u}{\partial y} = u_{\infty} \frac{du_{\infty}}{dx} + \nu \frac{\partial^2 u}{\partial y^2}$$

with B.C.'s:

$$u|_{y=0} = 0, \quad u|_{y/\delta \rightarrow \infty} = u_{\infty}$$

Even with knowledge of $u_{\infty}(x)$ (e.g., the EF solution) we still have to solve this numerically. For anything other than power law forms $u_{\infty} \sim x^{\alpha}$ we won't get a similarity solution either!

We can develop a more useful expression, known as the integral

BL eqn by integrating over the

BL thickness in the y -direction!

$$\int_0^{y/\delta \rightarrow \infty} \left\{ u \frac{\partial u}{\partial x} - \left(\int_0^y \frac{\partial u}{\partial x} dy \right) \frac{\partial u}{\partial y} - u_{\infty} \frac{du_{\infty}}{dx} \right\} dy = \int_0^{y/\delta \rightarrow \infty} \nu \frac{\partial^2 u}{\partial y^2} dy$$

Let's work on the LHS:

$$\text{LHS} = \int_0^{y/\delta \rightarrow \infty} \left\{ u \frac{\partial u}{\partial x} - u_{\infty} \frac{\partial u_{\infty}}{\partial x} \right\} dy - \int_0^{y/\delta \rightarrow \infty} \left(\int_0^y \frac{\partial u}{\partial x} dy \right) \frac{\partial u}{\partial y} dy$$

The second term may be integrated by parts to yield:

$$\begin{aligned} \text{LHS} &= \int_0^{y/\delta \rightarrow \infty} \left\{ u \frac{\partial u}{\partial x} - u_{\infty} \frac{\partial u_{\infty}}{\partial x} \right\} dy \\ &\quad - \left[u \int_0^y \frac{\partial u}{\partial x} dy \right]_0^{y/\delta \rightarrow \infty} + \int_0^{y/\delta \rightarrow \infty} u \frac{\partial u}{\partial x} dy \\ &= \int_0^{y/\delta \rightarrow \infty} \left\{ u \frac{\partial u}{\partial x} - u_{\infty} \frac{\partial u_{\infty}}{\partial x} \right\} dy \\ &\quad + \int_0^{y/\delta \rightarrow \infty} \left\{ u \frac{\partial u}{\partial x} - u_{\infty} \frac{\partial u_{\infty}}{\partial x} \right\} dy \end{aligned}$$

where we have made use of the

B.C. $u|_{y=0} = 0$ and that $u|_{y/\delta \rightarrow \infty} = u_{\infty}(x)$

which isn't a $f''(y)$ and can be pulled

(299)

inside the integral. The whole LHS

becomes:

$$\begin{aligned}
 \text{LHS} &= \int_0^{y/\delta \rightarrow \infty} \left\{ 2u \frac{\partial u}{\partial x} - u_{\infty} \frac{\partial u_{\infty}}{\partial x} - u_{\infty} \frac{\partial u}{\partial x} \right\} dy \\
 &= \int_0^{y/\delta \rightarrow \infty} \left\{ \frac{\partial u^2}{\partial x} - u_{\infty} \frac{\partial u_{\infty}}{\partial x} - \frac{\partial(u u_{\infty})}{\partial x} + u \frac{\partial u_{\infty}}{\partial x} \right\} dy \\
 &= \frac{d}{dx} \int_0^{y/\delta \rightarrow \infty} (u^2 - u u_{\infty}) dy + \frac{d u_{\infty}}{dx} \int_0^{y/\delta \rightarrow \infty} (u - u_{\infty}) dy
 \end{aligned}$$

$$\begin{aligned}
 &= \frac{d}{dx} \left\{ u_{\infty}^2 \int_0^{y/\delta \rightarrow \infty} \frac{u}{u_{\infty}} \left(1 - \frac{u}{u_{\infty}}\right) dy \right\} \\
 &\quad - u_{\infty} \frac{d u_{\infty}}{dx} \int_0^{y/\delta \rightarrow \infty} \left(1 - \frac{u}{u_{\infty}}\right) dy
 \end{aligned}$$

We thus define two integrals:

$$\delta^* \equiv \int_0^{y/\delta \rightarrow \infty} \left(1 - \frac{u}{u_{\infty}}\right) dy \equiv \text{displacement thickness}$$

$$\theta \equiv \int_0^{y/\delta \rightarrow \infty} \frac{u}{u_{\infty}} \left(1 - \frac{u}{u_{\infty}}\right) dy \equiv \text{momentum thickness}$$

Both have units of length. The

Displacement thickness is the distance streamlines outside the B.L. are deflected by the wedge of slow moving fluid in the boundary layer.

The ratio $H \equiv \delta^*/\theta$ is known as the shape factor and is a dimensionless measure of the shape of the B.L. velocity profile. For laminar flow past a flat plate:

$$H = \delta^*/\theta = 2.59$$

but this will change for $u_\infty \neq \text{cst}$, and if we have turbulent flow!

OK, what's all this good for? Let's look at the RHS:

$$\text{RHS} = \int_0^{y/\delta \rightarrow \infty} \nu \frac{\partial^2 u}{\partial y^2} dy = \frac{\mu}{\rho} \frac{\partial u}{\partial y} \Big|_0^{y/\delta \rightarrow \infty} = -\frac{1}{\rho} \mu \frac{\partial u}{\partial y} \Big|_{y=0}$$

But this is just the shear stress ⁽³⁰¹⁾ at the surface! $\tau_0 \equiv \mu \left. \frac{\partial u}{\partial y} \right|_{y=0}$

So:

$$\frac{\tau_0}{\rho} = \frac{d}{dx} \left(u_\infty^2 \Theta \right) + \delta^* u_\infty \frac{du_\infty}{dx}$$

which is known as the von Kármán boundary-layer momentum balance.

In general, it's very difficult to measure a velocity derivative $\frac{\partial u}{\partial y}$ at a surface, so instead we use integrals of u to get Θ & δ^* and then use these to calculate skin friction!

For our flat plate problem $u_\infty \equiv U$ (const), thus in this case:

$$\left. \frac{\tau_0}{\rho} \right| = U^2 \frac{d\Theta}{dx}$$

Blasius
problem

and the total drag is just:

302

$$F = w \int_0^L \tau_0 dx = w \rho U^2 \Theta \Big|_0^L$$

which is very convenient! This technique is used in Senior Lab.

So far we've focused on Laminar BL flows (although the von Kármán balance works pretty well in turbulent flow too). This is valid up to $Re_x \sim 3 \times 10^5$. Beyond this point life gets more complex:

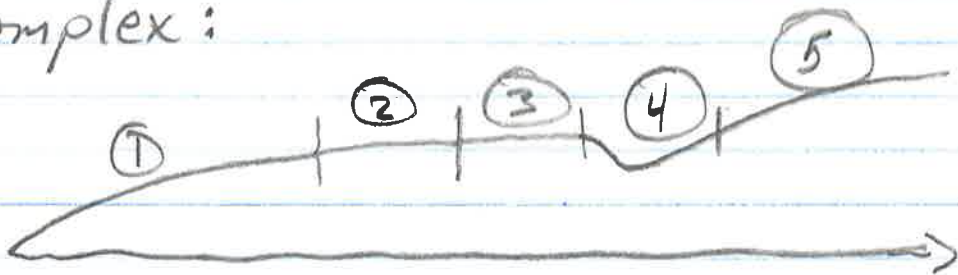

① Laminar flow^x (Blasius sol'n)

② Unstable laminar flow - 2-D

Tollmein-Schlichting waves which can

be predicted via an instability analysis

303

from the Navier-Stokes equations.

They look like this:



recirculation vortices
superimposed on mean flow

③ Unstable laminar flow: 3-D
waves and vortex formation

④ Bursting of vortices and growth
of fixed turbulent spots

⑤ Fully developed turbulent boundary
layer flow

which, like flow along a sufficiently
long flat plate, brings us to a
discussion of turbulence!

Friction Factors

How do you, as an engineer, determine ΔP and Q (flow rate) in a piping system? Such systems may be very complex networks, and the flow is usually turbulent. The easiest way is to use empirical friction factors!

Let's start with Dimensional Analysis:

$$\Delta P = f^n (\langle u \rangle, L, D, e, \mu, \rho)$$

where e is the surface roughness of a pipe. We can form the dimensional matrix:

	ΔP	$\langle u \rangle$	L	D	e	μ	ρ
M	1	0	0	0	0	1	1
L	-1	1	1	1	1	-1	-3
T	-2	-1	0	0	0	-1	0

The rank of this matrix is 3, thus

we get $7-3=4$ dimensionless groups! ⁽³¹⁷⁾

We can pick these a number of ways, but let's look for ones that make sense! We choose the aspect ratios:

$$\frac{L}{D}, \frac{e}{D}$$

And the Reynolds # $Re = \frac{\langle u \rangle D \rho}{\mu}$

The last one is the dimensionless pressure. Usually we're at high Re , so use inertial scaling:

$$\frac{\Delta P}{\rho \langle u \rangle^2} = f^{\#} \left(\frac{L}{D}, \frac{e}{D}, Re \right)$$

↳ known as the Euler #

It's actually more convenient to define a head loss

$$h_L \equiv \frac{\Delta P}{\rho g}$$

- the loss in hydrostatic head due to fluid friction!

Thus:

$$\frac{h_L}{(\langle u \rangle^2 / g)} = f^n \left(\frac{L}{D}, \frac{e}{D}, Re \right)$$

Empirically, we observe that for $L/D \gg 1$ we have $h_L \sim L$ (e.g., double the pipe length & you double the pressure drop).

Thus:

$$\frac{h_L}{\langle u \rangle^2 / g} = \frac{L}{D} f^n \left(\frac{e}{D}, Re \right)$$

We can define the Fanning Friction Factor

f_f s.t.

$$\frac{h_L}{(\langle u \rangle^2 / g)} = \frac{L}{D} (2 f_f)$$

where $f_f \equiv f^n \left(\frac{e}{D}, Re \right)$

If we determine f_f either theoretically or empirically, it's easy to get the head loss!

Let's look at low Re first. For 319 for laminar flow we get Poiseuille's Law:

$$\Delta P = 32 \frac{\mu \langle u \rangle L}{D^2}$$

Thus:

$$h_L \equiv \frac{\Delta P}{\rho g} = 32 \frac{\mu \langle u \rangle L}{\rho g D^2}$$

$$\text{or, } f_f = 16 \frac{\mu}{D \langle u \rangle \rho} \equiv \frac{16}{Re} !$$

Note that f_f is inversely proportional to Re as $Re \rightarrow 0$! This is because we've used inertial scalings for ΔP , whereas at low Re $\Delta P \sim \frac{\langle u \rangle \mu L}{D^2}$ (viscous scaling).

Empirically, for laminar flow f_f isn't a strong function of e/D provided $e/D \ll 1$. In fact, for $Re \rightarrow 0$ we can show that the correction is $O(e/D)$

320

using the Minimum Dissipation Theorem. This will not be true at higher Re , where even very small ϵ can play a big role by promoting turbulence!

Ok, how about turbulent flow?

We start with the Law of the wall obtained by Prandtl & von Kármán:

$$\bar{u}^+ \approx 2.5 \ln y^+ + 5.5 \quad \text{in the turbulent core}$$

\uparrow
 $\frac{1}{\kappa}, \kappa \approx 0.4$ (Kármán's value)

remember $\bar{u}^+ = \frac{\bar{u}}{(\frac{\tau_0}{\rho})^{1/2}}$ ← $V_* \equiv$ friction velocity

Let's assume that this applies throughout the pipe, and use it to calculate $\langle u \rangle$!

First, we need to relate y^+ to r :

$$y = R - r; \quad y^+ = \frac{(\frac{\tau_0}{\rho})^{1/2}}{v} y$$

So:

$$y^+ = \frac{(\tau_0/\rho)^{1/2}}{\nu} (R - r)$$

Now

$$\langle u \rangle = \frac{1}{\pi R^2} \int_0^R u \cdot 2\pi r \, dr$$

$$= \frac{2}{R^2} \int_0^R \left(\frac{\tau_0}{\rho} \right)^{1/2} \left(5.5 + 2.5 \ln \left(\frac{(\tau_0/\rho)^{1/2}}{\nu} (R - r) \right) \right) r \, dr$$

$$= \left(\frac{\tau_0}{\rho} \right)^{1/2} \left[2.5 \ln \left(\frac{R (\tau_0/\rho)^{1/2}}{\nu} \right) + 1.75 \right]$$

We need to relate τ_0 to ΔP . We do this with a force balance on the pipe:

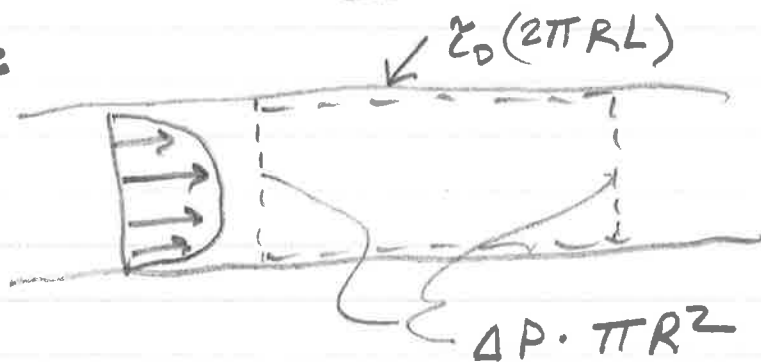

Forces must balance, so:

$$\tau_0 \underbrace{2\pi RL}_{\text{Area of wall}} = \Delta P \underbrace{\pi R^2}_{\text{x-section area}}$$

322

So
$$\frac{\Delta P}{L} = \frac{2\tau_0}{R}$$

which is valid at all $Re!$

Recall that
$$\Delta P \equiv 2 f_f \frac{L}{D} \rho \langle u \rangle^2$$

Thus
$$\frac{\langle u \rangle}{(\tau_0/\rho)^{1/2}} = \frac{1}{\sqrt{f_f/2}}$$

So:

$$\frac{1}{\sqrt{f_f/2}} = 2.5 \ln \left\{ \frac{R \langle u \rangle}{\nu} \sqrt{\frac{f_f}{2}} \right\} + 1.75$$

or, as is more usually expressed,

$$\frac{1}{\sqrt{f_f}} = 4.06 \log_{10} \left\{ Re \sqrt{f_f} \right\} - 0.40$$

as derived by von Kármán. We can

get a little better result by fitting

this model to empirical ΔP measurements!

If we take the constants as adjustable

parameters, we get:

$$\frac{1}{\sqrt{f_f}} = 4.0 \log_{10} \left\{ \text{Re} \sqrt{f_f} \right\} - 0.40$$

which is pretty close to what von Kármán's got from mixing-length theory! That was for smooth pipes ($e/D = 0$). For rough pipes, we get empirically:

$$\frac{1}{\sqrt{f_f}} = 4.0 \log_{10} \left(\frac{D}{e} \right) + 2.28$$

provided $\frac{e}{D} \gtrsim \frac{10}{\text{Re} \sqrt{f_f}}$

this makes more sense if we recall that

$$f_f = \frac{\tau_0}{\frac{1}{2} \rho \langle u \rangle^2} \text{ thus we get:}$$

$$\begin{aligned} \frac{e}{D} &\gtrsim \frac{10}{\text{Re} \sqrt{f_f}} = \frac{10}{\left(\frac{\rho \langle u \rangle D}{\nu} \right) \left(\frac{\tau_0}{\frac{1}{2} \rho \langle u \rangle^2} \right)^{1/2}} \\ &= \frac{10}{\sqrt{2}} \frac{\nu}{D} \left(\frac{\tau_0}{\rho} \right)^{1/2} \end{aligned}$$

or $e^+ \gtrsim 7 \Rightarrow$ e.g., when the wall roughness sticks up outside the

324

viscous sublayer!

Many plots of f_f vs Re & $\frac{e}{D}$ are available, but the most useful correlations are:

$$f_f = \frac{16}{Re}, \quad Re < 2100$$

$$f_f \approx \frac{0.0791}{Re^{1/4}}, \quad \frac{e}{D} = 0, \quad 3 \times 10^3 < Re < 10^5$$

$$\frac{1}{\sqrt{f_f}} = 4.0 \log_{10} \{ Re \sqrt{f_f} \} - 0.40, \quad Re > 3 \times 10^3, \quad \frac{e}{D} = 0$$

$$\frac{1}{\sqrt{f_f}} = 4.0 \log_{10} \left(\frac{D}{e} \right) + 2.28, \quad \frac{e}{D} \geq \frac{10}{Re \sqrt{f_f}}$$

In a pipe system we don't have just pipe, but we also have fittings! These also contribute to the head loss, we may define, for high Re flow, :

$$h_L = \frac{\Delta P}{\rho g} \equiv K \frac{\langle u \rangle^2}{2g}$$

where the "K" values are determined ³²⁵ empirically. A table of a few useful values is given below:

TABLE 14.1 FRICTION LOSS FACTORS FOR VARIOUS PIPE FITTINGS

Fitting	K	L_{eq}/D
Globe valve, wide open	7.5	350
Angle valve, wide open	3.8	170
Gate valve, wide open	0.15	7
Gate valve, $\frac{3}{4}$ open	0.85	40
Gate valve, $\frac{1}{2}$ open	4.4	200
Gate valve, $\frac{1}{4}$ open	20	900
Standard 90° elbow	0.7	32
Short-radius 90° elbow	0.9	41
Long-radius 90° elbow	0.4	20
Standard 45° elbow	0.35	15
Tee, through side outlet	1.5	67
Tee, straight through	0.4	20
180° Bend	1.6	75

(From Welty, Wicks & Wilson)

OK, how do we use all this? Just add up the head loss on any stream!

Consider the pump system:

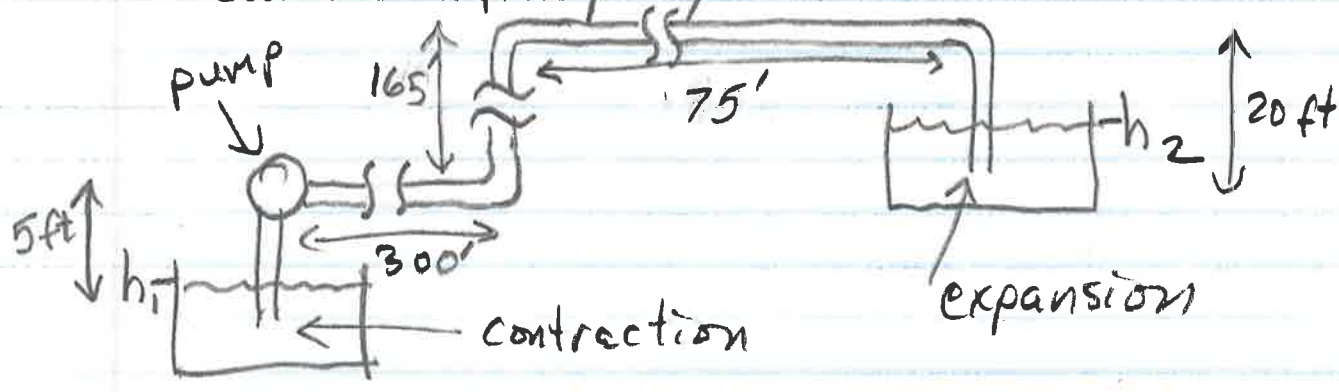

Suppose we have all 4" ID smooth pipe,
 and we want a flow rate $Q = 42 \text{ ft}^3/\text{min}$.
 What is the required power of the pump?

We have:

- 565' of 4" pipe
- 3 90° elbows
- 1 sudden contraction
- 1 sudden expansion

Change in
 Elevation: 150 ft

First we calculate the Re:

$$Re = \frac{\langle u \rangle D}{\nu} \quad \langle u \rangle = \frac{Q}{A} = \frac{42 \text{ ft}^3/\text{min}}{\pi (0.167 \text{ ft})^2}$$

$$= 8.0 \text{ ft/s}$$

$Re = 2.47 \times 10^5$ so flow is turbulent

For this Re, $f_f \approx 0.0038$

Thus for the pipes:

$$(h_L)_{\text{pipes}} = (2) (0.0038) \left(\frac{565'}{0.33'} \right) \frac{(8.0 \text{ ft/s})^2}{(32.2 \text{ ft/s}^2)}$$

$$= 25.4 \text{ ft which is nearly 1 atm!}$$

What about the fittings?

For a 90° elbow, we have $K \approx 0.7$

For a sudden contraction, we have

(in general):

$$K_{\text{contraction}} \approx 0.45 (1 - \beta)$$

where $\beta \equiv \frac{A_{\text{small}}}{A_{\text{large}}}$

Here $\beta = \underline{0}$ so $K_{\text{cont}} = 0.45$

For an expansion we have:

$$K_{\text{expansion}} = (1 - \beta)^2 = 1$$

(based on $\langle u \rangle$ in smaller pipe!)

Thus:

$$(h_L)_{\text{fittings}} = (3 \cdot (0.7) + 0.45 + 1) \frac{1}{2} \frac{(8.0)^2}{32.2}$$

$$= 3.6 \text{ ft}$$

OK, so what is the total head loss?

It's just the sum of the change in elevation, $(h_L)_{pipes}$ & $(h_L)_{fittings}$!

$$\Delta h = h_2 - h_1 + (h_L)_{pipes} + (h_L)_{fittings}$$

$$= 150' + 25.4' + 3.6' = \underline{179 \text{ ft}}$$

(Dominated by change in elevation)

What is the power requirement?

$$W = Q \Delta h \rho g = 7800 \text{ ft}^3/\text{s} = 14 \text{ hp}$$

So we need a pump output of 14 hp.

The input will be greater due to pump inefficiencies! What pump to use?

We look for a pump that puts out $42 \text{ ft}^3/\text{min} \approx 20 \text{ l/s}$ with a Δh of $179 \text{ ft} = 54.6 \text{ m}$

The pump curve of a pump which would do the job is on next page:



REVISION 1 2001-06
HIMAX

HH80

Auto Prime High Head Pump

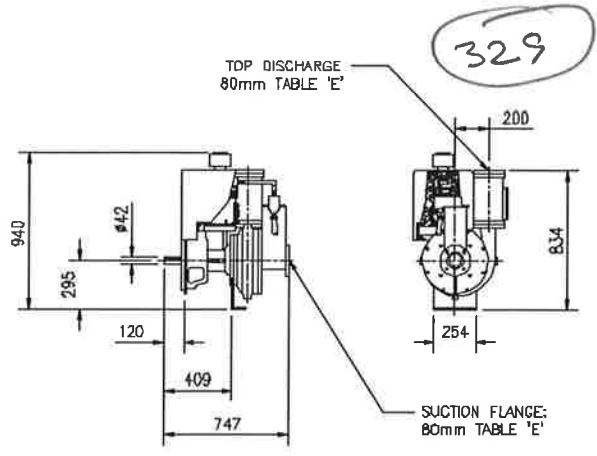

MATERIALS OF CONSTRUCTION:

Pump Casing:	S.G. IRON TO AS1831 GRADE 400/12
Suction Cover:	S.G. IRON TO AS1831 GRADE 400/12
Air Separation Tank:	S.G. IRON TO AS1831 GRADE 400/12
Bearing Bracket:	S.G. IRON TO AS1831 GRADE 400/12
Pump Shaft:	431 Stainless Steel
Impeller:	316 Stainless Steel
Wearplates:	316 Stainless Steel
Air Injector:	Brass Hard Nickel Plated
Seal Housing:	S.G. IRON TO AS1831 GRADE 400/12
Mechanical Seal:	Silicon Carbide / Silicon Carbide
Lip Seal:	Nitrile Rubber
N.R.V. Body:	Cast Iron AS 1830 GR T200
N.R.V. Seal & Ball:	Polyurethane
Compressor Details:	Bendix 2W 440 R Twin-in-line cylinders 75mm x 50mm stroke, air cooled 15cfm (410L/min) at 1000rpm, lubrication from engine oil system.

DESIGN DETAILS:

Pump Designation:	HH80
Pump Description:	Single stage, volute type, 3 bladed fully open Centrifugal pump
Suction Flange:	75mm Table 'D'
Delivery Flange:	75mm Table 'D'
Nominal Casing Thickness:	10mm
Nominal Shaft Diameter:	40mm
Impeller Eye Diameter:	90mm
Maximum Impeller O.D.:	325mm
Minimum Impeller O.D.:	230mm
Solids Handling Size:	25mm
Operating Speed:	MIN: 1200rpm MAX: 2200rpm
Maximum Head:	105 mtr
Maximum Flow:	100m ³ /hr

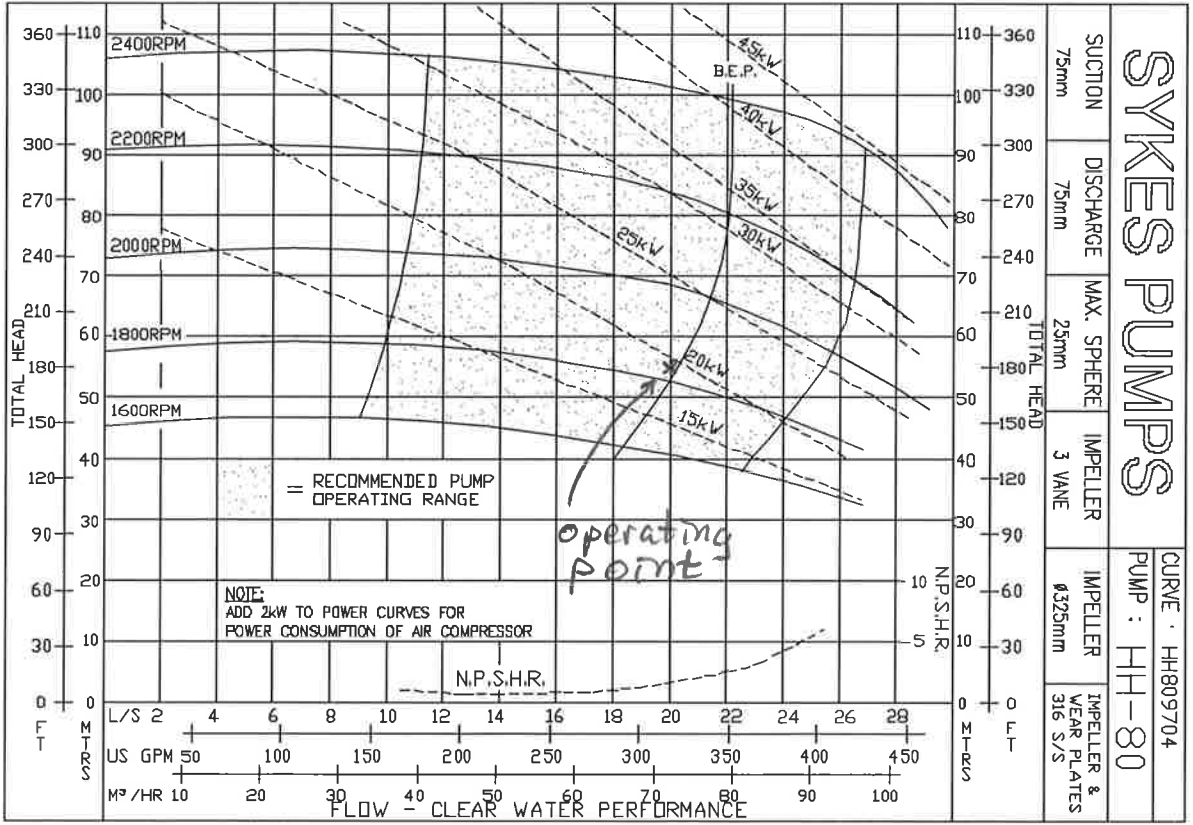

Website: www.sykespumps.com.au

Back to Main

The trick is to find a pump which can provide the required head (179 ft) and the desired flow rate (20 l/s), and where these values also lie in the recommended operating range of the pump! (shaded area). In this case, the HH80 pump operating at ~ 1820 RPM produces the required head & flow rate. What is the power consumption? This is given by the dashed curves. The consumption is ~ 19 kW (plus 2 kW for power consumption of air compressor as per footnote). What is the efficiency?

$$\text{Efficiency} = \frac{\text{work out}}{\text{work in}} = \frac{14 \text{ hp}}{21 \text{ kW}} = 0.50$$

$$(1 \text{ hp} = 0.746 \text{ kW})$$

or about 50% efficiency - not too bad!

331

Note that the operating point was close to the "BEP" curve \Rightarrow Best Efficiency Point! As you move away from this curve, the efficiency goes down! On the y-axis, the efficiency is zero \Rightarrow no flow means no work!

As a final note on pump curves, look at the "NPSHR" curve at the bottom. This is the "Net Positive Suction Head" Required at the pump inlet to prevent cavitation in the pump! For our system:

$$h_{\text{pump}} = 33.8 \text{ ft} - 5 \text{ ft} - 0.22 \text{ ft} - 0.46 \text{ ft}$$

\uparrow atm pressure \uparrow Δh elevation

$$= 26.1 \text{ ft} = 8.0 \text{ m}$$

\downarrow 5 ft of pipe contraction
 \downarrow $-\frac{\Delta P_{\text{vap}}}{\rho g}$ - $\frac{1}{2} \frac{\rho v^2}{\rho g}$
 \leftarrow vapor pressure (1.0 ft) \uparrow accel (1.02 ft)

This is greater than the NPSHR of about 2 m required at the operating condition (flow rate), so we're fine.

You often want to control output of a pump by throttling it with a valve. Always put the valve on the downstream side! Otherwise the $(h_L)_{\text{valve}}$ will reduce the NPSH at the pump inlet, and it will usually cavitate! This is very bad, because cavitation increases wear and can lead to the pump failing.

What about piping networks in a plant? It's easy to account for these using the head loss approach! Consider the reactor with recycle:

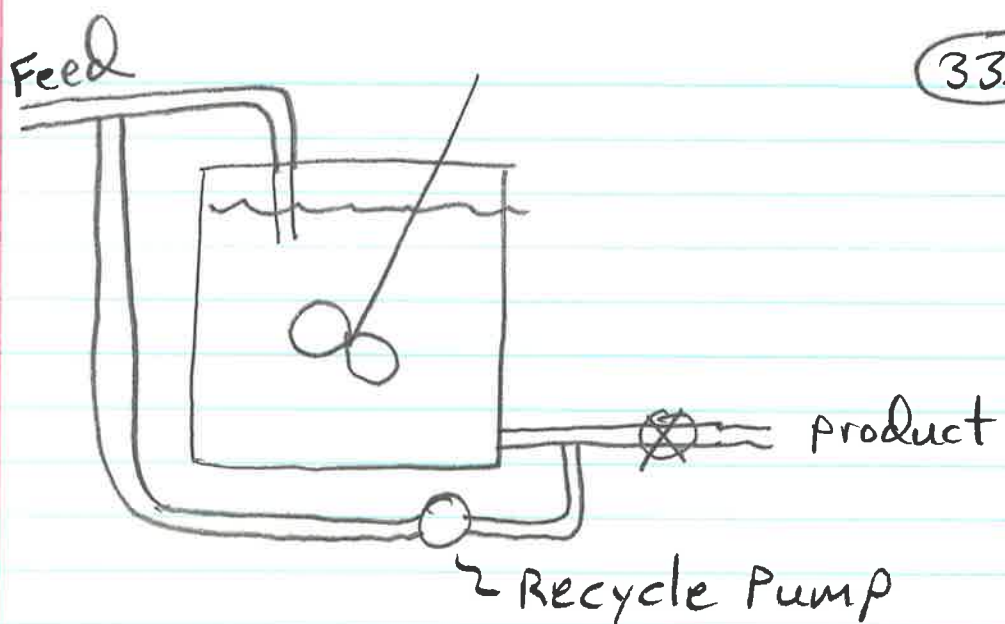

Suppose we want to size the pump for the recycle stream. We can represent the head losses & flow rates as an electrical network!

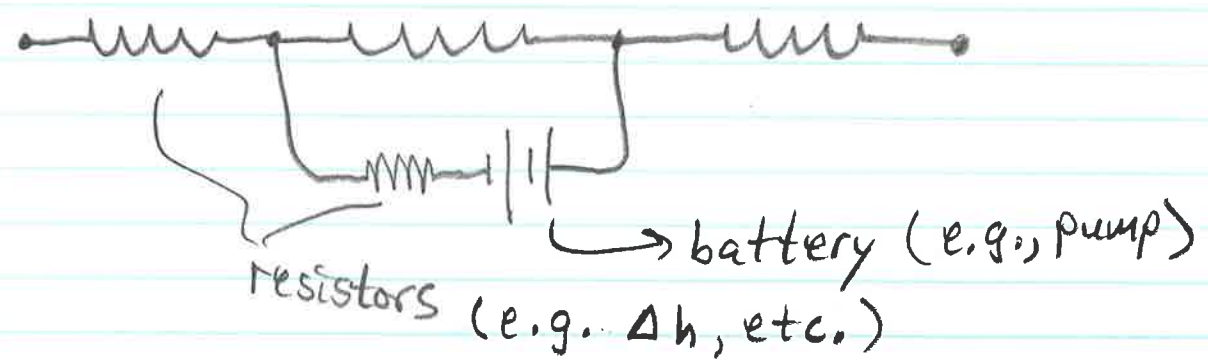

The head is equivalent to the voltage
 The flow rate is equivalent to the current. The only difference is that

Ohm's Law gets modified due to the non-linear dependence of h_L on Q !

As in circuits: The sum of the head loss along each possible fluid path from a common node to a common node must be the same!

Let's apply this:

First, label the streams:

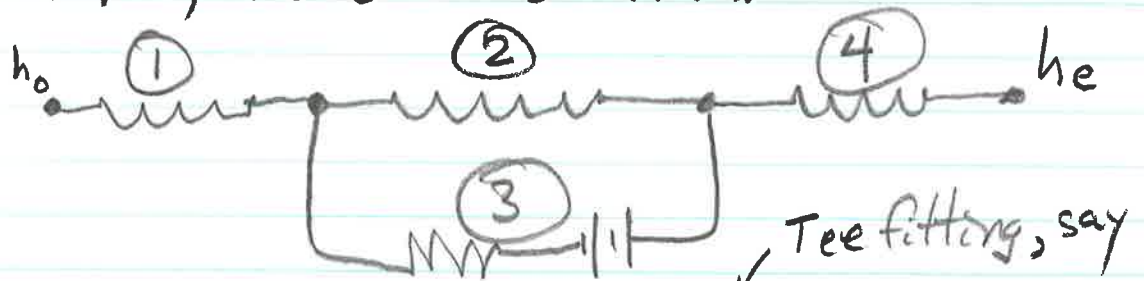

$$h_L^{(1)} = \left[\left(2 f_f^{(1)} \frac{L^{(1)}}{D} \frac{1}{g} \right) + \frac{0.4}{2g} \right] \left(\frac{Q_1}{A_1} \right)^2$$

$$h_L^{(2)} = \left[\left(2 f_f^{(2)} \frac{L^{(2)}}{D} \frac{1}{g} \right) + \frac{\sum K^{(2)}}{2g} \right] \left(\frac{Q_2}{A_2} \right)^2 + \Delta h^{(2)}$$

$$h_L^{(3)} = \left[\left(2 f_f^{(3)} \frac{L^{(3)}}{D} \frac{1}{g} \right) + \frac{\sum K^{(3)}}{2g} \right] \left(\frac{Q_3}{A_3} \right)^2 + \Delta h^{(3)} - \Delta h_{\text{pump}}$$

$$h_L^{(4)} = \left[\left(2 f_f^{(4)} \frac{L^{(4)}}{D} \frac{1}{g} \right) + \frac{\sum K^{(4)}}{2g} \right] \left(\frac{Q_4}{A_4} \right)^2$$

335

We combine these definitions with mass and head loss balances:

$$h_o - h_L^{(1)} - h_L^{(2)} - h_L^{(4)} = h_e$$

$$h_L^{(2)} = -h_L^{(3)}$$

$$Q_1 = Q_4 \quad Q_2 = Q_1 + Q_3$$

If we specify, say, Q_1 and the recycle ratio Q_3/Q_2 we could calculate both the total head loss through the system $h_o - h_e$ and the required pump head Δh_{pump} . Note that this is a system of non-linear equations, but it's easy to solve it numerically!

How To Size A Pump

- 1) Remember Bernoulli's Equation!
- 2) Losses are proportional to $\frac{1}{2} \rho U^2$

OK, If we know the flow rate and the pipe diameter, it's easy!

$$1) \quad U = \frac{Q}{A} = \frac{Q}{\frac{\pi D^2}{4}}$$

$$2) \quad Re = \frac{UD}{\nu}$$

- 3) we need the total head required of the pump:

$$P_T = \rho g \Delta h + \frac{1}{2} \rho U^2 \left[1 + 4f_f \frac{L}{D} + \sum K \right]$$

↑ ↑ ↑ ↑
 change in elevation acceleration of fluid pipe losses fitting losses

- 4) To get pipe losses:

a) Determine L/D

(2)

b) Get f_f .

If $Re < 10^5$ we have:

$$f_f \approx \frac{0.0791}{Re^{1/4}}$$

If $Re > 10^5$:

$$f_f \approx \left(4.0 \log_{10} \{ Re \sqrt{f_f} \} - 0.40 \right)^{-2}$$

Usually one iteration is good enough!

If the pipe is rough use:

$$f_f \approx \left(4.0 \log_{10} \left(\frac{D}{e} \right) + 2.28 \right)^{-2} ; \frac{e}{D} > \frac{10}{Re \sqrt{f_f}}$$

5) Count up all the fitting K values

\Rightarrow If you have a final "expansion", that's just the "1" for fluid acceleration, so don't double count it

6) The head is just $h_T = \frac{P_T}{\rho g}$ - so find

the Q, h_T operating point on the pump curve!

How To Size A Pipe

1) Determine the driving force.

(available pressure, or Δh for gravity fed flow)

2) Apply Bernoulli's eq'n (w/ losses!)

For gravity fed flows:

$$g \Delta h = \frac{1}{2} \rho \left(\frac{Q}{A} \right)^2 \left[1 + 4 f_f \frac{L}{D} + \sum K \right]$$

Annotations for the equation above:

- $g \Delta h$: head to drive flow
- $\frac{Q}{A}$: velocity
- $4 f_f \frac{L}{D}$: pipe losses
- $\sum K$: fitting losses

$$A = \frac{\pi D^2}{4}, \quad Re = \frac{UD}{\nu}$$

3) This is solved iteratively!

$$D = \left\{ \frac{8Q^2 \left[1 + 4 f_f \frac{L}{D} + \sum K \right]}{\pi^2 g \Delta h} \right\}^{1/4}$$

=> Guess some D, calc U & Re & f_f

=> Get a better guess for D from above relation & iterate!

How to Determine a Flow Rate

- 1) Determine the driving force
- 2) Use Bernoulli's Eq'n (with losses!)

$$\Delta P_T = \rho g \Delta h + \frac{1}{2} \rho \left(\frac{Q}{A} \right)^2 \left[1 + 4f_f \frac{L}{D} + \sum k \right]$$

↑ total head to drive flow ↑ change in elevation ↑ pipe area ↑ acceleration ↑ very weak function of Q/A ↑ fitting

- 3) Solve for Q ! (Iterate to get correct f_f)
 ↳ guess $f_f \approx 0.004$ to start (a typical value)

4) If we don't know ΔP_T , but know the power, we use:

$$\text{Power} = \Delta P_T Q = Q \left(\rho g \Delta h + \frac{1}{2} \rho \left(\frac{Q}{A} \right)^2 \left[1 + 4f_f \frac{L}{D} + \sum k \right] \right)$$

and again iterate...

Turbulence

Turbulent flow is chaotic and time dependent, so it is difficult to describe directly using the N-S equations. Instead, we look at the time-average of the motion!

$$\text{Let } \underline{u} = \bar{\underline{u}} + \underline{u}'$$

$$\text{where } \bar{\underline{u}} \equiv \frac{1}{\delta t} \int_t^{t+\delta t} \underline{u} \, dt$$

e.g., we average \underline{u} over some small interval of time. By definition, then, fluctuations average out:

$$\frac{1}{\delta t} \int_t^{t+\delta t} \underline{u}' \, dt \equiv \underline{\underline{0}}$$

The objective is to develop a set of averaged equations for $\bar{\underline{u}}, \bar{P}$!

First, we look at the C.E. ϵ

$$\nabla \cdot \underline{u} = 0$$

$$\frac{1}{\delta t} \int_t^{t+\delta t} (\nabla \cdot \underline{u}) dt = \nabla \cdot \left\{ \frac{1}{\delta t} \int_t^{t+\delta t} \underline{u} dt \right\} \equiv \nabla \cdot \bar{\underline{u}}$$

In general, the linear terms don't give us any trouble! It's the non-linear ones that cause problems!

Let's look at the N-S eq^{ns}:

$$\rho \frac{\partial \underline{u}}{\partial t} + \rho \underline{u} \cdot \nabla \underline{u} = -\nabla p + \mu \nabla^2 \underline{u}$$

Let's time average each term:

$$\frac{1}{\delta t} \int_t^{t+\delta t} \rho \frac{\partial \underline{u}}{\partial t} dt = \frac{\rho}{\delta t} \left[\underline{u}(t) \right]_t^{t+\delta t}$$

$$= \rho \frac{\bar{\underline{u}}(t+\delta t) - \bar{\underline{u}}(t)}{\delta t} + \rho \frac{\underline{u}'(t+\delta t) - \underline{u}'(t)}{\delta t}$$

Now the second term may be non-zero, but it will have zero mean on average and

(306)

shouldn't contribute to the flow. If the time scale for turb. fluctuations is short with respect to the time scale for mean variations (e.g., the time scale of increasing or decreasing flow rates through a pipe) then the first term reduces to:

$$\frac{1}{\delta t} \rho [\bar{u}(t+\delta t) - \bar{u}(t)] \approx \rho \frac{\partial \bar{u}}{\partial t}$$

Next look at pressure:

$$\frac{1}{\delta t} \int_t^{t+\delta t} \nabla \cdot \underline{p} \, dt \approx \nabla \cdot \bar{p}$$

and the viscosity term:

$$\frac{1}{\delta t} \int_t^{t+\delta t} \mu \nabla^2 \underline{u} \, dt = \mu \nabla^2 \bar{\underline{u}}$$

So the linear terms didn't cause any trouble. Now for the non-linear

convection term:

$$\begin{aligned}
 \frac{1}{\delta t} \int_t^{t+\delta t} \rho \underline{u} \cdot \nabla \underline{u} \, dt &= \frac{\rho}{\delta t} \int_t^{t+\delta t} (\bar{\underline{u}} + \underline{u}') \cdot \nabla (\bar{\underline{u}} + \underline{u}') \, dt \\
 &= \frac{\rho}{\delta t} \int_t^{t+\delta t} \left[\bar{\underline{u}} \cdot \nabla \bar{\underline{u}} + \bar{\underline{u}} \cdot \nabla \underline{u}' + \underline{u}' \cdot \nabla \bar{\underline{u}} + \underline{u}' \cdot \nabla \underline{u}' \right] dt \\
 &= \rho \bar{\underline{u}} \cdot \nabla \bar{\underline{u}} + \rho \underbrace{\frac{1}{\delta t} \int_t^{t+\delta t} \underline{u}' \cdot \nabla \underline{u}' \, dt}_{\text{non-zero!}}
 \end{aligned}$$

avg to zero!

Let's write this as

$$\rho \langle \underline{u}' \cdot \nabla \underline{u}' \rangle \equiv \nabla \cdot \langle \rho \underline{u}' \underline{u}' \rangle$$

for $\rho = \text{cst}$ (and $\nabla \cdot \underline{u}' = 0$) where $\langle \rangle$

denote time averaging

Thus we get the time-averaged eqns:

$$\rho \frac{\partial \bar{\underline{u}}}{\partial t} + \rho \bar{\underline{u}} \cdot \nabla \bar{\underline{u}} = -\nabla \bar{p} + \mu \nabla^2 \bar{\underline{u}} - \nabla \cdot \langle \rho \underline{u}' \underline{u}' \rangle$$

This last term may be written as:

308

$$-\nabla \cdot (\langle \underline{\underline{su'u'}} \rangle) \equiv \nabla \cdot \underline{\underline{\tau}}^{\text{turb}}$$

where $\underline{\underline{\tau}}^{\text{turb}} \equiv -\langle \underline{\underline{su'u'}} \rangle \equiv \text{Reynolds Stress}$

It's the added momentum flux due to turbulent fluctuations!

To solve these equations we need a way of modelling $\underline{\underline{\tau}}^{\text{turb}}$ in terms of velocity gradients, much like Newton's Law of Viscosity for laminar stresses! Unfortunately, this is hard to do, and only approximate models exist!

Let's look at the simplest model:

Prandtl mixing length theory

In gases, mass, momentum & energy transport rates are calculated by looking at the rate with which molecules

cross streamlines \Rightarrow since they physically carry momentum, mass & energy, if they cross streamlines you get a flux of these quantities! You can use this to estimate the viscosity of a gas, for example!

In turbulence, Prandtl's idea was that eddies do the same thing! As two eddies exchange places (across streamlines) they also lead to momentum transfer (e.g., the Reynolds stress). In a channel, these arguments lead to:

$$\overline{\tau}_{yx}^{\text{turb}} = \left\{ \rho l^2 \left| \frac{\partial u}{\partial y} \right| \right\} \frac{\partial u}{\partial y}$$

$\underbrace{\hspace{10em}}_{\rightarrow \overline{\mu}^t}$

The quantity above is the eddy viscosity

by analogy with Newton's law of viscosity! The quantity " l " is the length scale of the eddies, and the shear rate $|\frac{du}{dy}|$ is the rate with which such exchanges take place!

Prandtl made the further approximation: Eddies are bigger in the middle of a pipe than near the wall, so let:

$$l \equiv \alpha y$$

where the wall is at $y=0$. This const. α is known as the von Kármán const, and is about $\alpha = 0.36$ by fitting to empirical data!

OK, now let's apply this to flow near a wall. If the shear stress

is constant, we get:

$$\bar{\tau}_{yx} = \tau_0 = \bar{\tau}_{yx}^{\text{laminar}} + \bar{\tau}_{yx}^{\text{turb}}$$

In general, $\bar{\tau}_{yx}^t \gg \bar{\tau}_{yx}^l$ (about 100x!)

so we'll ignore the laminar contrib.

We find, empirically, the following picture:

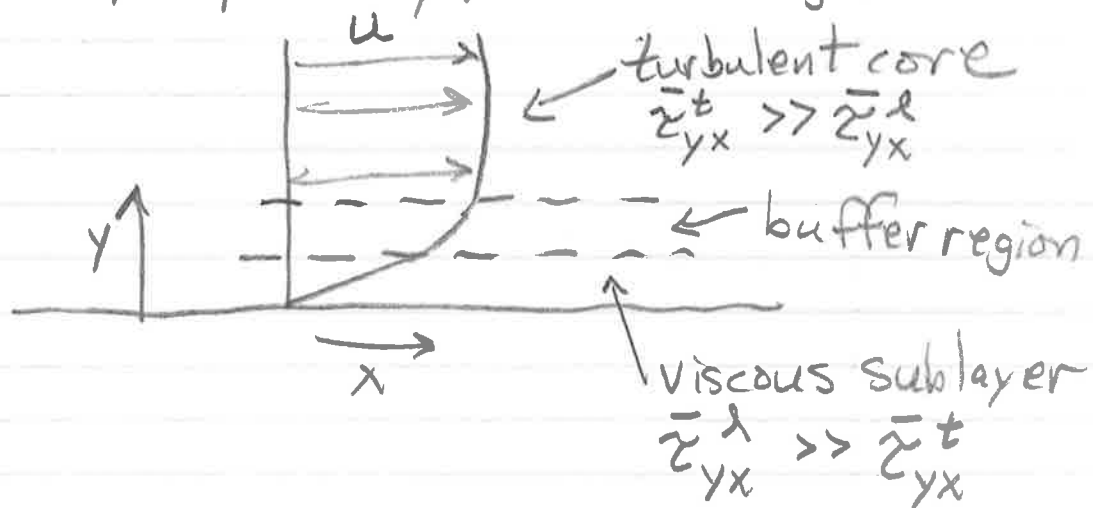

In the turbulent core:

$$\tau_0 \approx \rho \alpha^2 y^2 \left| \frac{\partial \bar{u}}{\partial y} \right| \frac{\partial \bar{u}}{\partial y}$$

So:

$$\frac{\partial \bar{u}}{\partial y} = \frac{1}{y} \frac{1}{\alpha} \left(\frac{\tau_0}{\rho} \right)^{1/2}$$

Let's render this dimensionless! The scaling for velocity is the

Friction velocity $v_* \equiv \left(\frac{\tau_0}{\rho}\right)^{1/2}$ (312)

The scaling for y is the viscous length

$$\text{scale} \equiv \frac{\nu}{\left(\frac{\tau_0}{\rho}\right)^{1/2}}$$

We thus define scaled coordinates:

$$\bar{u}^+ = \frac{\bar{u}}{\left(\frac{\tau_0}{\rho}\right)^{1/2}} \quad y^+ = \frac{y}{\frac{\nu}{\left(\frac{\tau_0}{\rho}\right)^{1/2}}}$$

So:

$$\frac{\partial \bar{u}^+}{\partial y^+} = \frac{1}{\alpha} \frac{1}{y^+}$$

$$\text{and } \bar{u}^+ = \frac{1}{\alpha} \ln y^+ + c$$

or the velocity profile should be logarithmic

near the wall! The constants α and c

are obtained by fitting the model to

the data. For flow through tubes we

get $\alpha \approx 0.36$, $c \approx 3.8$ for $y^+ \geq 26$

(e.g., $y^+ \approx 26$ is the edge of the turbulent

core). This works for $Re \geq 20,000$ in smooth pipes. For $y^+ < 26$ you need to use other correlations which include $\bar{\tau}_{yx}^R$ (e.g., viscosity). For very small y^+ (e.g., $y^+ \leq 5$) we may ignore $\bar{\tau}_{yx}^t$ rather than $\bar{\tau}_{yx}^R$! This is the viscous sublayer, which yields:

$$\bar{u}^+ = y^+ \quad 0 < y^+ \leq 5$$

So we get:

$$\bar{u}^+ = \begin{cases} y^+ & 0 < y^+ < 5 \\ \frac{1}{0.36} \ln y^+ + 3.8 & y^+ \geq 26 \end{cases}$$

and a more complicated expression in the buffer region $5 \leq y^+ \leq 26$

What are the physical dimensions of the friction velocity and viscous length scale?

Suppose we are pumping water through a 4" (10 cm) dia pipe at $\langle u \rangle = 1 \text{ m/s}$.
($\approx 2 \text{ gal/s}$)

We have:

$$Re = \frac{\langle u \rangle D}{\nu} \approx 10^5$$

At this Re we are well into the turbulent regime! Empirical correlations suggest that for $2.1 \times 10^3 < Re < 10^5$ the wall shear stress is about:

$$\frac{\tau_0}{\frac{1}{2} \rho \langle u \rangle^2} \approx \frac{0.0791}{Re^{1/4}}$$

Thus $\tau_0 \approx 22 \text{ dyne/cm}^2$ - about 27 x greater than would be the case for laminar flow! We thus get the friction velocity $V_* = \left(\frac{\tau_0}{\rho}\right)^{1/2} = 4.7 \text{ cm/s}$ and the viscous length:

$$\frac{\nu}{V_*} = 0.002 \text{ cm} = 20 \mu\text{m}!$$

Thus since we reach the turbulent core only 520 μm from the wall, virtually the entire tube is turbulent!

In general, for smooth tubes:

$$\frac{\nu}{V_*} = \frac{\nu}{\left(\frac{\tau_0}{\rho}\right)^{1/2}} = \frac{\nu}{\langle u \rangle} \left(\frac{1}{\frac{\tau_0}{\rho \langle u \rangle^2}}\right)^{1/2}$$
$$\approx \frac{\nu}{\langle u \rangle} \left(\frac{1}{\frac{\frac{1}{2} \cdot 0.0791}{\text{Re}^{1/4}}}\right) = \frac{\nu}{\langle u \rangle} 5 \cdot \text{Re}^{1/8}$$

for $2100 < \text{Re} < 10^5$, which provides a convenient way of estimating the thickness of the viscous sublayer (about 5 - 20 times this value).

()

()

()

Index Notation

(A)

What is index notation? It is simply a compact & convenient way of representing scalars, vectors, and tensors. It is particularly useful for fluid mechanics, especially (as we shall see) at low Re .

⇒ There is no new physics associated with index notation, however it can reveal symmetries & relations which were already there!

For any tensor, the order of the tensor is given by the

number of unrepeated ^(B) indices!

$a \Rightarrow$ no indices, scalar

$x_i, u_j \Rightarrow$ one index, both are vectors

$\sigma_{ij} \Rightarrow$ two indices, 2nd order tensor

$\epsilon_{ijk} \Rightarrow$ 3 indices, 3rd order tensor

The letters used as subscripts don't matter, e.g. x_i, x_j, x_p , etc. are equivalent

\Rightarrow exception: in an equation, each term must have the same unrepeated indices, e.g.

$$x_i = y_i \text{ is same as } \underset{\sim}{x} = \underset{\sim}{y}$$

but $x_i = y_j$ is an error!

A key feature of index notation [Ⓢ] is the dot product:

⇒ Repeated indices (in a product) implies summation!

$$\text{Thus: } \underset{\sim}{x}_i \underset{\sim}{y}_i \equiv \underset{\sim}{x} \cdot \underset{\sim}{y} = \sum_i x_i y_i$$

$$(\text{e.g., } x_i y_i = x_1 y_1 + x_2 y_2 + x_3 y_3)$$

Just think of how you would code it up on a computer using loops!

The vector composition or outer product is also simple:

$$\underset{\sim}{A} = \underset{\sim}{x} \underset{\sim}{y} \text{ is given by } A_{ij} = x_i y_j$$

Since there are two unrepeated indices, $x_i y_j$ is a 2nd order tensor!

* You cannot repeat an index ^(D) in any product more than once:

$$x_i y_j z_i \equiv y_j (x_i \cdot z_i) \text{ (ok)}$$

$$x_i y_i z_i \equiv \underline{\underline{\text{error}}}$$

The order of multiplication (dot product) is preserved by the names/order of the indices!

$$\text{Remember } A_{ij} x_j = b_i ?$$

In index notation:

$$A_{ij} x_j = b_i$$

To take the transpose, just reverse the order:

$$(A_{ij})^T = A_{ji}$$

Remember the Normal Equations? \textcircled{E}

$$\underset{\approx}{A}^T \underset{\approx}{A} \underset{\sim}{x} = \underset{\approx}{A}^T \underset{\sim}{b}$$

We would write this as

$$A_{ki} A_{kj} x_j = A_{ki} b_k$$

We could also look at the residual from linear regression:

$$r_i = A_{ij} x_j - b_i$$

$$\underset{\sim}{r} \cdot \underset{\sim}{r} = (A_{ij} x_j - b_i)(A_{ik} x_k - b_i)$$

Note that there are no unrepeated indices in the product, so it's a scalar, and that we switched a pair of "j"s to "k"s to avoid repeating j too many times! j was repeated

already, so this is OK, e.g. \textcircled{F}

while $x_j x_j = x_k x_k$ → both are scalars
 $x_j \neq x_k$ → unrepeated!

We define a couple of things:

$\nabla \equiv \frac{\partial}{\partial x_i}$ ← gradient operator
(or j , or k , etc.)

$\mathbb{I} \equiv \delta_{ij}$ ← Kronecker δ $\neq k$
(Identity matrix)

$$\delta_{ij} = \begin{cases} 0 & i \neq j \\ 1 & i = j \end{cases}$$

Note: $\frac{\partial x_i}{\partial x_j} = \delta_{ij}$ (Identity matrix)

$$\frac{\partial x_i}{\partial x_i} = \delta_{ii} = 1 + 1 + 1 = \underline{\underline{3}}$$

OK, let's use this to solve \textcircled{G}
for the Normal Equations!

Recall we had $\nabla_{\underline{w}} (\underline{w}^T \underline{w}) = 0$

In index notation:

$$\frac{\partial}{\partial x_i} \left\{ (A_{jk} x_k - b_j)(A_{j\ell} x_\ell - b_j) \right\}$$

$$= \frac{\partial}{\partial x_i} \left\{ A_{jk} x_k A_{j\ell} x_\ell - b_j A_{j\ell} x_\ell \right. \\ \left. - A_{jk} x_k b_j + b_j b_j \right\}$$

Or, since we only have to preserve
the order of the indices:

$$= \frac{\partial}{\partial x_i} \left\{ A_{jk} A_{j\ell} x_k x_\ell - 2 A_{jk} b_j x_k \right. \\ \left. + b_j b_j \right\}$$

Note that we combined the ^(H) two middle terms since

$$A_{jk} x_k \equiv A_{jl} x_l$$

The use of k or l was indeterminate because they were repeated. Only the unrepeated index " j " has to be the same on both sides!

OK, now we take some derivatives.
Note that A_{ij} and b_j are constants, so they pop out!

$$\nabla_{\vec{x}} (\vec{x}^T \vec{x}) \equiv A_{jk} A_{jl} \frac{\partial}{\partial x_i} (x_k x_l)$$

$$= 2 A_{jk} b_j \frac{\partial x_k}{\partial x_i} + \cancel{\frac{\partial b_j b_j}{\partial x_i}}$$

$$\downarrow$$
$$\delta_{ki}$$

(I)

Now we compute the first term:

$$\frac{\partial}{\partial x_i} (x_k x_l) = x_k \frac{\partial x_l}{\partial x_i} + x_l \frac{\partial x_k}{\partial x_i}$$

(chain rule)

$$= x_k \delta_{il} + x_l \delta_{ik}$$

$$\text{So: } \nabla_{\vec{x}} (\vec{v}^T \vec{v}) \equiv A_{jk} A_{jl} (x_k \delta_{il} + x_l \delta_{ik}) - 2 A_{jk} b_j \delta_{ik}$$

Taking the dot product of a matrix (or vector) with the identity matrix leaves it unchanged. In index notation this is:

$$A_{ij} \delta_{jk} = A_{ik}$$

(just replace the "j" with a "k")

(J)

So:

$$\nabla_{\underline{x}} (\underline{x}^T \underline{A} \underline{x}) \equiv A_{jk} A_{ji} x_k + A_{ji} A_{j\ell} x_\ell - 2 A_{ji} b_j$$

Now the first two terms are identical since in both cases "l" and "k" are repeated indices and thus indeterminate.

So:

$$\nabla_{\underline{x}} (\underline{x}^T \underline{A} \underline{x}) = 0 \text{ becomes:}$$

$$2 A_{ji} A_{jk} x_k - 2 A_{ji} b_j = 0$$

$$\text{or } A_{ji} A_{jk} x_k = A_{ji} b_j$$

Which is the same as:

$$\underline{A}^T \underline{A} \underline{x} = \underline{A}^T \underline{b} !$$

In addition to the S.F.ⁿ,
there is another special beast we'll use:

$\epsilon_{ijk} \equiv 3^{\text{rd}}$ order alternating \textcircled{K} tensor

We use this in computing the cross-product

$$\epsilon_{ijk} = \begin{cases} 0 & i=j, j=k, \text{ or } i=k \\ 1 & i, j, k \text{ cyclic} \\ -1 & i, j, k \text{ counter-cyclic} \end{cases}$$

Thus:

$$\epsilon_{123} = \epsilon_{312} = \epsilon_{231} = 1$$

$$\epsilon_{321} = \epsilon_{132} = \epsilon_{213} = -1$$

These are the only non-zero elements!

The cross-product is:

$$\underline{\tilde{A}} \times \underline{\tilde{B}} = \underline{\tilde{C}} \text{ is}$$

$$C_i = \epsilon_{ijk} A_j B_k$$

Note that just as

$$\underline{\underline{A}} \times \underline{\underline{B}} = - \underline{\underline{B}} \times \underline{\underline{A}}$$

In index notation we have

$$\epsilon_{ijk} = - \epsilon_{jik}$$

switching order throws in a (-)!

If ϵ_{ijk} is cyclic, ϵ_{jik} must be counter-cyclic & vice versa.

Technically, any matrix for which $A_{ij} = A_{ji}$ is termed symmetric

A matrix for which $B_{ij} = -B_{ji}$ is anti-symmetric

Note: The double dot product (e.g. $A_{ij} B_{ij}$ - no unrepeated indices) of a symmetric & an anti-symmetric

matrix is zero

(M)

$$A_{ij} B_{ij} = A_{ji} B_{ji} \quad \text{if } A^T = A$$

$$= -A_{ji} B_{ji} \quad \text{if } B^T = -B$$

$$\equiv -A_{ij} B_{ij} \quad (\text{relabeling repeated indices})$$

Thus since $A_{ij} B_{ij} = -A_{ij} B_{ij}$,
both are zero!

We can use this to prove that

$$\nabla \times (\nabla \phi) = 0:$$

$$\epsilon_{ijk} \frac{\partial}{\partial x_j} \left(\frac{\partial \phi}{\partial x_k} \right) = \underbrace{\epsilon_{ijk}}_{\text{anti-symmetric}} \underbrace{\frac{\partial^2}{\partial x_j \partial x_k}}_{\text{symmetric}} (\phi)$$

$$\therefore = 0!$$

Another useful concept is isotropy ^(N)

Mathematically, a tensor is isotropic if it is invariant under rotation of the coordinate system

Physically, it's isotropic if it looks the same from all directions!

A sphere is isotropic, a football isn't!

All scalars are isotropic

No vectors are isotropic!

The most general 2nd order

isotropic tensor is $\lambda \delta_{ij}$

\hookrightarrow const. scalar

The most general 3rd order tensor

is $\lambda \epsilon_{ijk}$

The most general 4th order [⊙] isotropic tensor is:

$$A_{ijkl} = \lambda_1 \delta_{ij} \delta_{kl} + \lambda_2 \delta_{ik} \delta_{jl} + \lambda_3 \delta_{il} \delta_{jk}$$

where $\lambda_1, \lambda_2, \lambda_3$ are scalars

We can use this to prove vector calculus identities

From texts, we have

$$\nabla \times (\nabla \times \underline{u}) = \nabla (\nabla \cdot \underline{u}) - \nabla^2 \underline{u}$$

Let's prove this!

$$\nabla \times (\nabla \times \underline{u}) \equiv \epsilon_{ijk} \frac{\partial}{\partial x_j} \left(\epsilon_{klm} \frac{\partial u_m}{\partial x_l} \right)$$

Note the order of the indices.

This is important when working with ϵ_{ijk} !

Thus:

$$\nabla \times (\nabla \times \underline{u}) \equiv \epsilon_{ijk} \epsilon_{klm} \frac{\partial^2 u_m}{\partial x_j \partial x_l} \quad \textcircled{P}$$

What's $\epsilon_{ijk} \epsilon_{klm}$??

4 unrepeated indices, so it's a 4th order tensor.

ϵ_{ijk} is isotropic, so the product is also isotropic

Hence:

$$\epsilon_{ijk} \epsilon_{klm} = \lambda_1 \delta_{ij} \delta_{lm} + \lambda_2 \delta_{il} \delta_{jm} + \lambda_3 \delta_{im} \delta_{jl}$$

where λ_1, λ_2 & λ_3 are to be determined.

We can calculate these by multiplying both sides by each of the three terms on the RHS (one at a time!) which then yields three eq^{ns} for the three λ 's.

Q

So:

$$\epsilon_{ijk} \epsilon_{klm} \delta_{ij} \delta_{lm} \equiv \epsilon_{iik} \epsilon_{kll}$$

This is zero because ϵ_{iik} is zero for all i, k . Also,

$\epsilon_{ijk} \delta_{ij} \equiv 0$ because ϵ_{ijk} is anti-symmetric and δ_{ij} is symmetric, so the double-dot product of the two is like wise zero!

Now for the RHS:

$$(\lambda_1 \delta_{ij} \delta_{lm} + \lambda_2 \delta_{il} \delta_{jm} + \lambda_3 \delta_{im} \delta_{jl}) \times (\delta_{ij} \delta_{lm}) = \lambda_1 \delta_{ii} \delta_{ll} + \lambda_2 \delta_{im} \delta_{im}$$

$$+ \lambda_3 \delta_{im} \delta_{im}$$

$$= \lambda_1 (3)(3) + \lambda_2 (3) + \lambda_3 (3)$$

$$\text{since } \delta_{ii} = 1 + 1 + 1 = 3!$$

We thus get the first equation: \textcircled{R}

$$0 = 9\lambda_1 + 3\lambda_2 + 3\lambda_3$$

Now for the second term. We multiply both sides by $\delta_{ix}\delta_{jm}$.

We get:

$$\epsilon_{ijk} \epsilon_{klm} \delta_{ix} \delta_{jm} = 3\lambda_1 + 9\lambda_2 + 3\lambda_3$$

Where the RHS was calculated the same way as before.

The LHS is:

$$\epsilon_{ijk} \epsilon_{kij}$$

Now if ϵ_{ijk} is cyclic, so is ϵ_{kij} . Likewise, if ϵ_{ijk} is counter-cyclic, so is ϵ_{kij} . Thus, the product is just $(1)(1) = 1$ or $(-1)(-1) = 1$ for all six non-zero elements!

This yields:

(5)

$$6 = 3\lambda_1 + 9\lambda_2 + 3\lambda_3$$

Like wise, the multiplication by the last term yields:

$$\begin{aligned}\epsilon_{ijk} \epsilon_{klm} \delta_{im} \delta_{jl} &= 3\lambda_1 + 3\lambda_2 + 9\lambda_3 \\ &= \epsilon_{ijk} \epsilon_{kji} = -6\end{aligned}$$

These equations have the solution:

$$\lambda_1 = 0, \lambda_2 = 1, \lambda_3 = -1$$

Thus:

$$\epsilon_{ijk} \epsilon_{klm} = \delta_{il} \delta_{jm} - \delta_{im} \delta_{jl}$$

and hence:

$$\begin{aligned}\nabla_{\sim} \times (\nabla_{\sim} \times u) &\equiv \epsilon_{ijk} \epsilon_{klm} \frac{\partial^2 u_m}{\partial x_j \partial x_l} \\ &= (\delta_{il} \delta_{jm} - \delta_{im} \delta_{jl}) \frac{\partial^2 u_m}{\partial x_j \partial x_l}\end{aligned}$$

$$\begin{aligned}
&= \delta_{il} \delta_{jm} \frac{\partial^2 u_m}{\partial x_j \partial x_l} - \delta_{im} \delta_{jl} \frac{\partial^2 u_m}{\partial x_j \partial x_l} \\
&= \frac{\partial}{\partial x_i} \left(\frac{\partial u_j}{\partial x_j} \right) - \frac{\partial^2 u_i}{\partial x_j^2} \\
&\equiv \nabla \cdot (\nabla \cdot \underline{u}) - \nabla^2 \underline{u}
\end{aligned}$$

which completes the identity!

The last concept we wish to explore is the difference between pseudo-tensors and physical tensors.

This distinction arises from the choice of right handed or left-handed coordinate systems. A pseudo tensor is one whose sign depends on this choice, a physical tensor is one which doesn't!

Let's look at some examples: \textcircled{U}

physical

velocity

force

stress

δ_{ij}

pseudo

angular velocity

torque

vorticity

ϵ_{ijk}

We go from one to the other
via the cross-product!

The vorticity is defined as:

$$\omega_i \equiv \epsilon_{ijk} \frac{\partial u_k}{\partial x_j} \quad (\text{e.g. } \underline{\omega} = \underline{\nabla} \times \underline{u})$$

ω_i is a pseudovector

u_k is a physical vector

Like wise,

$$\underline{\nabla} \times \underline{\omega} \equiv \epsilon_{ijk} \frac{\partial \omega_k}{\partial x_j} \text{ is a } \underline{\text{physical}}$$

vector, In fact, our vector

(V)

identity yields

$$\begin{aligned}\nabla \times \underline{\omega} &\equiv \varepsilon_{ijk} \frac{\partial \omega_k}{\partial x_j} = \varepsilon_{ijk} \frac{\partial}{\partial x_j} \left(\varepsilon_{klm} \frac{\partial u_m}{\partial x_l} \right) \\ &= \varepsilon_{ijk} \varepsilon_{klm} \frac{\partial^2 u_m}{\partial x_j \partial x_l} \\ &= \frac{\partial}{\partial x_i} \left(\frac{\partial u_j}{\partial x_j} \right) - \frac{\partial^2 u_i}{\partial x_j^2}\end{aligned}$$

which is a physical vector

The reason why we make this distinction is that a physical tensor and a pseudotensor can never be equal!

How can we use this? Consider the following problem. Suppose we have a body of revolution whose orientation is specified by the unit vector ρ_i , e.g.

(W)



It's settling under gravity with a net force \vec{F} (physical vector).

At very low Re , how does its angular velocity (pseudovector) $\vec{\Omega}$ depend on \vec{p} ??

At low Re , we can show that $\vec{\Omega}$ is proportional to \vec{F}

Thus $\Omega_i = A_{ik} F_k$ where A_{ik} must be a pseudotensor which depends only on \vec{p} and the object's shape!

There is only one way to \otimes
do this!!

$$A_{ik} = \lambda \epsilon_{ijk} P_j$$

where λ is some scalar!

$$\text{Thus } \Omega_i = \lambda \epsilon_{ijk} P_j F_k$$

and a single experiment can
determine λ , which is constant
for all orientations!

Likewise, if the object has
fore-and-aft symmetry (e.g.,
a football, which looks the same
for \underline{P} and $-\underline{P}$ orientations) we
have that A_{ik} must be an even
function of \underline{P} . Since the only
possible form of A_{ik} is

odd in \tilde{p} , λ must be zero for such objects!

Thus, in example, rods (fore-aft symmetric cylinders) don't rotate when settling at low Re , regardless of orientation!

We can also look at the settling velocity U_i (physical vector) for some \tilde{F} :

$$U_i = B_{ij} F_j$$

here B_{ij} is a physical tensor which depends on \tilde{p} . The most general form is:

$$B_{ij} = \lambda_1 \delta_{ij} + \lambda_2 P_i P_j$$

(2)

Thus:

$$U_i = (\lambda_1 \delta_{ij} + \lambda_2 P_i P_j) F_j$$

where λ_1 & λ_2 must be determined from experiment or (nasty) calculation. Actually, by measuring the settling velocity of a rod broadside on and end on, you can get λ_1 & λ_2 , allowing you to calculate \underline{U} for all orientations - including the lateral velocity for inclined rods! We'll do this experiment later this semester.