

Liviu I. Nicolaescu

# An Invitation to Morse Theory

– Monograph –

September 13, 2018

Springer

Berlin Heidelberg New York

Hong Kong London

Milan Paris Tokyo



To my mother, with deepest gratitude

As the the title suggests, the goal of this book is to give the reader a taste of the “unreasonable effectiveness” of Morse theory. The main idea behind this technique can be easily visualized.

Suppose  $M$  is a smooth, compact manifold, which for simplicity we assume is embedded in a Euclidean space  $E$ . We would like to understand basic topological invariants of  $M$  such as its homology, and we attempt a “slicing” technique.

We fix a unit vector  $\mathbf{u}$  in  $E$  and we start slicing  $M$  with the family of hyperplanes perpendicular to  $\mathbf{u}$ . Such a hyperplane will in general intersect  $M$  along a submanifold (slice). The manifold can be recovered by continuously stacking the slices on top of each other in the same order as they were cut out of  $M$ .

Think of the collection of slices as a deck of cards of various shapes. If we let these slices continuously pile up in the order they were produced, we notice an increasing stack of slices. As this stack grows, we observe that there are moments of time when its shape suffers a qualitative change. Morse theory is about extracting quantifiable information by studying the evolution of the shape of this growing stack of slices.

From a mathematical point of view we have a smooth function

$$h : M \rightarrow \mathbb{R}, \quad h(x) = \langle \mathbf{u}, x \rangle.$$

The above slices are the level sets of  $h$ ,

$$\{x \in M; h(x) = \text{const}\},$$

and the growing stack is the time dependent sublevel set

$$\{x \in M; h(x) \leq t\}, \quad t \in \mathbb{R}.$$

The moments of time when the pile changes its shape are called the *critical values* of  $h$  and correspond to moments of time  $t$  when the corresponding hyperplane  $\{\langle \mathbf{u}, x \rangle = t\}$  intersects  $M$  tangentially. Morse theory explains how to describe the shape change in terms of *local* invariants of  $h$ .

A related slicing technique was employed in the study of the topology of algebraic manifolds called the *Picard–Lefschetz theory*. This theory is back in fashion due mainly to Donaldson’s pioneering work on symplectic Lefschetz pencils.

The present book is divided into three conceptually distinct parts. In the first part we lay the foundations of Morse theory (over the reals). The second part consists of applications of Morse theory over the reals, while the last part describes the basics and some applications of complex Morse theory, a.k.a. Picard–Lefschetz theory. Here is a more detailed presentation of the contents.

In chapter 1 we introduce the basic notions of the theory and we describe the main properties of Morse functions: their rigid local structure (Morse

lemma) and their abundance (Morse functions are generic). To aid the reader we have sprinkled the presentation with many examples and figures. One recurring simple example that we use as a testing ground is that of a natural Morse function arising in the design of robot arms. We conclude this chapter with a simple but famous application of Morse theory. We show that the expected number of critical points of the restriction of a random linear map  $\ell : \mathbb{R}^3 \rightarrow \mathbb{R}$  to a knot  $K \hookrightarrow \mathbb{R}^3$  is described by the total curvature of the knot. As a consequence, we obtain Milnor’s celebrated result [M0] stating that if a closed curve in  $\mathbb{R}^3$  is “not too curved”, then it is not knotted.

Chapter 2 is the technical core of the book. Here we prove the fundamental facts of Morse theory: crossing a critical level corresponds to attaching a handle and Morse inequalities. Inescapably, our approach was greatly influenced by the classical sources on this subject, more precisely Milnor’s beautiful books on Morse theory and  $h$ -cobordism [M3, M4].

The operation of handle addition is much more subtle than it first appears, and since it is *the* fundamental device for manifold (re)construction, we devoted an entire section to this operation and its relationship to cobordism and surgery. In particular, we discuss in some detail the topological effects of the operation of surgery on knots in  $S^3$  and illustrate this in the case of the trefoil knot.

In chapter 2 we also discuss in some detail dynamical aspects of Morse theory. More precisely, we present the techniques of S. Smale about modifying a Morse function so that it is self-indexing and its stable/unstable manifolds intersect transversally. This allows us to give a very simple description of an isomorphism between the singular homology of a compact smooth manifold and the (finite dimensional) Morse–Floer homology determined by a Morse function, that is, the homology of a complex whose chains are formal linear combinations of critical points and whose boundary is described by the connecting trajectories of the gradient flow. We have also included a brief section on Morse–Bott theory, since it comes in handy in many concrete situations.

We conclude this chapter with a section of a slightly different flavor. Whereas Morse theory tries to extract topological information from information about critical points of a function, min-max theory tries to achieve the opposite goal, namely to transform topological knowledge into information about the critical points of a function. In particular, we discuss the Lusternik–Schnirelmann category of a space, which is a homotopy invariant particularly adept at detecting critical points.

Chapter 3 is devoted entirely to applications of Morse theory. We present relatively few examples, but we use them as pretexts for wandering in many parts of mathematics that are still active areas of research. We start by presenting a recent result of M. Farber and D. Schütz, [FaSch], on the Betti numbers of the space of planar polygons, or equivalently, the space of configurations of planar robot arms such that the end-point of the arm coincides with the initial joint. Besides its intrinsic interest, this application has an added academic bonus: it gives the reader the chance to witness Morse theory in

action, in all its splendor. Additionally it exposes the reader to the concept of Bott-Samelson cycle which is useful in many other applications of Morse theory.

We next discuss two classical applications: the computation of the Poincaré polynomials of complex Grassmannians, and an old result of S. Lefschetz concerning the topology of Stein manifolds.

The complex Grassmannians give us a pretext to discuss at length the Morse theory of moment maps of Hamiltonian torus actions. We prove that these moment maps are Morse–Bott functions. We then proceed to give a complete presentation of the equivariant localization theorem of Atiyah, Borel, and Bott (for  $S^1$ -actions only), and we use this theorem to prove a result of P. Conner [Co]: the sum of the Betti numbers of a compact, oriented smooth manifold is greater than the sum of the Betti numbers of the fixed point set of any smooth  $S^1$ -action. Conner’s theorem implies among other things that the moment maps of Hamiltonian torus actions are *perfect* Morse–Bott function. The (complex) Grassmannians are coadjoint orbits of unitary groups, and as such they are equipped with many Hamiltonian torus actions leading to many choices of perfect Morse functions on Grassmannians. We conclude with a section on the celebrated Duistermaat-Heckman formula.

Chapter 4 is more theoretical in nature but it opens the door to an active area of research, namely Floer homology. While still in the finite dimensional context, we take a closer look at the topological structure of a Morse-Smale flow. The main results are inspired by our recent investigations [Ni2] and, to the best of our knowledge, they seem to have never appeared in the Morse theoretic literature.

The key results of this chapter (Theorem 4.32 and Theorem 4.33) state that a Morse flow on a compact manifold satisfies the Smale transversality condition if and only if the stratification given by the unstable manifolds satisfies the Whitney regularity conditions. Because the theory of Whitney stratifications is not part a standard graduate curriculum we devoted a large part of this chapter surveying this theory. Since the proofs of the main results in this area are notoriously complex, we decided to skip most of them opting instead for copious references and numerous illuminating examples.

These results provide a rigorous foundation to R. Thom’s original insight [Th]. One immediate consequence of Theorem 4.33 is a result of F. Laudenbach [Lau] on the nature of the singularities of the closure of an unstable manifold of a Morse-Smale flow.

In Section 4.4 we investigate the spaces of tunnelings between two critical points of a Morse-Smale flow. Using a recent idea of P. Kronheimer and T. Mrowka [KrMr] we show that these spaces admit natural compactifications as manifolds with corners. We do not use this fact anywhere else in the book, but since it is part of the core of Morse theoretic facts available to the modern geometer we thought we had to include a short proof.

In the last section of this chapter we have a second look at the Morse-Floer complex, from a purely dynamic point of view. We define the boundary

operator  $\partial$  in terms of signed counts of tunnelings, and we give a purely dynamic proof of the equality  $\partial^2 = 0$ . Our proof is similar in spirit to the proof in [Lau], but we have deliberately avoided the usage of currents because the unstable manifolds may not have finite volume. Instead, we use the theory of Whitney stratifications to show that the equality  $\partial^2 = 0$  is a consequence of the cobordism invariance of the degree of a map.

The application to the topology of Stein manifolds offered us a pretext for the last chapter of the book on the Picard–Lefschetz theory. Given a complex submanifold  $M$  of a complex projective space, we start slicing it using a (complex) 1-dimensional family of projective hyperplanes. Most slices are smooth hypersurfaces of  $M$ , but a few of them have mild singularities (nodes). Such a slicing can be encoded by a holomorphic Morse map  $M \rightarrow \mathbb{C}\mathbb{P}^1$ .

There is one significant difference between the real and the complex situations. In the real case, the set of regular values is *disconnected*, while in the complex case this set is *connected* since it is a punctured sphere. In the complex case we study not what happens as we cross a critical value, but what happens when we go once around it. This is the content of the Picard–Lefschetz theorem.

We give complete proofs of the local and global Picard–Lefschetz formulæ and we describe basic applications of these results to the topology of algebraic manifolds.

We conclude the book with a chapter containing a few exercises and solutions to (some of) them. Many of them are quite challenging and contain additional interesting information we did not include in the main body, since it may have been distracting. However, we strongly recommend to the reader to try solving as many of them as possible, since this is the most efficient way of grasping the subtleties of the concepts discussed in the book. The solutions of these more challenging problems are contained in the last section of the book.

Penetrating the inherently eclectic subject of Morse theory requires quite a varied background. The present book is addressed to a reader familiar with the basics of algebraic topology (fundamental group, singular (co)homology, Poincaré duality, e.g., Chapters 0–3 of [Ha]) and the basics of differential geometry (vector fields and their flows, Lie and exterior derivative, integration on manifolds, basics of Lie groups and Riemannian geometry, e.g., Chapters 1–4 in [Nil]). In a very limited number of places we had to use less familiar technical facts, but we believe that the logic of the main arguments is not obscured by their presence.

**Acknowledgments.** This book grew out of notes I wrote for a one-semester graduate course in topology at the University of Notre Dame in the fall of 2005. I want to thank the attending students, Eduard Balreira, Daniel Cibotaru, Stacy Hoehn, Sasha Lyapina, for their comments questions and suggestions, which played an important role in smoothing out many rough patches

in presentation. While working on these notes I had many enlightening conversations on Morse theory with my colleague Richard Hind. I want to thank him for calmly tolerating my frequent incursions into his office, and especially for the several of his comments and examples I have incorporated in the book.

Last, but not the least, I want thank my wife. Her support allowed me to ignore the “publish or perish” pressure of these fast times, and I could ruminate on the ideas in this book with joyous abandonment.

#### **What’s new in the second edition**

- I have included several immediate but useful consequences of the results proved in the first edition: Corollary 1.26 and Theorem 2.37.
- I have included several several new sections of applications: Section 1.3, Section 3.1 and Section 3.7.
- The whole of Chapter 4 is new.
- I have added several new exercises.
- I have fixed many typos and errors in the first edition. In this process I was aided by many readers. I would especially like to thank Professor *Steve Ferry* of Rutgers University for his many suggestions, corrections and overall very useful critique. I would also like to thank Leonardo Biliotti and Alessandro Ghigi for drawing my attention to some problems in Theorems 3.45 and 3.48 of the first edition (Theorems 3.63 and 3.64 in the current edition.) I have addressed them in the current edition.

This work was partially supported by NSF grants DMS-0303601 and DMS-1005745.



---

## Notations and Conventions

- For every set  $A$  we denote by  $\#A$  its cardinality.
- For  $\mathbb{K} = \mathbb{R}, \mathbb{C}$ ,  $r > 0$  and  $M$  a smooth manifold we denote by  $\underline{\mathbb{K}}_M^r$  the trivial vector bundle  $\mathbb{K}^r \times M \rightarrow M$ .
- $\mathbf{i} := \sqrt{-1}$ . **Re** denotes the real part, and **Im** denotes the imaginary part.
- For every finite dimensional vector space  $\mathbf{E}$  we denote by  $\text{End}(\mathbf{E})$  the space of linear operators  $\mathbf{E} \rightarrow \mathbf{E}$ .
- An *Euclidean space* is a finite dimensional real vector space  $\mathbf{E}$  equipped with a symmetric positive definite inner product  $(\bullet, \bullet) : \mathbf{E} \times \mathbf{E} \rightarrow \mathbb{R}$ .
- For every smooth manifold  $M$  we denote by  $TM$  the tangent bundle, by  $T_x M$  the tangent space to  $M$  at  $x \in M$  and by  $T_x^* M$  the cotangent space at  $x$ .
- For every smooth manifold and any smooth submanifold  $S \hookrightarrow M$  we denote by  $T_S M$  the *normal bundle* of  $S$  in  $M$  defined as the quotient  $T_S M := (TM)|_S / TS$ . The *conormal bundle* of  $S$  in  $M$  is the bundle  $T_S^* M \rightarrow S$  defined as the kernel of the restriction map  $(T^* M)|_S \rightarrow T^* S$ .
- $\text{Vect}(M)$  denotes the space of smooth vector fields on  $M$ .
- $\Omega^p(M)$  denotes the space of smooth  $p$ -forms on  $M$ , while  $\Omega_{cpt}^p(M)$  the space of compactly supported smooth  $p$ -forms.
- If  $F : M \rightarrow N$  is a smooth map between smooth manifolds we will denote its differential by  $DF$  or  $F_*$ .  $DF_x$  will denote the differential of  $F$  at  $x \in M$  which is a linear map  $DF_x : T_x M \rightarrow T_x N$ .  $F^* : \Omega^p(N) \rightarrow \Omega^p(M)$  is the pullback by  $F$ .
- $\pitchfork :=$  transverse intersection.
- $\sqcup :=$  disjoint union.
- For every  $X, Y \in \text{Vect}(M)$  we denote by  $L_X$  the Lie derivative along  $X$  and by  $[X, Y]$  the Lie bracket  $[X, Y] = L_X Y$ . The operation contraction by  $X$  is denoted by  $i_X$  or  $X \lrcorner$ .
- We will orient the manifolds with boundary using the *outer-normal -first* convention.
- The total space of a fiber bundle will be oriented using the *fiber-first convention*.

XII

- $\mathfrak{so}(n)$  denotes the Lie algebra of  $SO(n)$ ,  $\mathfrak{u}(n)$  denotes the Lie algebra of  $U(n)$  etc.
- $\text{Diag}(c_1, \dots, c_n)$  denotes the diagonal  $n \times n$  matrix with entries  $c_1, \dots, c_n$ .

---

# Contents

<b>Notations and conventions</b> .....	XII
<b>1 Morse Functions</b> .....	1
1.1 The Local Structure of Morse Functions .....	1
1.2 Existence of Morse Functions .....	16
1.3 Morse Functions on Knots .....	23
<b>2 The Topology of Morse Functions</b> .....	31
2.1 Surgery, Handle Attachment, and Cobordisms .....	31
2.2 The Topology of Sublevel Sets .....	42
2.3 Morse Inequalities .....	54
2.4 Morse–Smale Dynamics .....	62
2.5 Morse–Floer Homology .....	73
2.6 Morse–Bott Functions .....	79
2.7 Min–Max Theory .....	83
<b>3 Applications</b> .....	95
3.1 The Moduli Space of Planar Polygons .....	95
3.2 The Cohomology of Complex Grassmannians .....	107
3.3 The Lefschetz Hyperplane Theorem .....	113
3.4 Symplectic Manifolds and Hamiltonian Flows .....	120
3.5 Morse Theory of Moment Maps .....	140
3.6 $S^1$ -Equivariant Localization .....	160
3.7 The Duistermaat–Heckman formula .....	175
<b>4 Morse–Smale Flows and Whitney Stratifications</b> .....	189
4.1 The Gap Between Two Vector Subspaces .....	190
4.2 The Whitney Regularity Conditions .....	197
4.3 Smale transversality $\iff$ Whitney regularity .....	210
4.4 Spaces of tunnelings of Morse–Smale flows .....	221
4.5 The Morse–Floer complex revisited .....	234

<b>5</b>	<b>Basics of Complex Morse Theory</b> .....	243
5.1	Some Fundamental Constructions .....	244
5.2	Topological Applications of Lefschetz Pencils .....	248
5.3	The Hard Lefschetz Theorem .....	259
5.4	Vanishing Cycles and Local Monodromy .....	264
5.5	Proof of the Picard–Lefschetz formula .....	274
5.6	Global Picard–Lefschetz Formulæ .....	279
<b>6</b>	<b>Exercises and Solutions</b> .....	285
6.1	Exercises .....	285
6.2	Solutions to Selected Exercises .....	303
	<b>References</b> .....	331
	<b>Index</b> .....	335

---

## Morse Functions

In this first chapter we introduce the reader to the main characters of our story, namely the Morse functions, and we describe the properties which make them so useful. We describe their very special local structure (Morse lemma) and then we show that there are plenty of them around.

### 1.1 The Local Structure of Morse Functions

Suppose that  $F : M \rightarrow N$  is a smooth (i.e.,  $C^\infty$ ) map between smooth manifolds. The differential of  $F$  defines for every  $x \in M$  a linear map

$$DF_x : T_x M \rightarrow T_{F(x)} N.$$

**Definition 1.1.** (a) *The point  $x \in M$  is called a critical point of  $F$  if*

$$\text{rank } DF_x < \min(\dim M, \dim N).$$

*A point  $x \in M$  is called a regular point of  $F$  if it is not a critical point. The collection of all the critical points of  $F$  is called the critical set of  $F$  and is denoted by  $\mathbf{Cr}_F$ .*

(b) *The point  $y \in N$  is called a critical value of  $F$  if the fiber  $F^{-1}(y)$  contains a critical point of  $F$ . A point  $y \in N$  is called a regular value of  $F$  if it is not a critical value. The collection of all critical values of  $F$  is called the discriminant set of  $F$  and is denoted by  $\Delta_F$ .*

(c) *A subset  $S \subset N$  is said to be negligible if for every smooth open embedding  $\Phi : \mathbb{R}^n \rightarrow N$ ,  $n = \dim N$ , the preimage  $\Phi^{-1}(S)$  has Lebesgue measure zero in  $\mathbb{R}^n$ .  $\square$*

**Theorem 1.2 (Morse–Sard–Federer).** *Suppose that  $M$  and  $N$  are smooth manifolds and  $F : M \rightarrow N$  is a smooth map. Then the Hausdorff dimension of*

the discriminant set  $\Delta_F$  is at most  $\dim N - 1$ . In particular, the discriminant set is negligible in  $N$ . Moreover, if  $F(M)$  has nonempty interior, then the set of regular values is dense in  $F(M)$ .  $\square$

For a proof we refer to Federer [Fed, Theorem 3.4.3] or Milnor [M2].

*Remark 1.3.* (a) If  $M$  and  $N$  are real analytic manifolds and  $F$  is a proper real analytic map then we can be more precise. The discriminant set is a locally finite union of real analytic submanifolds of  $N$  of dimensions less than  $\dim N$ . Exercise 6.1 may perhaps explain why the set of critical values is called discriminant.

(b) The range of a smooth map  $F : M \rightarrow N$  may have empty interior. For example, the range of the map  $F : \mathbb{R}^3 \rightarrow \mathbb{R}^2$ ,  $F(x, y, z) = (x, 0)$ , is the  $x$ -axis of the Cartesian plane  $\mathbb{R}^2$ . The discriminant set of this map coincides with the range.  $\square$

**Example 1.4.** Suppose  $f : M \rightarrow \mathbb{R}$  is a smooth function. Then  $x_0 \in M$  is a critical point of  $f$  if and only if  $df|_{x_0} = 0 \in T_{x_0}^*M$ .

Suppose  $M$  is embedded in an Euclidean space  $E$  and  $f : E \rightarrow \mathbb{R}$  is a smooth function. Denote by  $f_M$  the restriction of  $f$  to  $M$ . A point  $x_0 \in M$  is a critical point of  $f_M$  if

$$\langle df, v \rangle = 0, \quad \forall v \in T_{x_0}M.$$

This happens if either  $x_0$  is a critical point of  $f$ , or  $df_{x_0} \neq 0$  and the tangent space to  $M$  at  $x_0$  is contained in the tangent space at  $x_0$  of the level set  $\{f = f(x_0)\}$ . If  $f$  happens to be a nonzero linear function, then all its level sets are hyperplanes perpendicular to a fixed vector  $\mathbf{u}$ , and  $x_0 \in M$  is a critical point of  $f_M$  if and only if  $\mathbf{u} \perp T_{x_0}M$ , i.e., the hyperplane determined by  $f$  and passing through  $x_0$  is tangent to  $M$ .

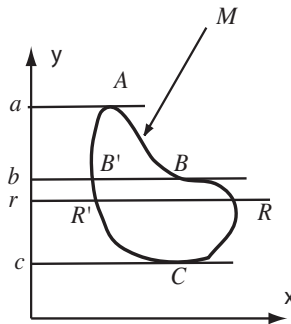

**Fig. 1.1.** The height function on a smooth curve in the plane.

In Figure 1.1 we have depicted a smooth curve  $M \subset \mathbb{R}^2$ . The points  $A, B, C$  are critical points of the linear function  $f(x, y) = y$ . The level sets of

this function are horizontal lines and the critical points of its restriction to  $M$  are the points where the tangent space to the curve is horizontal. The points  $a, b, c$  on the vertical axis are critical values, while  $r$  is a regular value.  $\square$

**Example 1.5 (Robot arms: critical configurations).** We begin in this example the study of the critical points of a smooth function which arises in the design of robot arms. We will discuss only a special case of the problem when the motion of the arm is constrained to a plane. For slightly different presentations we refer to the papers [Hau, KM, SV], which served as our sources of inspiration. The paper [Hau] discusses the most general version of this problem, when the motion of the arm is not necessarily constrained to a plane.

Fix positive real numbers  $r_1, \dots, r_n > 0$ ,  $n \geq 2$ . A (planar) *robot arm* (or *linkage*) with  $n$  segments is a continuous curve in the Euclidean plane consisting of  $n$  line segments

$$s_1 = [J_0J_1], \quad s_2 = [J_1J_2], \dots, \quad s_n = [J_{n-1}J_n]$$

of lengths

$$\text{dist}(J_i, J_{i-1}) = r_i, \quad i = 1, 2, \dots, n.$$

We will refer to the vertices  $J_i$  as the *joints* of the robot arm. We assume that  $J_0$  is fixed at the origin of the plane, and all the segments of the arm are allowed to rotate about the joints. Additionally, we require that the last joint be constrained to slide along the positive real semiaxis (see Figure 1.2).

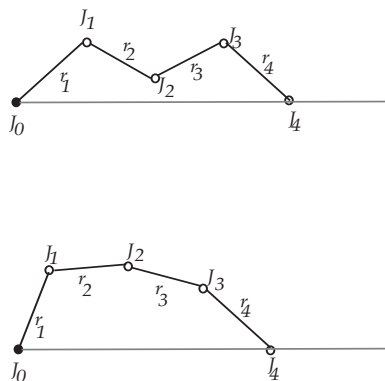

**Fig. 1.2.** A robot arm with four segments.

A (robot arm) *configuration* is a possible position of the robot arm subject to the above constraints. Mathematically a configuration is described by an  $n$ -uple

$$\mathbf{z} = (z_1, \dots, z_n) \in \mathbb{C}^n$$

constrained by

$$|z_k| = 1, \quad k = 1, 2, \dots, n, \quad \mathbf{Im} \sum_{k=1}^n r_k z_k = 0, \quad \mathbf{Re} \sum_{k=1}^n r_k z_k > 0.$$

Visually, if  $z_k = e^{i\theta_k}$ , then  $\theta_k$  measures the inclination of the  $k$ th segment of the arm. The position of  $k$ th joint  $J_k$  is described by the complex number  $r_1 z_1 + \dots + r_k z_k$ .

In Exercise 6.2 we ask the reader to verify that the space of configurations is a *smooth* hypersurface  $C$  of the  $n$ -dimensional manifold

$$M := \left\{ (\theta_1, \dots, \theta_n) \in (S^1)^n; \sum_{k=1}^n r_k \cos \theta_k > 0 \right\} \subset (S^1)^n,$$

described as the zero set of

$$\beta : M \rightarrow \mathbb{R}, \quad \beta(\theta_1, \dots, \theta_n) = \sum_{k=1}^n r_k \sin \theta_k = \mathbf{Im} \sum_{k=1}^n r_k z_k.$$

Consider the function  $h : (S^1)^n \rightarrow \mathbb{R}$  defined by

$$h(\theta_1, \dots, \theta_n) = \sum_{k=1}^n r_k \cos \theta_k = \mathbf{Re} \sum_{k=1}^n r_k z_k.$$

Observe that for every configuration  $\theta$  the number  $h(\theta)$  is the distance of the last joint from the origin. We would like to find the critical points of  $h|_C$ .

It is instructive to first visualize the level sets of  $h$  when  $n = 2$  and  $r_1 \neq r_2$ , as it captures the general paradigm. For every configuration  $\theta = (\theta_1, \theta_2)$  we have

$$|r_1 - r_2| \leq h(\theta) \leq r_1 + r_2.$$

For every  $c \in (|r_1 - r_2|, r_1 + r_2)$ , the level set  $\{h = c\}$  consists of two configurations symmetric with respect to the  $x$ -axis. When  $c = |r_1 \pm r_2|$  the level set consists of a single (critical) configuration. We deduce that the configuration space is a circle.

In general, a configuration  $\theta = (\theta_1, \dots, \theta_n) \in C$  is a critical point of the restriction of  $h$  to  $C$  if the differential of  $h$  at  $\theta$  is parallel to the differential at  $\theta$  of the constraint function  $\beta$  (which is the "normal" to this hypersurface). In other words,  $\theta$  is a critical point if and only if there exists a real scalar  $\lambda$  (Lagrange multiplier) such that

$$dh(\theta) = \lambda d\beta(\theta) \iff -r_k \sin \theta_k = \lambda r_k \cos \theta_k, \quad \forall k = 1, 2, \dots, n.$$

We discuss separately two cases.

**A.**  $\lambda = 0$ . In this case  $\sin \theta_k = 0, \forall k$ , that is,  $\theta_k \in \{0, \pi\}$ . If  $z_k = e^{i\theta_k}$  we obtain the critical points



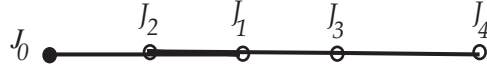

**Fig. 1.3.** A critical robot arm configuration.

$$(z_1, \dots, z_n) = (\epsilon_1, \dots, \epsilon_n), \quad \epsilon_k = \pm 1, \quad \sum_{k=1}^n r_k \epsilon_k = \mathbf{Re} \sum_k r_k z_k > 0.$$

**B.**  $\lambda \neq 0$ . We want to prove that this situation is impossible. We have

$$h(\boldsymbol{\theta}) = \sum_k r_k \cos \theta_k > 0$$

and thus

$$0 = \beta(\boldsymbol{\theta}) = \sum_k r_k \sin \theta_k = -\lambda \sum_k r_k \cos \theta_k \neq 0.$$

We deduce that the critical points of the function  $h$  are precisely the configurations  $\zeta = (\epsilon_1, \dots, \epsilon_n)$  such that  $\epsilon_k = \pm 1$  and  $\sum_{k=1}^n r_k \epsilon_k > 0$ . The corresponding configurations are the positions of the robot arm when all segments are parallel to the  $x$ -axis (see Figure 1.3). The critical configuration  $\zeta = (1, 1, \dots, 1)$  corresponds to the global maximum of  $h$  when the robot arm is stretched to its full length. We can be even more precise if we make the following generic assumption:

$$\sum_{k=1}^n r_k \epsilon_k \neq 0, \quad \forall \epsilon_1, \dots, \epsilon_n \in \{1, -1\}. \tag{1.1}$$

The above condition is satisfied if for example the numbers  $r_k$  are linearly independent over  $\mathbb{Q}$ . This condition is also satisfied when the length of the longest segment of the arm is strictly greater than the sum of the lengths of the remaining segments.

The assumption (1.1) implies that for any choice of  $\epsilon_k = \pm 1$  the sum  $\sum_k r_k \epsilon_k$  is never zero. We deduce that half of all the possible choices of  $\epsilon_k$  lead to a positive  $\sum_k r_k \epsilon_k$ , so that the number of critical points is  $c(n) = 2^{n-1}$ .  $\square$

If  $M$  is a smooth manifold,  $X$  is a vector field on  $M$ , and  $f$  is a smooth function, then we define the derivative of  $f$  along  $X$  to be the function

$$Xf = df(X).$$

**Lemma 1.6.** *Suppose  $f : M \rightarrow \mathbb{R}$  is a smooth function and  $p_0 \in M$  is a critical point of  $f$ . Then for every vector fields  $X, X', Y, Y'$  on  $M$  such that*

$$X(p_0) = X'(p_0), \quad Y(p_0) = Y'(p_0),$$

*we have*

$$(XYf)(p_0) = (X'Y')f(p_0) = (YXf)(p_0).$$

*Proof.* Note first that

$$(XY - YX)f(p_0) = ([X, Y]f)(p_0) = df([X, Y])(p_0) = 0.$$

Since  $(X - X')(p_0) = 0$ , we deduce that

$$(X - X')g(p_0) = 0, \quad \forall g \in C^\infty(M).$$

Hence

$$(X - X')Yf(p_0) = 0 \implies (XYf)(p_0) = (X'Yf)(p_0).$$

Finally,

$$(X'Yf)(p_0) = (YX'f)(p_0) = (Y'X'f)(p_0) = (X'Y'f)(p_0). \quad \square$$

If  $p_0$  is a critical point of the smooth function  $f : M \rightarrow \mathbb{R}$ , then we define the *Hessian* of  $f$  at  $p_0$  to be the map

$$H_{f,p_0} : T_{p_0}M \times T_{p_0}M \rightarrow \mathbb{R}, \quad H_{f,p_0}(X_0, Y_0) = (XYf)(p_0),$$

where  $X, Y$  are vector fields on  $X$  such that  $X(p_0) = X_0, Y(p_0) = Y_0$ . The above lemma shows that the definition is independent of the choice of vector fields  $X, Y$  extending  $X_0$  and  $Y_0$ . Moreover,  $H_{f,p_0}$  is bilinear and symmetric.

**Definition 1.7.** A critical point  $p_0$  of a smooth function  $f : M \rightarrow \mathbb{R}$  is called nondegenerate if its Hessian is nondegenerate, i.e.

$$H_{f,p_0}(X, Y) = 0, \quad \forall Y \in T_{p_0}M \iff X = 0.$$

A smooth function is called a Morse function if all its critical points are nondegenerate.  $\square$

Note that if we choose local coordinates  $(x^1, \dots, x^n)$  near  $p_0$  such that  $x^i(p_0) = 0, \forall i$ , then any vector fields  $X, Y$  have local descriptions

$$X = \sum_i X^i \partial_{x^i}, \quad Y = \sum_j Y^j \partial_{x^j}$$

near  $p_0$ , and we can write

$$H_{f,p_0}(X, Y) = \sum_{i,j} h_{ij} X^i Y^j, \quad h_{ij} = (\partial_{x^i} \partial_{x^j} f)(p_0).$$

The critical point is nondegenerate if and only if  $\det(h_{ij}) \neq 0$ . For example, the point  $B$  in Figure 1.1 is a degenerate critical point.

The Hessian also determines a function defined in a neighborhood of  $p_0$ ,

$$H_{f,p_0}(x) = \sum_{i,j} h_{ij} x^i x^j,$$

which appears in the Taylor expansion of  $f$  at  $p_0$ ,

$$f(x) = f(p_0) + \frac{1}{2}H_{f,p_0}(x) + O(3).$$

Let us recall a classical fact of linear algebra.

If  $V$  is a real vector space of finite dimension  $n$  and  $b : V \times V \rightarrow \mathbb{R}$  is a symmetric, bilinear nondegenerate map, then there exists at least one basis  $(e_1, \dots, e_n)$  such that for any  $v = \sum_i v^i e_i$  we have

$$b(v, v) = -(|v^1|^2 + \dots + |v^\lambda|^2) + |v^{\lambda+1}|^2 + \dots + |v^n|^2.$$

The integer  $\lambda$  is independent of the basis of  $(e_i)$ , and we will call it the index of  $b$ . It can be defined equivalently as the largest integer  $\ell$  such that there exists an  $\ell$ -dimensional subspace  $V_-$  of  $V$  with the property that the restriction of  $b$  to  $V_-$  is negative definite.

**Definition 1.8.** Suppose  $p_0$  is a nondegenerate critical point of a smooth function  $f : M \rightarrow \mathbb{R}$ . Then its index, denoted by  $\lambda(f, p_0)$ , is defined to be the index of the Hessian  $H_{f,p_0}$ .  $\square$

If  $f : M \rightarrow \mathbb{R}$  is a Morse function with finitely many critical points, then we define the Morse polynomial of  $f$  to be

$$P_f(t) = \sum_{p \in \text{Cr}_f} t^{\lambda(f,p)} =: \sum_{\lambda \geq 0} \mu_f(\lambda) t^\lambda.$$

Observe that the coefficient  $\mu_f(\lambda)$  is equal to the number of critical points of  $f$  of index  $\lambda$ . The coefficients of the Morse polynomial are known as the Morse numbers of the Morse function  $f$ .

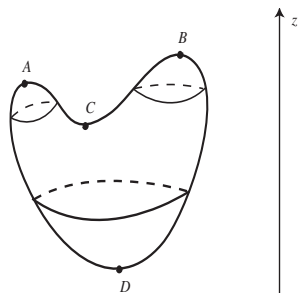

**Fig. 1.4.** A Morse function on the 2-sphere.

**Example 1.9.** Consider the hypersurface  $S \subset \mathbb{R}^3$  depicted in Figure 1.4. This hypersurface is diffeomorphic to the 2-sphere. The height function  $z$  on  $\mathbb{R}^3$  restricts to a Morse function on  $S$ .

This Morse function has four critical points labeled  $A, B, C, D$  in Figure 1.4. Their Morse indices are

$$\lambda(A) = \lambda(B) = 2, \quad \lambda(C) = 1, \quad \lambda(D) = 0,$$

so that the Morse polynomial is

$$t^{\lambda(A)} + t^{\lambda(B)} + t^{\lambda(C)} + t^{\lambda(D)} = 2t^2 + t + 1. \quad \square$$

**Example 1.10 (*Robot arms: index computations*).** Consider again the setup in Example 1.5. We have a smooth function  $h : C \rightarrow \mathbb{R}$ , where

$$C = \left\{ (z_1, \dots, z_n) \in (S^1)^n; \quad \mathbf{Re} \sum_k r_k z_k > 0, \quad \mathbf{Im} \sum_k r_k z_k = 0 \right\},$$

and

$$h(z_1, \dots, z_n) = \mathbf{Re} \sum_k r_k z_k.$$

Under the assumption (1.1) this function has  $2^{n-1}$  critical points  $\zeta$  described by

$$\zeta = (\zeta_1, \dots, \zeta_n) = (\epsilon_1, \dots, \epsilon_n), \quad \epsilon_k = \pm 1, \quad \sum_k r_k \epsilon_k > 0.$$

We want to prove that  $h$  is a Morse function and then compute its Morse polynomial. We write

$$\zeta_k = e^{i\varphi_k}, \quad \varphi_k \in \{0, \pi\}.$$

A point  $\mathbf{z} = (e^{i\theta_1}, \dots, e^{i\theta_n}) \in C$  close to  $\zeta$  is described by angular coordinates

$$\theta_k = \varphi_k + t_k, \quad |t_k| \ll 1,$$

satisfying the constraint

$$g(t_1, \dots, t_n) = \sum_{k=1}^n r_k \sin(\varphi_k + t_k) = 0.$$

Near  $\zeta$  the function  $g$  has the Taylor expansion

$$g(t_1, \dots, t_n) = \sum_{k=1}^n \epsilon_k r_k t_k + O(3),$$

where  $O(r)$  denotes an error term smaller than some constant multiple of  $(|t_1| + \dots + |t_n|)^r$ . We deduce that the Hessian of  $h|_C$  at  $\zeta$  can be identified with the restriction of the quadratic form

$$q(t_1, \dots, t_n) = - \sum_{k=1}^n \epsilon_k r_k t_k^2$$

to the subspace

$$T_{\zeta}C = \ker dg(\zeta) = \left\{ (t_1, \dots, t_n) \in \mathbb{R}^n; \sum_{k=1}^n \epsilon_k r_k t_k = 0 \right\}.$$

At this point we need the following elementary result.

**Lemma 1.11.** *Let  $\mathbf{c} = (c_1, \dots, c_n) \in \mathbb{R}^n$  be such that*

$$c_1 \cdot c_2 \dots c_n \neq 0, \quad S := c_1 + \dots + c_n \neq 0.$$

*Let  $V := \{ \mathbf{t} \in \mathbb{R}^n; \mathbf{t} \perp \mathbf{c} \}$  and define the quadratic form*

$$Q : \mathbb{R}^n \times \mathbb{R}^n \rightarrow \mathbb{R}, \quad Q(\mathbf{u}, \mathbf{v}) = \sum_{k=1}^n c_k u_k v_k.$$

*Then the restriction of  $Q$  to  $V$  is nondegenerate and*

$$\lambda(Q|_V) = \begin{cases} \lambda(Q), & S > 0, \\ \lambda(Q) - 1, & S < 0. \end{cases}$$

*Proof.* We may assume without any loss of generality that  $|\mathbf{c}| = 1$ . Denote by  $P_V$  the orthogonal projection onto  $V$  and set

$$L : \mathbb{R}^n \rightarrow \mathbb{R}^n, \quad L := \text{Diag}(c_1, \dots, c_n).$$

Then

$$Q(\mathbf{u}, \mathbf{v}) = (L\mathbf{u}, \mathbf{v}).$$

The restriction of  $Q$  to  $V$  is described by

$$Q|_V(\mathbf{v}_1, \mathbf{v}_2) = (P_V L \mathbf{v}_1, \mathbf{v}_2), \quad \forall \mathbf{v}_i \in V.$$

We deduce that  $Q|_V$  is nondegenerate if and only if the linear operator  $T = P_V L : V \rightarrow V$  has trivial kernel. Observe that  $\mathbf{v} \in V$  belongs to  $\ker T$  if and only if there exists a scalar  $y \in \mathbb{R}$  such that

$$L\mathbf{v} = y\mathbf{c} \iff \mathbf{v} = y\boldsymbol{\delta}, \quad \boldsymbol{\delta} := (1, \dots, 1).$$

Since  $(\mathbf{v}, \mathbf{c}) = 0$  and  $(\boldsymbol{\delta}, \mathbf{c}) = \sum_{k=1}^n c_k = S \neq 0$  we deduce  $y = 0$ , so that  $\mathbf{v} = 0$ . Note that since  $(\boldsymbol{\delta}, \mathbf{c}) \neq 0$  we have

$$V \cap \mathbb{R}\boldsymbol{\delta} = 0, \quad V + \mathbb{R}\boldsymbol{\delta} = (\mathbb{R}\mathbf{c})^\perp + \mathbb{R}\boldsymbol{\delta} = \mathbb{R}^n.$$

For  $\mathbf{v} \in V$  and  $y \in \mathbb{R}$  we have

$$(L(\mathbf{v} + y\boldsymbol{\delta}), \mathbf{v} + y\boldsymbol{\delta}) = (L\mathbf{v}, \mathbf{v}) + 2y(L\mathbf{v}, \boldsymbol{\delta}) + y^2(L\boldsymbol{\delta}, \boldsymbol{\delta}) = (L\mathbf{v}, \mathbf{v}) + y^2 S. \quad (1.2)$$

Suppose  $V_{\pm}$  is a maximal subspace of  $V$ , where  $Q|_V$  is positive/negative definite, so that

$$V_+ + V_- = V \quad (\implies \dim V_+ + \dim V_- = \dim V = n - 1).$$

Set

$$U_{\pm} = V_{\pm} \oplus \mathbb{R}\delta.$$

Observe that

$$\dim U_{\pm} = \dim V_{\pm} + 1, \quad V_+ \oplus U_- = \mathbb{R}^n = U_+ \oplus V_-. \quad (1.3)$$

We now distinguish two cases.

**A.**  $S > 0$ . Using equation (1.2) we deduce that  $Q$  is positive definite on  $U_+$  and negative definite on  $V_-$ . The equalities (1.3) imply that

$$\lambda(Q) = \dim V_- = \lambda(Q|_V).$$

**B.**  $S < 0$ . Using equation (1.2) we deduce that  $Q$  is positive definite on  $V_+$  and negative definite on  $U_-$ . The equalities (1.3) imply that

$$\lambda(Q) = \lambda(Q|_V) + 1.$$

This completes the proof of Lemma 1.11.  $\square$

Returning to our index computation we deduce that at a critical configuration  $\epsilon = (\epsilon_1, \dots, \epsilon_n)$  the Hessian of  $h$  is equal to the restriction of the quadratic form

$$Q = \sum_{k=1}^n c_k t_k^2, \quad c_k = -\epsilon_k r_k, \quad \sum_{k=1}^n c_k = -h(\epsilon) < 0,$$

to the orthogonal complement of  $\mathbf{c}$ . Lemma 1.11 now implies that this Hessian is nondegenerate and its index is

$$\lambda(\epsilon) = \lambda_h(\epsilon) = \#\{k; \epsilon_k = 1\} - 1. \quad (1.4)$$

For different approaches to the index computation we refer to [Hau, SV].

If (1.1) is satisfied we can obtain more refined information about the Morse polynomial of  $h$ . For every binary vector  $\epsilon \in \{-1, 1\}^n$  we define

$$\sigma(\epsilon) := \#\{k; \epsilon_k = 1\}, \quad \ell(\epsilon) = \sum_k \epsilon_k, \quad \rho(\epsilon) = \sum_k r_k \epsilon_k.$$

We deduce

$$2\sigma(\epsilon) = \sum_k \epsilon_k + \sum_k |\epsilon_k| = \ell(\epsilon) + n$$

$$\implies \lambda(\epsilon) = \frac{1}{2}(n + \ell(\epsilon)) - 1.$$

The set of critical points of  $h$  can be identified with the set

$$R_+ := \{ \epsilon \in \{-1, 1\}^n; \rho(\epsilon) > 0 \}.$$

Define

$$R_- = \{ \epsilon; -\epsilon \in R_+ \}.$$

Assumption (1.1) implies that

$$\{-1, 1\}^n = R_+ \sqcup R_-.$$

The Morse polynomial of  $h$  is

$$P_h(t) = \sum_{\epsilon \in R_+} t^{\lambda(\epsilon)} = t^{\frac{n}{2}-1} \sum_{\epsilon \in R_+} t^{\ell(\epsilon)/2}.$$

Define

$$L_h^+(t) := \sum_{\epsilon \in R_+} t^{\ell(\epsilon)/2}, \quad L_h^-(t) := \sum_{\epsilon \in R_-} t^{\ell(\epsilon)/2}.$$

Since  $\ell(-\epsilon) = -\ell(\epsilon)$  we deduce

$$L_h^-(t) = L_h^+(t^{-1}).$$

On the other hand,

$$L_h^+(t) + L_h^-(t) = \sum_{\epsilon} (t^{1/2})^{\ell(\epsilon)} = (t^{1/2} + t^{-1/2})^n = t^{-n/2}(t+1)^n.$$

Hence

$$L_h^+(t) + L_h(t^{-1}) = t^{-n/2}(t+1)^n.$$

Since

$$L_h^+(t) = t^{-n/2+1}P_h(t),$$

we deduce

$$t^{-n/2+1}P_h(t) + t^{n/2-1}P_h(t^{-1}) = t^{-n/2}(t+1)^n,$$

so that

$$tP_h(t) + t^{n-1}P_h(t^{-1}) = (t+1)^n. \quad (1.5)$$

Observe that  $t^{n-1}P(t^{-1})$  is the Morse polynomial of  $-h$ , so that

$$tP_h(t) + P_{-h}(t) = (t+1)^n. \quad (1.6)$$

If

$$P_h(t) = a_0 + a_1t + \dots + a_{n-1}t^{n-1},$$

then we deduce from (1.5) that

$$a_k + a_{n-2-k} = \binom{n}{k+1}, \quad \forall k = 1, \dots, n-2, \quad a_{n-1} = 1. \quad \square$$

Let us return to our general study of Morse functions. The key algebraic reason for their effectiveness in topological problems stems from their local rigidity. More precisely, the Morse functions have a very simple local structure: up to a change of coordinates all Morse functions are quadratic. This is the content of our next result, commonly referred to as the *Morse lemma*.

**Theorem 1.12 (Morse).** *Suppose  $f : M \rightarrow \mathbb{R}$  is a smooth function,  $m = \dim M$ , and  $p_0$  is a nondegenerate critical point of  $f$ . Then there exists an open neighborhood  $U$  of  $p_0$  and local coordinates  $(x^1, \dots, x^m)$  on  $U$  such that*

$$x^i(p_0) = 0, \quad \forall i = 1, \dots, m \quad \text{and} \quad f(x) = f(p_0) + \frac{1}{2}H_{f,p_0}(x).$$

*In other words,  $f$  is described in these coordinates by a quadratic polynomial.*

*Proof.* We use the approach in [AGV1, §6.4] based on the *homotopy method*. This has the advantage that it applies to more general situations. Assume for simplicity that  $f(p_0) = 0$ .

Fix a diffeomorphism  $\Phi$  from  $\mathbb{R}^m$  onto an open neighborhood  $N$  of  $p_0$  such that  $\Phi(0) = p_0$ . This diffeomorphism defines coordinates  $(x^i)$  on  $N$  such that  $x^i(p_0) = 0, \forall i$ , and we set  $\varphi(x) = f(\Phi(x))$ . For  $t \in [0, 1]$  define  $\varphi_t : \mathbb{R}^m \rightarrow \mathbb{R}$  by

$$\varphi_t(x) = (1-t)\varphi(x) + tQ(x) = Q(x) + (1-t)(\varphi(x) - Q(x)), \quad (1.7)$$

where

$$Q(x) = \frac{1}{2} \sum_{i,j} \frac{\partial^2 \varphi}{\partial x^i \partial x^j}(0) x^i x^j.$$

We seek an open neighborhood  $U$  of  $0 \in \mathbb{R}^m$  and a one-parameter family of embeddings  $\Psi_t : U \hookrightarrow \Phi^{-1}(N) = \mathbb{R}^m$  such that

$$\Psi_0 = \mathbb{1}, \quad \Psi_t(0) = 0, \quad \varphi_t(\Psi_t(y)) = \varphi(y) \quad \forall y \in U, \quad \forall t \in [0, 1]. \quad (1.8)$$

Such a family is uniquely determined by the  $t$ -dependent vector field

$$V_t(\Psi_t(y)) := \frac{d}{dt} \Psi_t(y).$$

More precisely, the path  $t \mapsto \Psi_t(y) \in \mathbb{R}^m$  is the unique solution of the initial value problem

$$\dot{\gamma}_y(t) = V_t(\gamma_y(t)) \quad \forall t, \quad \gamma_y(0) = y.$$

We set  $\dot{\varphi}_t := \partial_t \varphi_t = Q - \varphi$ . Differentiating (1.8) with respect to  $t$ , we deduce the *homology equation*

$$\dot{\varphi}_t \circ \Psi_t + V_t(\varphi_t \circ \Psi_t) = 0 \stackrel{(1.7)}{\iff} \varphi - Q = V_t \varphi_t \quad \text{on } \Psi_t(U), \quad \forall t \in [0, 1].$$



If we find a vector field  $V_t$  satisfying  $V_t(0) = 0, \forall t \in [0, 1]$  and

$$\varphi - Q = V_t \varphi_t \quad (1.9)$$

on a neighborhood  $W$  of 0, then

$$\mathcal{N} = \bigcap_{t \in [0,1]} \Psi_t^{-1}(W)$$

is a neighborhood<sup>1</sup> of 0, and we deduce that  $\Psi_t$  satisfies (1.8) on  $\mathcal{N}$ . To do this we need to introduce some terminology.

Two smooth functions  $f, g$  defined in a neighborhood of  $0 \in \mathbb{R}^m$  are said to be equivalent at 0 if there exists a neighborhood  $U$  of 0 such that  $f|_U = g|_U$ . The equivalence class of such a function  $f$  is called the *germ of the function* at 0 and it is denoted by  $[f]$ . We denote by  $\mathcal{E}$  the collection of germs at 0 of smooth functions. It is naturally an  $\mathbb{R}$ -algebra. The evaluation map

$$C^\infty \ni f \mapsto f(0) \in \mathbb{R}$$

induces a surjective morphism of rings  $\mathcal{E} \rightarrow \mathbb{R}$ . Its kernel is therefore a *maximal ideal* in  $\mathcal{E}$ , which we denote by  $\mathfrak{m}$ . It is easy to see that  $\mathcal{E}$  is a local ring, since for any function  $f$  such that  $f(0) \neq 0$ , the inverse  $1/f$  is smooth near zero.

**Lemma 1.13 (Hadamard).** *The ideal  $\mathfrak{m}$  is generated by the germs of the coordinate functions  $x^i$ .*

*Proof.* It suffices to show that  $\mathfrak{m} \subset \sum_i x^i \mathcal{E}$ . Consider a germ in  $\mathfrak{m}$  represented by the smooth function  $f$  defined in an open ball  $B_r(0)$ . Then for every  $x \in B_r(0)$  we have

$$f(x) - f(0) = \int_0^1 \frac{d}{ds} f(sx) ds = \sum_i x^i \underbrace{\int_0^1 \frac{\partial f}{\partial x^i}(sx) ds}_{=: u_i}.$$

This proves that  $[f] = \sum_i [x^i][u_i]$ . □

For every multi-index  $\alpha = (\alpha_1, \dots, \alpha_m) \in \mathbb{Z}_{\geq 0}^m$  we set

$$|\alpha| := \sum_i \alpha_i, \quad x^\alpha := (x^1)^{\alpha_1} \dots (x^m)^{\alpha_m}, \quad D^\alpha = \frac{\partial^{|\alpha|}}{(\partial x^1)^{\alpha_1} \dots (\partial x^m)^{\alpha_m}}.$$

**Lemma 1.14.** *If  $(D^\alpha f)(0) = 0$  for all  $|\alpha| < k$  then  $[f] \in \mathfrak{m}^k$ . In particular  $[\varphi] \in \mathfrak{m}^2, \varphi - Q \in \mathfrak{m}^3$ .*

<sup>1</sup> This happens because the condition  $V_t(0) = 0 \forall t$  implies that there exists  $r > 0$  with the property that  $\Psi_t(x) \in W, \forall |x| < r, \forall t \in [0, 1]$ . Loosely speaking, if a point  $x$  is not very far from the stationary point 0 of the flow  $\Psi_t$ , then in one second it cannot travel very far along this flow.

*Proof.* We argue by induction on  $k \geq 1$ . The case  $k = 1$  follows from the definition of  $\mathfrak{m}$ . Suppose now that  $(D^\alpha f)(0) = 0$  for all  $|\alpha| < k$ . By induction we deduce that  $[f] \in \mathfrak{m}^{k-1}$ , and Hadamard's lemma implies

$$f = \sum_{|\alpha|=k-1} x^\alpha u_\alpha, \quad u_\alpha \in \mathcal{E}.$$

Hence, for any multi-index  $\beta$  such that  $|\beta| = k - 1$ , we have

$$D^\beta f = D^\beta \left( \sum_{|\alpha| \leq k-1} x^\alpha u_\alpha \right) \in u_\beta + \mathfrak{m}.$$

In other words,

$$D^\beta f - u_\beta \in \mathfrak{m}, \quad \forall |\beta| = k - 1.$$

Since  $(D^\beta f)(0) = 0$ , we deduce from Hadamard's lemma that  $D^\beta f \in \mathfrak{m}$  so that  $u_\beta \in \mathfrak{m}$  for all  $\beta$ .  $\square$

Denote by  $J_\varphi$  the ideal in  $\mathcal{E}$  generated by the germs at 0 of the partial derivatives  $\partial_{x^i} \varphi$ ,  $i = 1, \dots, m$ . It is called the *Jacobian ideal* of  $\varphi$  at 0. Since 0 is a critical point of  $\varphi$ , we have  $J_\varphi \subset \mathfrak{m}$ . Because 0 is a *nondegenerate* critical point, we have an even stronger result.

**Lemma 1.15 (Key lemma).**  $J_\varphi = \mathfrak{m}$ .

*Proof.* We present a proof based on the implicit function theorem. Consider the smooth map

$$y = d\varphi : \mathbb{R}^m \rightarrow \mathbb{R}^m, \quad y = (y^1(x), \dots, y^m(x)), \quad y^i = \partial_i \varphi.$$

Then

$$y(0) = 0, \quad \frac{\partial y}{\partial x} \Big|_{x=0} = H_{\varphi,0}.$$

Since  $\det H_{\varphi,0} \neq 0$ , we deduce from the implicit function theorem that  $y$  is a local diffeomorphism. Hence its components  $y^i$  define local coordinates near  $0 \in \mathbb{R}^m$  such that  $y^i(0) = 0$ . We can thus express the  $x^i$ 's as smooth functions of  $y^j$ 's,  $x^i = x^i(y^1, \dots, y^m)$ .

On the other hand,  $x^i(y)|_{y=0} = 0$ , so we can conclude from Hadamard's lemma that there exist smooth functions  $u_j^i = u_j^i(y)$  such that

$$x^i = \sum_j u_j^i y^j \implies x^i \in J_\varphi, \quad \forall i. \quad \square$$

Set  $\delta := \varphi - Q$ , so that  $\varphi_t = \varphi - t\delta$ . We rewrite the homology equation (1.9) as

$$V_t \cdot (\varphi - t\delta) = \delta.$$

For every  $g \in \mathcal{E}$  we consider the "initial value" problem

$$V_t(0) = 0, \quad \forall t \in [0, 1], \quad (\mathbf{I})$$

$$V_t \cdot (\varphi - t\delta) = g, \quad \forall t \in [0, 1]. \quad (\mathbf{H}_g)$$

**Lemma 1.16.** *For every  $g \in \mathfrak{m}$  there exists a smooth vector field  $V_t$  satisfying  $(\mathbf{H}_g)$  for any  $t \in [0, 1]$ . Moreover, if  $g \in \mathfrak{m}^2$  we can find a solution  $V_t$  of  $(\mathbf{H}_g)$  satisfying the initial condition  $(\mathbf{I})$  as well.*

*Proof.* We start with some simple observations. Observe that if  $V_t^{g_i}$  is a solution of  $(\mathbf{H}_{g_i})$ ,  $i = 0, 1$ , and  $u_i \in \mathcal{E}$ , then  $u_0 V_t^{g_0} + u_1 V_t^{g_1}$  is a solution of  $(\mathbf{H}_{u_0 g_0 + u_1 g_1})$ . Since every  $g \in \mathfrak{m}$  can be written as a linear combination

$$g = \sum_{i=1}^m x^i u_i, \quad u_i \in \mathcal{E},$$

it suffices to find solutions  $V_t^i$  of  $(\mathbf{H}_{x^i})$ .

Using the key lemma we can find  $a_{ij} \in \mathcal{E}$  such that

$$x^i = \sum_j a_{ij} \partial_j \varphi, \quad \partial_j := \partial_{x^j}.$$

We can write this in matrix form as

$$x = A(x) \nabla \varphi \iff x = A(x) \nabla(\varphi - t\delta) + tA(x) \nabla \delta. \quad (1.11)$$

Lemma 1.14 implies  $\delta \in \mathfrak{m}^3$ , so that  $\partial_i \delta \in \mathfrak{m}^2$ ,  $\forall i$ . Thus we can find  $b_{ij} \in \mathfrak{m}$  such that

$$\partial_i \delta = \sum_j b_{ij} x^j,$$

or in matrix form,

$$\nabla \delta = Bx, \quad B(0) = 0.$$

Substituting this in (1.11), we deduce

$$(\mathbb{1}_{\mathbb{R}^m} - tA(x)B(x))x = A(x) \nabla(\varphi - t\delta).$$

Since  $B(0) = 0$ , we deduce that  $(\mathbb{1}_{\mathbb{R}^m} - tA(x)B(x))$  is invertible<sup>2</sup> for every  $t \in [0, 1]$  and every sufficiently small  $x$ . We denote by  $C_t(x)$  its inverse, so that we obtain

$$x = C_t(x)A(x) \nabla(\varphi - t\delta).$$

If we denote by  $V_j^i(t, x)$  the  $(i, j)$  entry of  $C_t(x)A(x)$ , we deduce

$$x^i = \sum_j V_j^i(t, x) \partial_j(\varphi - t\delta),$$

so the vector field

$$V_t^i = \sum_j V_j^i(t, x) \partial_j$$

---

<sup>2</sup> The reader familiar with the basics of commutative algebra will most certainly recognize that this step of the proof is in fact Nakayama's lemma in disguise.

is a solution of  $(\mathbf{H}_{x^i})$ . If  $g = \sum_i g_i x^i \in \mathfrak{m}$ , then  $\sum_i g_i V_t^i$  is a solution of  $(\mathbf{H}_g)$ . If additionally  $g \in \mathfrak{m}^2$ , then we can choose the previous  $g_i$  to be in  $\mathfrak{m}$ . Then  $\sum_i g_i V_t^i$  is a solution of  $(\mathbf{H}_g)$  satisfying the initial condition  $(\mathbf{I})$ .  $\square$

Now observe that since  $\delta \in \mathfrak{m}^3 \subset \mathfrak{m}^2$ , we can find a solution  $V_t$  of  $\mathbf{H}_\delta$  satisfying the “initial” condition  $(\mathbf{I})$ . This vector field is then a solution of the homology equations (1.9). This completes the proof of Theorem 1.12.  $\square$

**Corollary 1.17 (Morse lemma).** *If  $p_0$  is a nondegenerate critical point of index  $\lambda$  of a smooth function  $f : M \rightarrow \mathbb{R}$ , then there exist local coordinates  $(x^i)_{1 \leq i \leq m}$  near  $p_0$  such that  $x^i(p_0) = 0, \forall i$ , and in these coordinates we have the equality*

$$f = f(p_0) - \sum_{i=1}^{\lambda} (x^i)^2 + \sum_{j=\lambda+1}^m (x^j)^2. \quad \square$$

We will refer to coordinates with the properties in the Morse lemma as *coordinates adapted to the critical point*. If  $(x^1, \dots, x^m)$  are such coordinates, we will often use the notation

$$x = (x_-, x_+), \quad x_- = (x^1, \dots, x^\lambda), \quad x_+ = (x^{\lambda+1}, \dots, x^m),$$

$$f = f(p_0) - |x_-|^2 + |x_+|^2.$$

## 1.2 Existence of Morse Functions

The second key reason for the topological versatility of Morse functions is their abundance. It turns out that they form a dense open subset in the space of smooth functions. The goal of this section is to prove this claim.

The strategy we employ is very easy to describe. We will produce families of smooth functions  $f_\lambda : M \rightarrow \mathbb{R}$ , depending smoothly on the parameter  $\lambda \in A$ , where  $A$  is a smooth finite dimensional manifold. We will then produce a smooth map  $\pi : Z \rightarrow A$  such that  $f_\lambda$  is a Morse function for every regular value of  $\pi$ . Sard’s theorem will then imply that  $f_\lambda$  is a Morse function for most  $\lambda$ ’s.

Suppose  $M$  is a connected, smooth,  $m$ -dimensional manifold. According to Whitney’s embedding theorem (see, e.g., [W, IV.A]) we can assume that  $M$  is embedded in an Euclidean vector space  $E$  of dimension  $n \leq 2m + 1$ . We denote the metric on  $E$  by  $(\bullet, \bullet)$ . Suppose  $A$  is a smooth manifold and  $F : A \times E \rightarrow \mathbb{R}$  is a smooth function. We regard  $F$  as a smooth family of functions

$$F_\lambda : E \rightarrow \mathbb{R}, \quad F_\lambda(x) = F(\lambda, x), \quad \forall (\lambda, x) \in A \times E.$$

We set

$$f := F|_{A \times M}, \quad f_\lambda := F_\lambda|_M.$$

Let  $x \in M$ . There is a natural surjective linear map  $P_x : E^* \rightarrow T_x^*M$  which associates to each linear functional on  $E$  its restriction to  $T_xM \subset E$ . In particular, we have an equality

$$df_\lambda(x) = P_x dF_\lambda(x).$$

For every  $x \in M$  we have a smooth partial differential map

$$\partial^x f : A \rightarrow T_x^*M, \quad \lambda \mapsto df_\lambda(x).$$

**Definition 1.18.** (a) We say that the family  $F : A \times E \rightarrow \mathbb{R}$  is sufficiently large relative to the submanifold  $M \hookrightarrow E$  if the following hold:

- $\dim A \geq \dim M$ .
- For every  $x \in M$ , the point  $0 \in T_x^*M$  is a regular value for  $\partial^x f$ .

(b) We say that  $F$  is large if for every  $x \in E$  the partial differential map

$$\partial^x F : A \rightarrow E^*, \quad \lambda \mapsto dF_\lambda(x)$$

is a submersion, i.e., its differential at any  $\lambda \in A$  is surjective.  $\square$

**Lemma 1.19.** If  $F : A \times E \rightarrow \mathbb{R}$  is large, then it is sufficiently large relative to any submanifold  $M \hookrightarrow E$ .

*Proof.* From the equality  $\partial^x f = P_x \partial^x F$  we deduce that  $\partial^x f$  is a submersion as a composition of two submersions. In particular, it has no critical values.  $\square$

**Example 1.20.** (a) Suppose  $A = E^*$  and  $H : E^* \times E \rightarrow \mathbb{R}$ ,

$$H(\lambda, x) = \lambda(x), \quad \forall (\lambda, x) \in E^* \times E.$$

Using the metric identification we deduce that

$$d_x H_\lambda = \lambda, \quad \forall \lambda \in E^*.$$

Hence

$$\partial^x H : E^* \rightarrow T_x^*E = E^*$$

is the identity map and thus it is a submersion. Hence  $H$  is a large family.

(b) Suppose  $E$  is a Euclidean vector space with metric  $(\bullet, \bullet)$ ,  $A = E$ , and

$$R : E \times E \rightarrow \mathbb{R}, \quad R(\lambda, x) = \frac{1}{2}|x - \lambda|^2.$$

Then  $R$  is large. To see this, denote by  ${}^\dagger E \rightarrow E^*$  the metric duality. Note that

$$d_x R_\lambda = (x - \lambda)^\dagger,$$

and the map  $E \ni \lambda \mapsto (x - \lambda)^\dagger \in E^*$  is an affine isomorphism. Thus  $R$  is a large family.

(c) Suppose  $E$  is an Euclidean space. Denote by  $\Lambda$  the space of positive definite symmetric endomorphisms  $A : E \rightarrow E$  and define

$$F : \Lambda \times E \rightarrow \mathbb{R}, \quad \Lambda \times E \ni (A, x) \mapsto \frac{1}{2}(Ax, x).$$

Observe that  $\partial^x F : \Lambda \rightarrow E^*$  is given by

$$\partial^x F(A) = (Ax)^\dagger, \quad \forall A \in \Lambda.$$

If  $x \neq 0$ , then  $\partial^x F$  is onto. This shows that  $F$  is sufficiently large relative to any submanifold of  $E$  not passing through the origin.  $\square$

**Theorem 1.21.** *If the family  $F : \Lambda \times E \rightarrow \mathbb{R}$  is sufficiently large relative to the submanifold  $M \hookrightarrow E$ , then there exists a negligible set  $\Lambda_\infty \subset \Lambda$  such that, for all  $\lambda \in \Lambda \setminus \Lambda_\infty$ , the function  $f_\lambda : M \rightarrow \mathbb{R}$  is a Morse function.*

*Proof.* We will carry the proof in several steps.

**Step 1.** We assume that  $M$  is *special*, i.e., there exist *global* coordinates

$$(x^1, \dots, x^n)$$

on  $E$  (not necessarily linear coordinates) such that  $M$  can be identified with an open subset  $W$  of the coordinate “plane”

$$\{x^{m+1} = \dots = x^n = 0\}.$$

For every  $\lambda \in \Lambda$  we can then regard  $f_\lambda$  as a function  $f_\lambda : W \rightarrow \mathbb{R}$  and its differential as a function

$$\varphi_\lambda : W \rightarrow \mathbb{R}^m, \quad w = (x^1, \dots, x^m) \mapsto \varphi_\lambda(w) = (\partial_{x^1} f_\lambda(w), \dots, \partial_{x^m} f_\lambda(w)).$$

A point  $w \in W$  is a nondegenerate critical point of  $f_\lambda$  if

$$\varphi_\lambda(w) = 0 \in \mathbb{R}^m$$

and

the differential  $D\varphi_\lambda : T_w W \rightarrow \mathbb{R}^m$  is bijective.

We deduce that  $f_\lambda$  is a Morse function if and only if 0 is a regular value of  $\varphi_\lambda$ . Consider now the function

$$\Phi : \Lambda \times W \rightarrow \mathbb{R}^m, \quad \Phi(\lambda, w) = \varphi_\lambda(w).$$

The condition that the family be sufficiently large implies the following fact.

**Lemma 1.22.**  $0 \in \mathbb{R}^m$  is a regular value of  $\Phi$ , i.e., for every  $(\lambda, w) \in \Phi^{-1}(0)$  the differential  $D\Phi : T_{(\lambda, w)}A \times W \rightarrow \mathbb{R}^m$  is onto.

To keep the flow of arguments uninterrupted we will present the proof of this result after we have completed the proof of the theorem. We deduce that

$$Z = \Phi^{-1}(0) = \{ (\lambda, w) \in A \times W; \varphi_\lambda(w) = 0 \},$$

is a closed smooth submanifold of  $A \times V$ . The natural projection  $\pi : A \times W \rightarrow A$  induces a smooth map  $\pi : Z \rightarrow A$ . We have the following key observation.

**Lemma 1.23.** If  $\lambda$  is a regular value of  $\pi : Z \rightarrow A$ , then  $0$  is a regular value of  $\varphi_\lambda$ , i.e.,  $f_\lambda$  is a Morse function.

*Proof.* Suppose  $\lambda$  is a regular value of  $\pi$ . If  $\lambda$  does not belong to  $\pi(Z)$  the function  $f_\lambda$  has no critical points on  $M$ , and in particular, it is a Morse function.

Thus, we have to prove that for every  $w \in W$  such that  $\varphi_\lambda(w) = 0$ , the differential  $D\varphi_\lambda : T_w W \rightarrow \mathbb{R}^m$  is surjective. Set

$$T_1 := T_\lambda A, \quad T_2 = T_w W, \quad V = \mathbb{R}^m,$$

$$D_1 : D_\lambda \Phi : T_1 \rightarrow V, \quad D_2 = D_w \Phi : T_2 \rightarrow V.$$

Note that  $D\Phi = D_1 + D_2$ ,  $z = (\lambda, w) \in Z$ , and

$$T_z Z = \ker(D_1 + D_2 : T_1 \oplus T_2 \rightarrow V).$$

The lemma is then a consequence of the following linear algebra fact.

- Suppose  $T_1, T_2, V$  are finite dimensional real vector spaces and

$$D_i : T_i \rightarrow V, \quad i = 1, 2,$$

are linear maps such that  $D_1 + D_2 : T_1 \oplus T_2 \rightarrow V$  is surjective and the restriction of the natural projection

$$P : T_1 \oplus T_2 \rightarrow T_1$$

to  $K = \ker(D_1 + D_2)$  is surjective. Then  $D_2$  is surjective.

Indeed, let  $v \in V$ . Then there exists  $(t_1, t_2) \in T_1 \oplus T_2$  such that  $v = D_1 t_1 + D_2 t_2$ . On the other hand, since  $P : K \rightarrow T_1$  is onto, there exists  $t'_2 \in T_2$  such that  $(t_1, t'_2) \in K$ . Note that

$$v = D_1 t_1 + D_2 t_2 - (D_1 t_1 + D_2 t'_2) = D_2(t_2 - t'_2) \implies v \in \mathbf{Im} D_2. \quad \square$$

Using the Morse–Sard–Federer theorem we deduce that the set  $\Lambda_M \subset A$  of critical values of  $\pi : Z \rightarrow A$  is negligible, i.e., it has measure zero (see

Definition 1.1). Thus, for every  $\lambda \in \Lambda \setminus \Lambda_M$  the function  $f_\lambda : M \rightarrow \mathbb{R}$  is a Morse function. This completes Step 1.

**Step 2.**  $M$  is general. We can then find a countable open cover  $(M_k)_{k \geq 1}$  of  $M$  such that  $M_k$  is special  $\forall k \geq 1$ . We deduce from Step 1 that for every  $k \geq 1$  there exists a negligible set  $A_k \subset \Lambda$  such that for every  $\lambda \in \Lambda \setminus A_k$  the restriction of  $f_\lambda$  to  $M_k$  is a Morse function. Set

$$\Lambda_\infty = \bigcup_{k \geq 1} A_k.$$

Then  $\Lambda_\infty$  is negligible, and for every  $\lambda \in \Lambda \setminus \Lambda_\infty$  the function  $f_\lambda : M \rightarrow \mathbb{R}$  is a Morse function. The proof of the theorem will be completed as soon as we prove Lemma 1.22.

**Proof of Lemma 1.22.** We have to use the fact that the family  $F$  is sufficiently large relative to  $M$ . This condition is equivalent to the fact that if  $(\lambda_0, w_0)$  is such that  $\varphi_{\lambda_0}(w_0) = 0$ , then the differential

$$D_\lambda \Phi = \frac{\partial}{\partial \lambda} \Big|_{\lambda=\lambda_0} df_\lambda(w_0) : T_{\lambda_0} \Lambda \rightarrow \mathbb{R}^m$$

is onto. A fortiori, the differential  $D\Phi : T_{(\lambda_0, w_0)}(\Lambda \times W) \rightarrow \mathbb{R}^m$  is onto.  $\square$

**Definition 1.24.** A continuous function  $g : M \rightarrow \mathbb{R}$  is called *exhaustive* if all the sublevel sets  $\{g \leq c\}$  are compact.  $\square$

Using Lemma 1.19 and Example 1.20 we deduce the following result.

**Corollary 1.25.** Suppose  $M$  is a submanifold of the Euclidean space  $E$  not containing the origin. Then for almost all  $v \in E^*$ , almost all  $p \in E$ , and almost any positive symmetric endomorphism  $A$  of  $E$  the functions

$$h_v, r_p, q_A : M \rightarrow \mathbb{R},$$

defined by

$$h_v(x) = v(x), \quad r_p(x) = \frac{1}{2}|x - p|^2, \quad q_A(x) = \frac{1}{2}(Ax, x),$$

are Morse functions. Moreover, if  $M$  is closed as a subset of  $E$  then the functions  $r_p$  and  $q_A$  are exhaustive.  $\square$

**Corollary 1.26.** Suppose that  $M$  is smooth manifold and  $\mathbf{U} \subset C^\infty(M)$  is a finite dimensional vector space satisfying the ampleness condition

$$\forall p \in M, \quad \forall \xi \in T_p^* M, \quad \exists u \in \mathbf{U} : \quad du(p) = \xi.$$

Then almost any function  $u \in \mathbf{U}$  is Morse.



*Proof.* Fix an embedding  $i_0 : M \rightarrow E_0$  into a finite dimensional vector space  $E_0$ . Denote by  $\mathbf{U}^*$  the dual of  $\mathbf{U}$ ,  $\mathbf{U}^* := \text{Hom}(\mathbf{U}, \mathbb{R})$ , and define

$$i : M \rightarrow E_0 \oplus \mathbf{U}^*, \quad M \ni x \mapsto i_0(x) \oplus \mathbf{e}\mathbf{v}_x \in E_0 \oplus \mathbf{U}^*,$$

where  $\mathbf{e}\mathbf{v}_x : \mathbf{U} \rightarrow \mathbb{R}$  is given by

$$\mathbf{e}\mathbf{v}_x(u) = u(x), \quad \forall u \in \mathbf{U}.$$

The map  $i$  is an embedding. Set  $E := E_0 \oplus \mathbf{U}^*$  and define

$$F : \mathbf{U} \times E \rightarrow \mathbb{R}, \quad \mathbf{U} \times (E_0 \oplus \mathbf{U}^*) \ni (u, e_0 \oplus u^*) \mapsto u^*(u).$$

Note that for any  $x \in M$  and any  $u \in \mathbf{U}$  we have

$$F(u, i(x)) = \mathbf{e}\mathbf{v}_x(u) = u(x),$$

so that  $F_u|_M = u, \forall u \in \mathbf{U}$ . Hence

$$\partial^x f : \mathbf{U} \rightarrow T_x M, \quad u \mapsto du(x).$$

The ampleness condition implies that  $F$  is large relative to the submanifold  $i(M)$  of  $E$  and the result follows from Theorem 1.21.  $\square$

*Remark 1.27.* (a) Although the examples of Morse functions described in Corollary 1.25 may seem rather special, one can prove that any Morse function on a compact manifold is of the type  $h_v$ . Indeed, let  $M$  be a compact smooth manifold, and  $f : M \rightarrow \mathbb{R}$  be a Morse function on  $M$ . Fix an embedding  $\Phi : M \hookrightarrow \mathbb{R}^n$ . We can then define another embedding

$$\Phi_f : M \hookrightarrow \mathbb{R} \times \mathbb{R}^n, \quad x \mapsto (f(x), \Phi(x)).$$

If  $(\mathbf{e}_0, \mathbf{e}_1, \dots, \mathbf{e}_n)$  denotes the canonical basis in  $\mathbb{R} \times \mathbb{R}^n$ , then we see that  $f$  can be identified with the height function  $h_{\mathbf{e}_0}$ , i.e.,

$$f = h_{\mathbf{e}_0} \circ \Phi_f = (\Phi_f)^* h_{\mathbf{e}_0}.$$

(b) The Whitney embedding theorem states something stronger: any smooth manifold of dimension  $m$  can be embedded as a *closed* subset of an Euclidean space of dimension at most  $2m + 1$ . We deduce that any smooth manifold admits *exhaustive* Morse functions.

(c) Note that an exhaustive smooth function satisfies the *Palais–Smale condition*: any sequence  $x_n \in M$  such that  $f(x_n)$  is bounded from above and  $|df(x_n)|_g \rightarrow 0$  contains a subsequence convergent to a critical point of  $f$ . Here  $|df(x)|_g$  denotes the length of  $df(x) \in T_x^* M$  with respect to some fixed Riemannian metric on  $M$ .  $\square$

**Definition 1.28.** A Morse function  $f : M \rightarrow \mathbb{R}$  is called resonant if there exist two distinct critical points  $p, q$  corresponding to the same critical value, i.e.,  $f(p) = f(q)$ . If different critical points correspond to different critical values then  $f$  is called nonresonant<sup>3</sup>.  $\square$

It is possible that a Morse function  $f$  constructed in this corollary may be resonant. We want to show that any Morse function can be arbitrarily well approximated in the  $C^2$ -topology by nonresonant ones.

Consider a smooth function  $\eta : [0, \infty) \rightarrow [0, 1]$  satisfying the conditions

$$\eta(0) = 1, \quad \eta(t) = 0, \quad \forall t \geq 2, \quad -1 \leq \eta'(t) \leq 0, \quad \forall t \geq 0.$$

We set

$$\eta_\varepsilon(t) = \varepsilon^3 \eta(\varepsilon^{-1}t).$$

Observe that

$$\eta_\varepsilon(0) = \varepsilon, \quad -\varepsilon^2 \leq \eta'_\varepsilon(t) \leq 0.$$

Suppose  $f : M \rightarrow \mathbb{R}$  is a smooth function and  $p$  is a nondegenerate critical point of  $f$ ,  $f(p) = c$ . Fix coordinates  $x = (x_-, x_+)$  adapted to  $p$ . Hence

$$f = c - |x_-|^2 + |x_+|^2, \quad \forall x \in U_\varepsilon = \{|x_-|^2 + |x_+|^2 < 2\varepsilon\}.$$

Set  $u_\pm = |x_\pm|^2$ ,  $u = u_- + u_+$  and define

$$f_\varepsilon = f_{\varepsilon,p} = f + \eta_\varepsilon(u) = c - u_- + u_+ + \eta_\varepsilon(u).$$

Then  $f = f_\varepsilon$  on  $X \setminus U_\varepsilon$ , while along  $U_\varepsilon$  we have

$$df_\varepsilon = (\eta'_\varepsilon - 1)du_- + (\eta'_\varepsilon + 1)du_+.$$

This proves that the only critical point of  $f_{\pm\varepsilon}|_{U_\varepsilon}$  is  $x = 0$ . Thus  $f_{\pm\varepsilon,p}$  has the same critical set as  $f$ , and

$$\|f - f_\varepsilon\|_{C^2} \leq \varepsilon, \quad f_\varepsilon(p) = f(p) + \varepsilon^3, \quad f_\varepsilon(q) = f(q), \quad \forall q \in \mathbf{Cr}_f \setminus \{p\}.$$

Iterating this procedure, we deduce the following result.

**Proposition 1.29.** Suppose  $f : M \rightarrow \mathbb{R}$  is a Morse function on the compact manifold  $M$ . Then there exists a sequence of nonresonant Morse functions  $f_n : M \rightarrow \mathbb{R}$  with the properties

$$\mathbf{Cr}_{f_n} = \mathbf{Cr}(f), \quad \forall n, \quad f_n \xrightarrow{C^2} f, \quad \text{as } n \rightarrow \infty. \quad \square$$

*Remark 1.30.* The nonresonant Morse functions on a compact manifold  $M$  enjoy a certain stability that we want to describe.

<sup>3</sup> R. Thom refers to our non-resonant Morse functions as *excellent*.

We declare two smooth functions  $f_0, f_1 : M \rightarrow \mathbb{R}$  to be equivalent if and only if there exist diffeomorphisms  $R : M \rightarrow M$  and  $L : \mathbb{R} \rightarrow \mathbb{R}$  such that  $f_1 = L \circ f_0 \circ R^{-1}$ , i.e., the diagram below is commutative

$$\begin{array}{ccc} M & \xrightarrow{f_0} & \mathbb{R} \\ R \downarrow & & \downarrow L \\ M & \xrightarrow{f_1} & \mathbb{R} \end{array}$$

In other words, two smooth functions are to be equivalent if one can be obtained from the other via a global change of coordinates  $R$  on  $M$  and a global change of coordinates  $L$  on  $\mathbb{R}$ .

We can give an alternate, more conceptual formulation of this condition. Consider the group  $\mathcal{G} = \text{Diff}(M) \times \text{Diff}(\mathbb{R})$ , where  $\text{Diff}(X)$  denotes the group of smooth diffeomorphisms of the smooth manifold  $X$ . The group  $\mathcal{G}$  acts (on the left) on the space  $C^\infty(M, \mathbb{R})$  of smooth functions on  $M$ , according to the rule

$$(R, L) * f := L \circ f \circ R^{-1},$$

$\forall (R, L) \in \text{Diff}(M) \times \text{Diff}(\mathbb{R}), f \in C^\infty(M, \mathbb{R})$ . Two smooth functions are therefore equivalent if and only if they belong to the same orbit of the above action of  $\mathcal{G}$ .

The space  $C^\infty(M, \mathbb{R})$  is equipped with a natural locally convex topology making it a Fréchet space (see [GG, Chap. III]) so that a sequence of functions converges in this topology if and only if the sequences of partial derivatives converge uniformly on  $M$ . A function  $f \in C^\infty(M, \mathbb{R})$  is said to be *stable* if it admits an open neighborhood  $\mathcal{O}$  in the above topology on  $C^\infty(M, \mathbb{R})$  such that any  $g \in \mathcal{O}$  is equivalent to  $f$ .

One can prove (see [GG, Thm. III.2.2]) that a function  $f \in C^\infty(M, \mathbb{R})$  is stable if and only if it is a nonresonant Morse function.  $\square$

### 1.3 Morse Functions on Knots

As we have explained in Remark 1.27(a), any Morse function on a compact manifold  $M$  can be viewed as a height function  $h_v$  with respect to some suitable embedding of  $M$  in an Euclidean space  $\mathbf{E}$  and some vector  $v \in \mathbf{E}$ .

In this section we look at the simplest case, an embedding of  $S^1$  in the 3-dimensional Euclidean space and we would like to understand the size of the critical set of such a height function. Since we have one height function for each unit vector, it is natural to ask what is the “average size” of the critical set such a height function. The answer turns out to depend both on the geometry and the topology of the embedding. A byproduct of this analysis is a celebrated result of J. Milnor [M0] concerning the “amount of twisting” it takes to knot a curve. Our presentation is inspired from [CL].

We define a *knot* to be a smooth embedding  $\phi : S^1 \hookrightarrow \mathbf{E}$ , where  $\mathbf{E}$  is an *oriented* real Euclidean 3-dimensional space, with inner product  $(-, -)$ . We denote by  $K$  the image of this embedding. Let  $\mathbf{S}$  denote the unit sphere in  $\mathbf{E}$ .

A vector  $\mathbf{v} \in \mathbf{S}$  determines a linear map

$$\ell_{\mathbf{v}} : \mathbf{E} \rightarrow \mathbb{R}, \quad \mathbf{x} \mapsto (\mathbf{v}, \mathbf{x}).$$

We set

$$h_{\mathbf{v}} := \ell_{\mathbf{v}}|_K.$$

As explained in the previous section, for almost all  $\mathbf{v}$  in  $\mathbf{S}$ , the function  $h_{\mathbf{v}}$  is Morse. We denote by  $\mu_K(\mathbf{v})$  the number of critical points of  $h_{\mathbf{v}}$ . If  $h_{\mathbf{v}}$  is not a Morse function we set  $\mu_K(\mathbf{v}) := 0$ . Observe that if  $h_{\mathbf{v}}$  is Morse, then  $\mu_K(\mathbf{v}) \geq 2$  because a Morse function on a circle has at least two critical points, an absolute minimum and an absolute maximum.

We want to show that the function

$$\mathbf{S} \ni \mathbf{v} \mapsto \mu_K(\mathbf{v}) \in \mathbb{Z}$$

is measurable, and then compute its average

$$\bar{\mu}_K := \frac{1}{\text{area}(\mathbf{S})} \int_{\mathbf{S}} \mu_K(\mathbf{v}) dA(\mathbf{v}) = \frac{1}{4\pi} \int_{\mathbf{S}} \mu_K(\mathbf{v}) dA(\mathbf{v}),$$

where  $dA$  denotes the Euclidean area element on the unit sphere.

The proof relies on a special case of classical result in geometric measure theory called *the coarea formula*. While the statement of this result is very intuitive, its proof is rather technical. To keep the geometric arguments in this section as transparent as possible we decided to omit its the proof. The curious reader can consult [BZ, §13.4], [Fed, §3.2], or [Mor, §3.7].

The formulation of the area formula uses a geometric invariant that may not be as widely know so we begin by defining it.

Suppose  $(M_0, g_0)$  and  $(M_1, g_1)$  are smooth, connected, Riemannian manifolds of identical dimension  $m$ , and  $F : M_0 \rightarrow M_1$  is a smooth map. We do not assume that either one of these manifolds is orientable. The *Jacobian* of  $F$  is the smooth nonnegative function

$$|J_F| : M_0 \rightarrow [0, \infty)$$

defined as follows. Let  $x_0 \in M_0$ , set  $x_1 = F(x_0)$  and denote by  $\dot{F}_{x_0}$  the differential of  $F$  at  $x_0$  so that  $\dot{F}_{x_0}$  is a linear map

$$\dot{F}_{x_0} : T_{x_0}M_0 \rightarrow T_{x_1}M_1.$$

Fix an orthonormal basis  $(\mathbf{e}_1, \dots, \mathbf{e}_m)$  of  $T_{x_0}M_0$ , and set

$$\mathbf{f}_k := \dot{F}_{x_0} \mathbf{e}_k, \quad 1 \leq k \leq m.$$

We can form the  $m \times m$  symmetric matrix  $G_F(x_0)$  whose  $(i, j)$ -th entry is the inner product  $g_1(\mathbf{f}_i, \mathbf{f}_j)$ . In a more compact form, the matrix  $G_F(x_0)$  represents in the orthonormal basis  $(\mathbf{e}_i)$  the linear operator

$$\dot{F}_{x_0}^* \dot{F}_{x_0} T_{x_0} M \rightarrow T_{x_0} M.$$

This shows that the matrix  $G_f(x_0)$  is nonnegative so its determinant is non-negative, and it is independent of the choice of orthonormal basis  $(\mathbf{e}_k)$ . Then

$$|J_F|(x_0) := \sqrt{\det G_F(x_0)}.$$

If both  $M_0$  and  $M_1$  are *oriented*, then we can give an alternate description of the Jacobian. The orientations define volume *forms*  $dV_{g_0} \in \Omega^m(M_0)$  and  $dV_{g_1} \in \Omega^m(M_1)$ . There exists a smooth function  $w_F : M_0 \rightarrow \mathbb{R}$  uniquely determined by the condition

$$F^* dV_{g_1} = w_F dV_{g_0}.$$

Then

$$|J_F|(x_0) = |w_F(x_0)|, \quad \forall x_0 \in M_0.$$

Observe that if  $F : M_0 \rightarrow M_1$  is a smooth map between compact smooth manifolds of identical dimensions, then Sard's theorem implies that for almost every  $x_1 \in M_1$  is a regular value of  $F$ . For such  $x_1$ 's the fiber  $F^{-1}(x_1)$  is a finite set. We denote by  $N_F(x_1) \in \mathbb{Z}_{\geq 0} \cup \{\infty\}$  its cardinality. We can now formulate the very special case of the coarea formula that we need in this section.

**Theorem 1.31 (Corea formula).** *Suppose  $F : (M_0, g_0) \rightarrow (M_1, g_1)$  is a smooth map between two compact, connected oriented Riemann manifolds of identical dimensions. Then the function*

$$M_1 \ni x_1 \mapsto N_F(x_1) \in \mathbb{Z}_{\geq 0} \cup \{\infty\}$$

*is measurable with respect to the Lebesgue measure defined by  $dV_{g_1}$ , and*

$$\int_{M_1} N_F(x_1) dV_{g_1}(x_1) = \int_{M_0} |J_F|(x_0) dV_{g_0}(x_0). \quad \square$$

We now return to our original investigation. The embedding  $\phi : S^1 \rightarrow \mathbf{E}$  defining  $K$  induces an orientation on  $K$ . For  $x \in K$  we denote by  $\mathbf{e}_0(x)$  the unit vector tangent to  $K$  at  $x$  and pointing in the direction given by the orientation. Define

$$\mathbf{S}(K) = \{ (x, \mathbf{v}) \in K \times \mathbf{S}; \mathbf{v} \perp \mathbf{e}_0(x) \}.$$

In other words,  $\mathbf{S}(K)$  is the unit sphere bundle associated to the normal bundle of  $K \hookrightarrow \mathbf{E}$ . The natural (left and right) projections

$$\lambda : K \times \mathbf{S} \rightarrow K, \quad \rho : K \times \mathbf{S} \rightarrow \mathbf{S}$$

induce smooth maps

$$\lambda_K : \mathbf{S}(K) \rightarrow K \quad \text{and} \quad \rho_K : \mathbf{S}(K) \rightarrow \mathbf{S}.$$

The first key observation is contained in the following lemma whose proof is left to the reader as an exercise (Exercise 6.5).

**Lemma 1.32.** *The vector  $\mathbf{v} \in \mathbf{S}$  is a regular value of the map  $\rho : \mathbf{S}(K) \rightarrow \mathbf{S}$  if and only if  $h_{\mathbf{v}} : K \rightarrow \mathbb{R}$  is a Morse function. Moreover*

$$\mu_K(\mathbf{v}) = N_{\rho_K}(\mathbf{v}), \quad \forall \mathbf{v} \in \mathbf{S}. \quad \square$$

We deduce from Theorem 1.31 that the function  $\mathbf{v} \mapsto \mu_K(\mathbf{v})$  is measurable, and

$$\bar{\mu}_K = \frac{1}{4\pi} \int_{\mathbf{S}} N_{\rho_K}(\mathbf{v}) dA(\mathbf{v}). \quad (1.12)$$

To evaluate the right-hand side of (1.12) we plan to use the coarea formula for the map  $\rho_K$ . This requires a choice of metric on  $\mathbf{S}(K)$ .

Denote by  $ds$  the length element along  $K$ , and by  $L$  the length of  $K$ . By fixing a point on  $K$  we obtain an arclength parametrization

$$[0, L] \ni s \mapsto x(s) \in K \subset \mathbf{E}.$$

Fix a smooth map  $\mathbf{e}_1 : K \rightarrow \mathbf{S}$  such that  $\mathbf{e}_1(x) \perp \mathbf{e}_0(x)$ ,  $\forall x \in K$ . In other words,  $\mathbf{e}_1$  is a section of the normal unit circle bundle  $\lambda_K : \mathbf{S}(K) \rightarrow K$ . We set

$$\mathbf{e}_2(x) := \mathbf{e}_0(x) \times \mathbf{e}_1(x),$$

where  $\times$  is the cross-product on  $\mathbf{E}$  induced by the metric and the orientation on this vector space. The collection  $(\mathbf{e}_0(x), \mathbf{e}_1(x), \mathbf{e}_2(x))$  is a so called *moving frame* along  $K$ . Observe that for any  $x \in K$  the collection  $(\mathbf{e}_1(x), \mathbf{e}_2(x))$  is an orthonormal basis of the normal plane  $(T_x K)^\perp \subset \mathbf{E}$ . We set

$$\mathbf{e}_j(s) := \mathbf{e}_j(x(s)), \quad j = 0, 1, 2.$$

We can now produce a diffeomorphism  $\psi : (\mathbb{R}/L\mathbb{Z}) \times (\mathbb{R}/2\pi\mathbb{Z}) \rightarrow \mathbf{S}(K)$

$$(\mathbb{R}/L\mathbb{Z}) \times (\mathbb{R}/2\pi\mathbb{Z}) \ni (s, \theta) \mapsto (x(s), \mathbf{v}(s, \theta)) \in \mathbf{S}(K),$$

$$\mathbf{v}(s, \theta) = \cos \theta \cdot \mathbf{e}_1(s) + \sin \theta \cdot \mathbf{e}_2(s).$$

We define the metric on  $\mathbf{S}(K)$  to be

$$g_K = ds^2 + d\theta^2.$$

Note that we have globally defined vector fields  $\partial_s$  and  $\partial_\theta$  on  $\mathbf{S}(K)$  that define an orthonormal frame of the tangent plane at each point of  $\mathbf{S}(K)$ . In the coordinates  $(s, \theta)$  the map  $\rho_K$  is described by

$$(s, \theta) \mapsto \mathbf{v}(s, \theta).$$

If we denote by  $|J_K|$  the Jacobian of the map

$$\rho_K : (\mathbf{S}(K), g_K) \rightarrow (\mathbf{S}, g_S)$$

then we deduce that

$$|J_K|^2 = \begin{vmatrix} (\mathbf{v}_s, \mathbf{v}_s)_{\mathbf{E}} & (\mathbf{v}_s, \mathbf{v}_\theta)_{\mathbf{E}} \\ (\mathbf{v}_s, \mathbf{v}_\theta)_{\mathbf{E}} & (\mathbf{v}_\theta, \mathbf{v}_\theta)_{\mathbf{E}} \end{vmatrix},$$

where  $\mathbf{v}_s$  and  $\mathbf{v}_\theta$  denote the partial derivatives with respect to  $s$  and  $\theta$  of the smooth map  $(s, \theta) \mapsto \mathbf{v}(s, \theta) \in \mathbf{E}$ . We have

$$\mathbf{v}_s = \cos \theta \cdot \mathbf{e}'_1(s) + \sin \theta \cdot \mathbf{e}'_2(s), \quad \mathbf{v}_\theta = -\sin \theta \cdot \mathbf{e}_1(s) + \cos \theta \cdot \mathbf{e}_2(s),$$

where a prime  $'$  indicates derivation with respect to  $s$ . Let us observe that

$$(\mathbf{v}_\theta, \mathbf{v}_\theta)_{\mathbf{E}} = 1.$$

For any  $0 \leq i, j \leq 2$  we have

$$(\mathbf{e}_i(s), \mathbf{e}_j(s))_{\mathbf{E}} = \begin{cases} 1, & i = j \\ 0, & i \neq j, \end{cases}$$

so that

$$(\mathbf{e}'_i(s), \mathbf{e}_j(s))_{\mathbf{E}} + (\mathbf{e}_i(s), \mathbf{e}'_j(s))_{\mathbf{E}} = 0, \quad \forall 0 \leq i, j \leq 2.$$

This shows that the  $s$  dependent matrix

$$A(s) = (a_{ij}(s))_{0 \leq i, j \leq 2}, \quad a_{ij}(s) = (\mathbf{e}_i(s), \mathbf{e}'_j(s))_{\mathbf{E}},$$

is skew-symmetric, so we can represent it as

$$A(s) = \begin{bmatrix} 0 & -\alpha(s) & -\beta(s) \\ \alpha(s) & 0 & -\gamma(s) \\ \beta(s) & \gamma(s) & 0 \end{bmatrix}.$$

We deduce

$$(\mathbf{v}_s, \mathbf{v}_\theta)_{\mathbf{E}} = (\mathbf{e}'_1(s), \mathbf{e}_2(s))_{\mathbf{E}} = a_{21}(s) = \gamma(s).$$

We have

$$\begin{aligned} \mathbf{v}_s &= \cos \theta (-\alpha(s) \mathbf{e}_0(s) + \gamma(s) \mathbf{e}_2(s)) + \sin \theta (-\beta(s) \mathbf{e}_0(s) - \gamma(s) \mathbf{e}_1(s)) \\ &= -(\alpha(s) \cos \theta + \beta(s) \sin \theta) \mathbf{e}_0(s) - \sin \theta \gamma(s) \mathbf{e}_1(s) + \cos \theta \gamma(s) \mathbf{e}_2(s) \end{aligned}$$

so that

$$(\mathbf{v}_s, \mathbf{v}_s)_{\mathbf{E}} = (\alpha(s) \cos \theta + \beta(s) \sin \theta)^2 + \gamma(s)^2.$$

We deduce that

$$|J_K|^2 = (\alpha(s) \cos \theta + \beta(s) \sin \theta)^2.$$

Using the area formula in (1.12) we deduce

$$\bar{\mu}_K = \frac{1}{4\pi} \int_0^L \underbrace{\left( \int_0^{2\pi} |\alpha(s) \cos \theta + \beta(s) \sin \theta| d\theta \right)}_{=: I(s)} ds. \quad (1.13)$$

To extract a geometrically meaningful information we need a more explicit description of the integral  $I(s)$ . This is achieved in our next lemma.

**Lemma 1.33.** *Let  $\mathbf{u} \in \mathbb{R}^2$ . For any  $\theta \in [0, 2\pi]$  we denote by  $\mathbf{n}(\theta)$  the outer normal to the unit circle in the plane at the point  $e^{i\theta}$ . Then*

$$I(\mathbf{u}) := \int_{S^1} |\mathbf{u} \cdot \mathbf{n}(\theta)| d\theta = 4|\mathbf{u}|,$$

where  $\cdot$  denotes the canonical inner product in  $\mathbb{R}^2$ .

*Proof.* Observe that for any rotation  $T : \mathbb{R}^2 \rightarrow \mathbb{R}^2$  we have  $I(T\mathbf{u}) = I(\mathbf{u})$  so we can assume that  $\mathbf{u} = re^{i\theta}$ ,  $\theta = 0$ ,  $r \geq 0$ . In this case we have

$$I(\mathbf{u}) = 2r \int_{-\pi/2}^{\pi/2} \cos \theta d\theta = 4r = 4|\mathbf{u}|. \quad \square$$

Now choose  $\mathbf{u} = (\alpha(s), \beta(s))$  in Lemma 1.33 to deduce that

$$I(s) = 4\sqrt{\alpha(s)^2 + \beta(s)^2} = 4|\mathbf{e}'_0(s)|.$$

The scalar  $|\mathbf{e}'_0(s)|$  is known as the (absolute) curvature of  $K$  at the point  $x(s)$  and it is denoted by  $|\kappa(s)|$ . We conclude

$$\frac{1}{4\pi} \int_{\mathcal{S}} \mu_K(\mathbf{v}) dA(\mathbf{v}) = \bar{\mu}_K = \frac{1}{\pi} \int_K |\kappa(s)| ds. \quad (1.14)$$

The integral  $\int_K |\kappa(s)| ds$  is called the *total curvature* of the knot, and it is denoted by  $T_K$ . It measures how “twisted” is the curve  $K$ . Large  $T_K$  signifies that  $K$  is very twisted. The above formula shows that if  $K$  is very twisted then the height function  $h_{\mathbf{v}}$  will have lots of critical points on  $K$ .

In [M0] the number

$$c_K = \frac{1}{2} \bar{\mu}_K$$

was called the *crookedness* of the knot. Observe that



$$c_K = \frac{1}{4\pi} \int_{\mathcal{S}} \frac{1}{2} \mu_K(\mathbf{v}) dA_{\mathbf{v}}.$$

Observing (Exercise 6.4) that on a circle the critical points of a Morse function are either local minima or local maxima and their numbers are equal, we conclude that  $\frac{1}{2}\mu_K(\mathbf{v})$  is the number of local minima of the Morse function  $h_{\mathbf{v}}$ . We deduce

$$c_k = \frac{1}{2\pi} T_K. \quad (1.15)$$

Here are some interesting consequences.

**Corollary 1.34.** *For any knot  $K \hookrightarrow \mathbf{E}$  we have  $T_K \geq 2\pi$ .*

*Proof.* Since any Morse function on  $K$  has at least two critical points, the equality (1.14) implies  $T_K \geq 2\pi$ .  $\square$

**Corollary 1.35.** *If  $K$  is planar and convex then  $T_K = 2\pi$ .*

*Proof.* Since  $K$  is convex, any local minimum of a height function must be an absolute minimum. Thus, any Morse height function will have a unique local minimum. This implies that the crookedness of  $K$  is 1. The corollary now follows from (1.15).  $\square$

*Remark 1.36.* A stronger result is true. More precisely, *Fenchel's theorem* states that if  $K$  is a knot, then  $T_K = 2\pi$  if and only if  $K$  is a planar convex curve. In Exercise 6.6 we indicate one strategy for proving this result.  $\square$

**Corollary 1.37 (Milnor).** *If  $T_K < 4\pi$ , then  $K$  is not knotted.*

*Proof.* We deduce that  $\mu_K < 4$ . Thus, there exists  $\mathbf{v} \in \mathcal{S}$  such that  $\mu_K(\mathbf{v}) < 4$ . Since  $\mu_K(\mathbf{v})$  is a positive even number we deduce that  $\mu_K(\mathbf{v}) = 2$ . Thus the function  $h_{\mathbf{v}}$  has only two critical points on  $K$ : a global minimum and a global maximum. We leave the reader as an exercise<sup>4</sup> to show that this implies that  $K$  is not knotted.  $\square$

We can turn the above result on its head and conclude that if the knot  $K$  is not the trivial knot, then its total curvature must be  $\geq 4\pi$ . In other words, a nontrivial knot must be twice twisted than a planar convex curve.

*Remark 1.38.* The results in this section can be given a probabilistic interpretation. More precisely, equip the three-dimensional Euclidean space  $\mathbf{E}$  with a *Gaussian* probability measure

$$d\gamma(\mathbf{v}) = (2\pi)^{-\frac{3}{2}} e^{-\frac{|\mathbf{v}|^2}{2}} d\mathbf{v}.$$

<sup>4</sup> See Exercise 6.22 and its solution on page 309.

The collection  $(\ell_{\mathbf{v}})_{\mathbf{v} \in \mathbf{E}}$  is an example of *random process*. The function

$$\mathbf{E} \ni \mathbf{v} \mapsto \mu_K(\mathbf{v}) \in \mathbb{Z}$$

is a random variable and one can prove that

$$\int_{\mathbf{E}} \mu_K(\mathbf{v}) d\gamma(\mathbf{v}) = \mu_K = \frac{1}{4\pi} \int_{\mathbf{S}} \mu_K(\mathbf{v}) dA(\mathbf{v}), \quad (1.16)$$

i.e., the expectation of this random variable is the equal to the crookedness of  $K$ . We refer to [Ni3] for a generalization of this probabilistic equality.  $\square$

---

## The Topology of Morse Functions

The present chapter is the heart of Morse *theory*, which is based on two fundamental principles. The “weak” Morse principle states that as long as the real parameter  $t$  varies in an interval containing only regular values of a smooth function  $f : M \rightarrow \mathbb{R}$ , then the topology of the sublevel set  $\{f \leq t\}$  is independent of  $t$ . We can turn this on its head and state that a change in the topology of  $\{f \leq t\}$  is an indicator of the presence of a critical point.

The “strong” Morse principle describes precisely the changes in the topology of  $\{f \leq t\}$  as  $t$  crosses a critical value of  $f$ . These changes are known in geometric topology as *surgery operations*, or *handle attachments*.

The surgery operations are more subtle than they first appear, and we thought it wise to devote an entire section to this topic. It will give the reader a glimpse at the potential “zoo” of smooth manifolds that can be obtained by an iterated application of these operations.

### 2.1 Surgery, Handle Attachment, and Cobordisms

To formulate the central results of Morse theory we need to introduce some topological terminology. Denote by  $\mathbb{D}^k$  the  $k$ -dimensional, *closed* unit disk and by  $\mathring{\mathbb{D}}^k$  its interior. We will refer to  $\mathbb{D}^k$  as the *standard  $k$ -cell*. The cell attachment technique is one of the most versatile methods of producing new topological spaces out of existing ones.

Given a topological space  $X$  and a continuous map  $\varphi : \partial\mathbb{D}^k \rightarrow X$ , we can attach a  $k$ -cell to  $X$  to form the topological space  $X \cup_{\varphi} \mathbb{D}^k$ . The compact spaces obtained by attaching finitely many cells to a point are homotopy equivalent to finite *CW*-complexes. We would like to describe a related operation in the more restricted category of *smooth* manifolds.

We begin with the operation of *surgery*. Suppose that  $M$  is a smooth  $m$ -dimensional manifold. The operation of surgery requires several additional data:

- an embedding  $S \hookrightarrow M$  of the standard  $k$ -dimensional sphere  $S^k$ ,  $k < m$ , with trivializable normal bundle  $T_S M$ ;
- a *framing* of the normal bundle  $T_S M$ , i.e., a bundle isomorphism

$$\varphi : T_S M \rightarrow \underline{\mathbb{R}}_S^{m-k} = \mathbb{R}^{m-k} \times S.$$

Equivalently, a framing of  $S$  defines an isotopy class of embeddings

$$\varphi : \mathbb{D}^{m-k} \times S^k \rightarrow M \text{ such that } \varphi(\{0\} \times S^k) = S.$$

Set  $U := \varphi(\mathring{\mathbb{D}}^{m-k} \times S^k)$ . Then  $U$  is a tubular neighborhood of  $S$  in  $M$ . We can now define a new *topological* manifold  $M(S, \varphi)$  by removing  $U$  and then gluing instead  $\hat{U} = S^{m-k-1} \times \mathbb{D}^{k+1}$  along  $\partial U = \partial(M \setminus U)$  via the identifications

$$\partial \hat{U} \xrightarrow{\varphi} \partial U = \partial(M \setminus U).$$

For every  $e_0 \in \partial \mathbb{D}^{m-k} = S^{m-k-1}$ , the sphere  $\varphi(e_0 \times S^k) \subset M$  will bound the disk  $e_0 \times \mathbb{D}^{k+1}$  in  $M(S, \varphi)$ . Note that  $e_0 \times S^k$  can be regarded as the graph of a section of the trivial bundle  $\mathbb{D}^{m-k} \times S^k \rightarrow S^k$ .

To see that  $M(S, \varphi)$  is indeed a smooth manifold we observe that

$$U \setminus S \cong (\mathring{\mathbb{D}}^{m-k} \setminus 0) \times S^k.$$

Using spherical coordinates we obtain diffeomorphisms

$$\begin{aligned} (\mathring{\mathbb{D}}^{m-k} \setminus 0) \times S^k &\cong (0, 1) \times S^{m-k-1} \times S^k, \\ S^{m-k-1} \times (0, 1) \times S^k &\cong S^{m-k-1} \times (\mathbb{D}^{k+1} \setminus 0). \end{aligned}$$

Now attach  $(S^{m-k-1} \times \mathbb{D}^{k+1})$  to  $U$  along  $U \setminus S$  using the obvious diffeomorphism

$$(0, 1) \times S^{m-k-1} \times S^k \rightarrow S^{m-k-1} \times (0, 1) \times S^k.$$

The diffeomorphism type of  $M(S, \varphi)$  depends on the isotopy class of the embedding  $S \hookrightarrow M$  and on the regular homotopy class of the framing  $\varphi$ . We say that  $M(S, \varphi)$  is obtained from  $M$  by a surgery of type  $(S, \varphi)$ .

**Example 2.1 (Zero dimensional surgery).** Suppose  $M$  is a smooth  $m$ -dimensional manifold consisting of two connected components  $M_{\pm}$ . A 0-dimensional sphere  $S^0$  consists of two points  $p_{\pm}$ . Fix an embedding  $S^0 \hookrightarrow M$  such that  $p_{\pm} \in M_{\pm}$ . Fix open neighborhoods  $U_{\pm}$  of  $p_{\pm} \in M_{\pm}$  diffeomorphic to  $\mathbb{D}^m$  and set  $U = U_- \cup U_+$ . Then

$$\partial(M \setminus U) \cong \partial U_- \cup \partial U_+ \cong S^0 \times S^{m-1}.$$

If we now glue  $\mathbb{D}^1 \times S^{m-1} = [-1, 1] \times S^{m-1}$  such that  $\{\pm 1\} \times S^{m-1}$  is identified with  $\partial U_{\pm}$ , we deduce that the surgery of  $M_- \cup M_+$  along the zero sphere  $\{p_{\pm}\}$  is diffeomorphic to the connected sum  $M_- \# M_+$ . Equivalently, we identify  $(-1, 0) \times S^{m-1} \subset \mathbb{D}^1 \times S^{m-1}$  with the punctured neighborhood  $U_- \setminus \{p_-\}$  (so that for  $s \in (-1, 0)$  the parameter  $-s$  is the radial distance in  $U_-$ ) and then identify  $(0, 1) \times S^{m-1}$  with the punctured neighborhood  $U_+ \setminus \{p_+\}$  (so that  $s \in (0, 1)$  represents the radial distance).  $\square$

**Example 2.2 (Codimension two surgery).** Suppose  $M^m$  is a compact, oriented smooth manifold  $m \geq 3$  and  $i : S^{m-2} \hookrightarrow M$  is an embedding of a  $(m-2)$ -sphere with trivializable normal bundle. Set  $S = i(S^{m-2})$ . The natural orientation on  $S^{m-2}$  (as boundary of the unit disk in  $\mathbb{R}^{m-1}$ ) induces an orientation on  $S$ . We have a short exact sequence

$$0 \rightarrow TS \rightarrow TM|_S \rightarrow T_S M \rightarrow 0$$

of vector bundles over  $S$ .

The orientation on  $S$  together with the orientation on  $M$  induce via the above sequence an orientation on the normal bundle  $T_S M$ . Fix a metric on this bundle and denote by  $\mathbb{D}_S M$  the associated unit disk bundle. Since the normal bundle has rank 2, the orientation on  $T_S M$  makes it possible to speak of *counterclockwise* rotations in each fiber. A trivialization is then uniquely determined by a choice of section

$$\mathbf{e} : S \rightarrow \partial\mathbb{D}_S M.$$

Given such a section  $\mathbf{e}$ , we obtain a positively oriented orthonormal frame  $(\mathbf{e}, \mathbf{f})$  of  $T_S M$ , where  $\mathbf{f}$  is obtained from  $\mathbf{e}$  by a  $\pi/2$  counterclockwise rotation. In particular, we obtain an embedding

$$\varphi_{\mathbf{e}} : \mathbb{D}^2 \times S^{m-2} \cong \mathbb{D}_S M \hookrightarrow M.$$

Once we fix such a section  $\mathbf{e}_0 : S \rightarrow \partial\mathbb{D}_S M$  we obtain a trivialization

$$\partial\mathbb{D}_S M \cong S^1 \times S,$$

and then any other framing is described by a smooth map  $S^{m-2} \rightarrow S^1$ . We see that the homotopy classes of framings are classified by  $\pi_{m-2}(S^1)$ . In particular, this shows that the choice of framing becomes relevant only when  $m = 3$ .

The surgery on the framed sphere  $(S, \mathbf{e}_0)$  has the effect of removing a tubular neighborhood  $U \cong \varphi_{\mathbf{e}_0}(\mathbb{D}^2 \times S^{m-2})$  and replacing it with the manifold  $\hat{U} = S^1 \times \mathbb{D}^{m-1}$ , which has identical boundary.

The section  $\mathbf{e}_0$  of  $\partial\mathbb{D}_S \rightarrow S$  traces a submanifold  $L_0 \subset \partial\mathbb{D}_S M$  diffeomorphic to  $S^{m-2}$ . Via the trivialization  $\varphi_{\mathbf{e}_0}$  it traces a sphere  $\varphi_{\mathbf{e}_0}(L_0) \subset \partial U$  called the *attaching sphere* of the surgery. After the surgery, this attaching sphere will bound the disk  $\{1\} \times \mathbb{D}^{m-1} \subset \hat{U}$ .  $\square$

**Example 2.3 (Surgery on knots in  $S^3$ ).** Suppose that  $M = S^3$  and that  $K$  is a smooth embedding of a circle  $S^1$  in  $S^3$ . Such embeddings are commonly referred to as *knots*.

A classical result of Seifert (see [Rolf, 5.A]) states that any such knot bounds an orientable Riemann surface  $X$  smoothly embedded in  $S^3$ . The interior-pointing unit normal along  $\partial X = K$  defines a nowhere vanishing section of the normal bundle  $T_K S^3$  and thus defines a framing of this bundle. This

is known as the *canonical framing*<sup>1</sup> of the knot. It defines a diffeomorphism between a tubular neighborhood  $U$  of the knot and the solid torus  $\mathbb{D}^2 \times S^1$ .

The canonical framing traces the curve

$$\ell = \ell_K = \{1\} \times S^1 \subset \partial\mathbb{D}^2 \times S^1.$$

The curve  $\ell$  is called the *longitude* of the knot, while the boundary  $\partial\mathbb{D}^2 \times \{1\}$  of a fiber of the normal disk bundle defines a curve called the *meridian* of the knot and denoted by  $\mu = \mu_K$ .

Any other framing of the normal bundle will trace a curve  $\varphi$  on  $\partial U \cong \partial\mathbb{D}^2 \times S^1$  isotopic inside  $U$  to the axis  $K = \{0\} \times S^1$  of the solid torus  $U$ . Thus in  $H_1(\partial\mathbb{D}^2 \times S^1, \mathbb{Z})$  it has the form

$$[\varphi] = p[\mu] + [\ell],$$

where the integer  $p$  is the winding number of  $\varphi$  in the meridional plane  $\mathbb{D}^2$ . The curve  $\varphi$  is called the *attaching curve* of the surgery.

The integer  $p$  completely determines the isotopy class of  $\varphi$ . Thus, every surgery on a knot in  $S^3$  is uniquely determined by an integer  $p$  called the *coefficient of the surgery*, and the surgery with this framing coefficient will be called *p-surgery*. We denote by  $S^3(K, p)$  the result of a  $p$ -surgery on the knot  $K$ .

The attaching curve of the surgery  $\varphi$  is a *parallel* of the knot  $K$ . By definition, a parallel of  $K$  is a knot  $K'$  located in a thin tubular neighborhood of  $K$  with the property that the radial projection onto  $K$  defines a homeomorphism  $K' \rightarrow K$ . Conversely, every parallel  $K'$  of the knot  $K$  can be viewed as the attaching curve of a surgery. The surgery coefficient is then the *linking number* of  $K$  and  $K'$ , denoted by  $\mathbf{lk}(K, K')$ .

When we perform a  $p$ -surgery on  $K$  we remove the solid torus  $U = \mathbb{D}^2 \times S^1$  and we replace it with a new solid torus  $\hat{U} = S^1 \times \mathbb{D}^2$ , so that in the new manifold the attaching curve  $K_p = \ell + p\mu$  will bound the disk  $\{1\} \times \mathbb{D}^2 \subset \hat{U}$ .

Let us look at a very simple yet fundamental example. Think of  $S^3$  as the round sphere

$$\{(z_0, z_1) \in \mathbb{C}^2; |z_0|^2 + |z_1|^2 = 2\}.$$

Consider the closed subsets  $U_i = \{(z_0, z_1) \in S^3; |z_i| \leq 1\}$ ,  $i = 0, 1$ . Observe that  $U_0$  is a solid torus via the diffeomorphism

$$U_0 \ni (z_0, z_1) \mapsto (z_0, \frac{z_1}{|z_1|}) \in \mathbb{D}^2 \times S^1.$$

Denote by  $K_i$  the knot in  $S^3$  defined by  $z_i = 0$ . For example,  $K_0$  admits the parametrization

$$[0, 1] \ni t \mapsto (0, \sqrt{2}e^{2\pi it}) \in S^3.$$

The knots  $K_0, K_1$  are disjoint and form the *Hopf link*. Both are unknotted (see Figure 2.1).

<sup>1</sup> Its homotopy class is indeed independent of the choice of the Seifert surface  $X$ .

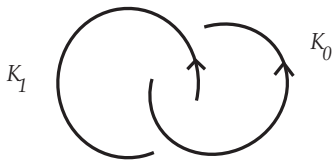

**Fig. 2.1.** The Hopf link.

For example,  $K_0$  bounds the embedded 2-disk

$$X_0 := \{\zeta \in \mathbb{C}; |\zeta|^2 \leq 2\} \hookrightarrow \{(z_0, z_1) = (\sqrt{2 - |\zeta|^2}, \zeta), \in S^3\}.$$

Observe that  $U_0$  is a tubular neighborhood of  $K_0$ , and the above isomorphism identifies it with the trivial 2-disk bundle, thus defining a framing of  $K_0$ . This framing is the canonical framing of  $U_0$ . The longitude of this framing is the curve

$$\ell_0 = \partial U_0 \cap X_0 = \{(1, e^{2\pi it}); t \in [0, 1]\}.$$

The meridian of  $K_0$  is the curve  $z_0 = e^{2\pi it}, z_1 = 1, t \in [0, 1]$ . Via the diffeomorphism

$$U_1 \rightarrow \mathbb{D}^2 \times S^1, \quad U_1 \ni (z_0, z_1) \mapsto \left( z_1, \frac{1}{|z_0|} z_0 \right) \in \mathbb{D}^2 \times S^1,$$

this curve can be identified with the *meridian*  $\mu_1$  of  $K_1$ .

Set  $M_p := S^3(K, p)$ . The manifold  $M_p$  is obtained by removing  $U_0$  from  $S^3$  and gluing back a solid torus  $\hat{U}_0 = S^1 \times \mathbb{D}^2$  to the complement of  $U_0$ , which is the solid torus  $U_1$ , so that

$$\partial \hat{U}_0 \supset \hat{\mu}_0 = \{1\} \times \partial \mathbb{D}^2 \longmapsto p[\mu_0] + [\ell_0] = p[\mu_0] + [\mu_1].$$

For  $p = 0$  we see that the disk  $\{1\} \times \partial \mathbb{D}^2 \in S^1 \times \mathbb{D}^2 = \hat{U}_0$  bounds a disk in  $\hat{U}_0$  and a meridional disk in  $U_1$ . The result of zero surgery on the unknot will then be  $S^1 \times S^2$ .

If  $p \neq 0$ , we can compute the fundamental group of  $M_p$  using the van Kampen theorem. Denote by  $T$  the torus  $\partial \hat{U}_0$ , by  $j_0$  the inclusion induced morphism  $\pi_1(T) \rightarrow \pi_1(\hat{U}_0)$ , and by  $j_1$  the inclusion induced morphism  $\pi_1(T) \rightarrow \pi_1(U_1)$ . As generators of  $\pi_1(T)$  we can choose  $\mu_0$  and the attaching curve of the surgery  $\varphi = \mu_0^p \ell_0$  because the intersection number of these two curves is  $\pm 1$ . As generator of  $\pi_1(U_1)$  we can choose  $\ell_1 = \mu_0$  because the longitude of  $K_1$  is the meridian of  $K_0$ . As generator of  $\pi_1(\hat{U}_0)$  we can choose  $j_0(\mu_0)$  because  $j_0$  is surjective and  $\varphi \in \ker j_0$ . Thus  $\pi_1(M_p)$  is generated by  $\mu_0, \varphi$  with the relation

$$1 = j_0(\hat{\mu}_0) = j_p(\hat{\mu}_0) = \mu_0^p \ell_0, \quad \ell_0 = j_0(\ell_0) = j_p(\ell_0), \quad j_p(\mu_0) = j_0(\mu_0).$$

Hence  $\pi_1(M_p) \cong \mathbb{Z}/p$ . In fact,  $M_p$  is a lens space. More precisely, we have an *orientation preserving* diffeomorphism

$$S^3(K_0, \pm|p|) \cong L(|p|, |p| \pm 1). \quad \square$$

**Example 2.4 (Surgery on the trefoil knot).** Suppose that  $K$  is a knot in  $S^3$ . Choose a closed tubular neighborhood  $U$  of  $K$ . The canonical framing of  $K$  defines a diffeomorphism  $U = \mathbb{D}^2 \times S^1$ . Denote by  $E_K$  the exterior

$$E_K = S^3 \setminus \text{int}(U).$$

Let  $T = \partial E_K = \partial U$ , and denote by  $i_* : \pi_1(T) \rightarrow \pi_1(E_K)$  the inclusion induced morphism. Let  $K' \subset T$  be a *parallel* of  $K$ , i.e., a simple closed curve that intersects a meridian  $\mu = \partial \mathbb{D}^2 \times \{pt\}$  of the knot exactly once.

The parallel  $K'$  determines a surgery on the knot  $K$  with surgery coefficient  $p = \mathbf{lk}(K, K')$ . To compute the fundamental group of  $S^3(K, p)$  we use as before the van Kampen theorem.

Suppose  $\pi_1(E_K)$  has a presentation with the set of generators  $\mathcal{G}_K$  and relations  $\mathcal{R}_K$ . Let  $\hat{U} = S^1 \times \mathbb{D}^2$  and denote by  $j$  the natural map

$$\partial U = \partial \mathbb{D}^1 \times S^1 \rightarrow S^1 \times \mathbb{D}^2 = \hat{U}.$$

Then  $\pi_1(\hat{U})$  is generated by  $\hat{\ell} = j_*(\mu)$  and we deduce that  $S^3(K, p)$  has a presentation with generators  $\mathcal{G} \cup \{\hat{\ell}\}$  and relation

$$i_*(K') = 1, \quad \hat{\ell} = j_*(\mu).$$

Equivalently, a presentation of  $S^3(K, p)$  is obtained from a presentation of  $\pi_1(E_K)$  by adding a single relation

$$i_*(K') = 1.$$

The fundamental group of the complement of the knot is called the *group of the knot*, and we will denote it by  $G_K$ . Let us explain how to compute a presentation of  $G_K$  and the morphism  $i_*$ .

Observe first that  $\pi_1(T)$  is a free Abelian group of rank 2. As basis of  $\pi_1(T)$  we can choose any pair  $(\mu, \gamma)$ , where  $\gamma$  is a parallel of  $K$  situated on  $T$ . Then we can write

$$K' = a\mu + b\gamma.$$

If  $w$  denotes the linking number of  $\gamma$  and  $K$ , and  $\ell$  denotes the longitude of  $K$ , then we can write  $\gamma = w\mu + \ell$ ,

$$K' = p\mu + \ell = a\mu + b(w\mu + \ell) \implies b = 1, \quad a = p - w, \quad K' = (p - w)\mu + \gamma.$$

Thus  $i_*$  is completely understood if we know  $i_*(\mu)$  and  $i_*(\gamma)$  for some parallel  $\gamma$  of  $K$ .

The group of the knot  $K$  can be given an explicit presentation in terms of the *knot diagram*. This algorithmic presentation is known as the *Wirtinger presentation*. We describe it the special case of the (left-handed) trefoil knot depicted in Figure 2.2 and we refer to [Rolf, III.A] for proofs.

The Wirtinger algorithm goes as follows.



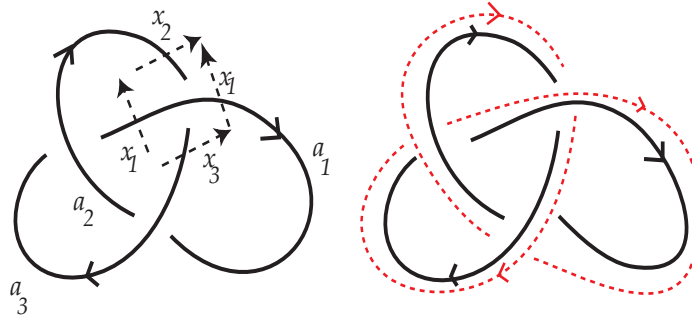

**Fig. 2.2.** The (left-handed) trefoil knot and its blackboard parallel.

- Choose an orientation of the knot and a basepoint  $*$  situated off the plane of the diagram. Think of the basepoint as the location of the eyes of the reader.
- The diagram of the knot consists of several disjoint arcs. Label them by

$$a_1, a_2, \dots, a_\nu,$$

in increasing cyclic order given by the above chosen orientation of the knot. In the case of the trefoil knot we have three arcs,  $a_1, a_2, a_3$ .

- To each arc  $a_k$  there corresponds a generator  $x_k$  represented by a loop starting at  $*$  and winding around  $a_k$  once in the positive direction, where the positive direction is determined by the right-hand rule: if you point your right-hand thumb in the direction of  $a_k$ , then the rest of your palm should be wrapping around  $a_k$  in the direction of  $x_k$  (see Figure 2.3).
- For each crossing of the knot diagram we have a relation. The crossings are of two types, positive (+) (or right-handed) and negative (−) (or left-handed) (see Figure 2.3). Label by  $i$  the crossing where the arc  $a_i$  begins and the arc  $a_{i-1}$  ends. Denote by  $a_{k(i)}$  the arc going over the  $i$ th crossing and set

$$\epsilon(i) = \pm 1 \text{ if } i \text{ is a } \pm\text{-crossing.}$$

Then the relation introduced by the  $i$ th crossing is

$$x_i = x_{k(i)}^{-\epsilon(i)} x_{i-1} x_{k(i)}^{\epsilon(i)}.$$

The knot diagram defines a parallel of  $K$  called the *blackboard parallel* and denoted by  $K_{bb}$ . It is obtained by tracing a contour parallel and very close to the diagram of  $K$  and situated to the left of  $K$  with respect to the chosen orientation. In Figure 2.2 the blackboard parallel of the trefoil knot is depicted with a thin line.

The linking number of  $K$  and  $K_{bb}$  is called the *writhe* of the knot diagram and it is denoted by  $w(K)$ . *It is not an invariant of the knot.* It is equal to the signed number of crossings of the diagram, i.e., the difference between the

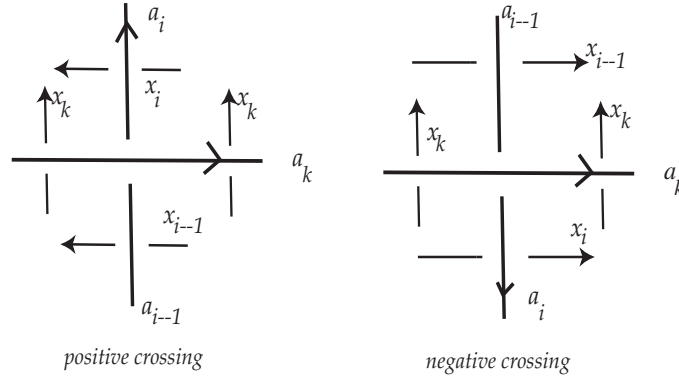

**Fig. 2.3.** The Wirtinger relations.

number of positive crossings and the number of negative crossings. One can show that

$$i_*(K_{bb}) = \prod_{i=1}^{\nu} x_{k(i)}^{\epsilon(i)}, \quad i_*(\mu) = x_{\nu}. \quad (2.1)$$

Set  $G = G_K$ , where  $K$  is the (left-handed) trefoil knot. In this case all the crossings in the diagram depicted in Figure 2.2 are negative and we have  $w(K) = -3$ . The group  $G$  has three generators  $x_1, x_2, x_3$ , and since all the crossings are negative we conclude that  $\epsilon(i) = -1, \forall i = 1, 2, 3$ , so that we have three relations

$$\begin{aligned} x_1 &= x_2 x_3 x_2^{-1} & x_2 &= x_3 x_1 x_3^{-1}, & x_3 &= x_1 x_2 x_1^{-1}, & (2.2) \\ k(1) &= 2, & k(2) &= 3, & k(3) &= 1. & (2.3) \end{aligned}$$

From the equalities (2.3) we deduce

$$c = i_*(K_{bb}) = x_2^{-1} x_3^{-1} x_1^{-1}, \quad i_*(\mu) = x_3. \quad (2.4)$$

For  $x \in G$  we denote by  $T_x : G \rightarrow G$  the conjugation  $g \mapsto xgx^{-1}$ . We deduce

$$x_i = T_{x_{k(i)}} x_{i-1}, \quad \forall i = 1, 2, 3 \implies x_3 = T_{x_{k(1)}^{-1} x_{k(2)}^{-1} x_{k(3)}^{-1}} x_3 = T_c x_3,$$

i.e.,  $x_3$  commutes with  $c = x_2^{-1} x_3^{-1} x_1^{-1}$ . Set for simplicity

$$a = x_1, \quad b = x_2, \quad x_3 = T_a b = aba^{-1}.$$

We deduce from (2.2) that  $G$  has the presentation

$$G = \langle a, b \mid aba = bab \rangle.$$

Consider the group

$$H = \langle x, y \mid x^3 = y^2 \rangle.$$

We have a map

$$H \rightarrow G, \quad x \mapsto ab, \quad y \mapsto aba.$$

It is easily seen to be a morphism with inverse  $a = x^{-1}y$ ,  $b = a^{-1}x = y^{-1}x^2$  so that  $G \cong H$ .

If we perform  $-1$  surgery on the (left handed) trefoil knot, then the attaching curve of the surgery is isotopic to

$$K' = -1 - w\mu + K_{bb}, \quad w = \text{lk}(K_{bb}, \ell) = -3,$$

and we conclude

$$i_*(K_{bb}) = c = x_2^{-1}x_3^{-1}x_1^{-1} = b^{-1}ab^{-1}a^{-1}a = b^{-1}ab^{-1}, \quad i_*(\mu) = aba^{-1}.$$

The fundamental group  $\pi_1(S^3(K, -1))$  is obtained from  $G$  by introducing a new relation

$$i_*(\mu)^{-1-w} = c^{-1} \stackrel{w=-3}{\iff} ab^2a^{-1} = ba^{-1}b.$$

Hence the fundamental group of  $S^3(K, -1)$  has the presentation

$$\langle a, b \mid aba = bab, ab^2a^{-1} = ba^{-1}b \rangle \iff \langle a, b \mid aba = bab, a^2b^2 = aba^{-1}ba \rangle.$$

Observe that its abelianization is trivial. However, this group is nontrivial. It has order 120 and it can be given the equivalent presentation

$$\langle x, y \mid x^3 = y^5 = (xy)^2 \rangle.$$

It is isomorphic to the binary icosahedral group  $I^*$ . This is the finite subgroup of  $SU(2)$  that projects onto the subgroup  $I \subset SO(3)$  of isometries of a regular icosahedron via the  $2 : 1$  map  $SU(2) \rightarrow SO(3)$ .

The manifold  $S^3(K, -1)$  is called the *Poincaré sphere*, and it is traditionally denoted by  $\Sigma(2, 3, 5)$  because it is diffeomorphic to

$$\{z = (z_0, z_1, z_2) \in \mathbb{C}^3; \quad z_0^2 + z_1^3 + z_2^5 = 0, \quad |z| = \varepsilon\}.$$

It is a  $\mathbb{Z}$ -homology sphere, meaning that its homology is isomorphic to the  $\mathbb{Z}$ -homology of  $S^3$ . □

Suppose that  $X$  is an  $m$ -dimensional smooth manifold with boundary. We want to describe what it means to attach a  $k$ -handle to  $X$ . This operation will produce a new smooth manifold with boundary.

A  $k$ -handle of dimension  $m$  (or a handle of index  $k$ ) is the manifold with corners

$$\mathbf{H}_{k,m} := \mathbb{D}^k \times \mathbb{D}^{m-k}.$$

The disk  $\mathbb{D}^k \times \{0\} \subset \mathbf{H}_{k,m}$  is called the *core*, while the disk  $\{0\} \times \mathbb{D}^{m-k} \subset \mathbf{H}_{k,m}$  is called the *cocore*. The boundary of the handle decomposes as

$$\partial \mathbf{H}_{k,m} = \partial_- \mathbf{H}_{k,m} \cup \partial_+ \mathbf{H}_{k,m},$$

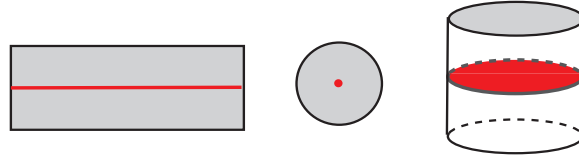

**Fig. 2.4.** A 1-handle of dimension 2, a 0-handle of dimension 2 and a 2-handle of dimension 3. The mid section disks are the cores of these handles.

where

$$\partial_- \mathbf{H}_{k,m} := \partial \mathbb{D}^k \times \mathbb{D}^{m-k}, \quad \partial_+ \mathbf{H}_{k,m} := \mathbb{D}^k \times \partial \mathbb{D}^{k-m}.$$

The operation of attaching a  $k$ -handle (of dimension  $m$ ) requires several additional data.

- A  $(k - 1)$ -dimensional sphere  $\Sigma \hookrightarrow \partial X$  embedded in  $\partial X$  with *trivializable* normal bundle  $T_\Sigma \partial X$ . This normal bundle has rank  $m - k = \dim \partial X - \dim \Sigma$ .
- A framing  $\varphi$  of the normal bundle  $T_\Sigma \partial X$ .

The framing defines a diffeomorphism from  $\mathbb{D}^{m-k} \times S^{k-1}$  to a tubular neighborhood  $N$  of  $\Sigma$  in  $\partial X$ . Using this identification we detect inside  $N$  a copy of  $\partial_- \mathbf{H}_{k,m} = \Sigma \times \mathbb{D}^{m-k}$ . Now attach  $\mathbf{H}_{k,m}$  to  $\partial X$  by identifying  $\partial_- \mathbf{H}_{k,m}$  with its copy inside  $N$  and denote the resulting manifold by  $X^+ = X(\Sigma, \varphi)$ .

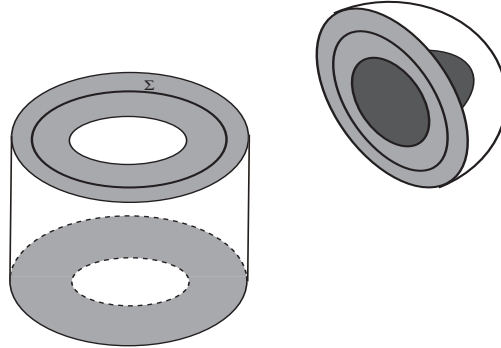
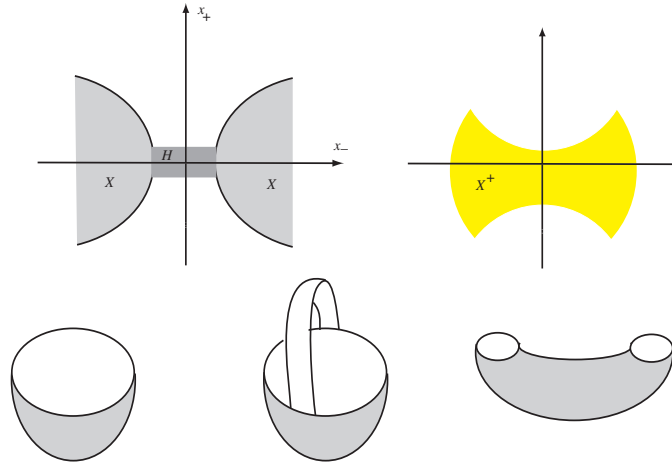

**Fig. 2.5.** Attaching a 2-handle of dimension 3.

The manifold  $X^+$  has corners, but they can be smoothed out (see Figure 2.6). The smoothing procedure is local, so it suffices to understand it in the special case

$$X \cong (-\infty, 0] \times \partial \mathbb{D}^k \times \mathbb{R}^{m-k}, \quad \partial X = \{0\} \times \partial \mathbb{D}^k \times \mathbb{R}^{m-k} (\cong N).$$

Consider the decomposition



**Fig. 2.6.** Attaching a 1-handle of dimension 2 and smoothing the corners.

$$\mathbb{R}^m = \mathbb{R}^k \times \mathbb{R}^{m-k}, \quad \mathbb{R}^m \ni x = (x_-, x_+) \in \mathbb{R}^k \times \mathbb{R}^{m-k}.$$

We have a homeomorphism

$$(-\infty, 0] \times \partial\mathbb{D}^k \times \mathbb{R}^{m-k} \longrightarrow \{x \in \mathbb{R}^m; |x_+|^2 - |x_-|^2 \leq -1\},$$

defined by

$$(-\infty, 0] \times \partial\mathbb{D}^k \times \mathbb{R}^{m-k} \ni (t, \theta, x_+) \mapsto ((e^{-2t} + |x_+|^2)^{1/2} \cdot \theta, x_+) \in \mathbb{R}^k \times \mathbb{R}^{m-k}.$$

The manifold  $X^+$  obtained after the surgery is homeomorphic to

$$\{x \in \mathbb{R}^m; |x_+|^2 - |x_-|^2 \leq 1\},$$

which is a *smooth* manifold with boundary.

This homeomorphism is visible in Figure 2.6, but a formal proof can be read from Figure 2.7.

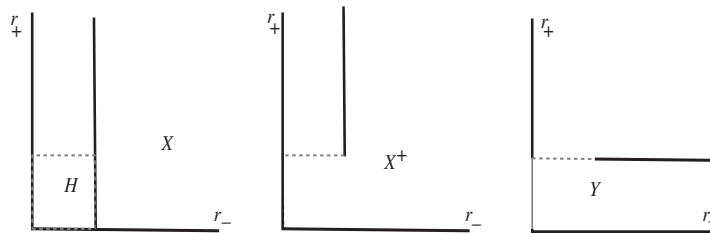

**Fig. 2.7.** Smoothing corners.

Let us explain Figure 2.7. We set  $r_{\pm} = |x_{\pm}|$  and observe that

$$X \cong \{r_- \geq 1\}, \quad \mathbf{H}_{k,m} = \{r_-, r_+ \leq 1\}.$$

After we attach the handle we obtain

$$X_+ = \{r_- \geq 1\} \cup \{r_- \leq 1, r_+ \leq 1\}.$$

Now fix a homeomorphism

$$X_+ \rightarrow Y = \{r_+ \leq 1\},$$

which is the identity in a neighborhood of the region  $\{r_- \cdot r_+ = 0\}$ . Clearly  $Y$  is homeomorphic to the region  $r_+^2 - r_-^2 \leq 1$  via the homeomorphism

$$Y \ni (x_-, x_+) \mapsto (x_-, (1 + r_-^2)^{1/2} x_+).$$

Let us analyze the difference between the topologies of  $\partial X^+$  and  $\partial X$ .

Observe that we have a decomposition

$$\partial X^+ = (\partial X \setminus \partial_- \mathbf{H}_{k,m}) \cup_\varphi \partial_+ \mathbf{H}_{k,m}.$$

Above,  $(\partial X \setminus \partial_- \mathbf{H}_{k,m})$  is a manifold with boundary diffeomorphic to  $\partial \mathbb{D}^{m-k} \times S^{k-1}$  which is identified with the boundary of  $\partial_+ \mathbf{H}_{k,m} = \mathbb{D}^k \times \partial \mathbb{D}^{m-k}$  via the chosen framing  $\varphi$ . In other words,  $\partial X^+$  is obtained from  $\partial X$  via the surgery given by the data  $(S, \varphi)$ .

In general, if  $M_1$  is obtained from  $M_0$  by a surgery of type  $(S, \varphi)$ , then  $M_1$  is cobordant to  $M_0$ . Indeed, consider the manifold

$$X = [0, 1] \times M_0.$$

We obtain an embedding  $S \hookrightarrow \{1\} \times M_0 \hookrightarrow \partial X$  and a framing  $\varphi$  of its normal bundle. Then

$$\partial X(S, \varphi) = M_0(S, \varphi) \sqcup M_0.$$

The above cobordism  $X(S, \varphi)$  is called the *trace* of the surgery.

## 2.2 The Topology of Sublevel Sets

Suppose  $M$  is a smooth connected  $m$ -dimensional manifold and  $f : M \rightarrow \mathbb{R}$  is an *exhaustive* Morse function, i.e., the sublevel set

$$M^c = \{x \in M; f(x) \leq c\}$$

is compact for every  $c \in \mathbb{R}$ . We fix a smooth vector field  $X$  on  $M$  that is *gradient-like* with respect to  $f$ . This means that

$$X \cdot f > 0 \text{ on } M \setminus \mathbf{Cr}_f,$$

and for every critical point  $p$  of  $f$  there exist coordinates adapted to  $p$  and  $X$ , i.e., coordinates  $(x^i)$  such that

$$f = f(p) + \sum_{j=1}^{\lambda} (x^j)^2 - \sum_{k>\lambda} (x^k)^2,$$

$$X = -2 \sum_{i=1}^{\lambda} x^i \partial_{x^i} + 2 \sum_{j>\lambda} x^j \partial_{x^j}, \quad \lambda = \lambda(f, p).$$

In these coordinates near  $p$  the flow  $\Gamma_t$  generated by  $-X$  is described by

$$\Gamma_t(x) = e^{2t} x_- + e^{-2t} x_+,$$

where  $x = x_- + x_+$ ,

$$x_- := (x^1, \dots, x^\lambda, 0, \dots, 0), \quad x_+ := (0, \dots, 0, x^{\lambda+1}, \dots, x^m).$$

To see that there exist such vector fields choose a Riemannian metric  $g$  adapted to  $f$ , i.e., a metric with the property that for every critical point  $p$  of  $f$  there exist coordinates  $(x^i)$  adapted to  $p$  such that near  $p$  we have

$$g = \sum_{i=1}^m (dx^i)^2, \quad f = f(p) + \sum_{j=1}^{\lambda} (x^j)^2 - \sum_{k>\lambda} (x^k)^2.$$

We denote by  $\nabla f = \nabla^g f \in \text{Vect}(M)$  the *gradient* of  $f$  with respect to the metric  $g$ , i.e., the vector field  $g$ -dual to the differential  $df$ . More precisely,  $\nabla f$  is defined by the equality

$$g(\nabla f, X) = df(X) = X \cdot f, \quad \forall X \in \text{Vect}(M).$$

In local coordinates  $(x^i)$ , if

$$df = \sum_i \frac{\partial f}{\partial x^i} dx^i, \quad g = \sum_{i,j} g_{ij} dx^i dx^j,$$

then

$$\nabla f = \sum_j g^{ij} \partial_{x^j} f,$$

where  $(g^{ij})_{1 \leq i, j \leq m}$  denotes the matrix inverse to  $(g_{ij})_{1 \leq i, j \leq m}$ . In particular, near a critical point  $p$  of index  $\lambda$  the gradient of  $f$  in the above coordinates is given by

$$\nabla f = -2 \sum_{i=1}^{\lambda} x^i \partial_{x^i} + 2 \sum_{j>\lambda} x^j \partial_{x^j}.$$

This shows that  $X = \nabla f$  is a gradient-like vector field.

*Remark 2.5.* As explained in [Sm, Theorem B], any gradient-like vector field can be obtained by the method described above.  $\square$

**Notation.** In the sequel, when referring to  $f^{-1}((a, b))$ , we will use the more suggestive notation  $\{a < f < b\}$ . The same goes for  $\{a \leq f < b\}$ , etc.  $\square$

**Theorem 2.6.** *Suppose that the interval  $[a, b] \subset \mathbb{R}$  contains no critical values of  $f$ . Then the sublevel sets  $M^a$  and  $M^b$  are diffeomorphic. Furthermore,  $M^a$  is a deformation retract of  $M^b$ , so that the inclusion  $M^a \hookrightarrow M^b$  is a homotopy equivalence.*

*Proof.* Since there are no critical values of  $f$  in  $[a, b]$  and the sublevel sets  $M^c$  are compact, we deduce that there exists  $\varepsilon > 0$  such that

$$\{a - \varepsilon < f < b + \varepsilon\} \subset M \setminus \mathbf{Cr}_f.$$

Fix a gradient-like vector field  $Y$  and construct a smooth function

$$\rho : M \rightarrow [0, \infty)$$

such that

$$\rho(x) = \begin{cases} |Y \cdot f(x)|^{-1}, & a \leq f(x) \leq b, \\ 0, & f(x) \notin (a - \varepsilon, b + \varepsilon). \end{cases}$$

We can now construct the vector field  $X := -\rho Y$  on  $M$ , and we denote by

$$\Phi : \mathbb{R} \times M \rightarrow M, \quad (t, x) \mapsto \Phi_t(x)$$

the flow generated by  $X$ . If  $u(t)$  is an integral curve of  $X$ , i.e.,  $u(t)$  satisfies the differential equation

$$\dot{u} = X(u).$$

Differentiating  $f$  along  $u(t)$ , we deduce that in the region  $\{a \leq f \leq b\}$  we have the equality

$$\frac{df}{dt} = Xf = -\frac{1}{Yf} Yf = -1.$$

In other words, in the region  $\{a \leq f \leq b\}$  the function  $f$  decreases at a rate of one unit per second. This implies

$$\Phi_{b-a}(M^b) = M^a, \quad \Phi_{a-b}(M^a) = M^b,$$

so that  $\Phi_{b-a}$  establishes a diffeomorphism between  $M^b$  and  $M^a$ .

To show that  $M^a$  is a deformation retract of  $M^b$ , we consider

$$H : [0, 1] \times M^b \rightarrow M^b, \quad H(t, x) = \Phi_{t \cdot (f(x) - a)^+}(x),$$

where for every real number  $r$  we set  $r^+ := \max(r, 0)$ . Observe that if  $f(x) \leq a$ , then



$$H(t, x) = x, \quad \forall t \in [0, 1],$$

while for every  $x \in M^b$  we have

$$H(1, x) = \Phi_{(f(x)-a)^+}(x) \in M^a.$$

This proves that  $M^a$  is a deformation retract of  $M^b$ . □

**Theorem 2.7 (Fundamental structural theorem).** *Suppose  $c$  is a critical value of  $f$  such that the level set  $\{f = c\}$  contains a single critical point  $p$  of Morse index  $\lambda$ . Then, for every  $\varepsilon > 0$  sufficiently small the sublevel set  $\{f \leq c + \varepsilon\}$  is diffeomorphic to  $\{f \leq c - \varepsilon\}$  with a  $\lambda$ -handle of dimension  $m$  attached. If  $x = (x_-, x_+)$  are coordinates adapted to the critical point, then the core of the handle is given by*

$$e_\lambda(p) := \{x_+ = 0, |x_-|^2 \leq \varepsilon\}.$$

*In particular,  $\{f \leq c + \varepsilon\}$  is homotopic to  $\{f \leq c - \varepsilon\}$  with the  $\lambda$ -cell  $e_\lambda$  attached.*

*Proof.* We follow the elegant approach in [M3, Section I.3]. For simplicity we assume  $c = 0$ . There exist  $\varepsilon > 0$  and local coordinates  $(x^i)$  in an open neighborhood  $U$  of  $p$  with the following properties.

- The region  $\{|f| \leq \varepsilon\}$  is compact and contains no critical point of  $f$  in  $U$  other than  $p$ .
- $x^i(p) = 0, \forall i$  and the image of  $U$  under the diffeomorphism

$$(x^1, \dots, x^m) : U \rightarrow \mathbb{R}^m$$

contains the closed disk

$$D = \left\{ \sum (x^i)^2 \leq 2\varepsilon \right\}.$$

•

$$f|_D = - \sum_{i \leq \lambda} (x^i)^2 + \sum_{j > \lambda} (x^j)^2.$$

We set

$$u_- := \sum_{i \leq \lambda} (x^i)^2, \quad u_+ := \sum_{j > \lambda} (x^j)^2.$$

We have

$$f|_D = -u_- + u_+.$$

We fix a smooth function  $\mu : [0, \infty) \rightarrow \mathbb{R}$  with the following properties (see Figure 2.8).

$$\mu(0) > \varepsilon, \quad \mu'(0) = \mu(t) = 0, \quad \forall t \geq 2\varepsilon, \tag{2.5}$$

$$-1 < \mu'(t) \leq 0, \quad \forall t \geq 0. \tag{2.6}$$

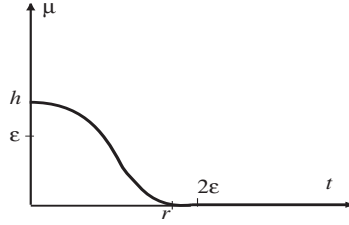

**Fig. 2.8.** The cutoff function  $\mu$ .

Now let (see Figure 2.8)

$$h := \mu(0) > \varepsilon, \quad r := \min\{t; \mu(t) = 0\} \leq 2\varepsilon.$$

Define

$$\Psi : M \rightarrow \mathbb{R}, \quad F(x) = f(x) - \mu(u_-(x) + 2u_+(x)),$$

so that along  $D$  we have

$$\Psi|_D(x) = -u_-(x) + u_+(x) - \mu(u_-(x) + 2u_+(x))$$

while on  $M \setminus D$  we have  $\Psi = f$ .

**Lemma 2.8.** *The function  $\Psi$  satisfies the following properties.*

(a)  $\Psi$  is a Morse function,

$$\mathbf{Cr}_\Psi = \mathbf{Cr}_f, \quad \Psi(p) < -\varepsilon, \quad \text{and} \quad \Psi(q) = f(q), \quad \forall q \in \mathbf{Cr}_f \setminus \{p\}.$$

(b)  $\{f \leq a\} \subset \{\Psi \leq a\}$ ,  $\forall a \in \mathbb{R}$ ,  $\{\Psi \leq \delta\} = \{f \leq \delta\}$ ,  $\forall \delta \geq \varepsilon$ .

*Proof.* (a) Clearly  $\mathbf{Cr}_\Psi \cap (M \setminus D) = \mathbf{Cr}_f \cap (M \setminus U)$ . To show that  $\mathbf{Cr}_\Psi \cap D = \mathbf{Cr}_f \cap D$  we use the fact that along  $D$  we have

$$\Psi = f - \mu(u_- + 2u_+), \quad d\Psi = -(1 + \mu')du_- + (1 - 2\mu')du_+.$$

The condition (2.6) implies that  $du_- = 0 = du_+$  at every critical point  $q$  of  $\Psi$  in  $U$ , so that  $x_-(q) = 0$ ,  $x_+(q) = 0$ , i.e.,  $q = p$ . Clearly  $F(p) = f(p) - \mu(0) < c - \varepsilon$ . Clearly  $p$  is a nondegenerate critical point of  $\Psi$ .

(b) Note first that

$$\Psi \leq f \implies \{f \leq a\} \subset \{\Psi \leq a\}, \quad \forall a \in \mathbb{R}.$$

Again we have

$$\{\Psi \leq \delta\} \cap (M \setminus D) = \{f \leq \delta\} \cap (M \setminus D),$$

so we have to prove

$$\{\Psi \leq \delta\} \cap D \subset \{f \leq \delta\} \cap D.$$

Suppose  $q \in \{\Psi \leq \delta\} \cap D$  and set  $u_{\pm} = u_{\pm}(q)$ . This means that

$$u_- + u_+ \leq 2\varepsilon, \quad u_+ \leq u_- + \delta + \mu(u_- + 2u_+).$$

Using the condition  $-1 < \mu'$  we deduce

$$\mu(t) = \mu(t) - \mu(2\varepsilon) \leq 2\varepsilon - t \leq 2\delta - t, \quad \forall t \leq 2\varepsilon.$$

If  $u_- + 2u_+ \leq 2\varepsilon$ , we have

$$\begin{aligned} u_- + \delta + \mu(u_- + 2u_+) &\leq 3\delta - 2u_+ \Rightarrow u_+ \leq \delta \\ &\Rightarrow u_+ - u_- \leq \delta \Rightarrow f(q) \leq \delta. \end{aligned}$$

If  $u_- + 2u_+ \geq 2\varepsilon$ , then  $f(q) = \Psi(q) \leq \varepsilon$ .  $\square$

The above lemma implies that  $\Psi$  is an exhaustive Morse function such that the interval  $[-\varepsilon, +\varepsilon]$  consists only of regular values. We deduce from Theorem 2.6 that  $\{\Psi \leq \varepsilon\}$  is diffeomorphic to  $\{\Psi \leq -\varepsilon\}$ . Since

$$\{\Psi \leq \varepsilon\} = \{f \leq \varepsilon\},$$

it suffices to show that  $\{\Psi \leq -\varepsilon\}$  is homeomorphic to  $\{f \leq -\varepsilon\}$  with a  $\lambda$ -handle attached.

Denote by  $H$  the closure of

$$\{\Psi \leq -\varepsilon\} \setminus \{f \leq -\varepsilon\} = \{\Psi \leq -\varepsilon\} \cap \{f > -\varepsilon\}.$$

Observe that

$$H = \{\Psi \leq -\varepsilon\} \cap \{f \geq -\varepsilon\} \subset D.$$

The region  $H$  is described by the system of inequalities

$$\begin{cases} u_- + u_+ \leq 2\varepsilon, \\ f = -u_- + u_+ \geq -\varepsilon, & \mu = \mu(u_- + 2u_+). \\ \Psi = -u_- + u_+ - \mu \leq -\varepsilon, \end{cases}$$

Its boundary decomposes as  $\partial H = \partial_- H \cup \partial_+ H$ , where

$$\partial_- H = \begin{cases} u_- + u_+ \leq 2\varepsilon & f = -u_- + u_+ = -\varepsilon, \\ \Psi = -u_- + u_+ - \mu \leq -\varepsilon, \end{cases}$$

and

$$\partial_+ H = \begin{cases} u_- + u_+ \leq 2\varepsilon, \\ f = -u_- + u_+ \geq -\varepsilon, \\ \Psi = -u_- + u_+ - \mu = -\varepsilon. \end{cases}$$

Let us analyze the region  $R$  in the Cartesian plane described by the system of inequalities

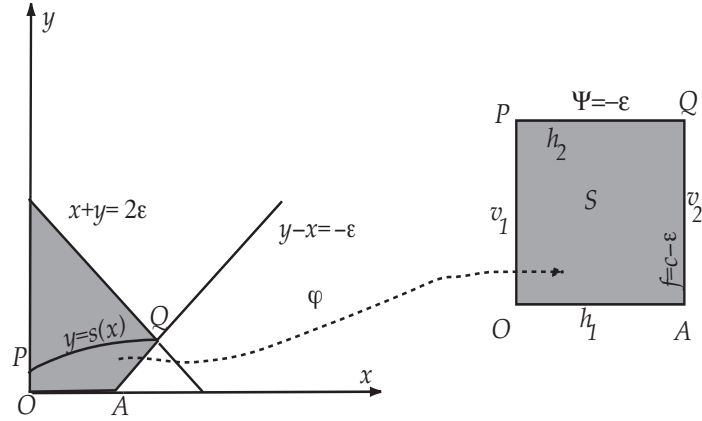

Fig. 2.9. A planar convex region.

$$x, y \geq 0, \quad x + y \leq 2\varepsilon, \quad -x + y - \mu(x + 2y) \leq -\varepsilon, \quad -x + y \geq -\varepsilon.$$

The region

$$\{y - x \geq -\varepsilon, \quad x + y \leq 2\varepsilon, \quad x, y \geq 0\}$$

is the shaded polygonal area depicted in Figure 2.9. The two lines  $y - x = -\varepsilon$  and  $x + y = 2\varepsilon$  intersect at the point  $Q = (\frac{3\varepsilon}{2}, \frac{\varepsilon}{2})$ . We want to investigate the equation

$$-x + y - \mu(x + 2y) + \varepsilon = 0.$$

Set

$$\eta_x(y) := -x + y - \mu(x + 2y) + \varepsilon.$$

Observe that since  $\mu(x) > \mu(0) - x$ , we have

$$\eta_x(0) = -x - \mu(x) + \varepsilon < -\mu(0) + \varepsilon < 0,$$

while

$$\lim_{y \rightarrow \infty} \eta_x(y) = \infty.$$

Since  $y \mapsto \eta_x(y)$  is strictly increasing there exists a unique solution  $y = s(x)$  of the equation  $\eta_x(y) = 0$ . Using the implicit function theorem we deduce that  $s(x)$  depends smoothly on  $x$  and

$$\frac{ds}{dx} = \frac{1 + \mu'}{1 - 2\mu'} \in [0, 1].$$

The point  $Q$  lies on the graph of the function  $y = s(x)$ ,  $s(0) > 0$ , and since  $s'(x) \in [0, 1]$ , we deduce that the slope-1 segment  $AQ$  lies below the graph of  $s(x)$ . We now see that the region  $R$  is described by the system of inequalities

$$x, y \geq 0, \quad y \leq s(x), \quad y - x \geq -\varepsilon.$$

Fix a diffeomorphism  $\varphi$  from  $R$  to the standard square

$$S = \{ (t_-, t_+) \in \mathbb{R}^2; 0 \leq t_{\pm} \leq 1 \}$$

such that the vertices  $O, A, P, Q$  are mapped to the vertices

$$(0, 0), (1, 0), (1, 1), (0, 1)$$

(see Figure 2.9). Denote by  $h_i$  and  $v_j$  the horizontal and vertical edges of  $S$  (see Figure 2.9). Observe that we have a natural projection

$$u : H \rightarrow \mathbb{R}^2, \quad H \ni q \mapsto (x, y) = (u_-(q), u_+(q)).$$

Its image is precisely the region  $R$ , and we denote by  $t = (t_-, t_+)$  the composition  $\varphi \circ u$ . We now have a homeomorphism

$$H \mapsto \mathbf{H}_\lambda = \mathbb{D}^\lambda \times \mathbb{D}^{m-\lambda},$$

$$H \ni q \mapsto (t_-(q)\theta_-(q), t_+(q)\theta_+(q)) \in \mathbb{D}^\lambda \times \mathbb{D}^{m-\lambda},$$

where

$$\theta_{\pm}(q) = u_{\pm}^{-1/2}(q)x_{\pm}(q)$$

denote the angular coordinates on the spheres

$$\Sigma_- := \{ u_- = 1, x_+ = 0 \} \cong S^{\lambda-1}$$

and

$$\Sigma_+ := \{ u_+ = 1, x_- = 0 \} \cong S^{m-\lambda-1}.$$

Then  $\partial_+ H$  corresponds to the part of  $H$  mapped by  $u$  onto  $h_2$ , and  $\partial_- H$  corresponds to the part of  $H$  mapped by  $u$  onto  $v_2$ . The core is the part mapped onto the horizontal segment  $h_1$ , while the co-core is the part of  $H$  mapped onto  $v_1$ . This discussion shows that indeed  $\{ \Psi \leq c - \varepsilon \}$  is obtained from  $\{ f \leq c - \varepsilon \}$  by attaching the  $\lambda$ -handle  $H$ .  $\square$

*Remark 2.9.* Suppose that  $c$  is a critical value of the exhaustive Morse function  $f : M \rightarrow \mathbb{R}$  and the level set  $f^{-1}(c)$  contains critical points  $p_1, \dots, p_k$  with Morse indices  $\lambda_1, \dots, \lambda_k$ . Then the above argument shows that for  $\varepsilon > 0$  sufficiently small the sublevel set  $\{ f \leq c + \varepsilon \}$  is obtained from  $\{ f \leq c - \varepsilon \}$  by attaching handles  $H_1, \dots, H_k$  of indices  $\lambda_1, \dots, \lambda_k$ .  $\square$

**Corollary 2.10.** *Suppose  $M$  is a smooth manifold and  $f : M \rightarrow \mathbb{R}$  is an an exhaustive Morse function on  $M$ . Then  $M$  is homotopy equivalent to a CW-complex that has exactly one  $\lambda$ -cell for every critical point of  $f$  of index  $\lambda$ .  $\square$*

**Example 2.11 (Planar pentagons).** Let us show how to use the fundamental structural theorem in a simple yet very illuminating example. We define a *regular planar pentagon* to be a closed polygonal line in the plane consisting of five straight line segments of equal length 1. We would like to understand the topology of the space of all possible regular planar pentagons.

Consider one such pentagon with vertices  $J_0, J_1, J_2, J_3, J_4$  such that

$$\text{dist}(J_i, J_{i+1}) = 1.$$

There are a few trivial ways of generating new pentagons out of a given one. We can translate it, or we can rotate it about a fixed point in the plane. The new pentagons are not that interesting, and we will declare all pentagons obtained in this fashion from a given one to be equivalent. In other words, we are really interested in orbits of pentagons with respect to the obvious action of the affine isometry group of the plane.

There is a natural way of choosing a representative in such an orbit. We fix a cartesian coordinate system and we assume that the vertex  $J_0$  is placed at the origin, while the vertex  $J_4$  lies on the positive  $x$ -semiaxis, i.e.,  $J_4$  has coordinates  $(1, 0)$ .

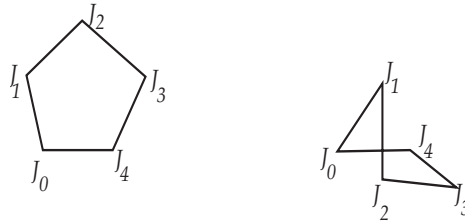

**Fig. 2.10.** Planar pentagons.

Note that we can regard such a pentagon as a robot arm with four segments such that the last vertex  $J_4$  is fixed at the point  $(0, 1)$ . Now recall some of the notation in Example 1.5.

A possible position of such a robot arm is described by four complex numbers,

$$z_1, \dots, z_4, \quad |z_i| = 1, \quad \forall i = 1, 2, 3, 4.$$

Since all the segments of such a robot arm have length 1, the position of the vertex  $J_k$  is given by the complex number  $z_1 + \dots + z_k$ .

The space  $C$  of configurations of the robot arm constrained by the condition that  $J_4$  can only slide along the positive  $x$ -semiaxis is a 3-dimensional manifold. On  $C$  we have a Morse function

$$h : C \rightarrow \mathbb{R}, \quad h(\mathbf{z}) = \mathbf{Re}(z_1 + z_2 + z_3 + z_4),$$

which measures the distance of the last joint to the origin. The space of pentagons can be identified with the level set  $\{h = 1\}$ .

Consider the function  $f = -h : C \rightarrow \mathbb{R}$ . The sublevel sets of  $f$  are compact. Moreover, the computations in Example 1.10 show that  $f$  has exactly five critical points, a local minimum

$$(1, 1, 1, 1),$$

and four critical configurations of index 1

$$(1, 1, 1, -1), (1, 1, -1, 1), (1, -1, 1, 1), (-1, 1, 1, 1),$$

all situated on the level set  $\{h = 2\} = \{f = -2\}$ . The corresponding positions of the robot arm are depicted in Figure 2.11.

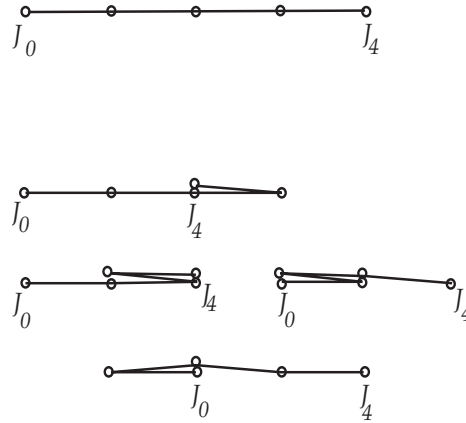

Fig. 2.11. Critical positions.

The level set  $\{f = -1\}$  is not critical, and it is obtained from the sublevel set  $\{f \leq -3\}$  by attaching four 1-handles.

The sublevel set  $\{f \leq -3\}$  is a closed 3-dimensional ball, and thus the sublevel set  $\{f \leq -1\}$  is a 3-ball with four 1-handles attached. Its boundary,  $\{f = -1\}$ , is therefore a Riemann surface of genus 4. We conclude that the space of orbits of regular planar pentagons is a Riemann surface of genus 4. For more general results on the topology of the space of planar polygons we refer to the very nice papers [FaSch, KM]. We will have more to say about this problem in Section 3.1  $\square$

*Remark 2.12.* We can use the fundamental structural theorem to produce a new description of the trace of a surgery. We follow the presentation in [M4, Section 3].

Consider an orthogonal direct sum decomposition  $\mathbb{R}^m = \mathbb{R}^\lambda \oplus \mathbb{R}^{m-\lambda}$ . We denote by  $x$  the coordinates in  $\mathbb{R}^\lambda$  and by  $y$  the coordinates in  $\mathbb{R}^{m-\lambda}$ . Then identify

$$\mathbb{D}^\lambda = \{x \in \mathbb{R}^\lambda; |x| \leq 1\}, \quad \mathbb{D}^{m-\lambda} = \{y \in \mathbb{R}^{m-\lambda}; |y| \leq 1\},$$

$$\mathbf{H}_{\lambda,m} = \{(x,y) \in \mathbb{R}^m; |x|, |y| \leq 1\}.$$

Consider the regions (see Figure 2.12)

$$\hat{B}_\lambda := \{(x,y) \in \mathbb{R}^m; -1 \leq -|x|^2 + |y|^2 \leq 1, \quad 0 \leq |x| \cdot |y| < r\},$$

$$B_\lambda = \{(x,y) \in \hat{B}_\lambda; |x| \cdot |y| > 0\}.$$

The region  $B_\lambda$  has two boundary components (see Figure 2.12)

$$\partial_\pm B_\lambda = \{(x,y) \in B_\lambda; -|x|^2 + |y|^2 = \pm 1\}.$$

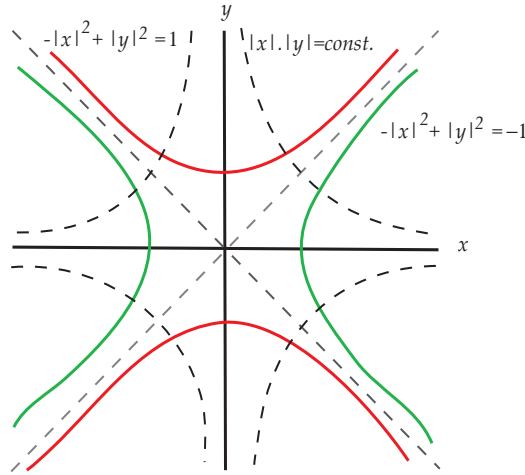

Fig. 2.12. A Morse theoretic picture of the trace of a surgery.

Consider the functions

$$f, h : \mathbb{R}^m \rightarrow \mathbb{R}, \quad f(x,y) = -|x|^2 + |y|^2, \quad h(x,y) = |x| \cdot |y|,$$

so that

$$B_\lambda = \{-1 \leq f \leq 1, \quad 0 < h < r\}, \quad \partial_\pm B_\lambda = \{f = \pm 1, \quad 0 < h < r\}.$$

Denote by  $U$  the gradient vector field of  $f$ . We have

$$U = -U_x + U_y, \quad U_x = 2 \sum_i x^i \partial_{x_i}, \quad U_y = 2 \sum_j y^j \partial_{y_j}.$$



The function  $h$  is differentiable in the region  $h > 0$ , and

$$\nabla h = \frac{|y|}{|x|}x + \frac{|x|}{|y|}y.$$

We deduce

$$U \cdot h = (\nabla h, U) = 0.$$

Define  $V = \frac{1}{U \cdot f}U$  on  $B_\lambda$ . We have

$$V \cdot f = 1, \quad V \cdot h = 0.$$

Denote by  $\Gamma_t$  the flow generated by  $V$ . We have

$$\frac{d}{dt}f(\Gamma_t z) = 1, \quad \forall z \in \mathbb{R}^m \quad \text{and} \quad \frac{d}{dt}h(\Gamma_t z) = 0, \quad \forall z \in \mathbb{R}^m, \quad h(z) > 0.$$

Thus  $h$  is constant along the trajectories of  $V$ , and along such a trajectory  $f$  increases at a rate of one unit per second. We deduce that for any  $z \in \partial_- B_\lambda$  we have

$$f(\Gamma_t z) = -1 + t, \quad h(\Gamma_t z) = h(z) \in (0, 1).$$

We obtain a diffeomorphism

$$\Psi : [-1, 1] \times \partial_- B_\lambda \rightarrow B_\lambda, \quad (t, z) \mapsto \Gamma_{t+1}(z).$$

Its inverse is

$$B_\lambda \ni w \mapsto (f(w), \Gamma_{-1-f(z)}w).$$

This shows that the pullback of  $f : B_\lambda \rightarrow \mathbb{R}$  to  $[-1, 1] \times \partial_- B_\lambda$  via  $\Psi$  coincides with the natural projection

$$[-1, 1] \times \partial_- B_\lambda \rightarrow [-1, 1].$$

Moreover, we have a diffeomorphism

$$\{1\} \times \partial_- B_\lambda \xrightarrow{\Psi} \partial_+ B_\lambda.$$

Now observe that we have a diffeomorphism

$$\begin{aligned} \Phi : (\mathbb{D}^{m-\lambda} \setminus \{0\}) \times S^{\lambda-1} &\rightarrow \partial_- B_\lambda, \\ (\mathbb{D}^{m-\lambda} \setminus \{0\}) \times S^{\lambda-1} \ni (u, v) &\mapsto (\cosh(|u|)v, \sinh(|u|)\theta_u) \in \mathbb{R}^\lambda \times \mathbb{R}^{m-\lambda}, \\ \theta_u &:= \frac{u}{|u|}. \end{aligned}$$

Suppose  $M$  is a smooth manifold of dimension  $m-1$  and we have an embedding

$$\varphi : \mathbb{D}^{m-\lambda} \times S^{\lambda-1} \hookrightarrow M.$$

Consider the manifold  $X = [-1, 1] \times M$  and set

$$X' = X \setminus \varphi\left([-1, 1] \times \{0\} \times S^{\lambda-1}\right).$$

Denote by  $W$  the manifold obtained from the disjoint union  $X' \sqcup \hat{B}_\lambda$  by identifying  $B_\lambda \subset \hat{B}_\lambda$  with an open subset of  $[-1, 1] \times M$  via the gluing map  $\gamma = \varphi \circ \Phi^{-1} \circ \Psi^{-1}$ ,

$$B_\lambda \xrightarrow{\Psi^{-1}} [-1, 1] \times \partial_- B_\lambda \xrightarrow{\Phi^{-1}} [-1, 1] \times (\mathbb{D}^{m-\lambda} \setminus \{0\}) \times S^{\lambda-1} \xrightarrow{\varphi} [-1, 1] \times M.$$

Via the above gluing, the restriction of  $f$  to  $B_\lambda$  is identified with the natural projection  $\pi : X' \rightarrow [-1, 1]$ , i.e.,

$$\gamma^*(f|_{B_\lambda}) = \pi|_{\gamma(B_\lambda)}$$

Gluing  $\pi$  and  $\gamma^*f$  we obtain a smooth function

$$F : W \rightarrow [-1, 1]$$

that has a unique critical point  $p$  with critical value  $F(p) = 0$  and Morse index  $\lambda$ . Set

$$W^a = \{w \in W; F(w) \leq a\}.$$

We deduce from the fundamental structural theorem that  $W^{1/2}$  is obtained from  $W^{-1/2} \cong M$  by attaching a  $\lambda$ -handle with framing given by  $\varphi$ . The region  $\{-\frac{1}{2} \leq F \leq \frac{1}{2}\}$  is therefore diffeomorphic to the trace of the surgery  $M \rightarrow M(S^{\lambda-1}, \varphi)$ .  $\square$

### 2.3 Morse Inequalities

To formulate these important algebraic consequences of the topological facts established so far we need to introduce some terminology.

Denote by  $\mathbb{Z}[[t, t^{-1}]$  the ring of formal Laurent series with integral coefficients. More precisely,

$$\sum_{n \in \mathbb{Z}} a_n t^n \in \mathbb{Z}[[t, t^{-1}]] \iff a_n = 0 \quad \forall n \ll 0, \quad a_m \in \mathbb{Z}, \quad \forall m.$$

Suppose  $\mathbb{F}$  is a field. A graded  $\mathbb{F}$ -vector space

$$A_\bullet = \bigoplus_{n \in \mathbb{Z}} A_n$$

is said to be *admissible* if  $\dim A^n < \infty$ ,  $\forall n$ , and  $A_n = 0$ ,  $\forall n \ll 0$ . To an admissible graded vector space  $A_\bullet$  we associate its *Poincaré series*

$$P_{A_\bullet}(t) := \sum_n (\dim_{\mathbb{F}} A_n) t^n \in \mathbb{Z}[[t, t^{-1}]].$$

We define an order relation  $\succ$  on the ring  $\mathbb{Z}[[t, t^{-1}]]$  by declaring that

$X(t) \succ Y(t) \iff$  there exists  $Q \in \mathbb{Z}[[t, t^{-1}]]$  with *nonnegative coefficients* such that

$$X(t) = Y(t) + (1+t)Q(t). \tag{2.7}$$

*Remark 2.13.* (a) Assume that

$$X(t) = \sum_n x_n t^n \in \mathbb{Z}[[t, t^{-1}]], \quad Y(t) = \sum_n y_n t^n \in \mathbb{Z}[[t, t^{-1}]]$$

are such that  $X \succ Y$ . Then there exists  $Q \in \mathbb{Z}[[t, t^{-1}]]$  such that

$$X(t) = Y(t) + (1+t)Q(t), \quad Q(t) = \sum_n q_n t^n, \quad q_n \geq 0.$$

Then we can rewrite the above equality as

$$(1+t)^{-1}X(t) = (1+t)^{-1}Y(t) + Q(t).$$

Using the identity

$$(1+t)^{-1} = \sum_{n \geq 0} (-1)^n t^n$$

we deduce

$$\sum_{k \geq 0} (-1)^k x_{n-k} - \sum_{k \geq 0} (-1)^k y_{n-k} = q_n \geq 0.$$

Thus the order relation  $\succ$  is equivalent to the *abstract Morse inequalities*

$$X \succ Y \iff \sum_{k \geq 0} (-1)^k x_{n-k} \geq \sum_{k \geq 0} (-1)^k y_{n-k}, \quad \forall n \geq 0. \tag{2.8}$$

Note that (2.7) implies immediately the *weak Morse inequalities*

$$x_n \geq y_n, \quad \forall n \geq 0. \tag{2.9}$$

(b) Observe that  $\succ$  is an order relation satisfying

$$X \succ Y \iff X + R \succ Y + R, \quad \forall R \in \mathbb{Z}[[t, t^{-1}]],$$

$$X \succ Y, \quad Z \succ 0 \implies X \cdot Z \succ Y \cdot Z. \quad \square$$

**Lemma 2.14 (Subadditivity).** *Suppose we have a long exact sequence of admissible graded vector spaces  $A_\bullet, B_\bullet, C_\bullet$ :*

$$\cdots \rightarrow A_k \xrightarrow{i_k} B_k \xrightarrow{j_k} C_k \xrightarrow{\partial_k} A_{k-1} \rightarrow \cdots.$$

Then

$$P_{A_\bullet} + P_{C_\bullet} \succ P_{B_\bullet}. \tag{2.10}$$

*Proof.* Set

$$\begin{aligned} a_k &= \dim A_k, \quad b_k = \dim B_k, \quad c_k = \dim C_k, \\ \alpha_k &= \dim \ker i_k, \quad \beta_k = \dim \ker j_k, \quad \gamma_k = \dim \ker \partial_k. \end{aligned}$$

Then

$$\begin{aligned} &\begin{cases} a_k = \alpha_k + \beta_k \\ b_k = \beta_k + \gamma_k \\ c_k = \gamma_k + \alpha_{k-1} \end{cases} \implies a_k - b_k + c_k = \alpha_k + \alpha_{k-1} \\ &\implies \sum_k (a_k - b_k + c_k)t^k = \sum_k t^k (\alpha_k + \alpha_{k-1}) \\ &\implies P_{A_\bullet}(t) - P_{B_\bullet}(t) + P_{C_\bullet}(t) = (1+t)Q(t), \quad Q(t) = \sum_k \alpha_k t^k. \end{aligned}$$

□

For every compact topological space  $X$  we denote by  $b_k(X) = b_k(X, \mathbb{F})$  the  $k$ th *Betti number* (with coefficients in  $\mathbb{F}$ )

$$b_k(X) := \dim H_k(X, \mathbb{F}),$$

and by  $P_X(t) = P_{X, \mathbb{F}}(t)$  the Poincaré polynomial

$$P_{X, \mathbb{F}}(t) = \sum_k b_k(X, \mathbb{F})t^k.$$

If  $Y$  is a subspace of  $X$  then the relative Poincaré polynomial  $P_{X,Y}(t)$  is defined in a similar fashion. The *Euler characteristic* of  $X$  is

$$\chi(X) = \sum_{k \geq 0} (-1)^k b_k(X),$$

and we have the equality

$$\chi(X) = P_X(-1).$$

**Corollary 2.15 (Topological Morse inequalities).** *Suppose  $f : M \rightarrow \mathbb{R}$  is a Morse function on a smooth compact manifold of dimension  $M$  with Morse polynomial*

$$P_f(t) = \sum_\lambda \mu_f(\lambda)t^\lambda.$$

*Then for every field of coefficients  $\mathbb{F}$  we have*

$$P_f(t) \succ P_{M, \mathbb{F}}(t).$$

*In particular,*

$$\sum_{\lambda \geq 0} (-1)^\lambda \mu_f(\lambda) = P_f(-1) = P_{M, \mathbb{F}}(-1) = \chi(M).$$

*Proof.* Let  $c_1 < c_1 < \dots < c_\nu$  be the critical values of  $f$ . Set (see Figure 2.13)

$$t_0 = c_1 - 1, t_\nu = c_\nu + 1, \quad t_k = \frac{c_k + c_{k+1}}{2}, \quad k = 1, \dots, \nu - 1,$$

$$M_i = \{f \leq t_i\}, \quad 0 \leq i \leq \nu.$$

For simplicity, we drop the field of coefficients from our notations.

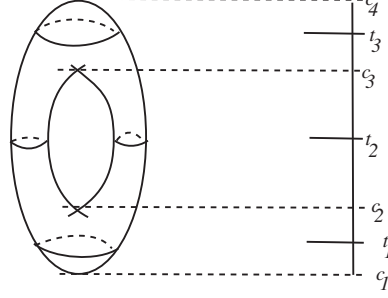

**Fig. 2.13.** Slicing a manifold by a Morse function.

From the long exact homological sequence of the pair  $(M_i, M_{i-1})$  and the subadditivity lemma we deduce

$$P_{M_{i-1}} + P_{M_i, M_{i-1}} \succcurlyeq P_{M_i}.$$

Summing over  $i = 1, \dots, \nu$ , we deduce

$$\sum_{i=1}^{\nu} P_{M_{i-1}} + \sum_{i=1}^{\nu} P_{M_i, M_{i-1}} \succcurlyeq \sum_{i=1}^{\nu} P_{M_i} \implies \sum_{k=1}^{\nu} P_{M^k, M^{k-1}} \succcurlyeq P_{M^\nu}.$$

Using the equality  $M_\nu = M$  we deduce

$$\sum_{i=1}^{\nu} P_{M_i, M_{i-1}} \succcurlyeq P_M.$$

Denote by  $\mathbf{Cr}_i \subset \mathbf{Cr}_f$  the critical points on the level set  $\{f = c_i\}$ . From the fundamental structural theorem and the excision property of the singular homology we deduce

$$H_\bullet(M_i, M_{i-1}; \mathbb{F}) \cong \bigoplus_{p \in \mathbf{Cr}_i} H_\bullet(\mathbf{H}_{\lambda(p)}, \partial_- \mathbf{H}_{\lambda(p)}; \mathbb{F}) \cong \bigoplus_{p \in \mathbf{Cr}_i} H_\bullet(e_{\lambda(p)}, \partial e_{\lambda(p)}; \mathbb{F}).$$

Now observe that  $H_k(e_\lambda, \partial e_\lambda; \mathbb{F}) = 0, \forall k \neq \lambda$ , while  $H_\lambda(e_\lambda, \partial e_\lambda; \mathbb{F}) \cong \mathbb{F}$ . Hence

$$P_{M_i, M_{i-1}}(t) = \sum_{p \in \mathbf{Cr}_i} t^{\lambda(p)}.$$

Hence

$$P_f(t) = \sum_{i=1}^{\nu} P_{M_i, M_{i-1}}(t) \succ P_M. \quad \square$$

*Remark 2.16.* The above proof yields the following more general result. If

$$X_1 \subset \dots \subset X_\nu = X$$

is an increasing filtration by closed subsets of the compact space  $X$ , then

$$\sum_{i=1}^{\nu} P_{X_i, X_{i-1}}(t) \succ P_X(t). \quad \square$$

Suppose  $\mathbb{F}$  is a field and  $f$  is a Morse function on a compact manifold. We say that a critical point  $p \in \mathbf{Cr}_f$  of index  $\lambda$  is  $\mathbb{F}$ -*completable* if the boundary of the core  $e_\lambda(p)$  defines a trivial homology class in  $H_{\lambda-1}(M^{c-\varepsilon}, \mathbb{F})$ ,  $c = f(p)$ ,  $0 < \varepsilon \ll 1$ . We say that  $f$  is  $\mathbb{F}$ -*completable* if all its critical points are  $\mathbb{F}$ -completable.

We say that  $f$  is an  $\mathbb{F}$ -*perfect* Morse function if its Morse polynomial is equal to the Poincaré polynomial of  $M$  with coefficients in  $\mathbb{F}$ , i.e., all the Morse inequalities become equalities.

**Proposition 2.17.** *Any  $\mathbb{F}$ -completable Morse function on a smooth, closed, compact manifold is  $\mathbb{F}$ -perfect.*

*Proof.* Suppose  $f : M \rightarrow \mathbb{R}$  is a Morse function on the compact, smooth  $m$ -dimensional manifold. Denote by  $c_1 < \dots < c_\nu$  the critical values of  $M$  and set (see Figure 2.13)

$$t_0 = c_1 - 1, t_\nu = c_\nu + 1, \quad t_i := \frac{c_i + c_{i+1}}{2}, \quad i = 1, \dots, \nu - 1.$$

Denote by  $\mathbf{Cr}_i \subset \mathbf{Cr}_f$  the critical points on the level set  $\{f = c_i\}$ . Set  $M_i := \{f \leq t_i\}$ . From the fundamental structural theorem and the excision property of the singular homology we deduce

$$H_\bullet(M_i, M_{i-1}; \mathbb{F}) \cong \bigoplus_{p \in \mathbf{Cr}_i} H_\bullet(\mathbf{H}_{\lambda(p)}, \partial_- \mathbf{H}_{\lambda(p)}; \mathbb{F}) \cong \bigoplus_{p \in \mathbf{Cr}_i} H_\bullet(e_{\lambda(p)}, \partial e_{\lambda(p)}; \mathbb{F}).$$

Now observe that  $H_k(e_\lambda, \partial e_\lambda; \mathbb{F}) = 0$ ,  $\forall k \neq \lambda$ , while  $H_\lambda(e_\lambda, \partial e_\lambda; \mathbb{F}) \cong \mathbb{F}$ . This last isomorphism is specified by fixing an orientation on  $e_\lambda(p)$ , which then produces a basis of  $H_\lambda(H_\lambda, \partial_- H_\lambda; \mathbb{F})$  described by the relative homology class  $[e_\lambda, \partial e_\lambda]$ .

The connecting morphism

$$H_\bullet(M_i, M_{i-1}; \mathbb{F}) \xrightarrow{\partial} H_{\bullet-1}(M_{i-1}, \mathbb{F})$$

maps  $[e_\lambda, \partial e_{\lambda(p)}]$  to the image of  $[\partial e_\lambda]$  in  $H_{\lambda(p)-1}(M_{i-1}, \mathbb{F})$ . Since  $f$  is  $\mathbb{F}$ -completable we deduce that these connecting morphisms are trivial. Hence for every  $1 \leq i \leq \nu$  we have a short exact sequence

$$0 \rightarrow H_\bullet(M_{i-1}, \mathbb{F}) \rightarrow H_\bullet(M_i, \mathbb{F}) \rightarrow \bigoplus_{p \in \mathbf{Cr}_i} H_\bullet(e_{\lambda(p)}, \partial e_{\lambda(p)}; \mathbb{F}) \rightarrow 0.$$

Hence

$$P_{M_i, \mathbb{F}}(t) = P_{M_{i-1}, \mathbb{F}}(t) + \sum_{p \in \mathbf{Cr}_i} t^{\lambda(p)}.$$

Summing over  $i = 1, \dots, \nu$  and observing that  $M_0 = \emptyset$  and  $M_\nu = M$ , we deduce

$$P_{M, \mathbb{F}}(t) = \sum_{i=1}^{\nu} \sum_{p \in \mathbf{Cr}_i} t^{\lambda(p)} = P_f(t). \quad \square$$

Let us describe a simple method of recognizing completable functions.

**Proposition 2.18.** *Suppose  $f : M \rightarrow \mathbb{R}$  is a Morse function on a compact manifold satisfying the gap condition*

$$|\lambda(p) - \lambda(q)| \neq 1, \quad \forall p, q \in \mathbf{Cr}_f.$$

*Then  $f$  is  $\mathbb{F}$ -completable for any field  $\mathbb{F}$ .*

*Proof.* We continue to use the notation in the proof of Proposition 2.17. Set

$$A := \{ \lambda(p); p \in \mathbf{Cr}_f \}, \quad \Lambda_i = \{ \lambda(p); p \in \mathbf{Cr}_i \} \subset \mathbb{Z}.$$

The gap condition shows that

$$\lambda \in \Lambda \implies \lambda \pm 1 \in \mathbb{Z} \setminus \Lambda. \quad (2.11)$$

Note that the fundamental structural theorem implies

$$H_k(M_i, M_{i-1}; \mathbb{F}) = 0 \iff k \in \mathbb{Z} \setminus \Lambda, \quad (2.12)$$

since  $M_i/M_{i-1}$  is homotopic to a wedge of spheres of dimensions belonging to  $\Lambda$ .

We will prove by induction over  $i \geq 0$  that

$$k \in \mathbb{Z} \setminus \Lambda \implies H_k(M_i, \mathbb{F}) = 0, \quad (A_i)$$

and that the connecting morphism

$$\partial : H_k(M_i, M_{i-1}; \mathbb{F}) \longrightarrow H_{k-1}(M_{i-1}, \mathbb{F}) \quad (B_i)$$

is trivial for every  $k \geq 0$ .

The above assertions are trivially true for  $i = 0$ . Assume  $i > 0$ . We begin by proving  $(B_i)$ .

This statement is obviously true if  $H_k(M_i, M_{i-1}; \mathbb{F}) = 0$ , so we may assume  $H_k(M_i, M_{i-1}; \mathbb{F}) \neq 0$ . Note that (2.12) implies  $k \in \Lambda$ , and thus the gap condition (2.11) implies that  $k - 1 \in \mathbb{Z} \setminus \Lambda$ .

The inductive assumption  $(A_{i-1})$  implies that  $H_{k-1}(M_{i-1}, \mathbb{F}) = 0$ , so that the connecting morphism

$$\partial : H_k(M_i, M_{i-1}; \mathbb{F}) \rightarrow H_{k-1}(M_{i-1}, \mathbb{F})$$

is zero. This proves  $(B_i)$ . In particular, for every  $k \geq 0$  we have an exact sequence

$$0 \rightarrow H_k(M_{i-1}, \mathbb{F}) \rightarrow H_k(M_i, \mathbb{F}) \rightarrow H_k(M_i, M_{i-1}; \mathbb{F}).$$

Suppose  $k \in \mathbb{Z} \setminus \Lambda$ . Then  $H_k(M_i, M_{i-1}; \mathbb{F}) = 0$ , so that  $H_k(M_i, \mathbb{F}) \cong H_k(M_{i-1}, \mathbb{F})$ . From  $(A_{i-1})$  we now deduce  $H_k(M_{i-1}, \mathbb{F}) = 0$ . This proves  $(A_i)$  as well.

To conclude the proof of the proposition observe that  $(B_i)$  implies that  $f$  is  $\mathbb{F}$ -completable.  $\square$

**Corollary 2.19.** *Suppose  $f : M \rightarrow \mathbb{R}$  is a Morse function on a compact manifold whose critical points have only even indices. Then  $f$  is a perfect Morse function.*  $\square$

**Example 2.20.** Consider the round sphere

$$S^n = \{ (x^0, \dots, x^n) \in \mathbb{R}^{n+1}; \sum_i |x^i|^2 = 1 \}.$$

The height function

$$h_n : S^n \rightarrow \mathbb{R}, \quad (x^0, \dots, x^n) \mapsto x^0$$

is a Morse function with two critical points: a global maximum at the north pole  $x^0 = 1$  and a global minimum at the south pole,  $x^0 = -1$ .

For  $n > 1$  this is a perfect Morse function, and we deduce

$$P_{S^n}(t) = P_{h_n}(t) = 1 + t^n.$$

Consider the manifold  $M = S^m \times S^n$ . For  $|n - m| \geq 2$  the function

$$h_{m,n} : S^m \times S^n \rightarrow \mathbb{R}, \quad S^m \times S^n \ni (x, y) \mapsto h_m(x) + h_n(y),$$

is a Morse function with Morse polynomial

$$P_{h_{m,n}}(t) = P_{h_m}(t)P_{h_n}(t) = 1 + t^m + t^n + t^{m+n},$$

and since  $|n - m| \geq 2$ , we deduce that it is a perfect Morse function.  $\square$



**Example 2.21.** Consider the complex projective space  $\mathbb{C}\mathbb{P}^n$  with projective coordinates  $[z_0, \dots, z_n]$  and define

$$f : \mathbb{C}\mathbb{P}^n \rightarrow \mathbb{R}, \quad f([z_0, z_1, \dots, z_n]) = \frac{\sum_{j=1}^n j|z_j|^2}{|z_0|^2 + \dots + |z_n|^2}.$$

We want to prove that  $f$  is a perfect Morse function.

The projective space  $\mathbb{C}\mathbb{P}^n$  is covered by the coordinate charts

$$V_k = \{z_k \neq 0\}, \quad k = 0, 1, \dots, n,$$

with affine complex coordinates

$$v^i = v^i(k) = \frac{z_i}{z_k}, \quad i \in \{0, 1, \dots, n\} \setminus \{k\}.$$

Fix  $k$  and set

$$|v|^2 := |v(k)|^2 = \sum_{i \neq k} |v^i|^2.$$

Then

$$f|_{V_k} = \underbrace{\left(k + \sum_{j \neq k} j|v^j|^2\right)}_{=: k+a(v)} \underbrace{(1 + |v|^2)^{-1}}_{=: b(v)}.$$

Observe that  $db = -b^2 d|v|^2$  and

$$\begin{aligned} df|_{V_k} &= bda - (k+a)b^2 d|v|^2 = b^2 \sum_{j \neq k} (j(1 + |v|^2) - (k+a)) d|v^j|^2 \\ &= b^2 \sum_{j \neq k} ((j-k) + (|v|^2 - a)) d|v^j|^2. \end{aligned}$$

Since

$$d|v^j|^2 = \bar{v}^j dv^j + v^j d\bar{v}^j,$$

and the collection  $\{dv^j, d\bar{v}^j; j \neq k\}$  defines a trivialization of  $T^*V_k \otimes \mathbb{C}$  we deduce that  $v$  is a critical point of  $f|_{V_k}$  if and only if

$$(j(1 + |v|^2) - (k+a))v^j = 0, \quad \forall j \neq k.$$

Hence  $f|_{V_k}$  has only one critical point  $p_k$  with coordinates  $v(k) = 0$ . Near this point we have the Taylor expansions

$$\begin{aligned} (1 + |v|^2)^{-1} &= 1 - |v|^2 + \dots, \\ f|_{V_k} &= (k+a(v))(1 - |v|^2 + \dots) = k + \sum_{j \neq k} (j-k)|v^j|^2 + \dots \end{aligned}$$

This shows that Hessian of  $f$  at  $p_k$  is

$$H_{f,p_k} = 2 \sum_{j \neq k} (j - k)(x_j^2 + y_j^2), \quad v^j = x_j + y_j \mathbf{i}.$$

Hence  $p_k$  is nondegenerate and has index  $\lambda(p_k) := 2k$ . This shows that  $f$  is a  $\mathbb{Q}$ -perfect Morse function with Morse polynomial

$$P_{\mathbb{C}\mathbb{P}^n}(t) = P_f(t) = \sum_{j=0}^n t^{2j} = \frac{1 - t^{2(n+1)}}{1 - t^2}.$$

Let us point out an interesting fact which suggests some of the limitations of the homological techniques we have described in this section.

Consider the perfect Morse function  $h_{2,4} : S^2 \times S^4 \rightarrow \mathbb{R}$  described in Example 2.20. Its Morse polynomial is

$$P_{2,4} = 1 + t^2 + t^4 + t^6$$

and thus coincides with the Morse polynomial of the perfect Morse function  $f : \mathbb{C}\mathbb{P}^3 \rightarrow \mathbb{R}$  investigated in this example. However  $S^2 \times S^4$  is not even homotopic to  $\mathbb{C}\mathbb{P}^3$ , because the cohomology ring of  $S^2 \times S^4$  is not isomorphic to the cohomology ring of  $\mathbb{C}\mathbb{P}^3$ .  $\square$

*Remark 2.22.* The above example may give the reader the impression that on any smooth compact manifold there should exist perfect Morse functions. This is not the case. In Exercise 6.20 we describe a class of manifolds which do not admit perfect Morse functions. The Poincaré sphere is one such example.  $\square$

## 2.4 Morse–Smale Dynamics

Suppose  $f : M \rightarrow \mathbb{R}$  is a Morse function on the compact manifold  $M$  and  $\xi$  is a gradient-like vector field relative to  $f$ . We denote by  $\Phi_t$  the flow on  $M$  determined by  $-\xi$ . We will refer to it as the *descending flow* determined by the gradient like vector field  $\xi$ .

**Lemma 2.23.** *For every  $p_0 \in M$  the limits*

$$\Phi_{\pm\infty}(p_0) := \lim_{t \rightarrow \pm\infty} \Phi_t(p_0)$$

*exist and are critical points of  $f$ .*  $\square$

*Proof.* Set  $\gamma(t) := \Phi_t(p_0)$ . If  $\gamma(t)$  is the constant path, then the statement is obvious. Assume that  $\gamma(t)$  is not constant.

Since  $\xi \cdot f \geq 0$  and  $\dot{\gamma}(t) = -\xi(\gamma(t))$ , we deduce that

$$\dot{f} := \frac{d}{dt}f(\gamma(t)) = df(\dot{\gamma}) = -\xi \cdot f \leq 0.$$

From the condition  $\xi \cdot f > 0$  on  $M \setminus \mathbf{Cr}_f$  and the assumption that  $\gamma(t)$  is not constant we deduce

$$\dot{f}(t) < 0, \quad \forall t.$$

Define  $\Omega_{\pm\infty}$  to be the set of points  $q \in M$  such that there exists a sequence  $t_n \rightarrow \pm\infty$  with the property that

$$\lim_{n \rightarrow \infty} \gamma(t_n) = q.$$

Since  $M$  is compact we deduce  $\Omega_{\pm\infty} \neq \emptyset$ . We want to prove that  $\Omega_{\pm\infty}$  consist of a single point which is a critical point of  $f$ . We discuss only  $\Omega_\infty$ , since the other case is completely similar.

Observe first that

$$\Phi_t(\Omega_\infty) \subset \Omega_\infty, \quad \forall t \geq 0.$$

Indeed, if  $q \in \Omega_\infty$  and  $\gamma(t_n) \rightarrow q$ , then

$$\gamma(t_n + t) = \Phi_t(\gamma(t_n)) \rightarrow \Phi_t(q) \in \Omega_\infty.$$

Suppose  $q_0, q_1$  are two points in  $\Omega_\infty$ . Then there exists an increasing sequence  $t_n \rightarrow \infty$  such that

$$\gamma(t_{2n+i}) \rightarrow q_i, \quad i = 0, 1, \quad t_{2n+1} \in (t_{2n}, t_{2n+2}).$$

We deduce

$$f(\gamma(t_{2n})) > f(\gamma(t_{2n+1})) > f(\gamma(t_{2n+2})).$$

Letting  $n \rightarrow \infty$  we deduce  $f(q_0) = f(q_1)$ ,  $\forall q_0, q_1 \in \Omega_\infty$ , so that there exists  $c \in \mathbb{R}$  such that

$$\Omega_\infty \subset f^{-1}(c).$$

If  $q \in \Omega_\infty \setminus \mathbf{Cr}_f$ , then  $t \mapsto \Phi_t(q) \in \Omega_\infty$  is a nonconstant trajectory of  $-\xi$  contained in a level set  $f^{-1}(c)$ . This is impossible since  $f$  decreases strictly on such nonconstant trajectories. Hence

$$\Omega_\infty \subset \mathbf{Cr}_f.$$

To conclude it suffices to show that  $\Omega_\infty$  is connected. Denote by  $\mathcal{C}$  the set of connected components of  $\Omega_\infty$ . Assume that  $\#\mathcal{C} > 1$ . Fix a metric  $d$  on  $M$  and set

$$\delta := \min\{ \text{dist}(C, C'); C, C' \in \mathcal{C}, C \neq C' \} > 0.$$

Let  $C_0 \neq C_1 \in \mathcal{C}$  and  $q_i \in C_i$ ,  $i = 0, 1$ . Then there exists an increasing sequence  $t_n \rightarrow \infty$  such that

$$\gamma(t_{2n+i}) \rightarrow q_i, \quad i = 0, 1, \quad t_{2n+1} \in (t_{2n}, t_{2n+2}).$$

Observe that

$$\begin{aligned}\lim \operatorname{dist}(\gamma(t_{2n}), C_0) &= \operatorname{dist}(q_0, C_0) = 0, \\ \lim \operatorname{dist}(\gamma(t_{2n+1}), C_0) &= \operatorname{dist}(q_1, C_0) \geq \delta.\end{aligned}$$

From the intermediate value theorem we deduce that for all  $n \gg 0$  there exists  $s_n \in (t_{2n}, t_{2n+1})$  such that

$$\operatorname{dist}(\gamma(s_n), C_0) = \frac{\delta}{2}.$$

A subsequence of  $\gamma(s_n)$  converges to a point  $q \in \Omega_\infty$  such that  $\operatorname{dist}(q, C_0) = \frac{\delta}{2}$ . This is impossible since  $q \in \Omega_\infty \subset \mathbf{Cr}_f \setminus C_0$ . This concludes the proof of Lemma 2.23.  $\square$

Suppose  $f : M \rightarrow \mathbb{R}$  is a Morse function and  $p_0 \in \mathbf{Cr}_f$ ,  $c_0 = f(p_0)$ . Fix a gradient-like vector field  $\xi$  on  $M$  and denote by  $\Phi_t$  the flow on  $M$  generated by  $-\xi$ . We set

$$W_{p_0}^\pm = W_{p_0}^\pm(\xi) := \Phi_{\pm\infty}^{-1}(p_0) = \{x \in M; \lim_{t \rightarrow \pm\infty} \Phi_t(x) = p_0\}.$$

$W_{p_0}^\pm(\xi)$  is called the *stable/unstable manifold* of  $p_0$  (relative to the gradient-like vector field  $\xi$ ). We set

$$S_{p_0}^\pm(\varepsilon) = W_{p_0}^\pm \cap \{f = c_0 \pm \varepsilon\}.$$

**Proposition 2.24.** *Let  $m = \dim M$ ,  $\lambda = \lambda(f, p_0)$ . Then  $W_{p_0}^-$  is a smooth manifold homeomorphic to  $\mathbb{R}^\lambda$ , while  $W_{p_0}^+$  is a smooth manifold homeomorphic to  $\mathbb{R}^{m-\lambda}$ .*

*Proof.* We will only prove the statement for the unstable manifold since  $-\xi$  is a gradient-like vector field for  $-f$  and  $W_{p_0}^+(\xi) = W_{p_0}^-(-\xi)$ . We will need the following auxiliary result.

**Lemma 2.25.** *For any sufficiently small  $\varepsilon > 0$  the set  $S_{p_0}^-(\varepsilon)$  is a sphere of dimension  $\lambda - 1$  smoothly embedded in the level set  $\{f = c_0 - \varepsilon\}$  with trivializable normal bundle.*

*Proof.* Pick local coordinates  $x = (x_-, x_+)$  adapted to  $p_0$ . Fix  $\varepsilon > 0$  sufficiently small so that in the neighborhood

$$U = \{|x_-|^2 + |x_+|^2 < r\}$$

the vector field  $\xi$  has the form

$$-2x_- \partial_{x_-} + x_+ \partial_{x_+} = -2 \sum_{i \leq \lambda} x^i \partial_{x^i} + 2 \sum_{j > \lambda} x^j \partial_{x^j}.$$

A trajectory  $\Phi_t(q)$  of  $-\xi$  which converges to  $p_0$  as  $t \rightarrow -\infty$  must stay inside  $U$  for all  $t \ll 0$ . Inside  $U$ , the only such trajectories have the form  $e^{2t}x_-$ , and they are all included in the disk

$$\mathbb{D}_{p_0}^-(r) = \{x_+ = 0, |x_-|^2 \leq r\}.$$

Moreover, since  $f$  decreases strictly on nonconstant trajectories, we deduce that if  $\varepsilon < r$ , then

$$S_{p_0}^-(\varepsilon) = \partial\mathbb{D}_{p_0}^-(\varepsilon). \quad \square$$

Fix now a diffeomorphism  $u : S^{\lambda-1} \rightarrow S_{p_0}^-(\varepsilon)$ . If  $(r, \theta)$ ,  $\theta \in S^{\lambda-1}$ , denote the polar coordinates on  $\mathbb{R}^\lambda$ , we can define

$$F : \mathbb{R}^\lambda \rightarrow W_{p_0}^-, \quad F(r, \theta) = \Phi_{\frac{1}{2} \log r}(u(\theta)).$$

The arguments in the proof of Lemma 2.25 show that  $F$  is a diffeomorphism.  $\square$

*Remark 2.26.* The stable and unstable manifolds of a critical point are not closed subsets of  $M$ . In fact, their closures tend to be quite singular, and one can say that the topological complexity of  $M$  is hidden in the structure of these singularities.  $\square$

We have the following fundamental result of S. Smale [Sm].

**Theorem 2.27.** *Suppose  $f : M \rightarrow \mathbb{R}$  is a Morse function on a compact manifold. Then there exists a gradient-like vector field  $\xi$  such that for any  $p_0, p_1 \in \mathbf{Cr}_f$  the unstable manifold  $W_{p_0}^-(\xi)$  intersects the stable manifold  $W_{p_1}^+(\xi)$  transversally.*

*Proof.* For the sake of clarity we prove the theorem only in the special case when  $f$  is nonresonant, i.e., every level set of  $f$  contains at most one critical point. The general case is only notationally more complicated. Let

$$\Delta_f = \{c_1 < \cdots < c_\nu\}$$

be the set of critical values of  $f$ . Denote by  $p_i$  the critical point of  $f$  on the level set  $\{f = c_i\}$ . Clearly  $W_{p_i}^-$  intersects  $W_{p_j}^+$  transversally at  $p$ ,  $\forall p \in \mathbf{Cr}_f$ .

In general,  $W_{p_i}^+ \cap W_{p_j}^-$  is a union of trajectories of  $-\xi$  and

$$W_{p_i}^+ \cap W_{p_j}^- \neq \emptyset \implies f(p_i) \leq f(p_j) \iff i \leq j.$$

Note that if  $r$  is a regular value of  $f$ , then the manifolds  $W_p^\pm(\xi)$  intersect the level set  $\{f = r\}$  transversally, since  $\xi$  is transversal to the level set and tangent to  $W^\pm$ . For every regular value  $r$  we set

$$W_{p_i}^\pm(\xi)_r := W_{p_i}^\pm(\xi) \cap \{f = r\}.$$

Observe that

$$W_{p_j}^-(\xi) \cap W_{p_i}^+(\xi) \iff W_{p_j}^-(\xi)_r \cap W_{p_i}^+(\xi)_r,$$

for some regular value  $f(p_i) < r < f(p_j)$ .

For any real numbers  $a < b$  such that the interval  $[a, b]$  contains only regular values and any gradient-like vector field  $\xi$  we have a diffeomorphism

$$\Phi_{b,a}^\xi : \{f = a\} \longrightarrow \{f = b\}$$

obtained by following the trajectories of the flow of the vector field

$$\langle \xi \rangle := \frac{1}{\xi \cdot f} \xi \quad (2.13)$$

along which  $f$  increases at a rate of one unit per second. We denote by  $\Phi_{a,b}^\xi$  its inverse. Note that

$$W_{p_i}^\pm(\xi)_a = \Phi_{a,b}^\xi(W_{p_i}^\pm(\xi)_b), \quad W_{p_i}^\pm(\xi)_b = \Phi_{b,a}^\xi(W_{p_i}^\pm(\xi)_a).$$

For every  $r \in \mathbb{R}$  we set  $M_r := \{f = r\}$ .

**Lemma 2.28 (The main deformation lemma).** *Suppose  $a < b$  are such that  $[a, b]$  consists only of regular values of  $f$ . Suppose  $h : M_b \rightarrow M_b$  is a diffeomorphism of  $M_b$  isotopic to the identity. This means that there exists a smooth map*

$$H : [0, 1] \times M_b \rightarrow M_b, \quad (t, x) \mapsto h_t(x),$$

*such that  $x \mapsto h_t(x)$  is a diffeomorphism of  $M_b$ ,  $\forall t \in [0, 1]$ ,  $h_0 = \mathbb{1}_{M_b}$ ,  $h_1 = h$ . Then there exists a gradient-like vector field  $\eta$  for  $f$  which coincides with  $\xi$  outside  $\{a < f < b\}$  and such that the diagram below is commutative:*

$$\begin{array}{ccc} M_b & \xrightarrow{h} & M_b \\ & \searrow \Phi_{b,a}^\xi & \nearrow \Phi_{b,a}^\eta \\ & M_a & \end{array}$$

*Proof.* For the simplicity of exposition we assume that  $a = 0$ ,  $b = 1$  and that the correspondence  $t \mapsto h_t$  is independent of  $t$  for  $t$  close to 0 and 1. Note that we have a diffeomorphism

$$\Psi : [0, 1] \times M_1 \rightarrow \{0 \leq f \leq 1\}, \quad (t, x) \mapsto \Phi_{t,1}^\xi(x) \in \{f = t\}.$$

Its inverse is

$$y \mapsto (f(y), \Phi_{1,f(y)}^\xi(y)).$$

Using the isotopy  $H$  we obtain a diffeomorphism

$$\hat{H} := [0, 1] \times M_1 \rightarrow [0, 1] \times M_1, \quad \hat{H}(t, x) = (t, h_t(x)).$$

It is now clear that the pushforward of the vector field  $\langle \xi \rangle$  in (2.13) via the diffeomorphism

$$F = \Psi \circ \hat{H} \circ \Psi^{-1} : \{0 \leq f \leq 1\} \rightarrow \{0 \leq f \leq 1\}$$

is a vector field  $\hat{\eta}$  which coincides with  $\langle \xi \rangle$  near  $M_0, M_1$  and satisfies  $\hat{\eta} \cdot f = 1$ . The vector field

$$\eta = (\xi \cdot f)\hat{\eta}$$

extends to a vector field that coincides with  $\xi$  outside  $\{0 < f < 1\}$  and satisfies  $\langle \eta \rangle = \hat{\eta}$ . Moreover, the flow of  $\langle \eta \rangle$  fits in the commutative diagram

$$\begin{array}{ccc} M_1 & \xrightarrow{F} & M_1 \\ \Phi_{1,0}^\xi \uparrow & & \uparrow \Phi_{1,0}^\eta \\ M_0 & \xrightarrow{F} & M_0 \end{array}$$

Now observe that  $F|_{M_0} = \mathbb{1}_{M_0}$  and

$$F_{M_1} = \Phi_{1,1}^\xi h_1 \Phi_{1,1}^\xi = h_1 = h. \quad \square$$

**Lemma 2.29 (The moving lemma).** *Suppose  $X, Y$  are two smooth submanifolds of the compact smooth manifold  $V$  and  $X$  is compact. Then there exists a diffeomorphism of  $h : V \rightarrow V$  isotopic to the identity<sup>2</sup> such that  $h(X)$  intersects  $Y$  transversally.*  $\square$

We omit the proof which follows from the transversality results in [Hir, Chapter 3] and the isotopy extension theorem, [Hir, Chapter 8].

We can now complete the proof of Theorem 2.27. Let  $1 \leq k \leq \nu$ . Suppose we have constructed a gradient-like vector field  $\xi$  such that

$$W_{p_i}^+(\xi) \pitchfork W_{p_j}^-(\xi), \quad \forall i < j \leq k.$$

We will show that for  $\varepsilon > 0$  sufficiently small there exists a gradient-like vector field  $\eta$  which coincides with  $\xi$  outside the region  $\{c_{k+1} - 2\varepsilon < f < c_{k+1} - \varepsilon\}$  and such that

$$W_{p_{k+1}}^-(\eta) \pitchfork W_{p_j}^+(\eta), \quad \forall j \leq k.$$

For  $\varepsilon > 0$  sufficiently small, the manifold  $W_{p_{k+1}}^-(\xi)_{c_{k+1}-\varepsilon}$  is a sphere of dimension  $\lambda(p_{k+1}) - 1$  embedded in  $\{f = c_{k+1} - \varepsilon\}$ . We set

$$a := c_{k+1} - 2\varepsilon, \quad b := c_{k+1} - \varepsilon,$$

and

---

<sup>2</sup> The diffeomorphism  $h$  can be chosen to be arbitrarily  $C^0$ -close to the identity.

$$X_b = \bigcup_{j \leq k} W_{p_j}^+(\xi)_b.$$

Using the moving lemma, we can find a diffeomorphism  $h : M_b \rightarrow M_b$  isotopic to the identity such that (see Figure 2.14)

$$h(X_b) \cap W_{p_{k+1}}^-(\xi)_b. \tag{2.14}$$

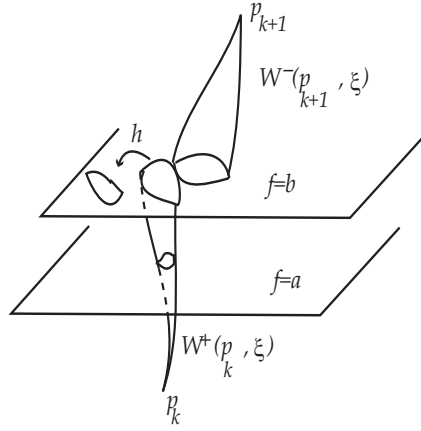

Fig. 2.14. Deforming a gradient-like flow.

Using the main deformation lemma we can find a gradient-like vector field  $\eta$  which coincides with  $\xi$  outside  $\{a < f < b\}$  such that

$$\Phi_{b,a}^\eta = h \circ \Phi_{b,a}^\xi.$$

Since  $\eta$  coincides with  $\xi$  outside  $\{a < f < b\}$ , we deduce

$$W_{p_j}^+(\eta)_a = W_{p_j}^+(\xi)_a, \quad \forall j \leq k, \quad W_{p_{k+1}}^-(\xi)_b = W_{p_{k+1}}^-(\eta)_b.$$

Now observe that

$$W_{p_j}^+(\eta)_b = \Phi_{b,a}^\eta W_{p_j}^+(\eta)_a = h \Phi_{b,a}^\xi W_{p_j}^+(\xi)_a = h W_{p_j}^+(\xi)_b,$$

and we deduce from (3.26) that

$$W_{p_j}^+(\eta)_b \cap W_{p_{k+1}}^-(\eta)_b, \quad \forall j \leq k.$$

Performing this procedure gradually, from  $k = 1$  to  $k = \nu$ , we obtain a gradient-like vector field with the properties stipulated in Theorem 2.27.  $\square$



**Definition 2.30.** (a) If  $f : M \rightarrow \mathbb{R}$  is a Morse function and  $\xi$  is a gradient like vector field such that

$$W_p^-(\xi) \pitchfork W_q^+(\xi), \quad \forall p, q \in \mathbf{Cr}_f,$$

then we say that  $(f, \xi)$  is a Morse–Smale pair on  $M$  and that  $\xi$  is a Morse–Smale vector field adapted to  $f$ .  $\square$

*Remark 2.31.* Observe that if  $(f, \xi)$  is a Morse–Smale pair on  $M$  and  $p, q \in \mathbf{Cr}_f$  are two *distinct* critical points such that  $\lambda_f(p) \leq \lambda_f(q)$ , then

$$W_p^-(\xi) \cap W_q^+(\xi) = \emptyset.$$

Indeed, suppose this is not the case. Then

$$\dim W_p^-(\xi) + \dim W_q^+(\xi) = \dim M + (\lambda(p) - \lambda(q)) \leq \dim M,$$

and because  $W_p^-(\xi)$  intersects  $W_q^+(\xi)$  transversally, we deduce that

$$\dim(W_p^-(\xi) \cap W_q^+(\xi)) = 0.$$

Since the intersection  $W_p^-(\xi) \cap W_q^+(\xi)$  is flow invariant and  $p \neq q$ , this zero dimensional intersection must contain at least one nontrivial flow line.  $\square$

**Definition 2.32.** A Morse function  $f : M \rightarrow \mathbb{R}$  is called self-indexing if

$$f(p) = \lambda_f(p), \quad \forall p \in \mathbf{Cr}_f. \quad \square$$

**Theorem 2.33 (Smale).** Suppose  $M$  is a compact smooth manifold of dimension  $m$ . Then there exist Morse–Smale pairs  $(f, \xi)$  on  $M$  such that  $f$  is self-indexing.

*Proof.* We follow closely the strategy in [M4, Section 4]. We begin by describing the main technique that allows us to gradually modify  $f$  to a self-indexing Morse function.

**Lemma 2.34 (Rearrangement lemma).** Suppose  $f : M \rightarrow \mathbb{R}$  is a Morse function such that  $0, 1$  are regular values of  $f$  and the region  $\{0 < f < 1\}$  contains precisely two critical points  $p_0, p_1$ . Furthermore, assume that  $\xi$  is a gradient-like vector field on  $M$  such that

$$W(p_0, \xi) \cap W(p_1, \xi) \cap \{0 \leq f \leq 1\} = \emptyset,$$

where we have used the notation  $W(p_i) = W_{p_i}^+ \cup W_{p_i}^-$ .

Then for any real numbers  $a_0, a_1 \in [0, 1]$  there exists a Morse function  $g : M \rightarrow \mathbb{R}$  with the following properties:

- (a)  $g$  coincides with  $f$  outside the region  $\{0 < f < 1\}$ .
- (b)  $g(p_i) = a_i, \forall i = 0, 1$ .
- (c)  $f - g$  is constant in a neighborhood of  $\{p_0, p_1\}$ .
- (d)  $\xi$  is a gradient-like vector field for  $g$ .

*Proof.* Let

$$\begin{aligned} W &:= \left( W_{p_0}^+(\xi) \cup W_{p_0}^-(\xi) \cup W_{p_1}^+(\xi) \cup W_{p_1}^-(\xi) \right) \cap \{0 \leq f \leq 1\}, \\ M_0 &:= \{f = 0\}, \quad M'_0 = M_0 \setminus (W_{p_0}^-(\xi) \cup W_{p_1}^-(\xi)), \\ W_{p_i}^-(\xi)_0 &:= W_{p_i}^-(\xi) \cap M_0. \end{aligned}$$

Denote by  $\langle \xi \rangle$  the vector field  $\frac{1}{\xi \cdot f} \xi$  on  $\{0 \leq f \leq 1\} \setminus W$  and by  $\Phi_t^\xi$  its flow. Then  $\Phi_t^\xi$  defines a diffeomorphism

$$\Psi : [0, 1] \times M'_0 \rightarrow \{0 \leq f \leq 1\} \setminus W, \quad (t, x) \mapsto \Phi_t^\xi(x).$$

Its inverse is

$$y \mapsto \Psi^{-1}(y) = (f(y), \Phi_{-f(y)}^\xi(y)).$$

Choose open neighborhoods  $U_i$  of  $W_{p_i}^-(\xi)_0$  in  $M_0$  such that  $U \cap U' = \emptyset$ . This is possible since  $W(p_0) \cap W(p_1) \cap M_0 = \emptyset$ .

Now fix a smooth function  $\mu : M_0 \rightarrow [0, 1]$  such that  $\mu = i$  on  $U_i$ . Denote by  $\hat{U}_i$  the set of points  $y$  in  $\{0 \leq f \leq 1\}$  such that, either  $y \in W_{p_i}^+(\xi)$ , or the trajectory of  $-\xi$  through  $y$  intersects  $M_0$  in  $U_i$ ,  $i = 0, 1$  (see Figure 2.15). We can extend  $\mu$  to a smooth function  $\hat{\mu}$  on  $\{0 \leq f \leq 1\}$  as follows.

If  $y \notin (\hat{U}_0 \cup \hat{U}_1)$ , then  $\Psi^{-1}(y) = (t, x)$ ,  $x \in M_0 \setminus (U_0 \cup U_1)$ , and we set

$$\hat{\mu}(y) := \mu(x).$$

Then we set  $\hat{\mu}(y) = i$ ,  $\forall y \in \hat{U}_i$ .

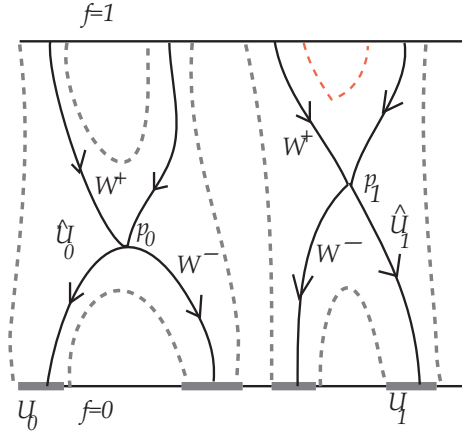

**Fig. 2.15.** Decomposing a Morse flow.

Now fix a smooth function  $G : [0, 1] \times [0, 1] \rightarrow [0, 1]$  satisfying the following conditions:

- $\frac{\partial G}{\partial t}(s, t) > 0, \forall 0 \leq s, t \leq 1.$
- $G(s, 0) = 0, G(s, 1) = 1.$
- $G(i, t) - t = (a_i - f(p_i))$  for  $t$  near  $f(p_i).$

We can think of  $G$  as a 1-parameter family of increasing diffeomorphisms

$$G_s : [0, 1] \rightarrow [0, 1], \quad s \mapsto G_s(t) = G(s, t)$$

such that  $G_0(f(p_0)) = a_0$  and  $G_1(f(p_1)) = a_1.$

Now define

$$h : \{0 \leq f \leq 1\} \rightarrow [0, 1], \quad h(y) = G(\hat{\mu}(y), f(y)).$$

It is now easy to check that  $g$  has all the desired properties.  $\square$

*Remark 2.35.* (a) To understand the above construction it helps to think of the Morse function  $f$  as a clock, i.e., a way of indicating the time when a flow line reaches a point. For example, the time at the point  $y$  is  $f(y).$

We can think of the family  $s \rightarrow G_s$  as 1-parameter family of “clock modifiers”. If a clock indicates time  $t \in [0, 1],$  then by modifying the clock with  $G_s$  it will indicate time  $G_s(t).$

The function  $h$  can be perceived as a different way of measuring time, obtained by modifying the “old clock”  $f$  using the modifier  $G_s.$  More precisely, the new time at  $y$  will be  $G_{\hat{\mu}(y)}(f(y)).$

(b) The rearrangement lemma works in the more general context, when instead of only two critical points, we have a partition  $C_0 \sqcup C_1$  of the set of critical points in the region  $\{0 < f < 1\}$  such that  $f$  is constant on  $C_0$  and on  $C_1,$  and  $W(p_0, \xi) \cap W(p_1, \xi) = \emptyset, \forall p_0 \in C_0, \forall p_1 \in C_1.$   $\square$

We can now complete the proof of Theorem 2.33. Suppose that  $(f, \xi)$  is a Morse–Smale pair on  $M$  such that  $f$  is nonresonant. Remark 2.31 shows that

$$p \neq q \text{ and } \lambda(p) \leq \lambda(q) \implies W_p^-(\xi) \cap W_q^+(\xi) = \emptyset.$$

We say that a pair  $(p, q)$  of critical points,  $p, q \in \mathbf{Cr}_f$  is an *inversion* if

$$f(p) > f(q) \text{ and } \lambda(p) < \lambda(q).$$

We see that if  $(p, q)$  is an inversion, then

$$W_p^-(\xi) \cap W_q^+(\xi) = \emptyset.$$

Using the rearrangement lemma and Theorem 2.27 we can produce inductively a new Morse–Smale pair  $(g, \eta)$  such that  $\mathbf{Cr}_g = \mathbf{Cr}_f,$  and  $g$  is nonresonant and has no inversions.

To see how this is done, define the *level function*

$$\ell_f : \mathbf{Cr}_f \rightarrow \mathbb{Z}_{\geq 0}, \quad \ell(p) := \#\{q \in \mathbf{Cr}_f; f(q) < f(p)\}.$$

In other words,  $\ell_f(p)$  is the number of critical point of  $f$  with smaller energy<sup>3</sup> than  $p$ . Denote by  $\nu(f)$  the number of inversions of  $f$ , and then set

$$\mu(f) = \max\{\ell_f(q); \exists p \in \mathbf{Cr}_f \text{ such that } (p, q) \text{ inversion of } f\}.$$

If  $\nu(f) > 0$ , then there exists an inversion  $(p, q)$  such that

$$\ell_f(q) = \mu(f) \text{ and } \ell(p) = \ell_f(q) + 1 = \mu(f) + 1.$$

We can then use the rearrangement lemma to replace  $f$  with a new function  $f'$  such that  $\nu(f') < \nu(f)$ .

This implies that there exist regular values  $r_0 < r_1 < \dots < r_m$  such that all the critical points in the region  $\{r_\lambda < g < r_{\lambda+1}\}$  have the same index  $\lambda$ .

Using the rearrangement lemma again (see Remark 2.35(b)) we produce a new Morse-Smale pair  $(h, \tau)$  with critical values  $c_0 < \dots < c_m$ , and all the critical points on  $\{h = c_\lambda\}$  have the same index  $\lambda$ .

Finally, via an increasing diffeomorphism of  $\mathbb{R}$  we can arrange that  $c_\lambda = \lambda$ .  $\square$

Observe that the above arguments prove the following slightly stronger result.

**Corollary 2.36.** *Suppose  $(f, \xi)$  is a Morse-Smale pair on the compact manifold  $M$ . Then we can modify  $f$  to a smooth Morse function  $g : M \rightarrow \mathbb{R}$  with the following properties:*

- (a)  $\mathbf{Cr}_g = \mathbf{Cr}_f$  and  $\lambda(f, p) = \lambda(g, p) = g(p)$ ,  $\forall p \in \mathbf{Cr}_f = \mathbf{Cr}_g$ .
- (b)  $\xi$  is a gradient-like vector field for  $g$ .

*In particular,  $(g, \xi)$  is a self-indexing Morse-Smale pair.*  $\square$

Here is a simple application of this corollary. We define a *handlebody* to be a 3-dimensional manifold with boundary obtained by attaching 1-handles to a 3-dimensional ball. A *Heegard decomposition* of a smooth, compact, connected 3-manifold  $M$  is a quadruple  $(H_-, H_+, f, \Phi)$  satisfying the following conditions.

- $H_\pm$  are handlebodies.
- $f$  is an orientation reversing diffeomorphism  $f : \partial H_- \rightarrow \partial H_+$ .
- $\Phi$  is a homeomorphism from  $M$  to the space  $H_- \cup_f H_+$  obtained by gluing  $H_-$  to  $H_+$  along their boundaries using the identification prescribed by  $f$ .

**Theorem 2.37.** *Any smooth compact connected 3-manifolds admits a Heegard decomposition.*

<sup>3</sup> Here we prefer to think of  $f$  as energy.

*Proof.* Fix a self-indexing Morse–Smale pair  $(f, \xi)$  on  $M$ . The critical values of  $f$  are contained in  $\{0, 1, 2, 3\}$ . To prove the claim in the theorem it suffices to show that the manifolds with boundary

$$H_-(f) := \left\{ f \leq \frac{3}{2} \right\} \quad \text{and} \quad H_+(f) := \left\{ f \geq \frac{3}{2} \right\}$$

are handlebodies. We do this only for  $H_-$ . The case  $H_+(f)$  is completely similar since  $H_+(f) = H_-(3 - f)$ .

Observe first that  $H_-$  is connected. Indeed, the connected manifold  $M$  is obtained from  $H_-$  by attaching 2 and 3-handles and these operations do not change the number of connected components.

The sublevel set  $\{f \leq \varepsilon\}$ ,  $\varepsilon \in (0, 1)$ , is the disjoint union of a collection of 3-dimensional balls, one ball for every minimum point of  $f$ . The manifold  $H_-$  is obtained from this disjoint union of balls by attaching 1-handles, one for each critical point of index 1.

We can encode this description as a graph  $\Gamma$ . The vertices of  $\Gamma$  correspond to the connected components of  $\{f \leq \varepsilon\}$ , while the edges correspond to the attached 1-handles. The endpoint(s) of an edge indicate how the attaching is performed. The graph  $\Gamma$  may have loops, i.e., edges that start and end at the same vertex. To such a loop it corresponds a 1-handle attached to a single component of  $\{f \leq \varepsilon\}$ .

Since  $H_-$  is connected, so is  $\Gamma$ . Let  $T$  be a spanning tree of  $\Gamma$ , i.e., a simply connected subgraph of  $\Gamma$  with the same vertex set as  $\Gamma$ . By attaching first the 1-handles corresponding to the edges of  $T$  we obtain a manifold  $H(T)$  diffeomorphic to a 3-dimensional ball. This shows that  $H_-$  is obtained by attaching 1-handles to the 3-dimensional ball  $H(T)$ , so that  $H_-$  is a handlebody.  $\square$

## 2.5 Morse–Floer Homology

Suppose that  $(f, \xi)$  is a Morse–Smale pair on the compact  $m$ -dimensional manifold  $M$  such that  $f$  is self-indexing. In particular, the real numbers  $k + \frac{1}{2}$  are regular values of  $f$ . We set

$$M_k = \left\{ f \leq k + \frac{1}{2} \right\}, \quad Y_k = \left\{ k - \frac{1}{2} \leq f \leq k + \frac{1}{2} \right\}.$$

Then  $Y_k$  is a smooth manifold with boundary (see Figure 2.16)

$$\partial Y_k = \partial_- Y_k \cup \partial_+ Y_k, \quad \partial_{\pm} Y_k = \left\{ f = k \pm \frac{1}{2} \right\}.$$

Set

$$C_k(f) := H_k(M_k, M_{k-1}; \mathbb{Z}), \quad \mathbf{Cr}_{f,k} := \{p \in \mathbf{Cr}_f; \lambda(p) = k\} \subset \{f = k\}.$$

Finally, for  $p \in \mathbf{Cr}_{f,k}$  denote by  $D_p^{\pm}$  the unstable disk

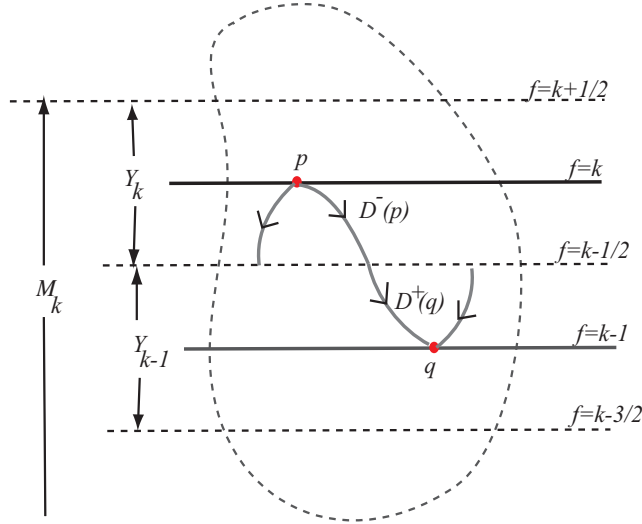

Fig. 2.16. Constructing the Thom-Smale complex.

$$D_p^\pm := W_p^\pm(\xi) \cap Y_k.$$

Using the excision theorem and the fundamental structural theorem of Morse theory we obtain an isomorphism

$$C_k(f) \cong \bigoplus_{p \in \mathbf{Cr}_k} H_k(D_p^-, \partial D_p^-; \mathbb{Z}).$$

By fixing an orientation  $\mathbf{or}^-(p)$  on each unstable manifold  $W_p^-$  we obtain isomorphisms

$$H_k(D_p^-, \partial D_p^-; \mathbb{Z}) \rightarrow \mathbb{Z}, \quad p \in \mathbf{Cr}_{f,k}.$$

We denote by  $\langle p \rangle$  the generator of  $H_k(D_p^-, \partial D_p^-; \mathbb{Z})$  determined by the choice of orientation  $\mathbf{or}^-(p)$ .

Observe that we have a natural morphism  $\partial : C_k \rightarrow C_{k-1}$  defined as the composition

$$H_k(M_k, M_{k-1}; \mathbb{Z}) \rightarrow H_{k-1}(M_{k-1}, \mathbb{Z}) \rightarrow H_{k-1}(M_{k-1}, M_{k-2}; \mathbb{Z}). \quad (2.15)$$

Arguing exactly as in the proof of [Ha, Theorem 2.35] (on the equivalence of cellular homology with the singular homology)<sup>4</sup> we deduce that

<sup>4</sup> For the cognoscenti. The increasing filtration  $\cdots \subset M_{k-1} \subset M_k \subset \cdots$  defines an increasing filtration on the singular chain complex  $C_\bullet(M, \mathbb{Z})$ . The associated (homological) spectral sequence has the property that  $E_{p,q}^2 = 0$  for all  $q > 0$  so that the spectral sequence degenerates at  $E^2$  and the edge morphism induces an isomorphism  $H_p(M) \rightarrow E_{p,0}^2$ . The  $E^1$  term is precisely the chain complex (2.16).

$$\cdots \rightarrow C_k(f) \xrightarrow{\partial} C_{k-1}(f) \rightarrow \cdots \quad (2.16)$$

is a chain complex whose homology is isomorphic to the homology of  $M$ . This is called the *Thom–Smale complex* associated to the self-indexing Morse function  $f$ .

We would like to give a more geometric description of the Thom–Smale complex. More precisely, we will show that it is isomorphic to a chain complex which can be described entirely in terms of Morse data.

Observe first that the connecting morphism

$$\partial_k : H_k(M_k, M_{k-1}) \rightarrow H_{k-1}(M_{k-1})$$

can be geometrically described as follows. The relative class  $\langle p \rangle \in C_k$  is represented by the fundamental class of the *oriented* manifold with boundary  $(D_p^-, \partial D_p^-)$ . The orientation  $\mathbf{or}_p^-$  induces an orientation on  $\partial D_p^-$ , and thus the oriented closed manifold  $\partial D_p^-$  defines a homology class in  $H_{k-1}(M_{k-1}, \mathbb{Z})$  which represents  $\partial \langle p \rangle$ .

Assume for simplicity that the ambient manifold  $M$  is *oriented*. (As explained Remark 2.40 (a) this assumption is not needed.) The orientation  $\mathbf{or}_M$  on  $M$  and the orientation  $\mathbf{or}_p^-$  on  $D_p^-$  determine an orientation  $\mathbf{or}_p^+$  on  $D_p^+$  via the equalities

$$T_p M = T_p D_p^- \oplus T_p D_p^+, \quad \mathbf{or}_p^- \wedge \mathbf{or}_p^+ = \mathbf{or}_M.$$

Since  $\xi$  is a Morse–Smale gradient like vector field, we deduce that  $\partial D_p^-$  and  $D_q^+$  intersect transversally. In particular, if  $p \in \mathbf{Cr}_{f,k}$  and  $q \in \mathbf{Cr}_{f,k-1}$ , then

$$\dim \partial D_p^- + \dim D_q^+ = (k-1) + \dim M - (k-1) = m,$$

so that  $\partial D_p^-$  intersects  $D_q^+$  transversally in finitely many points. We denote by  $\langle p|q \rangle$  the *signed* intersection number

$$\langle p|q \rangle := \#(\partial D_p^- \cap D_q^+), \quad p \in \mathbf{Cr}_{f,k}, \quad q \in \mathbf{Cr}_{f,k-1}.$$

Observe that each point  $s$  in  $\partial D_p^- \cap D_q^+$  corresponds to a unique trajectory  $\gamma(t)$  of the flow generated by  $-\xi$  such that  $\gamma(-\infty) = p$  and  $\gamma(\infty) = q$ . We will refer to such a trajectory as a *tunneling* from  $p$  to  $q$ . Thus  $\langle p|q \rangle$  is a signed count of tunnelings from  $p$  to  $q$ .

**Proposition 2.38 (Thom–Smale).** *There exists  $\epsilon_k \in \{\pm 1\}$  such that*

$$\partial \langle p \rangle = \epsilon_k \sum_{q \in \mathbf{Cr}_{f,k-1}} \langle p|q \rangle \cdot \langle q \rangle, \quad \forall p \in \mathbf{Cr}_{f,k}. \quad (2.17)$$

*Proof.* We have

$$\partial \langle p \rangle \in H_{k-1}(M_{k-1}, M_{k-2}; \mathbb{Z}) \cong H_{k-1}(Y_{k-1}, \partial_- Y_{k-1}; \mathbb{Z}).$$

From the Poincaré–Lefschetz duality theorem we deduce

$$H_{k-1}(Y_{k-1}, \partial_- Y_{k-1}; \mathbb{Z}) \cong H^{m-(k-1)}(Y_{k-1}, \partial_+ Y_{k-1}; \mathbb{Z}).$$

Since  $H_j(Y_{k-1}, \partial_+ Y_{k-1}; \mathbb{Z})$  is a free Abelian group nontrivial only for  $j = m - (k - 1)$  we deduce that the canonical map

$$H^{m-(k-1)}(Y_{k-1}, \partial_+ Y_{k-1}; \mathbb{Z}) \longrightarrow \text{Hom}(H_{m-(k-1)}(Y_{k-1}, \partial_+ Y_{k-1}; \mathbb{Z}), \mathbb{Z})$$

given by the Kronecker pairing is an isomorphism.

The group  $H_{m-(k-1)}(Y_{k-1}, \partial_+ Y_{k-1}; \mathbb{Z})$  is freely generated by<sup>5</sup>

$$|q\rangle := [D_q^+, \partial D_q^+, \mathbf{or}_q^+], \quad q \in \mathbf{Cr}_{f,k-1}.$$

If we view  $\partial\langle p|$  as a morphism  $H_{m-(k-1)}(Y_{k-1}, \partial_+ Y_{k-1}; \mathbb{Z}) \longrightarrow \mathbb{Z}$ , then its value on  $|q\rangle$  is given (up to a sign  $\epsilon_k$  which depends only on  $k$ ) by the above intersection number  $\langle p|q\rangle$ .  $\square$

Given a Morse–Smale pair  $(f, \xi)$  on an oriented manifold  $M$  and orientations of the unstable manifolds, we can form the *Morse–Floer complex*

$$(C_\bullet(f), \partial), \quad C_k(f) = \bigoplus_{p \in \mathbf{Cr}_k(f)} \mathbb{Z} \cdot \langle p|,$$

where the boundary operator has the tunnelling description (2.17). Note that the definitions of  $C_k(f)$  and  $\partial$  depend on  $\xi$  but not on  $f$ .

In view of Corollary 2.36 we may as well assume that  $f$  is self-indexing. Indeed, if this is not the case, we can replace  $f$  by a different Morse function  $g$  with the same critical points and indices such that  $g$  is self-indexing and  $\xi$  is a gradient-like vector field for both  $f$  and  $g$ .

We conclude that  $\partial$  is indeed a boundary operator, i.e.,  $\partial^2 = 0$ , because it can alternatively be defined as the composition (2.15). We have thus proved the following result.

**Corollary 2.39.** *For any Morse–Smale pair  $(f, \xi)$  on the compact oriented manifold  $M$  there exists an isomorphism from the homology of the Morse–Floer complex to the singular homology of  $M$ .*  $\square$

*Remark 2.40.* (a) The orientability assumption imposed on  $M$  is not necessary. We used it only for the ease of presentation. Here is how one can bypass it.

Choose for every  $p \in \mathbf{Cr}_f$  orientations of the vector subspaces  $T_p^- M \subset T_p M$  spanned by the eigenvectors of the Hessian of  $f$  corresponding to negative eigenvalues. The unstable manifold  $W_p^-$  is homeomorphic to a vector space and its tangent space at  $p$  is precisely  $T_p^- M$ . Thus, the chosen orientation

<sup>5</sup> There is no typo!  $|q\rangle$  is a *ket* vector and *not* a *bra* vector  $\langle q|$ .



on  $T_p^- M$  induces an orientation on  $W_p^-$ . Similarly, the chosen orientation on  $T_p^- M$  defines an orientation on the normal bundle  $T_{W_p^+} M$  of the embedding  $W_p^+ \hookrightarrow M$ .

Now observe that if  $X$  and  $Y$  are submanifolds in  $M$  intersecting transversally, such that  $TX$  is oriented and the normal bundle  $T_Y M$  of  $Y \hookrightarrow M$  is oriented, then there is a canonical orientation of  $X \cap Y$ . Indeed, the normal bundle of  $X \cap Y \hookrightarrow X$  is naturally isomorphic to the restriction to  $X \cap Y$  of the normal bundle of  $Y$  in  $M$ , i.e., we have a natural short exact sequence of bundles

$$0 \rightarrow T(X \cap Y) \hookrightarrow (TX)|_{X \cap Y} \rightarrow (T_Y M)|_{X \cap Y} \rightarrow 0.$$

Hence, if  $\lambda(p) - \lambda(q) = 1$ , then  $W_p^- \cap W_q^+$  is an oriented one-dimensional manifold.

On the other hand, each component of  $W_p^- \cap W_q^+$  is a trajectory of the gradient flow and thus comes with another orientation given by the direction of the flow.

We conclude that on each component of  $W_p^- \cap W_q^+$  we have a pair of orientations which differ by a sign  $\epsilon$ . We can now define  $n(p, q)$  to be the sum of all these  $\epsilon$ 's. We then get an operator

$$\hat{\partial} : C_k(f) \rightarrow C_{k-1}(f), \quad \hat{\partial}\langle p \rangle = \sum_q n(p, q)\langle q \rangle.$$

One can prove that it coincides, up to an overall sign, with the previous boundary operator.

(b) For different proofs of the above corollary we refer to [BaHu, Sal, Sch].

(c) Corollary 2.39 has one unsatisfactory feature. The isomorphism is not induced by a morphism between the Morse–Floer complex and the singular chain complexes and thus does not highlight the geometric nature of this construction.

For any homology class in a smooth manifold  $M$ , the Morse–Smale flow  $\Phi_t$  on  $M$  selects a very special singular chain representing this class. For example, if a homology class is represented by the singular cycle  $c$ , then is also represented by the cycle  $\Phi_t(c)$  and, stretching our imagination, by the cycle  $\Phi_\infty(c) = \lim_{t \rightarrow \infty} \Phi_t(c)$ .

The Morse–Floer complex is, loosely speaking, the subcomplex of the singular complex generated by the family of singular simplices of the form  $\Phi_\infty(\sigma)$ , where  $\sigma$  is a singular simplex. The supports of such asymptotic simplices are invariant subsets of the Morse–Smale flow and thus must be unions of orbits of the flow.

The isomorphism between the Morse–Floer homology and the singular homology suggests that the subcomplex of the singular chain complex generated by asymptotic simplices might be homotopy equivalent to the singular chain complex. For a rigorous treatment of this idea we refer to [BFK], [Lau] or [HL].

There is another equivalent way of visualizing the Morse flow complex which goes back to R. Thom [Th]. Think of a Morse–Smale pair  $(f, \xi)$  on  $M$  as defining a “polyhedral structure, and then the Morse–Floer complex is the complex naturally associated to this structure. The faces of this “polyhedral structure” are labelled by the critical points of  $f$ , and their interiors coincide with the unstable manifolds of the corresponding critical point.

The boundary of a face is a union (with integral multiplicities) of faces of one dimension lower. To better understand this point of view it helps to look at the simple situation depicted in Figure 2.17. Let us explain this figure.

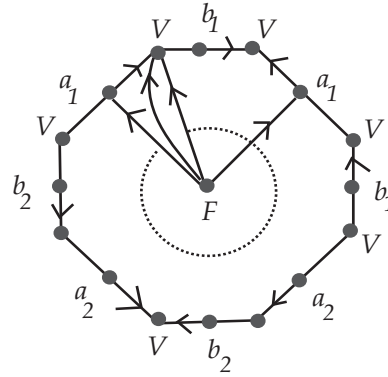

**Fig. 2.17.** The polyhedral structure determined by a Morse function on a Riemann surface of genus 2.

First, we have the standard description of a Riemann surface of genus 2 obtained by identifying the edges of an 8-gon with the gluing rule

$$a_1 b_1 a_1^{-1} b_1^{-1} a_2 b_2 a_2^{-1} b_2^{-1}.$$

This polyhedral structure corresponds to a Morse function on the Riemann surface which has the following structure.

- There is a single critical point of index 2, denoted by  $F$ , and located in the center of the two-dimensional face. The relative interior of the top face is the unstable manifold of  $F$ , and all the trajectories contained in this face will leave  $F$  and end up either at a vertex or in the center of some edge.
- There are four critical points of index one,  $a_1, a_2, b_1, b_2$ , located at the center of the edges labelled by the corresponding letter. The interiors of the edges are the corresponding one-dimensional unstable manifolds. The arrows along the edges describe orientations on these unstable manifolds. The gradient flow trajectories along an edge point away from the center.
- There is a unique critical point of index 0 denoted by  $V$ .

In the picture there are two tunnellings connecting  $F$  with  $a_1$ , but they are counted with opposite signs. In general, we deduce

$$\langle F|a_i \rangle = \langle F|b_j \rangle = 0, \quad \forall i, j.$$

Similarly,

$$\langle a_i|V \rangle = \langle b_j|V \rangle = 0, \quad \forall i, j.$$

The existence of a similar polyhedral structure in the general case was recently established in [Qin]. We refer to Chapter 4 for more details.

(d) The dynamical description of the boundary map of the Morse–Floer complex in terms of tunnellings is due to Witten, [Wit] (see the nice story in [B3]), and it has become popular through the groundbreaking work of A. Floer, [Fl]. In Section 4.5 we will take a closer look at this dynamical interpretation.

The tunnelling approach has been used quite successfully in infinite dimensional situations leading to various flavors of the so called *Floer homologies*.

These are situations when the stable and unstable manifolds are infinite dimensional yet they intersect along finite dimensional submanifolds. One can still form the operator  $\partial$  using the description in Proposition 2.38, but the equality  $\partial^2 = 0$  is no longer obvious, because in this case an alternative description of  $\partial$  of the type (2.15) is lacking. For more information on this aspect we refer to [ABr, Sch].

□

## 2.6 Morse–Bott Functions

Suppose  $f : M \rightarrow \mathbb{R}$  is a smooth function on the  $m$ -dimensional manifold  $M$ .

**Definition 2.41.** *A smooth submanifold  $S \hookrightarrow M$  is said to be a nondegenerate critical submanifold of  $f$  if the following hold.*

- $S$  is compact and connected.
- $S \subset \mathbf{Cr}_f$ .
- $\forall s \in S$  we have  $T_s S = \ker H_{f,s}$ , i.e.,

$$H_{f,s}(X, Y) = 0, \quad \forall Y \in T_s M \iff X \in T_s S (\subset T_s M).$$

*The function  $f$  is called a Morse–Bott function if its critical set consists of nondegenerate critical submanifolds.* □

Suppose  $S \hookrightarrow M$  is a nondegenerate critical submanifold of  $f$ . Assume for simplicity that  $f|_S = 0$ . Denote by  $T_S M$  the normal bundle of  $S \hookrightarrow M$ ,  $T_S M := (TM)|_S / TS$ . For every  $s \in S$  and every  $X, Y \in T_s S$  we have

$$H_{f,s}(X, Y) = 0,$$

so that the Hessian of  $f$  at  $s$  induces a quadratic form  $Q_{f,s}$  on  $T_sM/T_sS = (T_sM)_s$ . We thus obtain a quadratic form  $Q_f$  on  $T_sM$ , which we regard as a function on the total space of  $T_sM$ , quadratic along the fibers.

The same arguments in the proof of Theorem 1.12 imply the following *Morse lemma with parameters*. For details we refer to [H3, Appendix C.6].

**Proposition 2.42.** *There exists an open neighborhood  $U$  of  $S \hookrightarrow E = T_sM$  and a smooth open embedding  $\Phi : U \rightarrow M$  such that  $\Phi|_S = \mathbb{1}_S$  and*

$$\Phi^* f = \frac{1}{2} Q_f.$$

If we choose a metric  $g$  on  $E$ , then we can identify the Hessians  $Q_{f,s}$  with a symmetric automorphism  $Q : E \rightarrow E$ . This produces an orthogonal decomposition

$$E = E^+ \oplus E^-,$$

where  $E_{\pm}$  is spanned by the eigenvectors of  $H$  corresponding to positive/negative eigenvalues. If we denote by  $r_{\pm}$  the restriction to  $E_{\pm}$  of the function

$$u(v, s) = g_s(v, v),$$

then we can choose the above  $\Phi$  so that

$$\Phi^* f = -u_- + u_+.$$

The topological type of  $E^{\pm}$  is independent of the various choices, and thus it is an invariant of  $(S, f)$  denoted by  $E^{\pm}(S)$  or  $E^{\pm}(S, f)$ . We will refer to  $E^-(S)$  as the negative normal bundle of  $S$ . In particular, the rank of  $E^-$  is an invariant of  $S$  called the Morse index of the critical submanifold  $S$ , and it is denoted by  $\lambda(f, S)$ . The rank of  $E^+$  is called the Morse coindex of  $S$ , and it is denoted by  $\hat{\lambda}(f, S)$ .  $\square$

**Definition 2.43.** *Let  $\mathbb{F}$  be a field. The  $\mathbb{F}$ -Morse–Bott polynomial of a Morse–Bott function  $f : M \rightarrow \mathbb{R}$  defined on the compact manifold  $M$  is the polynomial*

$$P_f(t) = P_f(t; \mathbb{F}) = \sum_S t^{\lambda(f, S)} P_{S, \mathbb{F}}(t),$$

where the summation is over all the critical submanifolds of  $f$ . Note that the Morse–Bott polynomial of a Morse function coincides with the Morse polynomial defined earlier.  $\square$

Arguing exactly as in the proof of the fundamental structural theorem we obtain the following result.

**Theorem 2.44 (Bott).** *Suppose  $f : M \rightarrow \mathbb{R}$  is an exhaustive smooth function and  $c \in \mathbb{R}$  is a critical value such that  $\mathbf{Cr}_f \cap f^{-1}(c)$  consists of finitely*

many critical submanifolds  $S_1, \dots, S_k$ . For  $i = 1, \dots, k$  denote by  $D_{S_i}^-$  the (closed) unit disk bundle of  $E^-(S_i)$  (with respect to some metric on  $E^-(S_i)$ ). Then for  $\varepsilon > 0$  the sublevel set  $M^{c+\varepsilon} = \{f \leq c + \varepsilon\}$  is homotopic to the space obtained from  $M^{c-\varepsilon} = \{f \leq c - \varepsilon\}$  by attaching the disk bundles  $D_{S_i}^-$  to  $M^{c-\varepsilon}$  along the boundaries  $\partial D_{S_i}^-$ . In particular, for every field  $\mathbb{F}$  we have an isomorphism

$$H_\bullet(M^{c+\varepsilon}, M^{c-\varepsilon}; \mathbb{F}) = \bigoplus_{i=1}^k H_\bullet(D^-(S_i), \partial D^-(S_i); \mathbb{F}). \quad (2.18)$$

□

Let  $\mathbb{F}$  be a field and  $X$  a compact CW-complex. For a real vector bundle  $\pi : E \rightarrow X$  of rank  $r$  over  $X$ , we denote by  $D(E)$  the unit disk bundle of  $E$  with respect to some metric. We say that  $E$  is  $\mathbb{F}$ -orientable if there exists a cohomology class

$$\tau \in H^r(D(E), \partial D(E); \mathbb{F})$$

such that its restriction to each fiber  $(D(E)_x, \partial D(E)_x)$ ,  $x \in X$  defines a generator of the relative cohomology group  $H^r(D(E)_x, \partial D(E)_x; \mathbb{F})$ . The class  $\tau$  is called the *Thom class* of  $E$  associated to a given orientation.

For example, every vector bundle is  $\mathbb{Z}/2$ -orientable, and every complex vector bundle is  $\mathbb{Q}$ -orientable. Every real vector bundle over a simply connected space is  $\mathbb{Q}$ -orientable.

The *Thom isomorphism theorem* states that if the vector bundle  $\pi : E \rightarrow X$  is  $\mathbb{F}$ -orientable, then for every  $k \geq 0$  the morphism

$$H^k(X, \mathbb{F}) \ni \alpha \longmapsto \tau_E \cup \pi^* \alpha \in H^{k+r}(D(E), \partial D(E); \mathbb{F})$$

is an isomorphism for any  $k \in \mathbb{Z}$ . Equivalently, the transpose map

$$H_{k+r}(D(E), \partial D(E); \mathbb{F}) \rightarrow H_k(X, \mathbb{F}), \quad c \mapsto \pi_*(c \cap \tau_E)$$

is an isomorphism. This implies

$$P_{D(E), \partial D(E)}(t) = t^r P_X(t). \quad (2.19)$$

**Definition 2.45.** Suppose  $\mathbb{F}$  is a field, and  $f : M \rightarrow \mathbb{R}$  is a Morse–Bott function. We say that  $f$  is  $\mathbb{F}$ -orientable if for every critical submanifold  $S$  the bundle  $E^-(S)$  is  $\mathbb{F}$ -orientable. □

**Corollary 2.46.** Suppose  $f : M \rightarrow \mathbb{R}$  is an  $\mathbb{F}$ -orientable Morse–Bott function on the compact manifold. Then we have the Morse–Bott inequalities

$$P_f(t) \succ P_{M, \mathbb{F}}(t).$$

In particular,

$$\sum_S (-1)^{\lambda(f,S)} \chi(S) = P_f(-1) = P_M(-1) = \chi(M).$$

*Proof.* Denote by  $c_1 < \dots < c_\nu$  the critical values of  $f$  and set

$$t_k = \frac{c_k + c_{k+1}}{2}, \quad k = 1, \nu - 1, \quad t_0 = c_1 - 1, \quad t_\nu = c_\nu + 1, \quad M_k = \{f \leq t_k\}.$$

As explained in Remark 2.16, we have an inequality

$$\sum_k P_{M_k, M_{k-1}} \succcurlyeq P_M.$$

Using the equality (2.18) we deduce

$$\sum_k P_{M_k, M_{k-1}} = \sum_S P_{D_S^-, \partial D_S^-},$$

where the summation is over all the critical submanifolds of  $f$ . Since  $E^-(S)$  is orientable for every  $S$ , we deduce from (2.19) that

$$P_{D_S^-, \partial D_S^-} = t^{\lambda(f,S)} P_S. \quad \square$$

**Definition 2.47.** Suppose  $f : M \rightarrow \mathbb{R}$  is a Morse–Bott function on a compact manifold  $M$ . For  $a \in \mathbb{R}$  we set  $M^a := \{f \leq a\}$ . Then  $f$  is called  $\mathbb{F}$ -completable if for every critical value  $c$  and every critical submanifold  $S \subset f^{-1}(c)$  the morphism

$$H^\bullet(D_S^-, \partial D_S^-; \mathbb{F}) \rightarrow H^\bullet(M^{c+\varepsilon}, M^{c-\varepsilon}; \mathbb{F}) \xrightarrow{\partial} H^{\bullet-1}(M^{c-\varepsilon}, \mathbb{F})$$

is trivial.  $\square$

Arguing exactly as in the proof of Proposition 2.17 we obtain the following result.

**Theorem 2.48.** Suppose  $f : M \rightarrow \mathbb{R}$  is a  $\mathbb{F}$ -completable,  $\mathbb{F}$ -orientable, Morse–Bott function on a compact manifold. Then  $f$  is  $\mathbb{F}$ -perfect, i.e.,  $P_f(t) = P_M(t)$ .  $\square$

**Corollary 2.49.** Suppose  $f : M \rightarrow \mathbb{R}$  is an orientable Morse–Bott function such that for every critical submanifold  $M$  we have  $\lambda(f, S) \in 2\mathbb{Z}$  and  $P_S(t)$  is even, i.e.,

$$b_k(S) \neq 0 \implies k \in 2\mathbb{Z}.$$

Then  $f$  is  $\mathbb{Q}$ -perfect and thus  $P_f(t) = P_M(t)$ .

*Proof.* Using the same notation as in the proof of Corollary 2.46, we deduce by induction over  $k$  from the long exact sequences of the pairs  $(M_k, M_{k-1})$  that  $b_j(M_k) = 0$  if  $j$  is odd, and we have short exact sequence

$$0 \rightarrow H_j(M_{k-1}) \rightarrow H_j(M_k) \rightarrow H_j(M_k, M_{k-1}) \rightarrow 0$$

if  $j$  is even.  $\square$

## 2.7 Min–Max Theory

So far we have investigated how to use information about the critical points of a smooth function on a smooth manifold to extract information about the manifold itself. In this section we will turn the situation on its head. We will use topological methods to extract information about the critical points of a smooth function.

To keep the technical details to a minimum so that the geometric ideas are as transparent as possible, we will restrict ourselves to the case of a smooth function  $f$  on a *compact, connected* smooth manifold  $M$  without boundary equipped with a Riemannian metric  $g$ .

We can substantially relax the compactness assumption, and the same geometrical principles we will outline below will still apply, but that will require additional technical work.

Morse theory shows that if we have some information about the critical points of  $f$  we can obtain lower estimates for their number. For example, if all the critical points are nondegenerate, then their number is bounded from below by the sum of Betti numbers of  $M$ . What happens if we drop the nondegeneracy assumption? Can we still produce interesting lower bounds for the number of critical points?

We already have a very simple lower bound. Since a function on a compact manifold must have a minimum and a maximum, it must have at least two critical points. This lower bound is in some sense optimal because the height function on the round sphere has precisely two critical points. This optimality is very unsatisfactory since, as pointed out by G. Reeb in [Re], if the only critical points of  $f$  are (nondegenerate) minima and maxima, then  $M$  must be homeomorphic to a sphere.

Min-max theory is quite a powerful technique for producing critical points that often are saddle type points. We start with the basic structure of this theory. For simplicity we denote by  $M^c$  the sublevel set  $\{f \leq c\}$ .

The min-max technology requires a special input.

**Definition 2.50.** *A collection of min-max data for the smooth function*

$$f : M \rightarrow \mathbb{R}$$

*is a pair  $(\mathcal{H}, \mathcal{S})$  satisfying the following conditions.*

- $\mathcal{H}$  is a collection of homeomorphisms of  $M$  such that for every regular value  $a$  of  $M$  there exist  $\varepsilon > 0$  and  $h \in \mathcal{H}$  such that

$$h(M^{a+\varepsilon}) \subset M^{a-\varepsilon}.$$

- $\mathcal{S}$  is a collection of subsets of  $M$  such that

$$h(S) \in \mathcal{S}, \quad \forall h \in \mathcal{H}, \quad \forall S \in \mathcal{S}. \quad \square$$

The key existence result of min-max theory is the following.

**Theorem 2.51 (Min-max principle).** *If  $(\mathcal{H}, \mathcal{S})$  is a collection of min-max data for the smooth function  $f : M \rightarrow \mathbb{R}$ , then the real number*

$$c = c(\mathcal{H}, \mathcal{S}) := \inf_{S \in \mathcal{S}} \sup_{x \in S} f(x)$$

*is a critical value of  $f$ .*

*Proof.* We argue by contradiction. Assume that  $c$  is a regular value. Then there exist  $\varepsilon > 0$  and  $h \in \mathcal{H}$  such that

$$h(M^{c+\varepsilon}) \subset M^{c-\varepsilon}.$$

From the definition of  $c$  we deduce that there exists  $S \in \mathcal{S}$  such that  $\sup_{x \in S} f(x) < c + \varepsilon$ , that is,

$$S \subset M^{c+\varepsilon}.$$

Then  $S' = h(S) \in \mathcal{S}$  and  $h(S) \subset M^{c-\varepsilon}$ . It follows that  $\sup_{x \in S'} f(x) \leq c - \varepsilon$ , so that

$$\inf_{S' \in \mathcal{S}} \sup_{x \in S'} f(x) \leq c - \varepsilon.$$

This contradicts the choice of  $c$  as a min-max value.  $\square$

The usefulness of the min-max principle depends on our ability to produce interesting min-max data. We will spend the remainder of this section describing a few classical constructions of min-max data.

In all these constructions the family of homeomorphisms  $\mathcal{H}$  will be the same. More precisely, we fix gradient-like vector field  $\xi$  and we denote by  $\Phi_t$  the flow generated by  $-\xi$ . The condition (a) in the definition of min-max data is clearly satisfied for the family

$$\mathcal{H}_f := \{\Phi_t; t \geq 0\}.$$

Constructing the family  $\mathcal{S}$  requires much more geometric ingenuity.

**Example 2.52.** Suppose  $\mathcal{S}$  is the collection

$$\mathcal{S} = \left\{ \{x\}; x \in M \right\}.$$

The condition (b) is clearly satisfied, and in this case we have

$$c(\mathcal{H}_f, \mathcal{S}) = \min_{x \in M} f(x).$$

This is obviously a critical value of  $f$ .  $\square$



**Example 2.53 (Mountain-Pass points).** Suppose  $x_0$  is a strict local minimum of  $f$ , i.e., there exists a small, closed geodesic ball  $U$  centered at  $x_0 \in M$  such that

$$c_0 = f(x_0) < f(x), \quad \forall x \in U \setminus \{x_0\}.$$

Note that

$$c'_0 := \min_{x \in \partial U} f(x) > c_0.$$

Assume that there exists another point  $x_1 \in M \setminus U$  such that (see Figure 2.18)

$$c_1 = f(x_1) \leq f(x_0).$$

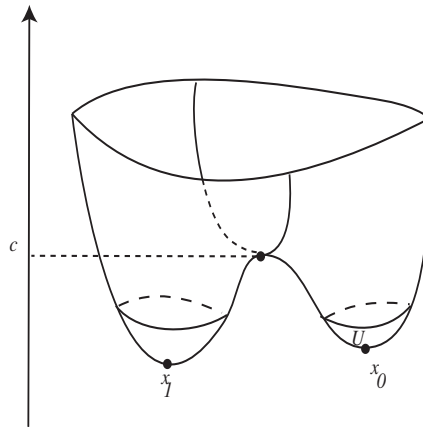

**Fig. 2.18.** A mountain pass from  $x_0$  to  $x_1$ .

Now denote by  $\mathcal{P}_{x_0}$  the collection of smooth paths  $\gamma : [0, 1] \rightarrow M$  such that

$$\gamma(0) = x_0, \quad \gamma(1) \in M^{c_0} \setminus U.$$

The collection  $\mathcal{P}_{x_0}$  is nonempty, since  $M$  is connected and  $x_1 \in M^{c_0} \setminus U$ . Observe that for any  $\gamma \in \mathcal{P}_{x_0}$  and any  $t \geq 0$  we have

$$\Phi_t \circ \gamma \in \mathcal{P}_{x_0}.$$

Now define

$$\mathcal{S} = \left\{ \gamma([0, 1]); \gamma \in \mathcal{P}_{x_0} \right\}.$$

Clearly the pair  $(\mathcal{H}_f, \mathcal{S})$  satisfies all the conditions in Definition 2.50, and we deduce that

$$c = \inf_{\gamma \in \mathcal{P}_{x_0}} \max_{s \in [0, 1]} f(\gamma(s))$$

is a critical value of  $f$  such that  $c \geq c'_0 > c_0$  (see Figure 2.18).

This statement is often referred to as the *Mountain-pass lemma* and critical points on the level set  $\{f = c\}$  are often referred to as *mountain-pass points*. Observe that the Mountain Pass Lemma implies that if a smooth function has two strict local minima then it must admit a third critical point.

The search strategy described in the Mountain-pass lemma is very intuitive if we think of  $f$  as a height function. The point  $x_0$  can be thought of as a depression and the boundary  $\partial U$  as a mountain range surrounding  $x_0$ . We look at all paths  $\gamma$  from  $x_0$  to points of lower altitude, and on each of them we pick a point  $x_\gamma$  of greatest height. Then we select the path  $\gamma$  such that the point  $x_\gamma$  has the smallest possible altitude.

It is perhaps instructive to give another explanation of why there should exist a critical value greater than  $c_0$ . Observe that the sublevel set  $M^{c_0}$  is disconnected while the manifold  $M$  is connected. The change in the topological type in going from  $M^{c_0}$  to  $M$  can be explained only by the presence of a critical value greater than  $c_0$ .  $\square$

To produce more sophisticated examples of min-max data we will use a technique pioneered by Lusternik and Schnirelmann. Denote by  $\mathcal{C}_M$  the collection of closed subsets of  $M$ . For a closed subset  $C \subset M$  and  $\varepsilon > 0$  we denote by  $N_\varepsilon(C)$  the open tube of radius  $\varepsilon$  around  $C$ , i.e., the set of points in  $M$  at distance  $< \varepsilon$  from  $C$ .

**Definition 2.54.** *An index theory on  $M$  is a map*

$$\gamma : \mathcal{C}_M \rightarrow \bar{\mathbb{Z}}_{\geq 0} := \{0, 1, \dots\} \cup \{\infty\}$$

*satisfying the following conditions.*

- **Normalization.** *For every  $x \in M$  there exists  $r = r(x) > 0$  such that*

$$\gamma(\{x\}) = 1 = \gamma(\overline{N_\varepsilon(x)}), \quad \forall x \in M, \quad \forall \varepsilon \in (0, r).$$

- **Topological invariance.** *If  $f : M \rightarrow M$  is a homeomorphism, then*

$$\gamma(C) = \gamma(f(C)), \quad \forall C \in \mathcal{C}_M.$$

- **Monotonicity.** *If  $C_0, C_1 \in \mathcal{C}_M$  and  $C_0 \subset C_1$ , then  $\gamma(C_0) \leq \gamma(C_1)$ .*
- **Subadditivity.**  $\gamma(C_0 \cup C_1) \leq \gamma(C_0) + \gamma(C_1)$ .

$\square$

Suppose we are given an index theory  $\gamma : \mathcal{C}_M \rightarrow \bar{\mathbb{Z}}_{\geq 0}$ . For every positive integer  $k$  we define

$$\Gamma_k := \left\{ C \in \mathcal{C}_M; \gamma(C) \geq k \right\}.$$

The axioms of an index theory imply that for each  $k$  the pair  $(\mathcal{H}_f, \Gamma_k)$  is a collection of min-max data. Hence, for every  $k$  the min-max value

$$c_k = \inf_{C \in \Gamma_k} \max_{x \in C} f(x)$$

is a critical value. Since

$$\Gamma_1 \supset \Gamma_2 \supset \dots,$$

we deduce that

$$c_1 \leq c_2 \leq \dots.$$

Observe that the decreasing family  $\Gamma_1 \supset \Gamma_2 \supset \dots$  stabilizes at  $\Gamma_m$ , where  $m = \gamma(M)$ . If by accident it happens that

$$c_1 < c_2 < \dots < c_{\gamma(M)},$$

then we could conclude that  $f$  has at least  $\gamma(M)$  critical points. We want to prove that this conclusion holds even if some of these critical values are equal.

**Theorem 2.55.** *Suppose that for some  $k, p > 0$  we have*

$$c_k = c_{k+1} = \dots = c_{k+p} = c,$$

*and denote by  $K_c$  the set of critical points on the level set  $c$ . Then either  $c$  is an isolated critical value of  $f$  and  $K_c$  contains at least  $p + 1$  critical points, or  $c$  is an accumulation point of  $\mathbf{Cr}_f$ , i.e., there exists a sequence of critical values  $d_n \neq c$  converging to  $c$ .*

*Proof.* Assume that  $c$  is an isolated critical value. We argue by contradiction. Suppose  $K_c$  contains at most  $p$  points. Then  $\gamma(K_c) \leq p$ . At this point we need a deformation result whose proof is postponed. Set

$$T_r(K_c) := \overline{N_r(K_c)}.$$

**Lemma 2.56 (Deformation lemma).** *Suppose  $c$  is an isolated critical value of  $f$  and  $K_c = \mathbf{Cr}_f \cap \{f = c\}$  is finite. Then for every  $\delta > 0$  there exist  $0 < \varepsilon, r < \delta$  and a homeomorphism  $h = h_{\delta, \varepsilon, r}$  of  $M$  such that*

$$h(\overline{M^{c+\varepsilon} \setminus T_r(K_c)}) \subset M^{c-\varepsilon}.$$

Consider  $\varepsilon, r$  sufficiently small as in the deformation lemma. Then the normalization and subadditivity axioms imply

$$\gamma(T_r(K_c)) \leq \gamma(K_c) = p.$$

We choose  $C \in \Gamma_{k+p}$  such that

$$\max_{x \in C} f(x) \leq c_{k+p} + \varepsilon = c + \varepsilon.$$

Note that

$$C \subset T_r(K_c) \cup \overline{C \setminus T_r(K_c)},$$

and from the subadditivity of the index we deduce

$$\gamma(\overline{C \setminus T_r(K_c)}) \geq \gamma(C) - \gamma(T_r(K_c)) \geq k.$$

Hence

$$\gamma(h(\overline{C \setminus T_r(K_c)})) = \gamma(\overline{C \setminus T_r(K_c)}) \geq k,$$

so that

$$C' := h(\overline{C \setminus T_r(K_c)}) \in \Gamma_k.$$

Since

$$\overline{C \setminus T_r(K_c)} \subset \overline{M^{c+\varepsilon} \setminus T_r(K_v)},$$

we deduce from the deformation lemma that

$$C' \subset M^{c-\varepsilon}.$$

Now observe that the condition  $C' \in \Gamma_k$  implies

$$c = c_k \leq \max_{x \in C'} f(x),$$

which is impossible since  $C' \subset M^{c-\varepsilon}$ .  $\square$

**Proof of the deformation lemma.** The strategy is a refinement of the proof of Theorem 2.6. The homeomorphism will be obtained via the flow determined by a carefully chosen gradient-like vector field.

Fix a Riemannian metric  $g$  on  $M$ . For  $r$  sufficiently small,  $N_r(K_c)$  is a finite disjoint union of open geodesic balls centered at the points of  $K_c$ . Let  $r_0 > 0$  such that  $N_{r_0}(K_c)$  is such a disjoint union and the only critical points of  $f$  in  $N_{r_0}(K_c)$  are the points in  $K_c$ . Fix  $\varepsilon_0$  such that  $c$  is the only critical value in the interval  $[c - \varepsilon_0, c + \varepsilon_0]$ . For  $r \in (0, r_0)$  define

$$b = b(r) := \inf \{ |\nabla f(x)|, x \in M^{c+\varepsilon_0} \setminus (M^{c-\varepsilon_0} \cup N_{r/8}(K_c)) \} > 0.$$

Choose  $\varepsilon = \varepsilon(r) \in (0, \varepsilon_0)$  satisfying

$$2\varepsilon < \min \left( \frac{b(r)r}{8}, b(r)^2, 1 \right) \implies \frac{2\varepsilon}{b(r)} < \frac{r}{8}, \quad \frac{2\varepsilon}{\min(1, b(r)^2)} \leq 1. \quad (2.20)$$

Define smooth cutoff functions

$$\alpha : M \rightarrow [0, 1], \quad \beta : M \rightarrow [0, 1]$$

such that

- $\alpha(x) = 0$  if  $|f(x) - c| \geq \varepsilon_0$  and  $\alpha(x) = 1$  if  $|f(x) - c| \leq \varepsilon$ ;
- $\beta(x) = 1$  if  $\text{dist}(x, K_c) \geq r/4$  and  $\beta(x) = 0$  if  $\text{dist}(x, K_c) < r/8$ .

Finally, define a rescaling function

$$\varphi : [0, \infty) \rightarrow [0, \infty), \quad \varphi(s) := \begin{cases} 1 & s \in [0, 1], \\ s^{-1} & s \geq 1. \end{cases}$$

We can now construct the vector field  $\xi$  on  $M$  by setting

$$\xi(x) := -\alpha \cdot \beta \cdot \varphi(|\nabla^g f|^2) \nabla^g f.$$

Observe that  $\xi$  vanishes outside the region  $\{c - \varepsilon_0 < f < c + \varepsilon_0\}$  and also vanishes in an  $r/8$ -neighborhood of  $K_c$ . This vector field is not smooth, but it still is Lipschitz continuous. Note also that

$$|\xi(x)| \leq 1, \quad \forall x \in M.$$

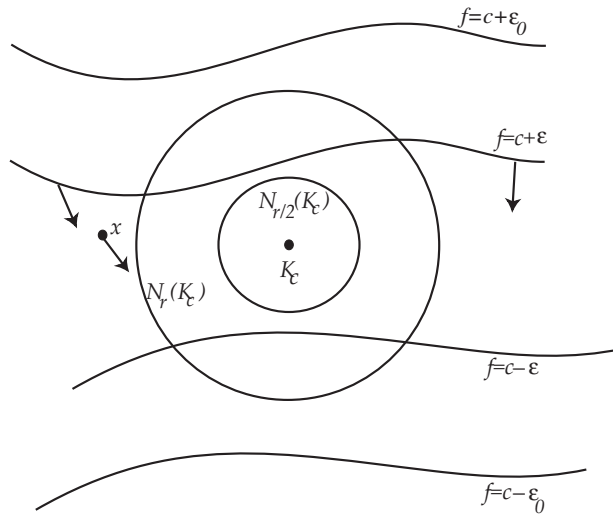

**Fig. 2.19.** A gradient-like flow.

The existence theorem for ODEs shows that for every  $x \in M$  there exist  $T_{\pm}(x) \in (0, \infty]$  and a  $C^1$ -integral curve  $\gamma_x : (-T_-(x), T_+(x)) \rightarrow M$  of  $\xi$  through  $x$ ,

$$\gamma_x(0) = x, \quad \dot{\gamma}_x(t) = \xi(\gamma_x(t)), \quad \forall t \in (-T_-(x), T_+(x)).$$

The compactness of  $M$  implies that the integral curves of  $\xi$  are defined for all  $t \in \mathbb{R}$ , i.e.,  $T_{\pm}(x) = \infty$ . In particular, we obtain a (topological) flow  $\Phi_t$  on  $M$ . To prove the deformation lemma it suffices to show that

$$\Phi_1(M^{c+\varepsilon} \setminus N_r(K_c)) \subset M^{c-\varepsilon}.$$

Note that by construction we have

$$\frac{d}{dt} f(\Phi_t(x)) \leq 0, \quad \forall x \in M,$$

so that

$$\Phi_1(M^{c-\varepsilon}) \subset M^{c-\varepsilon}.$$

Let  $x \in M^{c+\varepsilon} \setminus (N_r(K_c) \cup M^{c-\varepsilon})$ . We need to show that  $\Phi_1(x) \in M^{c-\varepsilon}$ . We will achieve this in several steps.

For simplicity we set  $x_t := \Phi_t(x)$ . Consider the region

$$Z = \{c - \varepsilon \leq f \leq c + \varepsilon\} \setminus N_{r/2}(K_c),$$

and define

$$\mathcal{T}_x := \{t \geq 0; x_s \in Z, \forall s \in [0, t]\}.$$

Clearly  $\mathcal{T}_x \neq \emptyset$ .

**Step 1.** *We will prove that if  $t \in \mathcal{T}_x$ , then*

$$\text{dist}(x, x_s) < \frac{r}{8}, \quad \forall s \in [0, t].$$

In other words, during the time interval  $\mathcal{T}_x$  the flow line  $t \mapsto x_t$  cannot stray too far from its initial point.

Observe that  $\alpha$  and  $\beta$  are equal to 1 in the region  $Z$  and thus for every  $t \in \mathcal{T}_x$  we have

$$\begin{aligned} 2\varepsilon &\geq f(x) - f(x_t) = - \int_0^t g(\nabla f(x_s), \xi(x_s)) ds \\ &= \int_0^t |\nabla f(x_s)|^2 \varphi(|\nabla f(x_s)|^2) ds \\ &\geq b(r) \int_0^t |\nabla f(x_s)| \varphi(|\nabla f(x_s)|^2) ds = b(r) \int_0^t \left| \frac{dx_s}{ds} \right| ds \\ &\geq b(r) \cdot \text{dist}(x, x_t). \end{aligned}$$

From (2.20) we deduce

$$\text{dist}(x, x_t) \leq \frac{2\varepsilon}{b(r)} < \frac{r}{8}.$$

**Step 2.** *We will prove that there exists  $t > 0$  such that  $\Phi_t(x) \in M^{c-\varepsilon}$ . Loosely speaking, we want to show that there exists a moment of time  $t$  when the energy  $f(x_t)$  drops below  $c - \varepsilon$ . Below this level the rate of decrease in the energy  $f$  will pickup.*

We argue by contradiction, and thus we assume  $f(x_t) > c - \varepsilon, \forall t > 0$ . Thus

$$0 \leq f(x) - f(x_t) \leq 2\varepsilon, \quad \forall t > 0.$$

Since  $x_s \in \{c - \varepsilon \leq f \leq c + \varepsilon\}, \forall s \geq 0$ , we deduce

$$\mathcal{T}_x = \left\{ t \geq 0; \text{dist}(x_s, K_c) \geq \frac{r}{2}, \forall s \in [0, t] \right\}.$$

Hence

$$\text{dist}(x_t, K_c) \geq \text{dist}(x, K_c) - d(x, x_t) > r - \frac{r}{8}, \quad \forall t \in \mathcal{J}_x$$

This implies that  $T = \sup \mathcal{J}_x = \infty$ . Indeed, if  $T < \infty$  then

$$\begin{aligned} \text{dist}(x_T, K_c) &\geq r - \frac{r}{8} > \frac{r}{2} \\ \implies \text{dist}(x_t, K_c) &> \frac{r}{2}, \quad \forall t \text{ sufficiently close to } T. \end{aligned}$$

This contradicts the maximality of  $T$ . We deduce

$$x_t \in Z \iff c - \varepsilon < f(x_t) \leq c + \varepsilon, \quad \text{dist}(x_t, K_c) > \frac{r}{2}, \quad \forall t \geq 0.$$

This is impossible, since there exists a positive constant  $\nu$  such that

$$|\xi(x)| > \nu, \quad \forall x \in Z,$$

which implies that

$$\frac{df(x_t)}{dt} \leq -b(r)\nu \implies \lim_{t \rightarrow \infty} f(x_t) = -\infty,$$

which is incompatible with the condition  $0 \leq f(x) - f(x_t) \leq 2\varepsilon$  for every  $t \geq 0$ .

**Step 3.** We will prove that  $\Phi_1(x) \in M^{c-\varepsilon}$  by showing that there exists  $t \in (0, 1]$  such that  $x_t \in M^{c-\varepsilon}$ . Let

$$t_0 := \inf\{t \geq 0; x_t \in M^{c-\varepsilon}\}.$$

From Step 2 we see that  $t_0$  is well defined and  $f(x_{t_0}) = c - \varepsilon$ . We claim that the path

$$[0, t_0] \ni s \mapsto x_s$$

does not intersect the neighborhood  $N_{r/2}(K_c)$ , i.e.,

$$\text{dist}(x_s, K_c) \geq \frac{r}{2}, \quad \forall s \in [0, t_0].$$

Indeed, from Step 1 we deduce

$$\text{dist}(x_s, K_c) > r - \frac{r}{8}, \quad \forall s \in [0, t_0].$$

Now observe that

$$\frac{df(x_s)}{ds} = -|\nabla f|^2 \varphi(|\nabla f|^2) \geq -\max(1, b(r)^2).$$

Thus, for every  $s \in [0, t_0]$  we have

$$f(x) - f(x_s) \geq s \max(1, b(r)^2) \implies f(x_s) \leq c + \varepsilon - s \max(1, b(r)^2).$$

If we let  $s = t_0$  in the above inequality and use the equality  $f(x_{t_0}) = c - \varepsilon$ , we deduce

$$c - \varepsilon \leq c + \varepsilon - t_0 \max(1, b(r)^2) \implies t_0 \leq \frac{2\varepsilon}{\max(1, b(r)^2)} \stackrel{(2.20)}{\leq} 1.$$

This completes the proof of the deformation lemma.  $\square$

We now have the following consequence of Theorem 2.55.

**Corollary 2.57.** *Suppose  $\gamma : \mathcal{C}_M \rightarrow \bar{\mathbb{Z}}_{\geq 0}$  is an index theory on  $M$ . Then any smooth function on  $M$  has at least  $\gamma(M)$  critical points.*  $\square$

To complete the story we need to produce interesting index theories on  $M$ . It turns out that the Lusternik–Schnirelmann category of a space is such a theory.

**Definition 2.58.** (a) *A subset  $S \subset M$  is said to be contractible in  $M$  if the inclusion map  $S \hookrightarrow M$  is homotopic to the constant map.*

(b) *For every closed subset  $C \subset M$  we define its Lusternik–Schnirelmann category of  $C$  in  $M$  and denote it by  $\text{cat}_M(C)$ , to be the smallest positive integer  $k$  such that there exists a cover of  $C$  by closed subsets*

$$S_1, \dots, S_k \subset M$$

*that are contractible in  $M$ . If such a cover does not exist, we set*

$$\text{cat}_M(C) := \infty. \quad \square$$

**Theorem 2.59 (Lusternik–Schnirelmann).** *If  $M$  is a compact smooth manifold, then the correspondence*

$$\mathcal{C}_M \ni C \mapsto \text{cat}_M(C)$$

*defines an index theory on  $M$ . Moreover, if  $R$  denotes one of the rings  $\mathbb{Z}/2, \mathbb{Z}, \mathbb{Q}$  then*

$$\text{cat}(M) := \text{cat}_M(M) \geq \text{CL}(M, R) + 1,$$

*where  $\text{CL}(M, R)$  denotes the cuplength of  $M$  with coefficients in  $R$ , i.e., the largest integer  $k$  such that there exists*

$$\alpha_1, \dots, \alpha_k \in H^\bullet(M, R)$$

*with the property that*

$$\prod_{j=1}^k \deg \alpha_j \neq 0, \quad \alpha_1 \cup \dots \cup \alpha_k \neq 0.$$



*Proof.* It is very easy to check that  $\text{cat}_M$  satisfies all the axioms of an index theory: normalization, topological invariance, monotonicity, and subadditivity, and we leave this task to the reader. The lower estimate of  $\text{cat}(M)$  requires a bit more work. We argue by contradiction. Let

$$\ell := \text{CL}(M, R)$$

and assume that  $\text{cat}(M) \leq \ell$ . Then there exist  $\alpha_1, \dots, \alpha_\ell \in H^\bullet(M, R)$  and closed sets  $S_1, \dots, S_\ell \subset M$ , contractible in  $M$ , such that

$$M = \bigcup_{k=1}^{\ell} S_k, \quad \alpha_1 \cup \dots \cup \alpha_\ell \neq 0, \quad \prod_{j=1}^k \deg \alpha_j \neq 0.$$

Denote by  $j_k$  the inclusion  $S_k \hookrightarrow M$ .

Since  $S_k$  is contractible in  $M$ , we deduce that the induced map

$$j_k^* : H^\bullet(M, R) \rightarrow H^\bullet(S_k, R)$$

is trivial. In particular, the long exact sequence of the pair  $(M, S_k)$  shows that the natural map

$$i_k : H^\bullet(M, S_k; R) \rightarrow H^\bullet(M)$$

is onto. Hence there exists  $\beta_k \in H^\bullet(M, S_k)$  such that

$$i_k(\beta_k) = \alpha_k.$$

Now we would like to take the cup products of the classes  $\beta_k$ , but we hit a technical snag. The cup product in *singular* cohomology,

$$H^\bullet(M, S_i; R) \times H^\bullet(M, S_j; R) \rightarrow H^\bullet(M, S_i \cup S_j; R),$$

is defined only if the sets  $S_i, S_j$  are “reasonably well behaved” (“excisive” in the terminology of [Spa, Section 5.6]). Unfortunately, we cannot assume this. There are two ways out of this technical conundrum. Either we modify the definition of  $\text{cat}_M$  to allow only covers by closed, contractible, and *excisive* sets, or we work with a more supple concept of cohomology. We adopt this second option and we choose to work with Alexander cohomology  $\bar{H}^\bullet(-, R)$ , [Spa, Section 6.4].

This cohomology theory agrees with the singular cohomology for spaces which are not too “wild”. In particular, we have an isomorphism  $\bar{H}^\bullet(M, R) \cong H^\bullet(M, R)$ , and thus we can think of the  $\alpha_k$ ’s as Alexander cohomology classes.

Arguing exactly as above, we can find classes  $\beta_k \in \bar{H}^\bullet(M, S_k; R)$  such that

$$i_k(\beta_k) = \alpha_k.$$

In Alexander cohomology there is a cup product

$$\cup : \bar{H}^\bullet(M, A; R) \times \bar{H}^\bullet(M, B; R) \rightarrow \bar{H}^\bullet(M, A \cup B; R),$$

well defined for *any* closed subsets  $A, B$  of  $M$ . In particular, we obtain a class

$$\beta_1 \cup \cdots \cup \beta_\ell \in \bar{H}^\bullet(M, S_1 \cup \cdots \cup S_\ell; R)$$

that maps to  $\alpha_1 \cup \cdots \cup \alpha_\ell$  via the natural morphism

$$\bar{H}^\bullet(M, S_1 \cup \cdots \cup S_\ell; R) \rightarrow \bar{H}^\bullet(M, R).$$

Now observe that  $\hat{H}^\bullet(M, S_1 \cup \cdots \cup S_\ell; R) = 0$ , since  $S_1 \cup \cdots \cup S_\ell = M$ . We reached a contradiction since  $\alpha_1 \cup \cdots \cup \alpha_\ell \neq 0$ .  $\square$

**Example 2.60.** Since  $\text{CL}(\mathbb{R}\mathbb{P}^n, \mathbb{Z}/2) = \text{CL}((S^1)^n, \mathbb{Z}) = \text{CL}(\mathbb{C}\mathbb{P}^n, \mathbb{Z}) = n$  we deduce

$$\text{cat}(\mathbb{R}\mathbb{P}^n) \geq n + 1, \quad \text{cat}((S^1)^n) \geq n + 1, \quad \text{cat}(\mathbb{C}\mathbb{P}^n) \geq n + 1.$$

$\square$

**Corollary 2.61.** *Every even smooth function  $f : S^n \rightarrow \mathbb{R}$  has at least  $2(n+1)$  critical points.*

*Proof.* Observe that  $f$  descends to a smooth function  $\bar{f}$  on  $\mathbb{R}\mathbb{P}^n$  which has at least  $\text{cat}(\mathbb{R}\mathbb{P}^n) \geq n + 1$  critical points. Every critical point of  $\bar{f}$  is covered by precisely two critical points of  $f$ .  $\square$

---

## Applications

It is now time to reap the benefits of the theoretical work we sowed in the previous chapter. Most applications of Morse theory that we are aware of share one thing in common. More precisely, they rely substantially on the special geometric features of a concrete situation to produce an interesting Morse function, and then squeeze as much information as possible from geometrical data. Often this process requires deep and rather subtle incursions into the differential geometry of the situation at hand. The end result will display surprising local-to-global interactions.

The applications we have chosen to present follow this pattern and will lead us into unexpected geometrical places that continue to be at the center of current research.

### 3.1 The Moduli Space of Planar Polygons

We want to investigate in greater detail the robotics problem discussed in Example 1.5, 1.10 and 2.11. More precisely, consider a robot arm with arm lengths  $r_1, \dots, r_n$ , where the initial joint  $J_0$  is fixed at the origin. As explained in Example 1.5 a position of the robot arm is indicated by a collection angles  $\theta = (\theta_1, \dots, \theta_n) \in (S^1)^n$ , so that the location of the  $k$ -th joint is

$$J_k = \sum_{i=1}^k r_i e^{i\theta_i}.$$

We will refer to the vector  $\mathbf{r} = (r_1, \dots, r_n) \in \mathbb{R}_{>0}^n$  as the *length vector* of the robot arm.

We declare two positions or configurations of the robot arm to be *equivalent* if one can be obtained from the other by a rotation of the plane about the origin. More formally, two configurations

$$\theta = (\theta_1, \dots, \theta_n), \quad \phi = (\phi_1, \dots, \phi_n)$$

are equivalent if there exists an angle  $\omega \in [0, 2\pi)$  such that

$$\phi_k - \theta_k = \omega \pmod{2\pi}, \quad \forall k = 1, \dots, n.$$

We denote by  $[\theta_1, \dots, \theta_n]$  the equivalence class of the configuration  $(\theta_1, \dots, \theta_n)$  and by  $W_n = W_n(\mathbf{r})$  the space of equivalence classes of configurations. Following [Fa] we will refer to  $W_n$  as the *work space* of the robot arm. We denote by  $W_n^*$  the set of equivalence classes of configurations such that  $J_n \neq J_0$ , and by  $\mathcal{M}_{\mathbf{r}}$  the set of equivalence classes of configurations such that  $J_n = J_0$ . Note that  $\mathcal{M}_{\mathbf{r}}$  is non-empty if and only if

$$r_i \leq \sum_{j \neq i} r_j, \quad \forall i = 1, \dots, n.$$

The work space  $W_n$  is a quotient space of the  $n$ -torus and as such it has an induced quotient topology. In particular, we can equip  $\mathcal{M}_{\mathbf{r}}$  with a topology as a closed subspace of  $W_n$ .

Note that any configuration of the robot arm such that  $J_n \neq J_0 = 0$  is equivalent to a unique configuration such that  $J_n$  lies in on the positive side of the  $x$ -axis. This shows that the configuration space  $C_n$  discussed in Example 1.5 can be identified with  $W_n^*$ .

A configuration such that  $J_n = J_0$  is uniquely determined by requiring that the joint  $J_{n-1}$  lies on the positive part of the  $x$ -axis at a distance  $r_n$  from the origin. Observe that the configurations in  $\mathcal{M}_{\mathbf{r}}$  can be identified with  $n$ -gons whose side lengths  $r_1, \dots, r_n$ . For this reason, the topological space  $\mathcal{M}_{\mathbf{r}}$  is called the *moduli space of planar polygons with length vector  $\mathbf{r}$* . In this section we want show how clever Morse theoretic techniques lead to a rather explicit description of the homology of  $\mathcal{M}_{\mathbf{r}}$ . All the results in this section are due to M. Farber and D. Schütz [FaSch].

**Proposition 3.1.** *The work space  $W_n$  is homeomorphic to a  $(n-1)$ -torus.*

*Proof.* Consider the diagonal action of  $S^1$  on  $T^n = (S^1)^n$  given by

$$e^{i\omega} \cdot (e^{i\theta_1}, \dots, e^{i\theta_n}) := (e^{i(\theta_1+\omega)}, \dots, e^{i(\theta_n+\omega)}).$$

The natural map

$$(S^1)^n \ni (e^{i\theta_1}, \dots, e^{i\theta_n}) \xrightarrow{\mathbf{q}} [\theta_1, \dots, \theta_n] \in W_n$$

is invariant with respect to this action and the induced map  $(S^1)^n/S^1 \rightarrow W_n$  is a homeomorphism. On the other hand, the map

$$(S^1)^n \ni (e^{i\theta_1}, \dots, e^{i\theta_n}) \xrightarrow{\Psi} (e^{i(\theta_2-\theta_1)}, \dots, e^{i(\theta_n-\theta_1)}) \in (S^1)^{n-1}$$

is also invariant under the above action of  $S^1$  and induces a homeomorphism  $(S^1)^n/S^1 \rightarrow T^{n-1}$ . □

For any permutation  $\sigma$  of  $\{1, \dots, n\}$  and any length vector  $\mathbf{r} = (r_1, \dots, r_n)$  we set  $\sigma\mathbf{r} := (r_{\sigma(1)}, \dots, r_{\sigma(n)})$ . Note that we have a homeomorphism

$$W_n(\mathbf{r}) \ni [\theta_1, \dots, \theta_n] \mapsto [\theta_{\sigma(1)}, \dots, \theta_{\sigma(n)}] \in W_n(\sigma\mathbf{r})$$

that maps  $\mathcal{M}_{\mathbf{r}}$  homeomorphically onto  $\mathcal{M}_{\sigma\mathbf{r}}$ . Thus, in order to understand the topology of  $\mathcal{M}_{\mathbf{r}}$  we can assume that  $\mathbf{r}$  is *ordered*, i.e.,

$$r_1 \geq r_2 \geq \dots \geq r_n > 0.$$

The computations in Example 1.5 allow us to extract some information about  $\mathcal{M}_{\mathbf{r}}$ , where  $\mathbf{r} = (r_1, \dots, r_n)$  is ordered. We will also assume that the genericity assumption (1.1) is satisfied, i.e.,

$$\sum_{k=1}^n \epsilon_k r_k \neq 0, \quad \forall \epsilon_1, \dots, \epsilon_n \in \{1, -1\}.$$

Consider the a robot arm with  $(n - 1)$ -segments of lengths  $r_1, \dots, r_{n-1}$  and consider again the set  $C_{n-1}$  of all configurations of this robot arm such that  $J_0$  is fixed at the origin while the endpoint  $J_{n-1}$  lies on the positive part of the positive  $x$ -axis.

We have a smooth function  $h_{n-1} : C_{n-1} \rightarrow (0, \infty)$  that associates to a configuration the location of the joint  $J_{n-1}$  on the  $x$ -axis. Observe that  $\mathcal{M}_{\mathbf{r}}$  can be identified with the level set  $\{h_{n-1} = r_n\}$ .

The genericity assumption implies that  $r_n$  is a *regular* value of  $h$ . The manifold  $C_{n-1}$  has dimension  $(n - 2)$  so that the level set  $\{h_{n-1} = r_n\}$  is a smooth manifold of dimension  $(n - 3)$ . We have thus established the following result.

**Proposition 3.2.** *If the length vector  $\mathbf{r}$  satisfies the genericity assumption (1.1) then the moduli space  $\mathcal{M}_{\mathbf{r}}$  is homeomorphic to a smooth manifold of dimension  $(n - 3)$ .  $\square$*

Fix an ordered length vector  $\mathbf{r} = (r_1, \dots, r_n)$  satisfying (1.1). For any subset  $I \subset \{1, \dots, n\}$  we set

$$\mathbf{r}(I) := \sum_{i \in I} r_i - \sum_{j \notin I} r_j.$$

The subset  $I$  is called  *$\mathbf{r}$ -short* (or short if  $\mathbf{r}$  is understood from the context) if  $\mathbf{r}(I) < 0$ . A subset is called *long* if  $\mathbf{r}(I) > 0$ . Due to the genericity assumption we see that  $\mathbf{r}(I) \neq 0$  for any subset  $I$ , so that  $I$  is either long, or short. Moreover, a set is long/short if and only if its complement is short/long. We denote by  $\mathcal{L}_{\mathbf{r}}^{\pm}$  the collection of  $\mathbf{r}$ -long/short subsets. For any  $k = 0, 1, \dots, n-3$  we denote by  $a_k = a_k(\mathbf{r})$  the number of  $\mathbf{r}$ -short subsets of cardinality  $k + 1$  that contain 1, i.e.,

$$a_k(\mathbf{r}) := \#\{I \in \mathcal{L}_{\mathbf{r}}^-; 1 \in I, \#I = k + 1\}.$$

We have the following result.

**Theorem 3.3 (Farber-Schütz).** *Suppose  $\mathbf{r} = (r_1, \dots, r_n)$  is an ordered length vector satisfying the genericity assumption (1.1). Then, for any  $k = 0, 1, \dots, n-3$  we have the equality*

$$\dim H_k(\mathcal{M}_{\mathbf{r}}, \mathbb{Q}) = a_k(\mathbf{r}) + a_{n-3-k}(\mathbf{r}).$$

*Proof.* Let us briefly outline the strategy which at its core is based on a detailed analysis of a Morse function on  $W_n$ . The work space  $W_n$  is equipped with a natural continuous function

$$h_n : W_n \rightarrow [0, \infty)$$

that associates to every equivalence class of configurations the distance from  $J_0$  to  $J_n$ . This is not a smooth function but its restriction to  $W_n^*$  is a smooth function that we have encountered before in Example 1.5 and 1.10. Namely, if we identify  $W_n^*$  with the space  $C_n$  of configurations of the robot arm such that the endpoint  $J_n$  lies on the positive side of the  $x$ -axis, then  $h_n$  associates to such a configuration the location of  $J_n$  on the  $x$ -axis. Using  $h_n$  we can construct the smooth function  $f = f_{\mathbf{r}} : W_n \rightarrow (-\infty, 0]$

$$f(\boldsymbol{\theta}) = -h_n(\boldsymbol{\theta})^2 = -\left| \sum_{k=1}^n r_k e^{i\theta_k} \right|^2 = -\text{dist}(J_0, J_n)^2.$$

Observe that  $\mathcal{M}_{\mathbf{r}}$  coincides with the top level set  $\{f = 0\}$ . Define

$$N_\varepsilon := \{f \geq -\varepsilon\}, \quad \varepsilon > 0.$$

If  $\varepsilon$  is sufficiently small, then the space  $\mathcal{M}_{\mathbf{r}}$  is homotopy equivalent to its neighborhood  $N_\varepsilon$ . Hence it suffices to understand the (co)homology of  $N_\varepsilon$ . For simplicity we will denote by  $H_\bullet(X)$  the homology of  $X$  with integral coefficients.

On the other hand,  $N_\varepsilon$  is an oriented  $(n-1)$ -dimensional manifold with boundary, and the Poincaré-Lefschetz duality implies that for any  $j = 0, \dots, n-1$  we have isomorphisms

$$H^j(N_\varepsilon) \cong H_{n-1-j}(N_\varepsilon, \partial N_\varepsilon), \quad H_j(N_\varepsilon) \cong H^{n-1-j}(N_\varepsilon, \partial N_\varepsilon).$$

Thus it suffices to understand the (co)homology of the pair  $(N_\varepsilon, \partial N_\varepsilon)$ .

From the excision isomorphism we see that this is isomorphic to the (co)homology of the pair  $(W, W^{-\varepsilon})$  where  $W = W_n$ ,  $W^{-\varepsilon} = \{f \leq -\varepsilon\}$ . We will determine the cohomology of the pair  $(W, W^{-\varepsilon})$  in two steps.

- A. Produce a description of the homology of  $W^{-\varepsilon}$  using the Morse function  $f$ .
- B. Obtain detailed information about the morphisms entering into the long exact sequence of the pair  $(W, W^{-\varepsilon})$ .

**Lemma 3.4.** *The restriction of  $f$  to  $W^* = \{f \neq 0\}$  is a Morse function, and there exists a natural bijection between the set of critical points of  $f$  on  $W^*$  and the collection of long  $\mathbf{r}$ -sets. Moreover, if  $I$  is such a long set, then the Morse index of the corresponding critical point is  $n - \#I$ .*

*Proof.* As we have explained before, the open set  $W^* = W_n^*$  can be identified with the configuration space  $C_n$  in Example 1.5. For simplicity we write  $h$  instead of  $h_n$ . The function  $f = -h^2$  is not equal to zero on this set so it must have the same critical points of  $h$ . We know that these points correspond to collinear configurations,  $\theta_k = 0, \pi$ , such that the last joint is located on the positive part of the  $x$ -axis. For such configurations we set  $\epsilon_k := e^{i\theta_k}$  and we deduce  $\epsilon_k = \pm 1, \forall k$  and

$$\sum_{k=1}^n \epsilon_k r_k > 0.$$

We see that there exists a bijection between long subsets of  $\{1, \dots, n\}$  and the critical points of  $f$  on  $W^*$ . For such a collinear configuration the corresponding long set is

$$\{k; \epsilon_k > 0\}.$$

For any long set  $I$  we denote by  $\theta_I$  the corresponding critical configuration, and we denote by  $c_I$  the corresponding critical value,  $c_I := f(\theta_I)$

Denote by  $H_I$  the Hessian of  $f$  at  $\theta_I$ . Then, for any  $X, Y \in T_{\theta_I}W$  we have

$$H_I(X, Y) = -\hat{X}\hat{Y}h^2(\theta_I),$$

where  $\hat{X}, \hat{Y}$  are smooth vector fields on  $W$  such that  $\hat{X}(\theta_I) = X, \hat{Y}(\theta_I) = Y$ . We have

$$\hat{Y}h^2 = 2h\hat{Y}h \text{ and } \hat{X}\hat{Y}h^2 = 2(\hat{X}h)(\hat{Y}h) - 2h\hat{X}\hat{Y}h.$$

The function  $(\hat{X}h)(\hat{Y}h)$  vanishes at  $\theta_I$  and we deduce

$$H_I = -2hH_{h, \theta_I}.$$

Since the function  $h$  is positive we deduce that  $H_I$  is nondegenerate. Denote by  $\lambda_I$  the Morse index of  $f$  at  $\theta_I$ . The computations in Example 1.10 show that

$$\lambda_I = \dim W - \lambda(h, \theta_I) \stackrel{(1.4)}{=} n - \#\{k; \epsilon_k = 1\} = n - \#I. \quad \square$$

For every subset  $I \subset \{1, \dots, n\}$  we set

$$W_I := \{[\theta_1, \dots, \theta_n] \in W; \theta_{i_1} = \theta_{i_2}, \forall i_1, i_2 \in I\}.$$

Observe that  $W_I$  is a torus of dimension  $n - \#I$ . In particular, when  $I$  is a long subset we have

$$\theta_I \in W_I, \quad \dim W_I = \lambda_I.$$

We have the following key result.

**Lemma 3.5.** *Suppose  $I$  is a  $\mathbf{r}$ -long subset. Then the restriction of  $f$  to  $W_I$  is a Morse function that achieves its absolute maximum at  $\theta_I$ .  $\square$*

To keep the flow of arguments uninterrupted we will present the proof of this lemma after we have completed the proof of Theorem 3.3. For  $t \in \mathbb{R}$  we set

$$W^t := \{f \leq t\}.$$

For every critical value  $c < 0$  of  $f$  we define

$$\mathcal{L}_{\mathbf{r}}^+(c) := \{I \in \mathcal{L}_{\mathbf{r}}^+; c_I = c\}.$$

In other words,  $\mathcal{L}_{\mathbf{r}}^+(c)$  can be identified with the set of critical points of  $f$  on the level set  $\{f = c\}$ . Lemma 3.5 implies that for any  $I \in \mathcal{L}_{\mathbf{r}}^+(c)$  the following hold.

- The torus  $W_I$  is contained in the sublevel set  $W^c$  and intersects the level set  $\{f = c\}$  only at the point  $\theta_I$ .
- For  $\varepsilon > 0$  sufficiently small, the torus  $W_I$  intersects the level set  $\{f = c - \varepsilon\}$  transversally, and  $W_I^\varepsilon := W_I \cap \{c - \varepsilon \leq f \leq c\}$  is a diffeomorphic to a disk of dimension  $\lambda_I$ . We fix an orientation  $\mu_I$  on  $W_I$  so that we get a relative homology class,

$$u_I(\varepsilon) := [W_I^\varepsilon, \partial W_I^\varepsilon, \mu_I] \in H_{\lambda_I}(W^{c+\varepsilon}, W^{c-\varepsilon}),$$

and a homology class

$$w_I(\varepsilon) = [W_I, \mu_I] \in H_{\lambda_I}(W^{c+\varepsilon}).$$

**Lemma 3.6.** *Let  $c$  be a critical value of  $f$ ,  $c < 0$ . Then for  $\varepsilon > 0$  sufficiently small the following hold.*

- (a) *The collection  $\{u_I(\varepsilon); I \in \mathcal{L}_{\mathbf{r}}^+(c)\}$  forms an integral basis of the relative homology  $H_{\bullet}(W^{c+\varepsilon}, W^{c-\varepsilon})$ .*
- (b) *If*

$$i_* : H_{\bullet}(W^{c+\varepsilon}) \rightarrow H_{\bullet}(W^{c+\varepsilon}, W^{c-\varepsilon})$$

*denotes the inclusion induced morphism and*

$$\partial : H_{\bullet}(W^{c+\varepsilon}, W^{c-\varepsilon}) \rightarrow H_{\bullet-1}(W^{c-\varepsilon})$$

*denotes the connecting morphism in the long exact sequence of the pair  $(W^{c+\varepsilon}, W^{c-\varepsilon})$ , then*

$$i_*(w_I) = u_I, \quad \partial u_I = 0, \quad \forall I \in \mathcal{L}_{\mathbf{r}}^+(c).$$

*Proof.* (a) We choose a Riemann metric  $g$  on  $W$  with the following property: for any critical point  $\theta_I \in \{f = c\}$  there exist local coordinates  $(x^1, \dots, x^{n-1})$  in a neighborhood  $\mathcal{N}_I$  of  $\theta_I$  such that the following hold.



- $x^k(\boldsymbol{\theta}_I) = 0, \forall k$ .
- $g = (dx^1)^2 + \dots + (dx^{n-1})^2$  on  $\mathcal{N}_I$ .
- $f = c - \sum_{j=1}^{\lambda_I} (x^j)^2 + \sum_{k>\lambda_I} (x^k)^2$  on  $\mathcal{N}_I$ .
- The tangent space  $T_{\boldsymbol{\theta}_I} W_I \subset T_{\boldsymbol{\theta}_I} W$  coincides with the coordinate plane  $\mathcal{P}_I$  spanned by the tangent vector  $\partial_{x^j}, 1 \leq j \leq \lambda_I$ .

Let  $\xi$  denote the vector field  $-\nabla^g f$ . Denote by  $\mathcal{W}_I^-$  the unstable manifold of  $\boldsymbol{\theta}_I$  with respect to  $\xi$ . Note that  $\mathcal{W}_I^- \cap \mathcal{N}_I$  can be identified with an open neighborhood  $\mathcal{O}_I$  of 0 in the plane  $\mathcal{P}_I$ , and thus  $\mathcal{W}_I^-$  has a natural orientation induced from the orientation of  $\mathcal{P}_I$ .

For  $\varepsilon > 0$  sufficiently small the intersection

$$\mathcal{W}_I(\varepsilon) := \mathcal{W}_I^- \cap \{c - \varepsilon \leq f \leq c + \varepsilon\}$$

is a  $\lambda_I$  dimensional oriented disk, the unstable disk as constructed in Section 2.5. We get a homology class

$$v_I(\varepsilon) = [\mathcal{W}_I^-(\varepsilon), \partial \mathcal{W}_I^-(\varepsilon), \mu_I] \in H_{\lambda_I}(W^{c+\varepsilon, c-\varepsilon}).$$

Arguing as in Section 2.5 we see that for  $\varepsilon > 0$  sufficiently small the collection  $\{u_I(\varepsilon); I \in \mathcal{L}_r^+(c)\}$  is an integral basis of  $H_\bullet(W^{c+\varepsilon, c-\varepsilon}; \mathbb{Z})$ . The class  $v_I(\varepsilon)$  is none other than the class  $\langle \boldsymbol{\theta}_I \rangle$  as defined in Section 2.5.

To prove (a) it suffices to show that  $u_I(\varepsilon) = v_I(\varepsilon)$  for  $\varepsilon$  sufficiently small. Given our local coordinates, we can identify  $\mathcal{N}_I$  with some open convex neighborhood of 0 in the tangent space  $\mathcal{P} := T_{\boldsymbol{\theta}_I} W$ . Under this identification  $\boldsymbol{\theta}_I$  corresponds to the origin. We let  $y$  denote the vectors in  $\mathcal{P}_I$  and  $z$  denote the vectors in  $\mathcal{P}_I^\perp$  so that any  $x \in \mathcal{N}_I \subset \mathcal{P}$  admits a unique orthogonal decomposition  $x = y + z$ . In this notation we have

$$f(y, z) = -|y|^2 + |z|^2.$$

Since  $W_I$  is tangent to  $\mathcal{P}_I$  we can find an even smaller neighborhood  $\mathcal{N}'_I$  of the origin in  $\mathcal{P}$  such that the portion  $W_I \cap \mathcal{N}'_I$  can be described as the graph of a smooth map

$$\phi : B_I \subset \mathcal{P}_I \rightarrow \mathcal{P}_I^\perp,$$

where  $B_I \subset \mathcal{O}_I$  is a tinny open ball of radius  $r_0$  on  $\mathcal{P}_I$  centered at 0, and the differential of  $\phi$  at 0 is trivial. In other words

$$W_I \cap \mathcal{N}'_I = \{x = y + z; |y| < r, z = \phi(y)\}.$$

Fix  $\delta \in (0, r_0)$  sufficiently small, so that the function

$$\{|y| \leq \delta\} \ni y \mapsto g(y) = |y|^2 - |\phi(y)|^2 \in \mathbb{R}$$

is nonnegative and convex, with a unique critical point at the origin. Such a choice is possible since  $\phi(0) = 0$  and the differential of  $\phi$  at 0 is trivial.

For  $\varepsilon > 0$  sufficiently small we have  $W_I^\varepsilon \subset \mathcal{N}'_I$  and

$$\begin{aligned} W_I^\varepsilon &= \{x = y + z; |y| \leq \delta, z = \phi(y), 0 \leq |y|^2 - |\phi(y)|^2 \leq \varepsilon\} \\ &= \{x = y + z; |y| \leq r_0, z = \phi(y), g(y) \leq \varepsilon\}. \end{aligned}$$

The set

$$\mathcal{O}_{g,\varepsilon} := \{y \in \mathcal{P}_I; |y| \leq \delta, g(y) \leq \varepsilon\}$$

is a compact convex neighborhood of the origin with smooth boundary. It defines a relative homology class  $[\mathcal{O}_{g,\varepsilon}, \partial\mathcal{O}_{g,\varepsilon}]$  that coincides with the class  $v_I(\varepsilon)$ . It also coincides with  $u_I(\varepsilon)$  as can be seen using the homotopy

$$[0, 1] \times \mathcal{O}_{g,\varepsilon} \rightarrow \mathcal{P}, \quad (t, y) \mapsto y + t\phi(y).$$

(b) The equality  $i_*w_I = u_I$  follows directly from the definition of  $i_*$  using a triangulation of  $W_I$ . The equality  $\partial u_I = 0$  is then a consequence of the identity  $\partial i_* = 0$ .  $\square$

*Remark 3.7.* (a) If we form the Floer complex of  $f|_{W^*}$  then the result in Lemma 3.6 and the considerations in Section 2.5 imply that the boundary maps of this complex are trivial.

(b) The results in Lemma 3.6 are manifestations of a more general phenomenon. Suppose  $f : M \rightarrow \mathbb{R}$  is a proper Morse function on a smooth manifold  $M$ , and  $p$  is a critical point of  $f$  of index  $\lambda$ , and  $f(p) = 0$ . We say that  $p$  is of *Bott-Samelson type* if there exists a compact oriented manifold  $X$  of dimension  $\lambda$  and a smooth map  $\Phi : X \rightarrow M$  such that

$$\Phi(X) \subset \{f \leq 0\}, \quad \Phi(X) \cap \{f = 0\} = \{p\},$$

and the point  $x_0 = \Phi^{-1}(p)$  is a nondegenerate maximum of  $f \circ \Phi : X \rightarrow \mathbb{R}$ . Using unstable disks as in Section 2.5 we obtain a homology class

$$\langle p | \in H_\lambda(M^\varepsilon, M^{-\varepsilon}).$$

Then (see [PT, §10.3])

$$\langle p | = i_*\Phi_*[X],$$

where  $[X] \in H_\lambda(X)$  is the orientation class and

$$i_* : H_\bullet(M^\varepsilon) \rightarrow H_\bullet(M^\varepsilon, M^{-\varepsilon})$$

is the natural morphism. In particular,  $\partial\langle p | = 0$ . Note that Lemma 3.5 states that the critical points  $\theta_I$  of  $f$  are of Bott-Samelson type.  $\square$

Lemma 3.6 implies that for any critical value  $c < 0$  of  $f$ , and any sufficiently small  $\varepsilon > 0$  the connecting morphism

$$\partial : H_\bullet(W^{c+\varepsilon}, W^{c-\varepsilon}) \rightarrow H_{\bullet-1}(W^{c-\varepsilon})$$

is trivial. Thus for any  $k > 0$  we have short exact sequences,

$$0 \rightarrow H_k(W^{c-\varepsilon}) \rightarrow H_k(W^{c+\varepsilon}) \rightarrow H_k(W^{c+\varepsilon}, W^{c-\varepsilon}) \rightarrow 0 \quad (3.1)$$

while for  $k = 0$  we have an exact sequence

$$0 \rightarrow H_0(W^{c-\varepsilon}) \rightarrow H_0(W^{c+\varepsilon}) \rightarrow H_0(W^{c+\varepsilon}, W^{c-\varepsilon}).$$

Let  $c_1 < c_2 < \dots < c_\nu$  be all the critical values of  $f|_{W^*}$ . Set  $c_{\nu+1} = 0$ . Fix

$$\varepsilon < \frac{1}{2} \min_{1 \leq k \leq \nu} (c_{k+1} - c_k).$$

Observe that  $f$  has a unique local minimum corresponding to the critical point  $\theta_{I_n}$ ,  $I_n = \{1, \dots, n\}$ . Thus  $W^{c_1+\varepsilon}$  has the homotopy type of a point, and its homology is generated by the point  $W_{I_n}$ . Using (3.1) inductively we deduce that  $H_\bullet(W^{-\varepsilon}, \mathbb{Z})$  is a free Abelian group and the collection of homology classes  $[W_I] \in H_{\lambda_I}(W^{-\varepsilon})$ ,  $I \in \mathcal{L}_r^+$  is an integral basis of  $H_\bullet(W^{-\varepsilon})$ . This completes Step **A** of our strategy.

Consider the diffeomorphisms  $\mathbf{q}$  and  $\Psi$  that we used in the proof of Proposition 3.1,

$$T^{n-1} = (S^1)^{n-1} \xrightarrow{\Psi} (S^1)^n/S^1 \xrightarrow{\mathbf{q}} W,$$

where we recall that

$$\Psi(\theta_1, \dots, \theta_n) = (\psi_2, \dots, \psi_n) \in (\mathbb{R}/2\pi\mathbb{Z})^{n-1}, \quad \psi_k = \theta_k - \theta_1 \pmod{2\pi}.$$

For every  $J \subset \{2, \dots, n\}$  we set

$$T_J = \{(\psi_2, \dots, \psi_n); \psi_j = 0 \pmod{2\pi}, \forall j \in J\}.$$

Then  $T_J \subset T^{n-1}$  is a torus of dimension  $(n-1) - \#J$  and, upon fixing an orientation, we obtain a homology class  $[T_J] \in H_{n-1-\#J}(T^{n-1}, \mathbb{Z})$ . The collection

$$\{[T_J]; J \subset \{2, \dots, n\}\},$$

is an integral basis of  $H_\bullet(T^{n-1}, \mathbb{Z})$ . Note that

$$\mathbf{q}\Psi^{-1}(T_J) = W_{\hat{J}}, \quad \hat{J} = J \cup \{1\}.$$

This proves that the collection

$$\{[W_j]; J \subset \{2, \dots, n\}\} \quad (3.2)$$

is an integral basis of  $H_\bullet(W, \mathbb{Z})$ .

A subset  $I \subset \{2, \dots, n\}$  defines a homology class  $[W_I] \in H_{n-\#I}(W, \mathbb{Z})$  and thus can be written as a linear combination of classes  $[W_j]$ ,  $J \subset \{2, \dots, n\}$ . More precisely, we have the following result.

**Lemma 3.8.** *Let  $I \subset \{2, \dots, n\}$ . Then*

$$[W_I] = \sum_{i \in I} \pm [W_{\hat{i}}], \quad I_i = I \setminus \{i\}.$$

*Proof.* Consider the diffeomorphism  $\Phi = \Psi \circ \mathbf{q}^{-1} : W \rightarrow T^{n-1}$

$$[\theta_1, \dots, \theta_n] \mapsto (\psi_2, \dots, \psi_n) = (\theta_2 - \theta_1, \dots, \theta_n - \theta_1).$$

Thus

$$\Phi(W_I) = \{(\psi_2, \dots, \psi_{n-1}) \in T^{n-1}; \psi_{i_1} = \psi_{i_2}, \forall i_1, i_2 \in I\}.$$

Denote by  $I^c$  the complement of  $I$  in  $\{2, \dots, n\}$ . Then the torus  $T_I$  has angular coordinates  $(\psi_j)_{j \in I^c}$ , while the torus  $T_{I^c}$  has angular coordinates  $(\psi_i)_{i \in I}$ . Denote by  $\Delta$  the “diagonal” simple closed curve on  $T_{I^c}$  given by the equalities

$$\psi_{i_1} = \psi_{i_2}, \forall i_1, i_2 \in I.$$

We have a canonical diffeomorphism  $F : T_{I^c} \times T_I \rightarrow T^{n-1}$  and we observe

$$\Phi(W_I) = F(\Delta \times T_I)$$

We fix an orientation on  $C$  and we denote by  $[C]$  the resulting cohomology class. We leave to the reader as an exercise (Exercise 6.25) to verify that in  $H_1(T_{I^c})$  we have the equality

$$[\Delta] = \sum_{i \in I} \pm [E_i], \quad (3.3)$$

where  $E_i$  is the simple closed curve in  $T_{I^c}$  given by the equalities

$$\psi_j = 0, \forall j \in I_i.$$

Using Künneth theorem we deduce that

$$\Phi_*[W_I] = \sum_{i \in I} \pm F_*([E_i] \times [T_I]) = \sum_{i \in I} \pm [T_{I_i}]. \quad \square$$

The group  $H_\bullet(W^{-\varepsilon})$  admits a direct sum decomposition

$$H_\bullet(W^{-\varepsilon}) = A_\bullet \oplus B_\bullet,$$

where

- $A_\bullet$  is spanned by the classes  $[W_I]$ ,  $I \in \mathcal{L}_r^+$ ,  $I \ni 1$ ,
- $B_\bullet$  is spanned by the classes  $[W_J]$ ,  $J \in \mathcal{L}_r^+$ ,  $J \not\ni 1$ .

Similarly, we have a direct sum decomposition

$$H_\bullet(W, \mathbb{Z}) = A_\bullet \oplus C_\bullet$$

where  $A_\bullet$  is as above, and

- $C_\bullet$  is spanned by the classes  $[W_J]$ ,  $J \subset \{2, \dots, n\}$ ,  $\hat{J} \in \mathcal{L}_r^-$ .

Thus, the inclusion induced morphism  $j_* : H_\bullet(W^{-\varepsilon}) \rightarrow H_\bullet(W)$  has a block decomposition

$$i_* = \begin{bmatrix} \alpha & \beta \\ \gamma & \delta \end{bmatrix} : \begin{matrix} A_\bullet & A_\bullet \\ \oplus & \longrightarrow \oplus \\ B_\bullet & C_\bullet \end{matrix}.$$

**Lemma 3.9.**

$$\alpha = \mathbb{1}_{A_\bullet}, \quad \gamma = 0, \quad \delta = 0.$$

*Proof.* Clearly  $j_*|_{A_\bullet} = \mathbb{1}_{A_\bullet}$  which implies  $\alpha = \mathbb{1}_{A_\bullet}$  and  $\gamma = 0$ .

Let  $J \in \mathcal{L}_r^+$ , and  $1 \notin J$ , so that  $[W_J] \in B_\bullet$ . Lemma 3.8 implies that

$$j_*[W_J] = \sum_{j \in J} \pm [W_{\hat{J}_j}].$$

Observe that since  $\mathbf{r}$  is ordered we have

$$r(\hat{J}_j) = r(J) - r_j + r_1 \geq r(J) > 0.$$

Hence all of the subsets  $\hat{J}_j$ ,  $j \in J$  are long. The above equality implies that  $j_*[W_J] \in A_\bullet$ , i.e.,  $\delta[W_J] = 0$ .  $\square$

Lemma 3.9 implies that the range of the morphism  $j_k : H_k(W^{-\varepsilon}) \rightarrow H_k(W)$  is the free Abelian group  $A_k$ . Hence

$$\text{coker } j_k \cong C_k, \quad \text{rank ker } j_k = \text{rank } B_k.$$

Consider now the long exact sequence of the pair  $(W, W^{-\varepsilon})$ ,

$$\dots \xrightarrow{\partial} H_k(W^{-\varepsilon}) \xrightarrow{j_k} H_k(W) \xrightarrow{i_k} H_k(W, W^{-\varepsilon}) \xrightarrow{\partial} H_{k-1}(W^{-\varepsilon}) \xrightarrow{j_{k-1}} \dots$$

This yields a short exact sequence ( $k \geq 1$ )

$$0 \rightarrow C_k \rightarrow H_k(W, W^{-\varepsilon}) \rightarrow \text{ker } j_{k-1} \rightarrow 0.$$

Hence  $H_k(W, W^{-\varepsilon})$  is a free Abelian group and its rank is

$$\text{rank } H_k(W, W^{-\varepsilon}) = \text{rank } C_k + \text{rank } B_{k-1}.$$

From the excision theorem we deduce that  $H_k(N_\varepsilon, \partial N_\varepsilon) \cong H_k(W, W^{-\varepsilon})$  so that  $H_k(N_\varepsilon, \partial N_\varepsilon)$  is free Abelian and

$$\text{rank } H_k(N_\varepsilon, \partial N_\varepsilon) = \text{rank } C_k + \text{rank } B_{k-1}.$$

The Poincaré-Lefschetz duality and the universal coefficients theorem now imply that for  $\forall 0 \leq \ell \leq n - 3$  we have

$$\text{rank } H_k(\mathcal{M}_{\mathbf{r}}) = \text{rank } H_\ell(N_\varepsilon) = \text{rank } C_{n-1-k} + \text{rank } B_{n-2-k}.$$

Observe that  $\text{rank } C_{n-1-k}$  can be identified with the number of subsets  $J$  of  $\{2, \dots, n\}$  such that

$$\hat{J} \in \mathcal{L}_{\mathbf{r}}^-, \quad n - \#\hat{J} = n - k - 1.$$

In other words,  $\text{rank } C_{n-1-k} = a_k(\mathbf{r})$ .

Similarly,  $\text{rank } B_{n-2-k}$  can be identified with the number of long subsets  $J \subset \{2, \dots, n\}$  such that  $n - 2 - k = n - \#J$ . The complement of such a subset in  $\{1, \dots, n\}$  is a short subset of cardinality  $n - 2 - k$  that contains one, i.e.,  $\text{rank } B_{n-2-k} = a_{n-3-k}(\mathbf{r})$ . This concludes the proof of Theorem 3.3.  $\square$

**Proof of Lemma 3.5.** On  $W_I$  we have  $\theta_{i_1} = \theta_{i_2}, \forall i_1, i_2 \in I$ . Denote by  $\theta_0$  the common value of these angular coordinates. The restriction  $f_I$  of  $f$  to  $W_I$  can now be rewritten as

$$f_I = - \left| r_0 e^{i\theta_0} + \sum_{j \in I^c} r_j e^{i\theta_j} \right|^2,$$

where  $I^c$  denotes the complement of  $I$  in  $\{1, \dots, n\}$  and  $r_0 = \sum_{i \in I} r_i$ . Suppose  $I^c = \{j_1 < \dots < j_k\}$ . Form a new robot arm with arm lengths  $r_0, r_{j_1}, \dots, r_{j_k}$ . The torus  $W_I$  can be identified with the work space of this robot arm. Note that since  $I$  is a long subset we have

$$r_0 > r_{j_1} + \dots + r_{j_k}$$

so that the end joint of this arm can never reach the origin. Thus  $W_I$  can be identified with the configuration space of this robot arm as defined in Example 1.5 and  $f_I < 0$  on  $W_I$ . Arguing as in the proof of Lemma 3.4 we deduce that  $f_I$  is a Morse function. The minimum distance from the origin to the end joint is realized for a unique collinear configuration namely,  $\theta_0 = 0, \theta_j = \pi, j \in I^c$ . Thus

$$\max_{W_I} f_I = -(r_0 r_{j_1} - \dots - r_{j_k})^2 = f(\boldsymbol{\theta}_I).$$

This maximum is nondegenerate because  $f_I$  is Morse.  $\square$

**Example 3.10.** (a) Suppose  $n$  is an odd number,  $n = 2\nu + 1$ . Then the length vector  $\mathbf{r} = (1, \dots, 1) \in \mathbb{R}^n$  is ordered and satisfies the genericity condition (1.1). In this case a subset  $I$  is long if and only if  $\#I \geq \nu + 1$ . We deduce that

$$a_k = \begin{cases} \binom{n-1}{k}, & k \leq \nu - 1 \\ 0, & k > \nu - 1, \end{cases} \quad a_{n-3-k} = \begin{cases} \binom{n-1}{k+2}, & k \geq \nu - 1 \\ 0, & k < \nu - 1, \end{cases}$$

so that

$$b_k(\mathcal{M}_{\mathbf{r}}) = \begin{cases} \binom{2\nu}{k}, & k < \nu - 1 \\ \binom{2\nu}{\nu-1} + \binom{2\nu}{\nu+1}, & k = \nu - 1 \\ \binom{2\nu}{k+2}, & k > \nu - 1. \end{cases}$$

For  $n = 5, \nu = 2$  the moduli space  $\mathcal{M}_{\mathbf{r}}$  is 2-dimensional and its Poincaré polynomial is  $1 + 8t + t^2$ . This agrees with the conclusion of Example 2.11.

(b) At the other extreme suppose  $n \geq 5$  is arbitrary and

$$\mathbf{r} = (r_1, r_2, \dots, r_{n-1}, r_n) = (n - 1 - \varepsilon, 1, 1, \dots, 1), \quad 0 < \varepsilon < 1.$$

Then  $\mathbf{r}$  is ordered and satisfies (1.1). A subset  $I \subset \{1, \dots, n\}$  is  $\mathbf{r}$ -short if and only if either  $I = \{1\}$ , or  $1 \notin I$ . Then the Poincaré polynomial  $P_{\mathbf{r}}(t)$  of  $\mathcal{M}_{\mathbf{r}}$  is  $1 + t^{n-3}$ .

(c) Suppose

$$\mathbf{r} = (r_1, \dots, r_n) = (n - 2j + \varepsilon, 1, \dots, 1), \quad 0 < \varepsilon \ll 1, \quad 2j < n - 3.$$

Consider a subset  $I \subset \{1, \dots, n\}$  of cardinality  $k + 1$  that contains 1. Then  $I$  is  $\mathbf{r}$ -short if and only if  $k < j$ . Hence

$$a_k(\mathbf{r}) = \begin{cases} 0, & k \geq j, \\ \binom{n-1}{k}, & k < j, \end{cases}, \quad a_{n-3-k}(\mathbf{r}) = \begin{cases} \binom{n-1}{k+2}, & k > n - 3 - j \\ 0, & k \leq n - 3 - j. \end{cases}$$

We deduce

$$P_{\mathbf{r}}(t) = \sum_{k=0}^{j-1} \binom{n-1}{k} t^k + \sum_{k=n-2-j}^{n-3} \binom{n-1}{k+2} t^k. \quad \square$$

### 3.2 The Cohomology of Complex Grassmannians

Denote by  $G_{k,n}$  the Grassmannian of complex  $k$ -dimensional subspaces of an  $n$ -dimensional complex vector space. The Grassmannian  $G_{k,n}$  is a complex manifold of complex dimension  $k(n - k)$  (see Exercise 6.29) and we have a diffeomorphism  $G_{k,n} \rightarrow G_{n-k,n}$  which associates to each  $k$ -dimensional subspace its orthogonal complement with respect to a fixed Hermitian metric on the ambient space. Denote by  $P_{k,n}(t)$  the Poincaré polynomial of  $G_{k,n}$  with rational coefficients. In this section we will present a Morse theoretic computation of  $P_{k,n}(t)$ .

**Proposition 3.11.** *For every  $1 \leq k \leq n$  the polynomial  $P_{k,n}(t)$  is even, i.e., the odd Betti numbers of  $G_{k,n}$  are trivial. Moreover,*

$$P_{k,n+1}(t) = P_{k,n}(t) + t^{2(n+1-k)} P_{k-1,n}(t), \quad \forall 1 \leq k \leq n.$$

*Proof.* We carry out an induction on  $\nu = k + n$ . The statement is trivially valid for  $\nu = 2$ , i.e.,  $(k, n) = (1, 1)$ .

Suppose that  $U$  is a complex  $n$ -dimensional vector space equipped with a Hermitian metric  $(\bullet, \bullet)$ . Set  $V := \mathbb{C} \oplus U$  and denote by  $e_0$  the standard basis of  $\mathbb{C}$ . The metric on  $U$  defines a metric on  $V$ , its direct sum with the standard metric on  $\mathbb{C}$ . For every complex Hermitian vector space  $W$  we denote by  $G_k(W)$  the Grassmannian of  $k$ -dimensional complex subspaces of  $W$  and by  $S(W)$  the linear space of Hermitian linear operators  $T : W \rightarrow W$ . Note that we have a natural map

$$G_k(W) \rightarrow S(W), \quad L \mapsto P_L,$$

where  $P_L : W \rightarrow W$  denotes the orthogonal projection on  $L$ . This map is a smooth embedding. (See Exercise 6.29.)

Denote by  $A : \mathbb{C} \oplus U \rightarrow \mathbb{C} \oplus U$  the orthogonal projection onto  $\mathbb{C}$ . Then  $A \in S(V)$  and we define

$$f : S(V) \rightarrow \mathbb{R}, \quad f(T) = \mathbf{Re} \operatorname{tr}(AT).$$

This defines a smooth function on  $G_k(V)$ ,

$$L \mapsto f(L) = \mathbf{Re} \operatorname{tr}(AP_L) = (P_L e_0, e_0).$$

Equivalently,  $f(L) = \cos^2 \angle(e_0, L)$ . Observe that we have natural embeddings  $G_k(U) \hookrightarrow G_k(V)$  and

$$G_{k-1}(U) \rightarrow G_k(V), \quad G_{k-1}(U) \ni L \mapsto \mathbb{C}e_0 \oplus L.$$

**Lemma 3.12.**

$$\begin{aligned} 0 \leq f \leq 1, \quad \forall L \in G_k(V), \\ f^{-1}(0) = G_k(U), \quad f^{-1}(1) = G_{k-1}(U). \end{aligned}$$

*Proof.* If  $L \subset V$  is a  $k$ -dimensional subspace, we have  $0 \leq (P_L e_0, e_0) \leq 1$ . Observe that

$$\begin{aligned} (P_L e_0, e_0) = 1 &\iff e_0 \in L, \\ (P_L e_0, e_0) = 0 &\iff e_0 \in L^\perp \iff L \subset (e_0)^\perp = U. \end{aligned}$$

Hence for  $i = 0, 1$  we have  $S_i = \{f = i\} = G_{k-i}(U)$ . □

**Lemma 3.13.** *The only critical values of  $f$  are 0 and 1.*

*Proof.* Let  $L \in G_k(V)$  such that  $0 < f(L) < 1$ . This means that

$$0 < (P_L e_0, e_0) = \cos^2 \angle(e_0, L) < 1.$$



In particular,  $L$  intersects the hyperplane  $U \subset V$  transversally along a  $(k-1)$ -dimensional subspace  $L' \subset L$ . Fix an orthonormal basis  $e_1, \dots, e_{k-1}$  of  $L'$  and extend it to an orthonormal basis  $e_1, \dots, e_n$  of  $U$ . Then

$$L = L' + \mathbb{C}\mathbf{v}, \quad \mathbf{v} = c_0 e_0 + \sum_{j \geq k} c_j e_j, \quad |c_0|^2 + \sum_{j \geq k} |c_j|^2 = 1$$

and  $(P_L e_0, e_0) = |c_0|^2$ . If we choose

$$\mathbf{v}(t) = a_0(t) e_0 + \sum_{j \geq k} a_j(t) e_j, \quad |a_0(t)|^2 = 1 - \sum_{j \geq k} |a_j(t)|^2,$$

such that  $a_0(t)$  and  $a_j(t)$  depend smoothly on  $t$ ,  $\frac{d|a_0|^2}{dt}|_{t=0} \neq 0$ ,  $a_0(0) = c_0$ , then

$$t \mapsto L_t = L' + \mathbb{C}\mathbf{v}(t)$$

is a smooth path in  $G_k(V)$  and  $\frac{df}{dt}(L_t)|_{t=0} \neq 0$ . This proves that  $L_0 = L$  is a regular point of  $f$ .  $\square$

**Lemma 3.14.** *The level sets  $S_i = f^{-1}(i)$ ,  $i = 0, 1$ , are nondegenerate critical manifolds.*

*Proof.* Observe that  $S_0$  is a complex submanifold of  $G_k(V)$  of complex dimension  $k(n-k)$  and thus complex codimension

$$\text{codim}_{\mathbb{C}}(S_0) = k(n+1-k) - k(n-k) = k.$$

Similarly,

$$\text{codim}_{\mathbb{C}}(S_1) = (n+1-k)k - (n+1-k)(k-1) = (n-k+1).$$

To prove that  $S_0$  is a nondegenerate critical manifold it suffices to show that for every  $L \in S_0 = G_k(U)$  there exists a smooth map  $\Phi : \mathbb{C}^k \rightarrow G_k(V)$  such that

$$\Phi(0) = L, \quad \Phi \text{ is an immersion at } 0 \in \mathbb{C}^k,$$

and

$$f \circ \Phi \text{ has a nondegenerate minimum at } 0 \in \mathbb{C}^k.$$

For every  $u \in U$  denote by  $X_u : V \rightarrow V$  the skew-Hermitian operator defined by

$$X_u(e_0) = u, \quad X_u(v) = -(v, u)e_0, \quad \forall v \in U.$$

Observe that the map  $U \ni u \mapsto X_u \in \text{Hom}_{\mathbb{C}}(V, V)$  is  $\mathbb{R}$ -linear. The operator  $X_u$  defines a 1-parameter family of unitary maps  $e^{tX_u} : V \rightarrow V$ . Set

$$\bar{\Phi}(u) := e^{X_u} L, \quad P(u) := P_{\bar{\Phi}(u)}.$$

Then

$$P(u) = e^{X_u} P_L e^{-X_u}, \quad \dot{P}_u = \left. \frac{dP(tu)}{dt} \right|_{t=0} = [X_u, P_L]$$

and

$$(\dot{P}_u e_0, u) = -(P_L X_u(e_0), u) = -|u|^2,$$

so that if  $u \in L$  we have

$$\dot{P}_u = 0 \implies u = 0.$$

This proves that the map

$$L \rightarrow G_k(V), \quad L \ni u \mapsto \Phi(u) \in G_k(V),$$

is an immersion at  $u = 0$ . Let us compute  $f(\Phi(u))$ . We have

$$\begin{aligned} f(\Phi(u)) &= (P(u)e_0, e_0) = (P_L e^{-X_u} e_0, e^{-X_u} e_0) \\ &= \left( P_L \left( 1 - X_u + \frac{1}{2} X_u^2 - \cdots \right) e_0, \left( 1 - X_u + \frac{1}{2} X_u^2 - \cdots \right) e_0 \right) \\ &= (P_L X_u e_0, X_u e_0) + \cdots = |u|^2 + \cdots, \end{aligned}$$

where at the last step we used the equalities  $X_u e_0 = u$ ,  $P_L u = u$ ,  $P_L e_0 = 0$ . Hence

$$\left. \frac{d^2 f(\Phi(tu))}{dt^2} \right|_{t=0} = 2(P_L X_u e_0, X_u e_0) = 2|u|^2.$$

This shows that  $0 \in L$  is a nondegenerate minimum of  $L \ni u \mapsto f(\Phi(u)) \in \mathbb{R}$ , and since  $\dim_{\mathbb{C}} L = \text{codim}_{\mathbb{C}} S_0$ , we deduce that  $S_0$  is a nondegenerate critical manifold.

Let  $L \in S_1$ . Denote by  $L_0$  the intersection of  $L$  and  $U$  and by  $L'_0$  the orthogonal complement of  $L_0$  in  $U$ . Observe that

$$\dim_{\mathbb{C}} L'_0 = n - k + 1 = \text{codim}_{\mathbb{C}} S_1,$$

and we will show that the smooth map

$$\Phi : L'_0 \rightarrow G_k(V), \quad u \mapsto \Phi(u) = e^{X_u} L$$

is an immersion at  $0 \in L'_0$  and that  $f \circ \Phi$  has a nondegenerate maximum at 0.

Again we set  $P(u) = P_{\Phi(u)}$  and we have

$$\begin{aligned} \dot{P}_u &:= \left. \frac{dP(tu)}{dt} \right|_{t=0} = [X_u, P_L], \\ \dot{P}_u e_0 &= X_u P_L e_0 - P_L X_u e_0 = X_u e_0 = u \implies (\dot{P}_u e_0, u) = |u|^2. \end{aligned}$$

Now observe that

$$\begin{aligned} f(\Phi(u)) &= (P_L e^{-X_u} e_0, e^{-X_u} e_0) \\ &= \left( P_L \left( 1 - X_u + \frac{1}{2} X_u^2 + \cdots \right) e_0, \left( 1 - X_u + \frac{1}{2} X_u^2 + \cdots \right) e_0 \right) \end{aligned}$$

$$\begin{aligned}
 (X_u e_0 = u, P_L X_u e_0 = 0) \\
 &= \left( e_0 + \frac{1}{2} X_u^2 e_0 + \cdots, e_0 - u + \frac{1}{2} X_u^2 e_0 \right) \\
 &= |e_0|^2 + \frac{1}{2} (X_u^2 e_0, e_0) + \frac{1}{2} (e_0, X_u^2 e_0) + \cdots \\
 (X_u^* = -X_u) \\
 &= 1 - (X_u e_0, X_u e_0) + \cdots = 1 - |u|^2 + \cdots .
 \end{aligned}$$

This shows that  $S_1$  is a nondegenerate critical manifold.  $\square$

*Remark 3.15.* The above computations can be refined to prove that the normal bundle of  $S_0 = G_k(U) \hookrightarrow G_k(V)$  is isomorphic as a complex vector bundle to the dual of the tautological vector bundle on the Grassmannian  $G_k(U)$ , while the normal bundle of  $S_1 = G_{k-1}(U) \hookrightarrow G_k(V)$  is isomorphic to the dual of the tautological quotient bundle on the Grassmannian  $G_{k-1}(U)$ .  $\square$

We have

$$\lambda(f, S_0) = 0, \quad \lambda(f, S_1) = 2(n+1-k).$$

The negative bundles  $E^-(S_i)$  are orientable since they are complex vector bundles

$$E^-(S_0) = 0, \quad E^-(S_1) = T_{S_1} G_k(V).$$

Since  $S_0 \cong G_{k,n}$ ,  $S_1 \cong G_{k-1,n}$ , we deduce from the induction hypothesis that the Poincaré polynomials  $P_{S_i}(t)$  are even. Hence the function  $f$  is a perfect Morse–Bott function, and we deduce

$$P_{G_k(V)} = P_{S_0}(t) + t^{2(n+1-k)} P_{S_1}(t),$$

or

$$P_{k,n+1}(t) = P_{k,n}(t) + t^{2(n+1-k)} P_{k-1,n}(t). \quad \square$$

Let us make a change in variables

$$Q_{k,\ell} = P_{k,n}, \quad \ell = (n-k).$$

The last identity can be rewritten

$$Q_{k,\ell+1} = Q_{k,\ell} + t^{2(\ell+1)} Q_{k-1,\ell+1}.$$

On the other hand,  $Q_{k,\ell} = Q_{\ell,k}$ , and we deduce

$$Q_{k,\ell+1} = Q_{\ell+1,k} = Q_{\ell+1,k-1} + t^{2k} Q_{\ell,k}.$$

Subtracting the last two equalities, we deduce

$$(1 - t^{2k}) Q_{k,\ell} = (1 - t^{2(\ell+1)}) Q_{k-1,\ell+1}.$$

We deduce

$$Q_{k,\ell} = \frac{(1-t^{2(\ell+1)})}{(1-t^{2k})} Q_{k-1,\ell+1} \implies P_{k,n} = \frac{(1-t^{2(n-k+1)})}{(1-t^{2k})} P_{k-1,n}.$$

Iterating, we deduce that the Poincaré polynomial of the complex Grassmannian  $G_{k,n}$  is

$$P_{k,n}(t) = \frac{\prod_{j=(n-k+1)}^n (1-t^{2j})}{\prod_{i=1}^k (1-t^{2i})} = \frac{\prod_{i=1}^n (1-t^{2i})}{\prod_{j=1}^k (1-t^{2j}) \prod_{i=1}^{n-k} (1-t^{2i})}.$$

*Remark 3.16.* The above analysis can be further refined and generalized. We leave most of the details to the reader as an exercise (Exercise 6.32).

Suppose  $E$  is a finite dimensional real Euclidean space, and  $A \in \text{End}(E)$  is a symmetric endomorphism. Denote by  $\text{Gr}_k(E)$  the Grassmannian of  $k$ -dimensional subspaces of  $E$ . For every  $L \in \text{Gr}_k(E)$  we denote by  $P_L$  the orthogonal projection onto  $L$ . The map

$$\text{Gr}_k(E) \ni L \mapsto P_L \in \text{End } E$$

embeds  $\text{Gr}_k(E)$  as a (real algebraic) submanifold of  $\text{End}(E)$ . On  $\text{End}(E)$  we have an inner product given by

$$\langle S, T \rangle = \text{tr}(ST^*).$$

We denote by  $|\bullet|$  the corresponding Euclidean norm on  $\text{End}(E)$ . This inner product induces a smooth Riemann metric on  $\text{Gr}_k(E)$ .

The function

$$f_A : \text{Gr}_k(E) \rightarrow \mathbb{R}, \quad f_A(L) = \text{tr } AP_L = \langle A, P_L \rangle. \quad (3.4)$$

This is a Morse-Bott function whose critical points are the  $k$ -dimensional invariant subspaces of  $A$ . Its gradient flow has an explicit description,

$$\text{Gr}_k(E) \ni L \mapsto e^{At} L \in \text{Gr}_k(E) \quad (3.5)$$

We want to point out a simple application of these facts that we will need later.

Suppose  $U$  is a subspace of  $E$ ,  $\dim U \leq k$ , and define

$$A := P_{U^\perp} = \mathbb{1}_E - P_U.$$

Then

$$f_A(L) = \text{tr}(P_L - P_L P_U) = \dim L - \text{tr}(P_L P_U).$$

On the other hand, we have

$$|P_U - P_U P_L|^2 = \text{tr}(P_U - P_U P_L)(P_U - P_L P_U) = \text{tr}(P_U - P_U P_L P_U)$$

$$= \operatorname{tr} P_U - \operatorname{tr} P_U P_L P_U = \dim U - \operatorname{tr} P_U P_L.$$

Hence

$$f_A(L) = |P_U - P_U P_L|^2 + \dim L - \dim U,$$

so that

$$f_A(L) \geq \dim L - \dim U,$$

with equality if and only if  $L \supset U$ . Thus, the set of minima of  $f_A$  consists of all  $k$ -dimensional subspaces containing  $U$ . We denote this set with  $\operatorname{Gr}_k(E)_U$ . Since  $f_A$  is a Morse-Bott function we deduce that

$$\begin{aligned} \forall j \leq k, \forall U \in \operatorname{Gr}_j(E), \exists C = C(U) > 1, \forall L \in \operatorname{Gr}_k(E) : \\ \frac{1}{C} \operatorname{dist}(L, \operatorname{Gr}_k(E)_U)^2 \leq |P_U - P_U P_L|^2 \leq C \operatorname{dist}(L, \operatorname{Gr}_k(E)_U)^2. \end{aligned} \tag{3.6}$$

In a later section we will prove more precise results concerning the asymptotics of this Grassmannian flow.  $\square$

### 3.3 The Lefschetz Hyperplane Theorem

A *Stein manifold* is a complex submanifold  $M$  of  $\mathbb{C}^\nu$  such that the natural inclusion  $M \hookrightarrow \mathbb{C}^\nu$  is a proper map. Let  $m$  denote the *complex* dimension of  $M$  and denote by  $\zeta = (\zeta^1, \dots, \zeta^\nu)$  the complex linear coordinates on  $\mathbb{C}^\nu$ . We set  $i = \sqrt{-1}$ .

**Example 3.17.** Suppose  $M \subset \mathbb{C}^\nu$  is an affine algebraic submanifold of  $\mathbb{C}^\nu$ , i.e., there exist polynomials  $P_1, \dots, P_r \in \mathbb{C}[\zeta^1, \dots, \zeta^\nu]$  such that

$$M = \{ \zeta \in \mathbb{C}^\nu; P_i(\zeta) = 0, \forall i = 1, \dots, r \}.$$

Then  $M$  is a Stein manifold.  $\square$

Suppose  $M \hookrightarrow \mathbb{C}^\nu$  is a Stein manifold. Modulo a translation of  $M$  we can assume that the function  $f : \mathbb{C}^\nu \rightarrow \mathbb{R}, f(\zeta) = |\zeta|^2$  restricts to a Morse function which is necessarily exhaustive because  $M$  is properly embedded. The following theorem due to A. Andreotti and T. Frankel [AF] is the main result of this section.

**Theorem 3.18.** *The Morse indices of critical points of  $f|_M$  are not greater than  $m$ .*  $\square$

**Corollary 3.19.** *A Stein manifold of complex dimension  $m$  has the homotopy type of an  $m$ -dimensional CW complex.<sup>1</sup> In particular,*

<sup>1</sup> With a bit of extra work one can prove that if  $X$  is affine *algebraic*, then  $f$  has only *finitely* many critical points, so  $X$  is homotopic to a compact CW complex. There exist, however, Stein manifolds for which  $f$  has infinitely many critical values.

$$H_k(M, \mathbb{Z}) = 0, \quad \forall k > m. \quad \square$$

Before we begin the proof of Theorem 3.18 we need to survey a few basic facts of complex differential geometry.

Suppose  $M$  is a complex manifold of complex dimension  $m$ . Then the (real) tangent bundle  $TM$  is equipped with a natural automorphism

$$J : TM \rightarrow TM$$

satisfying  $J^2 = -1$  called the associated *almost complex structure*. If  $(z^k)_{1 \leq k \leq m}$  are complex coordinates on  $M$ ,  $z^k = x^k + iy^k$ , then

$$J\bar{\partial}_{x^k} = \partial_{y^k}, \quad J\partial_{y^k} = -\bar{\partial}_{x^k}.$$

We can extend  $J$  by complex linearity to the complexified tangent bundle,

$$J_c : {}^cTM \rightarrow {}^cTM, \quad {}^cTM := TM \otimes_{\mathbb{R}} \mathbb{C}.$$

The equality  $J^2 = -1$  shows that  $\pm i$  are the only eigenvalues of  $J_c$ . If we set

$$TM^{1,0} := \ker(\mathbf{i} - J_c), \quad TM^{0,1} := \ker(\mathbf{i} + J_c),$$

then we get a direct sum decomposition

$${}^cTM = TM^{1,0} \oplus TM^{0,1}.$$

Locally  $TM^{1,0}$  is spanned by the vectors

$$\partial_{z^k} = \frac{1}{2}(\partial_{x^k} - \mathbf{i}\partial_{y^k}), \quad k = 1, \dots, m,$$

while  $TM^{0,1}$  is spanned by

$$\bar{\partial}_{z^k} = \frac{1}{2}(\partial_{x^k} + \mathbf{i}\partial_{y^k}), \quad k = 1, \dots, m.$$

We denote by  $\text{Vect}^c(M)$  the space of *smooth* sections of  ${}^cTM$ , and by  $\text{Vect}(M)$  the space of smooth sections of  $TM$ , i.e., *real* vector fields on  $M$ .

Given  $V \in \text{Vect}(M)$  described in local coordinates by

$$V = \sum_k (a^k \partial_{x^k} + b^k \partial_{y^k}),$$

and if we set  $v^k = a^k + \mathbf{i}b^k$ , we obtain the (local) equalities

$$V = \sum_k (v^k \partial_{z^k} + \bar{v}^k \bar{\partial}_{z^k}), \quad JV = \sum_k (\mathbf{i}v^k \partial_{z^k} - \mathbf{i}\bar{v}^k \bar{\partial}_{z^k}). \quad (3.7)$$

The operator  $J$  induces an operator  $J^t : T^*M \rightarrow T^*M$  that extends by complex linearity to  ${}^cT^*M$ . Again we have a direct sum decomposition

$${}^cT^*M = T^*M^{1,0} \oplus T^*M^{0,1},$$

$$T^*M^{1,0} = \ker(\mathbf{i} - J_c^t), \quad T^*M^{0,1} = \ker(\mathbf{i} + J_c^t).$$

Locally,  $T^*M^{1,0}$  is spanned by  $dz^k = dx^k + \mathbf{i}dy^k$ , while  $T^*M^{0,1}$  is spanned by  $d\bar{z}^k = dx^k - \mathbf{i}dy^k$ . The decomposition

$${}^cT^*M = T^*M^{1,0} \oplus T^*M^{0,1}$$

induces a decomposition of  $\Lambda^r {}^cT^*M$ ,

$$\Lambda^r {}^cT^*M = \bigoplus_{p+q=r} \Lambda^{p,q}T^*M, \quad \Lambda^{p,q}T^*M = \Lambda^p T^*M^{1,0} \otimes_{\mathbb{C}} \Lambda^q T^*M^{0,1}.$$

The bundle  $\Lambda^{p,q}T^*M$  is locally spanned by the forms  $dz^I \wedge d\bar{z}^J$ , where  $I, J$  are ordered multi-indices of length  $|I| = p$ ,  $|J| = q$ ,

$$I = (i_1 < i_2 < \cdots < i_p), \quad J = (j_1 < \cdots < j_q),$$

and

$$dz^I = dz^{i_1} \wedge \cdots \wedge dz^{i_p}, \quad d\bar{z}^J = d\bar{z}^{j_1} \wedge \cdots \wedge d\bar{z}^{j_q}.$$

We denote by  $\Omega^{p,q}(M)$  the space of smooth sections of  $\Lambda^{p,q}T^*M$  and by  $\Omega^r(M, \mathbb{C})$  the space of smooth sections of  $\Lambda^r {}^cT^*M$ . The elements of  $\Omega^{p,q}(M)$  are called  $(p, q)$ -forms.

The exterior derivative of a  $(p, q)$ -form  $\alpha$  admits a decomposition

$$d\alpha = (d\alpha)^{p+1,q} + (d\alpha)^{p,q+1}.$$

We set

$$\partial\alpha := (d\alpha)^{p+1,q}, \quad \bar{\partial}\alpha := (d\alpha)^{p,q+1}.$$

If  $f$  is a  $(0, 0)$ -form (i.e., a complex valued function on  $M$ ), then locally we have

$$\partial f = \sum_k (\partial_{z^k} f) dz^k, \quad \bar{\partial} f = \sum_k (\partial_{\bar{z}^k} f) d\bar{z}^k.$$

In general, if

$$\alpha = \sum_{|I|=p, |J|=q} \alpha_{IJ} dz^I \wedge d\bar{z}^J, \quad \alpha_{IJ} \in \Omega^{0,0}$$

then

$$\partial\alpha = \sum_{|I|=p, |J|=q} \partial\alpha_{IJ} \wedge dz^I \wedge d\bar{z}^J, \quad \bar{\partial}\alpha = \sum_{|I|=p, |J|=q} \bar{\partial}\alpha_{IJ} \wedge dz^I \wedge d\bar{z}^J.$$

We deduce that for every  $f \in \Omega^{0,0}(M)$  we have the local equality

$$\partial\bar{\partial}f = \sum_{j,k} \partial_{z^j} \partial_{\bar{z}^k} f dz^j \wedge d\bar{z}^k. \quad (3.8)$$

If  $U = \sum_j (a^j \partial_{x^k} + b^j \partial_{y^j})$  and  $V = \sum_k (c^k \partial_{x^k} + d^k \partial_{y^k})$  are locally defined real vector fields on  $M$  and we set

$$u^j = (a^j + \mathbf{i}b^j), \quad v^k = (c^k + \mathbf{i}d^k),$$

then using (3.8) we deduce

$$\partial\bar{\partial}f(U, V) = \sum_{j,k} (\partial_{z^j} \partial_{\bar{z}^k} f)(u^j \bar{v}^k - \bar{u}^k v^j). \quad (3.9)$$

**Lemma 3.20.** *Suppose  $f : M \rightarrow \mathbb{R}$  is a smooth real valued function on the complex manifold  $M$  and  $p_0$  is a critical point of  $M$ . Denote by  $H$  the Hessian of  $f$  at  $p_0$ . We define the complex Hessian of  $f$  at  $p_0$  to be the  $\mathbb{R}$ -bilinear map*

$$C_f : T_{p_0}M \times T_{p_0}M \rightarrow \mathbb{R},$$

$$C_f(U, V) := H(U, V) + H(JU, JV), \quad \forall U, V \in T_{p_0}M.$$

Then

$$C_f(U, V) = \mathbf{i} \partial\bar{\partial}f(U, JV).$$

*Proof.* Fix complex coordinates  $(z^1, \dots, z^m)$  near  $p_0$  such that  $z^j(p_0) = 0$ . Set  $f_0 = f(p_0)$ . Near  $p_0$  we have a Taylor expansion

$$f(z) = f_0 + \frac{1}{2} \sum_{jk} (a_{jk} z^j z^k + b_{jk} \bar{z}^j \bar{z}^k + c_{jk} z^j \bar{z}^k) + \dots.$$

Since  $f$  is real valued, we deduce

$$b_{jk} = \bar{a}_{jk}, \quad c_{jk} = \bar{c}_{kj} = (\partial_{z^j} \partial_{\bar{z}^k} f)(0).$$

Given real vectors

$$U = \sum_j (u^j \partial_{z^j} + \bar{u}^j \partial_{\bar{z}^j}) \in T_{p_0}M, \quad V = \sum_k (v^k \partial_{z^k} + \bar{v}^k \partial_{\bar{z}^k}),$$

we set  $H(U) := H(U, U)$ , and we have

$$H(U) = \sum_{jk} (a_{jk} u^j u^k + b_{jk} \bar{u}^j \bar{u}^k + c_{jk} u^j \bar{u}^k).$$

Using the polarization formula

$$H(U, V) = \frac{1}{4} (H(U+V) - H(U-V))$$



we deduce

$$H(U, V) = \sum_{j,k} (a_{jk} u^j v^k + b_{jk} \bar{u}^j \bar{v}^k) + \frac{1}{2} \sum_{j,k} c_{jk} (u^j \bar{v}^k + \bar{u}^j v^k).$$

Using (3.7) we deduce

$$H(JU, JV) = - \sum_{j,k} (a_{jk} u^j v^k + b_{jk} \bar{u}^j \bar{v}^k) + \frac{1}{2} \sum_{j,k} c_{jk} (u^j \bar{v}^k + \bar{u}^j v^k),$$

so that

$$C_f(U, V) = H(U, V) + H(JU, JV) = \sum_{j,k} c_{jk} (u^j \bar{v}^k + \bar{u}^j v^k).$$

Using (3.7) again we conclude that

$$\begin{aligned} C(U, JV) &= \sum_{j,k} c_{jk} (-i u^j \bar{v}^k + i \bar{u}^j v^k) \\ &= -i \sum_{j,k} c_{jk} (u^j \bar{v}^k - \bar{u}^j v^k) \stackrel{(3.9)}{=} -i \partial \bar{\partial} f(U, V). \end{aligned}$$

Replacing  $V$  by  $-JV$  in the above equality we obtain the desired conclusion.  $\square$

**Lemma 3.21 (Pseudoconvexity).** *Consider the function*

$$f : \mathbb{C}^\nu \rightarrow \mathbb{R}, \quad f(\zeta) = \frac{1}{2} |\zeta|^2.$$

*Then for every  $q \in \mathbb{C}^\nu$  and every real tangent vector  $U \in T_q \mathbb{C}^\nu$  we have*

$$i(\partial \bar{\partial} f)_q(U, JU) = |U|^2.$$

*Proof.* We have

$$f = \frac{1}{2} \sum_k \zeta^k \bar{\zeta}^k, \quad \partial \bar{\partial} f = \frac{1}{2} \sum_k d\zeta^k \wedge d\bar{\zeta}^k.$$

If

$$U = \sum_k (u^k \partial_{\zeta^k} + \bar{u}^k \partial_{\bar{\zeta}^k}) \in T_q \mathbb{C}^\nu,$$

then

$$JU = i \sum_k (u^k \partial_{\zeta^k} - \bar{u}^k \partial_{\bar{\zeta}^k})$$

and

$$\begin{aligned}
(\partial\bar{\partial}f)_{p_0}(U, JU) &= \frac{1}{2} \sum_k d\zeta^k \wedge d\bar{\zeta}^k(U, JU) \\
&= \frac{1}{2} \sum_k \begin{vmatrix} d\zeta^k(U) & d\zeta^k(JU) \\ d\bar{\zeta}^k(U) & d\bar{\zeta}^k(JU) \end{vmatrix} \\
&= \frac{1}{2} \sum_k \left( d\zeta^k(U)d\bar{\zeta}^k(JU) - d\zeta^k(JU)d\bar{\zeta}^k(U) \right) \\
&= -i \sum_k u^k \bar{u}^k = -i|U|^2.
\end{aligned}$$

□

**Proof of Theorem 3.18** Let  $M \hookrightarrow \mathbb{C}^\nu$  be a Stein manifold of complex dimension  $m$  and suppose  $f : \mathbb{C}^\nu \rightarrow \mathbb{R}$ ,  $f(\zeta) = \frac{1}{2}|\zeta|^2$  restricts to a Morse function on  $M$ . Suppose  $p_0$  is a critical point of  $f|_M$  and denote by  $H$  the Hessian of  $f|_M$  at  $p_0$ . We want to prove that  $\lambda(f, p_0) \leq m$ . Equivalently, we have to prove that if  $S \subset T_{p_0}M$  is a real subspace such that the restriction of  $H$  to  $S$  is negative definite, then

$$\dim_{\mathbb{R}} S \leq m.$$

Denote by  $J : TM \rightarrow TM$  the associated almost complex structure. We will first prove that

$$S \cap JS = 0.$$

We argue by contradiction. Suppose that  $S \cap JS \neq 0$ . Then there exists  $U \in S \setminus 0$  such that  $JU \in S$ . Then

$$H(U, U) < 0, \quad H(JU, JU) < 0 \Rightarrow C_f(U, U) = H(U, U) + H(JU, JU) < 0.$$

Lemma 3.20 implies

$$0 > C_f(U, U) = i(\partial\bar{\partial}f|_M)_{p_0}(U, JU) = i(\partial\bar{\partial}f)_{p_0}(U, JU),$$

while the pseudoconvexity lemma implies

$$0 > i(\partial\bar{\partial}f)_{p_0}(U, JU) = |U|^2,$$

which is clearly impossible. Hence  $S \cap JS = 0$  and we deduce

$$2m = \dim_{\mathbb{R}} T_{p_0}M \geq \dim_{\mathbb{R}} S + \dim_{\mathbb{R}} JS = 2 \dim_{\mathbb{R}} S. \quad \square$$

Let us discuss a classical application of Theorem 3.18. Suppose that  $V \subset \mathbb{C}\mathbb{P}^\nu$  is a smooth complex submanifold of complex dimension  $m$  described as the zero set of a finite collection of homogeneous polynomials<sup>2</sup>

<sup>2</sup> By Chow's theorem, every complex submanifold of  $\mathbb{C}\mathbb{P}^\nu$  can be described in this fashion [GH, I.3].

$$Q_1, \dots, Q_r \in \mathbb{C}[z^0, \dots, z^\nu].$$

Consider a hyperplane  $H \subset \mathbb{C}P^\nu$ . Modulo a linear change in coordinates we can assume that it is described by the equation  $z^0 = 0$ . Its complement can be identified with  $\mathbb{C}^\nu$  with coordinates  $\zeta^k = \frac{z^k}{z^0}$ . Denote by  $M$  the complement of  $V_\infty := V \cap H$  in  $V$ ,

$$M = V \setminus V_\infty.$$

Let us point out that  $V_\infty$  need not be smooth. Notice that  $M$  is a submanifold of  $\mathbb{C}^\nu$  described as the zero set of the collection of polynomials

$$P_j(\zeta^1, \dots, \zeta^\nu) = Q_j(1, \zeta^1, \dots, \zeta^\nu),$$

and thus it is an affine algebraic submanifold of  $\mathbb{C}^\nu$ . In particular,  $M$  is a Stein manifold. By Theorem 3.18 we deduce

$$H_{m+k}(M, \mathbb{Z}) = 0, \quad \forall k > 0.$$

On the other hand, we have the Poincaré–Lefschetz duality isomorphism [Spa, Theorem 6.2.19]<sup>3</sup>

$$H_j(V \setminus V_\infty, \mathbb{Z}) \rightarrow H^{2m-j}(V, V_\infty; \mathbb{Z}),$$

and we deduce

$$H^{m-k}(V, V_\infty; \mathbb{Z}) = 0, \quad \forall k > 0.$$

The long exact sequence cohomological sequence of the pair  $(V, V_\infty)$ ,

$$\begin{aligned} \dots \rightarrow H^{m-k}(V, V_\infty; \mathbb{Z}) \rightarrow H^{m-k}(V, \mathbb{Z}) \rightarrow H^{m-k}(V_\infty; \mathbb{Z}) \xrightarrow{\delta} \\ \rightarrow H^{m-(k-1)}(V, V_\infty; \mathbb{Z}) \rightarrow \dots, \end{aligned}$$

implies that the natural morphism

$$H^{m-k}(V, \mathbb{Z}) \rightarrow H^{m-k}(V_\infty; \mathbb{Z})$$

is an isomorphism if  $k > 1$ , and it is an injection if  $k = 1$ . Note that

$$k > 1 \iff m - k < \frac{1}{2} \dim_{\mathbb{R}} V_\infty, \quad k = 1 \iff m - k = \frac{1}{2} \dim_{\mathbb{R}} V_\infty.$$

We have obtained the celebrated *Lefschetz hyperplane theorem*.

**Theorem 3.22 (Lefschetz).** *If  $V$  is a projective algebraic manifold and  $V_\infty$  is the intersection of  $V$  with a hyperplane, then the natural restriction morphism*

$$H^j(V, \mathbb{Z}) \rightarrow H^j(V_\infty, \mathbb{Z})$$

*is an isomorphism for  $j < \frac{1}{2} \dim_{\mathbb{R}} V_\infty$  and an injection for  $j = \frac{1}{2} \dim_{\mathbb{R}} V_\infty$ .  $\square$*

---

<sup>3</sup> This duality isomorphism does not require  $V_\infty$  to be smooth. Only  $V \setminus V_\infty$  needs to be smooth;  $V_\infty$  is automatically tautly embedded, since it is triangulable.

### 3.4 Symplectic Manifolds and Hamiltonian Flows

A *symplectic pairing* on a finite dimensional vector space  $V$  is, by definition, a nondegenerate skew-symmetric bilinear form  $\omega$  on  $V$ . The nondegeneracy means that the induced linear map

$$I_\omega : V \rightarrow V^*, \quad v \mapsto \omega(v, \bullet),$$

is an isomorphism. We will identify a symplectic pairing with an element of  $\Lambda^2 V^*$  called a *symplectic form*. A *symplectic space* is a pair  $(V, \omega)$  where  $V$  is a finite dimensional vector space and  $\omega$  a symplectic form on  $V$ .

Suppose  $\omega$  is a symplectic pairing on the vector space  $V$ . An *almost complex structure tamed* by  $\omega$  is an  $\mathbb{R}$ -linear operator  $J : V \rightarrow V$  such that  $J^2 = -\mathbb{1}_V$  and the bilinear form

$$g = g_{\omega, J} : V \times V \rightarrow \mathbb{R}, \quad g(u, v) = \omega(u, Jv)$$

is symmetric and positive definite. We denote by  $\mathcal{J}_\omega$  the space of almost complex structures tamed by  $\omega$ .

**Proposition 3.23.** *Suppose that  $(V, \omega)$  is a symplectic space. Then  $\mathcal{J}_\omega$  is a nonempty contractible subset of  $\text{End}(V)$ . In particular, the dimension of  $V$  is even,  $\dim V = 2n$ , and for every  $J \in \mathcal{J}_\omega$  there exists a  $g_{\omega, J}$ -orthonormal basis  $(e_1, f_1, \dots, e_n, f_n)$  of  $V$  such that*

$$Je_i = f_i, \quad Jf_i = -e_i, \quad \forall i \text{ and } \omega(u, v) = g(Ju, v), \forall u, v \in V.$$

We say that the basis  $(e_i, f_i)$  is adapted to  $\omega$ .

*Proof.* Denote by  $\mathcal{M}_V$  the space of Euclidean metrics on  $V$ , i.e., the space of positive definite, symmetric bilinear forms on  $V$ . Then  $\mathcal{M}_V$  is a contractible space.

Any  $h \in \mathcal{M}_V$  defines a linear isomorphism  $A_h : V \rightarrow V$  uniquely determined by

$$\omega(u, v) = h(A_h u, v).$$

We say that  $h$  is *adapted* to  $\omega$  if  $A_h^2 = -\mathbb{1}_V$ . We denote by  $\mathcal{M}_\omega$  the space of metrics adapted to  $\omega$ . We have thus produced a homeomorphism

$$\mathcal{M}_\omega \rightarrow \mathcal{J}_\omega, \quad h \mapsto A_h,$$

and it suffices to show that  $\mathcal{M}_\omega$  is nonempty and contractible. More precisely, we will show that  $\mathcal{M}_\omega$  is a retract of  $\mathcal{M}_V$ .

Fix a metric  $h \in \mathcal{M}_V$ . For every linear operator  $B : V \rightarrow V$  we denote by  $B^*$  the adjoint of  $B$  with respect to  $h$ . Since  $\omega$  is skew-symmetric, we have

$$A_h^* = -A_h.$$

Set  $T_h = (A_h^* A_h)^{1/2} = (-A_h^2)^{1/2}$ . Observe that  $A_h$  commutes with  $T_h$ . We define a new metric

$$\hat{h}(u, v) := h(T_h u, v) \iff h(u, v) = \hat{h}(T_h^{-1} u, v).$$

Then

$$\omega(u, v) = h(A_h u, v) = \hat{h}(T_h^{-1} A_h u, v) \implies A_{\hat{h}} = T_h^{-1} A_h.$$

We deduce that

$$A_{\hat{h}}^2 = T_h^{-2} A_h^2 = -\mathbb{1}_V,$$

so that  $\hat{h} \in \mathcal{M}_\omega$  and therefore  $\mathcal{M}_\omega \neq \emptyset$ . Now observe that  $\hat{h} = h \iff h \in \mathcal{M}_\omega$ . This shows that the correspondence  $h \mapsto \hat{h}$  is a retract of  $\mathcal{M}_V$  onto  $\mathcal{M}_\omega$ .  $\square$

If  $\omega$  is a symplectic pairing on the vector space  $V$  and  $(e_i, f_i)$  is a basis of  $V$  adapted to  $\omega$ , then

$$\omega = \sum_i e^i \wedge f^i,$$

where  $(e^i, f^i)$  denotes the dual basis of  $V^*$ . Observe that

$$\frac{1}{n!} \omega^n = e^1 \wedge f^1 \wedge \cdots \wedge e^n \wedge f^n.$$

**Definition 3.24.** (a) A symplectic structure on a smooth manifold  $M$  is a 2-form  $\omega \in \Omega^2 T^*M$  satisfying

- $d\omega = 0$ .
- For every  $x \in M$  the element  $\omega_x \in \Lambda^2 T_x^*M$  is a symplectic pairing on  $T_x M$ .  
We will denote by  $I_\omega : TM \rightarrow T^*M$  the bundle isomorphism defined by  $\omega$  and we will refer to it as the symplectic duality.

(b) A symplectic manifold is a pair  $(M, \omega)$ , where  $\omega$  is a symplectic form on the smooth manifold  $M$ . A symplectomorphism of  $(M, \omega)$  is a smooth map  $f : M \rightarrow M$  such that

$$f^* \omega = \omega. \quad \square$$

Observe that if  $(M, \omega)$  is a symplectic manifold, then  $M$  must be even dimensional,  $\dim M = 2n$ , and the form  $dv_\omega := \frac{1}{n!} \omega^n$  is nowhere vanishing. We deduce that  $M$  is orientable. We will refer to  $dv_\omega$  as the *symplectic volume form*, and we will refer to the orientation defined by  $dv_\omega$  as the *symplectic orientation*. Note that if  $f : M \rightarrow M$  is symplectomorphism then

$$f^*(dv_\omega) = dv_\omega.$$

In particular,  $f$  is a *local diffeomorphism*.

**Example 3.25 (The standard model).** Consider the vector space  $\mathbb{C}^n$  with Euclidean coordinates  $z_j = x^j + iy^j$ . Then

$$\Omega = \sum_{j=1}^n dx^j \wedge dy^j = \frac{i}{2} \sum_{j=1}^n dz_j \wedge d\bar{z}_j = -\mathbf{Im} \sum_j dz^j \otimes d\bar{z}^j$$

defines a symplectic structure on  $\mathbb{C}^n$ . We will refer to  $(\mathbb{C}^n, \Omega)$  as the *standard model*.

Equivalently, the standard model is the pair  $(\mathbb{R}^{2n}, \Omega)$ , where  $\Omega$  is as above.  $\square$

**Example 3.26 (The classical phase space).** Suppose  $M$  is a smooth manifold. The *classical phase space*, denoted by  $\Phi(M)$ , is the total space of the cotangent bundle of  $M$ . The space  $\Phi(M)$  is equipped with a canonical symplectic structure. To describe it denote by  $\pi : \Phi(M) \rightarrow M$  the canonical projection. The differential of  $\pi$  is a bundle morphism

$$D\pi : T\Phi(M) \rightarrow \pi^*TM.$$

Since  $\pi$  is a submersion, we deduce that  $D\pi$  is surjective. In particular, its dual

$$(D\pi)^t : \pi^*T^*M \rightarrow T^*\Phi(M)$$

is injective, and thus we can regard the pullback  $\pi^*T^*M$  of  $T^*M$  to  $\Phi(M)$  as a subbundle of  $T^*\Phi(M)$ .

The pullback  $\pi^*T^*M$  is equipped with a tautological section  $\theta$  defined as follows. If  $x \in M$  and  $v \in T_x^*M$ , so that  $(v, x) \in \Phi(M)$ , then

$$\theta(v, x) = v \in T_x^*M = (\pi^*T^*M)_{(v, x)}.$$

Since  $\pi^*T^*M$  is a subbundle of  $T^*\Phi(M)$ , we can regard  $\theta$  as a 1-form on  $T^*M$ . We will refer to it as the *tautological 1-form* on the classical phase space.

If we choose local coordinates  $(x^1, \dots, x^n)$  on  $M$  we obtain a local frame  $(dx^1, \dots, dx^n)$  of  $T^*M$ . Any point in  $\varphi \in T^*M$  is described by the numbers  $(\xi_1, \dots, \xi_n, x^1, \dots, x^n)$ , where  $x = (x^i)$  are the coordinates of  $\pi(\varphi)$  and  $\sum \xi_i dx^i$  describes the vector in  $T_{\pi(\varphi)}^*M$  corresponding to  $\varphi$ . The tautological 1-form is described in the coordinates  $(\xi_i, x^j)$  by

$$\theta = \sum_i \xi_i dx^i.$$

Set  $\omega = -d\theta$ . Clearly  $\omega$  is closed. Locally,

$$\omega = \sum_i dx^i \wedge d\xi_i,$$

and we deduce that  $\omega$  defines a symplectic structure on  $\Phi(M)$ . The pair  $(\Phi(M), \omega)$  is called the *classical symplectic phase space*.

Let us point out a confusing fact. Suppose  $M$  is oriented, and the orientation is described locally by the  $n$ -form  $dx^1 \wedge \dots \wedge dx^n$ . This orientation induces

an orientation on  $T^*M$ , the *topologists orientation*  $\mathbf{or}_{top}$  described locally by the fiber-first convention

$$d\xi_1 \wedge \cdots \wedge d\xi_n \wedge dx^1 \wedge \cdots \wedge dx^n.$$

This can be different from the symplectic orientation  $\mathbf{or}_{symp}$  defined by

$$dx^1 \wedge d\xi_1 \wedge \cdots \wedge dx^n \wedge d\xi_n.$$

This discrepancy is encoded in the equality

$$\mathbf{or}_{top} = (-1)^{\frac{n(n+1)}{2}} \mathbf{or}_{symp}. \quad \square$$

**Example 3.27 (Kähler manifolds).** Suppose  $M$  is a complex manifold. A *Hermitian metric* on  $M$  is then a Hermitian metric  $h$  on the complex vector bundle  $TM^{1,0}$ . At every point  $x \in M$  the metric  $h$  defines a *complex valued*  $\mathbb{R}$ -bilinear map

$$h_x : T_x M^{1,0} \times T_x M^{1,0} \rightarrow \mathbb{C}$$

such that for  $X, Y \in T_x M^{1,0}$  and  $z \in \mathbb{C}$  we have

$$\begin{aligned} zh_x(X, Y) &= h_x(zX, Y) = h_x(X, \bar{z}Y), \\ h_x(Y, X) &= \overline{h_x(X, Y)}, \quad h_x(X, X) > 0, \quad \text{if } X \neq 0. \end{aligned}$$

We now have an isomorphism of *real* vector spaces  $T_x M \rightarrow T_x M^{1,0}$  given by

$$T_x M \ni X \mapsto X^{1,0} = \frac{1}{2}(X - iJX) \in T_x M^{1,0},$$

where  $J \in \text{End}(TM)$  denotes the almost complex structure determined by the complex structure. Now define

$$g_x, \omega_x : T_x M \times T_x M \rightarrow \mathbb{R}$$

by setting

$$g_x(X, Y) = \mathbf{Re} h_x(X^{1,0}, Y^{1,0}) \quad \text{and} \quad \omega_x(X, Y) = -\mathbf{Im} h_x(X^{1,0}, Y^{1,0}),$$

where  $g_x$  is symmetric and  $\omega_x$  is skew-symmetric. Note that

$$\begin{aligned} \omega_x(X, JX) &= -\mathbf{Im} h_x(X^{1,0}, (JX)^{1,0}) \\ &= -\mathbf{Im} h_x(X^{1,0}, iX^{1,0}) = \mathbf{Re} h_x(X^{1,0}, X^{1,0}). \end{aligned}$$

Thus  $\omega_x$  defines a symplectic pairing on  $T_x M$ , and the almost complex structure  $J$  is tamed by  $\omega_x$ .

Conversely, if  $\omega \in \Omega^2(M)$  is a nondegenerate 2-form tamed by the complex structure  $J$ , then we obtain a Hermitian metric on  $M$ .

A *Kähler manifold* is a complex Hermitian manifold  $(M, h)$  such that the associated 2-form  $\omega_h = -\mathbf{Im} h$  is symplectic.

By definition, a Kähler manifold is symplectic. Moreover, any *complex* submanifold of a Kähler manifold has an induced symplectic structure.

For example, the Fubini–Study form on the complex projective space  $\mathbb{C}\mathbb{P}^n$  defined in projective coordinates  $\mathbf{z} = [z_0, z_1, \dots, z_n]$  by

$$\omega = i\partial\bar{\partial} \log |\mathbf{z}|^2, \quad |\mathbf{z}|^2 = \sum_{k=0}^n |z_k|^2,$$

is tamed by the complex structure, and thus  $\mathbb{C}\mathbb{P}^n$  is a Kähler manifold. In particular, any complex submanifold of  $\mathbb{C}\mathbb{P}^n$  has a symplectic structure. The complex submanifolds of  $\mathbb{C}\mathbb{P}^n$  are precisely the projective algebraic manifolds, i.e., the submanifolds of  $\mathbb{C}\mathbb{P}^n$  defined as the zero sets of a finite family of homogeneous polynomials in  $n + 1$  complex variables.  $\square$

*Remark 3.28.* A symplectic structure on a manifold may seem like a skew-symmetric version of a Riemannian structure. As is well known, two Riemann structures can be very different locally. In particular, there exist Riemann metrics which cannot be rendered Euclidean in any coordinate system. The Riemann curvature tensor is essentially the main obstruction.

The symplectic situation is dramatically different. More precisely if  $(M^{2m}, \omega)$  is a symplectic manifold, then a theorem of Darboux shows that for any point  $p_0 \in M$  there exists local coordinates  $x_1, \dots, x_m, y_1, \dots, y_m$  on a neighborhood  $\mathcal{U}$  of  $p_0$  such that in these coordinates  $\omega$  has the canonical form

$$\omega|_{\mathcal{U}} = \sum_{k=1}^m dx_k \wedge dy_k.$$

For a proof of this and much more general results we refer to [Au, II.1.c].  $\square$

**Example 3.29 (Codajoint orbits).** To understand this example we will need a few basic facts concerning *homogeneous spaces*. For proofs and more information we refer to [Helg, Chapter II].

A smooth *right* action of a Lie group  $G$  on the smooth manifold  $M$  is a smooth map

$$M \times G \rightarrow M, \quad G \times M \ni (x, g) \mapsto R_g(x) := x \cdot g$$

such that

$$R_{\mathbf{1}} = \mathbb{1}_M, \quad (x \cdot g) \cdot h = x \cdot (gh), \quad \forall x \in M, \quad g, h \in G.$$

The action is called *effective* if  $R_g \neq \mathbb{1}_M, \forall g \in G \setminus \{\mathbf{1}\}$ .

Suppose  $G$  is a compact Lie group and  $H$  is a subgroup of  $G$  that is closed as a subset of  $G$ . Then  $H$  carries a natural structure of a Lie group such that  $H$  is a closed submanifold of  $G$ . The space  $H \backslash G$  of right cosets of  $H$  equipped with the quotient topology carries a natural structure of a smooth



manifold. Moreover, the right action of  $G$  on  $H \backslash G$  is smooth, transitive, and the stabilizer of each point is a closed subgroup of  $G$  conjugated to  $H$ .

Conversely, given a smooth and transitive right action of  $G$  on a smooth manifold  $M$ , then for every point  $m_0 \in M$  there exists a  $G$ -equivariant diffeomorphism  $M \rightarrow G_{m_0} \backslash G$ , where  $G_{m_0}$  denotes the stabilizer of  $m_0$ . Via this isomorphism the tangent space of  $M$  at  $m_0$  is identified with the quotient  $T_1G/T_1G_{m_0}$ .

Suppose  $G$  is a compact connected Lie group. We denote by  $\mathcal{L}_G$  the Lie algebra of  $G$ , i.e., the vector space of left invariant vector fields on  $G$ . As a vector space it can be identified with the tangent space  $T_1G$ . The group  $G$  acts on itself by conjugation,

$$C_g : G \rightarrow G, \quad h \mapsto ghg^{-1}.$$

Note that  $C_g(1) = 1$ . Denote by  $\text{Ad}_g$  the differential of  $C_g$  at 1. Then  $\text{Ad}_g$  is a linear isomorphism  $\text{Ad}_g : \mathcal{L}_G \rightarrow \mathcal{L}_G$ . The induced group morphism

$$\text{Ad} : G \rightarrow \text{Aut}_{\mathbb{R}}(\mathcal{L}_G), \quad g \mapsto \text{Ad}_g,$$

is called the *adjoint representation* of  $G$ . Observe that  $\text{Ad}_{gh}^* = \text{Ad}_h^* \circ \text{Ad}_g^*$ , and thus we have a *right action* of  $G$  on  $\mathcal{L}_G^*$

$$\mathcal{L}_G^* \times G \rightarrow \mathcal{L}_G^*, \quad (\alpha, g) \mapsto \alpha \cdot g := \text{Ad}_g^* \alpha.$$

This is called the *coadjoint action* of  $G$ .

For every  $X \in \mathcal{L}_G$  and  $\alpha \in \mathcal{L}_G^*$  we set

$$X^\sharp(\alpha) := \left. \frac{d}{dt} \right|_{t=0} \text{Ad}_{e^{tX}}^* \alpha \in T_\alpha \mathcal{L}_G^* = \mathcal{L}_G^*.$$

More explicitly, we have

$$\langle X^\sharp(\alpha), Y \rangle = \langle \alpha, [X, Y] \rangle, \quad \forall Y \in \mathcal{L}_G, \quad (3.10)$$

where  $\langle \bullet, \bullet \rangle$  is the natural pairing  $\mathcal{L}_G^* \times \mathcal{L}_G \rightarrow \mathbb{R}$ .

Indeed,

$$\langle X^\sharp(\alpha), Y \rangle = \left\langle \left. \frac{d}{dt} \right|_{t=0} \text{Ad}_{e^{tX}}^* (\alpha), Y \right\rangle = \left\langle \alpha, \left. \frac{d}{dt} \right|_{t=0} \text{Ad}_{e^{tX}} Y \right\rangle = \langle \alpha, [X, Y] \rangle.$$

For every  $\alpha \in \mathcal{L}_G^*$  we denote by  $\mathcal{O}_\alpha \subset \mathcal{L}_G^*$  the orbit of  $\alpha$  under the coadjoint action of  $G$ , i.e.,

$$\mathcal{O}_\alpha := \{ \text{Ad}_g^*(\alpha); \quad g \in G \}.$$

The orbit  $\mathcal{O}_\alpha$  is a compact subset of  $\mathcal{L}_G^*$ . Denote by  $G_\alpha$  the *stabilizer* of  $\alpha$  with respect to the coadjoint action,

$$G_\alpha := \{ g \in G; \quad \text{Ad}_g^*(\alpha) = \alpha \}.$$

The stabilizer  $G_\alpha$  is a Lie subgroup of  $G$ , i.e., a subgroup such that the subset  $G_\alpha$  is a closed submanifold of  $G$ . We denote by  $\mathcal{L}_\alpha$  its Lie algebra. The obvious map

$$G \rightarrow \mathcal{O}_\alpha, \quad g \mapsto \text{Ad}_g^*(\alpha),$$

is continuous and surjective, and it induces a homeomorphism from the space  $G_\alpha \backslash G$  of right cosets of  $G_\alpha$  (equipped with the quotient topology) to  $\mathcal{O}_\alpha$  given by

$$\Phi : G_\alpha \backslash G \ni G_\alpha \cdot g \mapsto \text{Ad}_g^*(\alpha) \in \mathcal{O}_\alpha.$$

For every  $g \in G$  denote by  $[g]$  the left coset  $G_\alpha \cdot g$ . The quotient  $G_\alpha \backslash G$  is a smooth manifold, and the induced map

$$\Phi : G_\alpha \backslash G \rightarrow \mathcal{L}_G^*$$

is a smooth *immersion*, because the differential at the point  $[1] \in G_\alpha \backslash G$  is injective. It follows that  $\mathcal{O}_\alpha$  is a smooth submanifold of  $\mathcal{L}_G^*$ . In particular, the tangent space  $T_\alpha \mathcal{O}_\alpha$  can be canonically identified with a subspace of  $\mathcal{L}_G^*$ .

Set

$$\mathcal{L}_\alpha^\perp := \{ \beta \in \mathcal{L}_G^*; \langle \beta, X \rangle = 0, \quad \forall X \in \mathcal{L}_\alpha \}.$$

We claim that

$$T_\alpha \mathcal{O}_\alpha = \mathcal{L}_\alpha^\perp.$$

Indeed, let  $\dot{\beta} \in T_\alpha \mathcal{O}_\alpha \subset \mathcal{L}_G^*$ . This means that there exists  $X = X_\beta \in \mathcal{L}_G$  such that

$$\dot{\beta} = \left. \frac{d}{dt} \right|_{t=0} \text{Ad}_{\exp(tX_\beta)}^* \alpha = X_\beta^\sharp(\alpha).$$

Using (3.10) we deduce that

$$\langle \dot{\beta}, Y \rangle = \langle \alpha, [X_\beta, Y] \rangle, \quad \forall Y \in \mathcal{L}_G.$$

On the other hand,  $\alpha$  is  $G_\alpha$ -invariant, so that

$$\begin{aligned} Z^\sharp(\alpha) &= 0, \quad \forall Z \in \mathcal{L}_\alpha \\ \stackrel{(3.10)}{\implies} \langle Z^\sharp(\alpha), X \rangle &= \langle \alpha, [Z, X] \rangle = 0, \quad \forall X \in \mathcal{L}_G, \quad \forall Z \in \mathcal{L}_\alpha. \end{aligned}$$

If we choose  $X = X_\beta$  in the above equality, we deduce

$$\langle \dot{\beta}, Z \rangle = \langle \alpha, [X_\beta, Z] \rangle, \quad \forall Z \in \mathcal{L}_{G_\alpha} \implies \dot{\beta} \in \mathcal{L}_\alpha^\perp.$$

This shows that  $T_\alpha \mathcal{O}_\alpha \subset \mathcal{L}_\alpha^\perp$ . The dimension count

$$T_\alpha \mathcal{O}_\alpha = \dim \mathcal{O}_\alpha = \dim G_\alpha \backslash G = \dim \mathcal{L}_G - \dim \mathcal{L}_\alpha = \dim \mathcal{L}_\alpha^\perp$$

implies

$$T_\alpha \mathcal{O}_\alpha = \mathcal{L}_\alpha^\perp.$$

The differential of  $\Phi : G_\alpha \backslash G \rightarrow \mathcal{O}_\alpha$  at  $[1]$  induces an isomorphism

$$\Phi_* : T_{[1]}G_\alpha \backslash G \rightarrow T_\alpha \mathcal{O}_\alpha$$

and thus a linear isomorphism

$$\Phi_* : T_{[1]}G_\alpha \backslash G = \mathcal{L}/\mathcal{L}_\alpha \longrightarrow \mathcal{L}_\alpha^\perp, \quad X \bmod \mathcal{L}_\alpha \mapsto X^\sharp(\alpha).$$

Observe that the vector space  $\mathcal{L}_\alpha^\perp$  is naturally isomorphic to the dual of  $\mathcal{L}_G/\mathcal{L}_\alpha$ . The above isomorphism is then an isomorphism  $(\mathcal{L}_\alpha^\perp)^* \rightarrow \mathcal{L}_\alpha^\perp$ . We obtain a nondegenerate bilinear pairing

$$\omega_\alpha : \mathcal{L}_\alpha^\perp \times \mathcal{L}_\alpha^\perp \rightarrow \mathbb{R}, \quad \omega_\alpha(\dot{\beta}, \dot{\gamma}) = \langle \dot{\beta}, \Phi_*^{-1}\dot{\gamma} \rangle.$$

Equivalently, if we write

$$\dot{\beta} = X_\beta^\sharp(\alpha), \quad \dot{\gamma} = X_\gamma^\sharp(\alpha), \quad X_\beta, X_\gamma \in \mathcal{L}_G,$$

then

$$\omega_\alpha(\dot{\beta}, \dot{\gamma}) = \langle X_\beta^\sharp(\alpha), X_\gamma \rangle = \langle \alpha, [X_\beta, X_\gamma] \rangle. \quad (3.11)$$

Observe that  $\omega_\alpha$  is skew-symmetric, so that  $\omega_\alpha$  is a symplectic pairing. The group  $G_\alpha$  acts on  $T_\alpha \mathcal{O}_\alpha$  and  $\omega_\alpha$  is  $G_\alpha$ -invariant. Since  $G$  acts transitively on  $\mathcal{O}_\alpha$  and  $\omega_\alpha$  is invariant with respect to the stabilizer of  $\alpha$ , we deduce that  $\omega_\alpha$  extends to a  $G$ -invariant, nondegenerate 2-form  $\omega \in \Omega^2(\mathcal{O}_\alpha)$ . We want to prove that it is a symplectic form, i.e.,  $d\omega = 0$ .

Observe that the differential  $d\omega$  is also  $G$ -invariant and thus it suffices to show that

$$(d\omega)_\alpha = 0.$$

Let  $Y_i = X_i^\sharp(\alpha) \in T_\alpha \mathcal{O}_\alpha$ ,  $X_i \in \mathcal{L}_G$ ,  $i = 1, 2, 3$ . We have to prove that

$$(d\omega)_\alpha(Y_1, Y_2, Y_3) = 0.$$

We have the following identity [Ni1, Section 3.2.1]

$$\begin{aligned} d\omega(X_1, Y_2, Y_3) &= Y_1\omega(Y_2, Y_3) - Y_2\omega(Y_3, Y_1) + Y_3\omega(Y_1, Y_2) \\ &\quad + \omega(Y_1, [Y_2, Y_3]) - \omega(Y_2, [Y_3, Y_1]) + \omega(Y_3, [Y_1, Y_2]). \end{aligned}$$

Since  $\omega$  is  $G$ -invariant we deduce

$$\omega(Y_i, Y_j) = \text{const} \quad \forall i, j,$$

so the first row in the above equality vanishes. On the other hand, at  $\alpha$  we have the equality

$$\begin{aligned} &\omega(Y_1, [Y_2, Y_3]) - \omega(Y_2, [Y_3, Y_1]) + \omega(Y_3, [Y_1, Y_2]) \\ &= \langle \alpha, [X_1, [X_2, X_3]] - [X_2, [X_3, X_2]] + [Y_3, [X_1, X_2]] \rangle. \end{aligned}$$

The last term is zero due to the Jacobi identity. This proves that  $\omega$  is a symplectic form on  $\mathcal{O}_\alpha$ .

Consider the special case  $G = U(n)$ . Its Lie algebra  $\mathfrak{u}(n)$  consists of skew-Hermitian  $n \times n$  matrices and it is equipped with the Ad-invariant metric

$$(X, Y) = \mathbf{Re} \operatorname{tr}(XY^*).$$

This induces an isomorphism  $\mathfrak{u}(n)^* \rightarrow \mathfrak{u}(n)$ . The coadjoint action of  $U(n)$  on  $\mathfrak{u}(n)^*$  is given by

$$\operatorname{Ad}_T^*(X) = T^*XT = T^{-1}XT, \quad \forall T \in U(n), \quad \forall X \in \mathfrak{u}(n) \cong \mathfrak{u}(n)^*.$$

Fix  $S_0 \in \mathfrak{u}(n)$ . We can assume that  $S_0$  has the diagonal form

$$S_0 = S_0(\boldsymbol{\lambda}) = i\lambda_1 \mathbb{1}_{\mathbb{C}^{n_1}} \oplus \cdots \oplus i\lambda_k \mathbb{1}_{\mathbb{C}^{n_k}}, \quad \lambda_j \in \mathbb{R},$$

with  $n_1 + \cdots + n_k = n$  and the  $\lambda$ 's. The coadjoint orbit of  $S_0$  consists of all the skew-Hermitian matrices with the same spectrum as  $S_0$ , multiplicities included.

Consider a *flag* of subspaces of type  $\boldsymbol{\nu} := (n_1, \dots, n_k)$ , i.e. an increasing filtration  $\mathbb{F}$  of  $\mathbb{C}^n$  by complex subspaces

$$0 = V_0 \subset V_1 \subset \cdots \subset V_k = \mathbb{C}^n$$

such that  $n_j = \dim_{\mathbb{C}} V_j/V_{j-1}$ . Denote by  $P_j = P_j(\mathbb{F})$  the orthogonal projection onto  $V_j$ . We can now form the skew-Hermitian operator

$$A_{\boldsymbol{\lambda}}(\mathbb{F}) = \sum_j i\lambda_j (P_j - P_{j-1}).$$

Observe that the correspondence  $\mathbb{F} \mapsto A_{\boldsymbol{\lambda}}(\mathbb{F})$  is a bijection from the set of flags of type  $\boldsymbol{\nu}$  to the coadjoint orbit of  $S_0(\boldsymbol{\lambda})$ . We denote this set of flags by  $\mathbf{Fl}_{\mathbb{C}}(\boldsymbol{\nu})$ . The natural smooth structure on the coadjoint orbit induces a smooth structure on the set of flags. We will refer to this smooth manifold as the *flag manifold* of type  $\boldsymbol{\nu} := (n_1, \dots, n_k)$ . Observe that

$$\mathbf{Fl}_{\mathbb{C}}(1, n-1) = \mathbb{C}\mathbb{P}^{n-1},$$

$$\mathbf{Fl}_{\mathbb{C}}(k, n-k) = G_k(\mathbb{C}^n) = \text{the Grassmannian of } k\text{-planes in } \mathbb{C}^n.$$

The diffeomorphism  $A_{\boldsymbol{\lambda}}$  defines by pullback a  $U(n)$ -invariant symplectic form on  $\mathbf{Fl}_{\mathbb{C}}(\boldsymbol{\nu})$ , *depending on  $\boldsymbol{\lambda}$* . However, since  $U(n)$  acts transitively on the flag manifold, *this symplectic form is uniquely determined up to a multiplicative constant*.  $\square$

**Proposition 3.30.** *Suppose  $(M, \omega)$  is a symplectic manifold. We denote by  $\mathcal{J}_{M, \omega}$  the set of almost complex structures on  $M$  tamed by  $\omega$ , i.e., endomorphisms  $J$  of  $TM$  satisfying the following conditions*

- $J^2 = -\mathbb{1}_{TM}$ .

- The bilinear form  $g_{\omega, J}$  defined by

$$g(X, Y) = \omega(X, JY), \quad \forall X, Y \in \text{Vect}(M)$$

is a Riemannian metric on  $M$ .

Then the set  $\mathcal{J}_{\omega, M}$  is nonempty and the corresponding set of metrics  $\{g_{\omega, J}; J \in \mathcal{J}_{\omega, M}\}$  is a retract of the space of metrics on  $M$ .

*Proof.* This is a version of Proposition 3.23 for families of vector spaces with symplectic pairings. The proof of Proposition 3.23 extends word for word to this more general case.  $\square$

Suppose  $(M, \omega)$  is a symplectic manifold. Since  $\omega$  is nondegenerate, we have a bundle isomorphism  $I_\omega : TM \rightarrow T^*M$  defined by

$$\begin{aligned} \langle I_\omega X, Y \rangle = \omega(X, Y) &\iff \langle \alpha, Y \rangle = \omega(I_\omega^{-1} \alpha, Y), \\ \forall \alpha \in \Omega^1(M), \quad \forall X, Y \in \text{Vect}(M). \end{aligned} \quad (3.12)$$

One can give an alternative description of the symplectic duality.

For every vector field  $X$  on  $M$  we denote by  $X \lrcorner$  or  $i_X$  the *contraction* by  $X$ , i.e., the operation  $X \lrcorner : \Omega^\bullet(M) \rightarrow \Omega^{\bullet-1}(M)$  defined by

$$\begin{aligned} (X \lrcorner \eta)(X_1, \dots, X_k) &= \eta(X, X_1, \dots, X_k), \\ \forall X_1, \dots, X_k \in \text{Vect}(M), \quad \eta \in \Omega^{k+1}(M). \end{aligned}$$

Then

$$I_\omega = \bullet \lrcorner \omega \iff I_\omega X = X \lrcorner \omega, \quad \forall X \in \text{Vect}(M). \quad (3.13)$$

Indeed,

$$\langle I_\omega X, Y \rangle = \omega(X, Y) = (X \lrcorner \omega)(Y), \quad \forall Y \in \text{Vect}(M).$$

**Lemma 3.31.** *Suppose  $J$  is an almost complex structure tamed by  $\omega$ . Denote by  $g$  the associated Riemannian metric and by  $I_g : TM \rightarrow T^*M$  the metric duality isomorphism. Then*

$$I_\omega = I_g \circ J \iff I_\omega^{-1} = -J \circ I_g^{-1}. \quad (3.14)$$

*Proof.* Denote by  $\langle \bullet, \bullet \rangle$  the natural pairing between  $T^*M$  and  $TM$ . For any  $X, Y \in \text{Vect}(M)$  we have

$$\langle I_\omega X, Y \rangle = \omega(X, Y) = g(JX, Y) = \langle I_g(JX), Y \rangle$$

so that  $I_\omega = I_g \circ J$ .  $\square$

For every vector field  $X$  on  $M$  we denote by  $\Phi_t^X$  the (local) flow it defines. We have the following result.

**Proposition 3.32.** *Suppose  $X \in \text{Vect}(M)$ . The following statements are equivalent:*

- (a)  $\Phi_t^X$  is a symplectomorphism for all sufficiently small  $t$ .
- (b) The 1-form  $I_\omega X$  is closed.

*Proof.* (a) is equivalent to  $L_X \omega = 0$ , where  $L_X$  denotes the Lie derivative along  $X$ . Using Cartan's formula  $L_X = di_X + i_X d$  and the fact that  $d\omega = 0$  we deduce

$$L_X \omega = di_X \omega = d(I_\omega X).$$

Hence  $L_X \omega = 0 \iff d(I_\omega X) = 0$ . □

**Definition 3.33.** *For every smooth function  $H : M \rightarrow \mathbb{R}$  we denote by  $\nabla^\omega H$  the vector field*

$$\nabla^\omega H := I_\omega^{-1}(dH). \quad (3.15)$$

*The vector field  $\nabla^\omega H$  is called the Hamiltonian vector field associated with  $H$ , or the symplectic gradient of  $H$ . The function  $H$  is called the Hamiltonian of  $\nabla^\omega H$ . The flow generated by  $\nabla^\omega H$  is called the Hamiltonian flow generated by  $H$ .* □

*Remark 3.34.* Note that the equality (3.15) is equivalent to

$$(\nabla^\omega H) \lrcorner \omega = dH. \quad (3.16)$$

□

Proposition 3.32 implies the following result.

**Corollary 3.35.** *A Hamiltonian flow on the symplectic manifold  $(M, \omega)$  preserves the symplectic forms, and thus it is a one-parameter group of symplectomorphisms.*

**Lemma 3.36.** *Suppose  $(M, \omega)$  is a symplectic manifold,  $J$  is an almost complex structure tamed by  $\omega$ , and  $g$  is the associated metric. Then for every smooth function  $H$  on  $M$  we have*

$$\nabla^\omega H = -J\nabla^g H, \quad (3.17)$$

where  $\nabla^g H$  denotes the gradient of  $H$  with respect to the metric  $g$ .

*Proof.* Using (3.14) we have

$$I_g \nabla^g H = dH = I_\omega \nabla^\omega H = I_g J \nabla^\omega H \implies J \nabla^\omega H = \nabla^g H. \quad \square$$

**Example 3.37 (The harmonic oscillator).** Consider the standard symplectic plane  $\mathbb{C}$  with coordinate  $z = q + ip$  and symplectic form  $\Omega = dq \wedge dp$ . Let

$$H(p, q) = \frac{1}{2m}p^2 + \frac{k}{2}q^2, \quad k, m > 0.$$

The standard complex structure  $J$  given by

$$J\partial_q = \partial_p, \quad J\partial_p = -\partial_q$$

is tamed by  $\Omega$ , and the associated metric is the canonical Euclidean metric  $g = dp^2 + dq^2$ . Then

$$\nabla^g H = \frac{p}{m}\partial_p + kq\partial_q, \quad \nabla^\Omega H = -J\nabla^g H = \frac{p}{m}\partial_q - kq\partial_p.$$

The flow lines of  $\nabla^\Omega H$  are obtained by solving the *Hamilton equations*

$$\begin{cases} \dot{q} = \frac{p}{m} \\ \dot{p} = -kq \end{cases}, \quad p(0) = p_0, \quad q(0) = q_0.$$

Note that  $m\ddot{q} = -kq$ , which is precisely the Newton equation of a *harmonic oscillator* with elasticity constant  $k$  and mass  $m$ . Furthermore,  $p = m\dot{q}$  is the *momentum* variable. The Hamiltonian  $H$  is the sum of the kinetic energy  $\frac{1}{2m}p^2$  and the potential (elastic) energy  $\frac{kq^2}{2}$ . If we set<sup>4</sup>  $\omega := \sqrt{\frac{k}{m}}$ , then we deduce

$$q(t) = q_0 \cos(\omega t) + \frac{p_0}{m\omega} \sin(\omega t), \quad p(t) = -q_0 m\omega \sin(\omega t) + p_0 \cos(\omega t).$$

The period of the oscillation is  $T = \frac{2\pi}{\omega}$ . The total energy  $H = \frac{1}{2m}p^2 + \frac{kq^2}{2}$  is conserved during the motion, so that all the trajectories of this flow are periodic and are contained in the level sets  $H = \text{const}$ , which are ellipses. The motion along these ellipses is *clockwise* and has constant angular velocity  $\omega$ . For more on the physical origins of symplectic geometry we refer to the beautiful monograph [Ar1].  $\square$

**Definition 3.38.** *Given two smooth functions  $f, g$  on a symplectic manifold  $(M, \omega)$  we define the Poisson bracket of  $f$  and  $g$  to be the Lie derivative of  $g$  along the symplectic gradient vector field of  $f$ . We denote it by  $\{f, g\}$ , so that<sup>5</sup>*

$$\{f, g\} := L_{\nabla^\omega f} g. \quad \square$$

We have an immediate corollary of the definition.

<sup>4</sup> The overuse of the letter  $\omega$  in this example is justified only by the desire to stick with the physicists' traditional notation.

<sup>5</sup> **Warning:** The existing literature does not seem to be consistent on the right choice of sign for  $\{f, g\}$ . We refer to [McS, Remark 3.3] for more discussions on this issue.

**Corollary 3.39.** *The smooth function  $f$  on the symplectic manifold  $(M, \omega)$  is conserved along the trajectories of the Hamiltonian flow generated by  $H \in C^\infty(M)$  if and only if  $\{H, f\} = 0$ .  $\square$*

**Lemma 3.40.** *If  $(M, \omega)$  is a symplectic manifold and  $f, g \in C^\infty(M)$  then*

$$\{f, g\} = -\omega(\nabla^\omega f, \nabla^\omega g), \quad \nabla^\omega \{f, g\} = [\nabla^\omega f, \nabla^\omega g]. \quad (3.18)$$

*In particular,  $\{f, g\} = -\{g, f\}$  and  $\{f, f\} = 0$ .*

*Proof.* Set  $X_f = \nabla^\omega f$ ,  $X_g = \nabla^\omega g$ . We have

$$\{f, g\} = dg(X_f) \stackrel{(3.12)}{=} \omega(I_\omega^{-1} dg, X_f) = -\omega(X_f, X_g).$$

For every smooth function  $u$  on  $M$  we set  $X_u := \nabla^\omega u$ . We have

$$X_{\{f, g\}}u = \{\{f, g\}, u\} = -\{u, \{f, g\}\} = -X_u\{f, g\} = X_u\omega(X_f, X_g).$$

Since  $L_{X_u}\omega = 0$ , we deduce

$$\begin{aligned} X_u\omega(X_f, X_g) &= \omega([X_u, X_f], X_g) + \omega(X_f, [X_u, X_g]) \\ &= -[X_u, X_f]g + [X_u, X_g]f = -X_uX_fg + X_fX_u g + X_uX_g f - X_gX_u f. \end{aligned}$$

The equality  $\{f, g\} = -\{g, f\}$  is equivalent to  $X_g f = -X_f g$ , and we deduce

$$\begin{aligned} X_{\{f, g\}}u &= -X_uX_fg + X_fX_u g + X_uX_g f - X_gX_u f \\ &= -2X_uX_fg - X_fX_g u + X_gX_f u = 2X_{\{f, g\}}u - [X_f, X_g]u. \end{aligned}$$

Hence

$$X_{\{f, g\}}u = [X_f, X_g]u, \quad \forall u \in C^\infty(M) \iff X_{\{f, g\}} = [X_f, X_g]. \quad \square$$

**Corollary 3.41 (Conservation of energy).** *Suppose  $(M, \omega)$  is a symplectic manifold and  $H$  is a smooth function. Then any trajectory of the Hamiltonian flow generated by  $H$  is contained in a level set  $H = \text{const}$ . In other words,  $H$  is conserved by the flow.*

*Proof.* Indeed,  $\{H, H\} = 0$ .  $\square$

**Corollary 3.42.** *The Poisson bracket defines a Lie algebra structure on the vector space of smooth functions on a symplectic manifold. Moreover, the symplectic gradient map*

$$\nabla^\omega : C^\infty(M) \rightarrow \text{Vect}(M)$$

*is a morphism of Lie algebras.*



*Proof.* We have

$$\begin{aligned} \{f, g\}, h\} + \{g, \{f, h\}\} &= X_{\{f, g\}}h + X_g X_f h = [X_f, X_g]h + X_g X_f h \\ &= X_f X_g h = \{f, \{g, h\}\}. \end{aligned}$$

□

**Example 3.43 (The standard Poisson bracket).** Consider the standard model  $(\mathbb{C}^n, \Omega)$  with coordinates  $z_j = q^j + ip_j$  and symplectic form  $\Omega = \sum_j dq^j \wedge dp_j$ . Then for every smooth function  $f$  on  $\mathbb{C}^n$  we have

$$\nabla^\Omega f = - \sum_j (\partial_{p_j} f) \partial_{q^j} + \sum_j (\partial_{q^j} f) \partial_{p_j},$$

so that

$$\{f, g\} = \sum_j \left( (\partial_{q^j} f) (\partial_{p_j} g) - (\partial_{p_j} f) (\partial_{q^j} g) \right). \quad \square$$

Suppose we are given a smooth *right* action of a Lie group  $G$  on a symplectic manifold  $(M, \omega)$ ,

$$M \times G \rightarrow M, \quad G \times M \ni (x, g) \mapsto R_g(x) := x \cdot g.$$

The action of  $G$  is called *symplectic* if  $R_g^* \omega = \omega, \forall g \in G$ .

Denote by  $\mathcal{L}_G$  the Lie algebra of  $G$ . Then for any  $X \in \mathcal{L}_G$  we denote by  $X^\flat \in \text{Vect}(M)$  the infinitesimal generator of the flow  $\Phi_t^X(z) = z \cdot e^{tX}, z \in M, t \in \mathbb{R}$ . We denote by  $\langle \bullet, \bullet \rangle$  the natural pairing  $\mathcal{L}_G^* \times \mathcal{L}_G \rightarrow \mathbb{R}$ .

**Definition 3.44.** A Hamiltonian action of the Lie group  $G$  on the symplectic manifold  $(M, \omega)$  is a smooth right symplectic action of  $G$  on  $M$  together with an  $\mathbb{R}$ -linear map

$$\xi : \mathcal{L}_G \rightarrow C^\infty(M), \quad \mathcal{L}_G \ni X \mapsto \xi_X \in C^\infty(M),$$

such that

$$\nabla^\omega \xi_X = X^\flat, \quad \{\xi_X, \xi_Y\} = \xi_{[X, Y]}, \quad \forall X, Y \in \mathcal{L}_G.$$

The induced map  $\mu : M \rightarrow \mathcal{L}_G^*$  defined by

$$\langle \mu(x), X \rangle := \xi_X(x), \quad \forall x \in M, \quad X \in \mathcal{L}_G,$$

is called the *moment map of the Hamiltonian action*. □

*Remark 3.45.* To any smooth left-action

$$G \times M \rightarrow M, \quad (g, p) \mapsto g \cdot p,$$

of the Lie group  $G$  on the smooth manifold we can associate in a canonical fashion a right action

$$M \times G \rightarrow M, (p, g) \mapsto p * g := g^{-1} \cdot p.$$

A left-action of a Lie group on a symplectic manifold will be called *Hamiltonian* if the associated right-action is such. This means that there exists an  $\mathbb{R}$ -linear map  $h : \mathcal{L}_G \rightarrow C^\infty(M)$ ,  $X \mapsto h_X$ , such that the flow  $p \mapsto e^{tX} \cdot p$  is the hamiltonian flow generated by  $h_X$  and

$$\{h_X, h_Y\} = -h_{[X, Y]}, \quad \forall X, Y \in \text{Vect}(M).$$

□

**Example 3.46 (The harmonic oscillator again).** Consider the action of  $S^1$  on  $\mathbb{C} = \mathbb{R}^2$  given by

$$\mathbb{C} \times S^1 \ni (z, e^{i\theta}) \mapsto z * e^{i\theta} := e^{-i\theta} z.$$

Using the computations in Example 3.37 we deduce that this action is Hamiltonian with respect to the symplectic form  $\Omega = dx \wedge dy = \frac{i}{2} dz \wedge d\bar{z}$ . If we identify the Lie algebra of  $S^1$  with the Euclidean line  $\mathbb{R}$  via the differential of the natural covering map  $t \mapsto e^{it}$ , then we can identify the dual of the Lie algebra with  $\mathbb{R}$ , and then the moment map of this action is  $\mu(z) = \frac{1}{2}|z|^2$ . □

**Lemma 3.47.** *Suppose we have a Hamiltonian action*

$$M \times G \rightarrow M, (x, g) \mapsto x \cdot g,$$

*of the compact connected Lie group  $G$  on the symplectic manifold  $(M, \omega)$ . Denote by  $\mu : M \rightarrow \mathcal{L}_G^*$  the moment map of this action. Then*

$$\mu(x \cdot g) = \text{Ad}_g^* \mu(x), \quad \forall g \in G, x \in M.$$

*Proof.* Set  $\xi_X = \langle \mu, X \rangle$ . Since  $G$  is compact and connected, it suffices to prove the identity for  $g$  of the form  $g = e^{tX}$ . Now observe that

$$(X^\flat \mu)(x) = \frac{d}{dt} \Big|_{t=0} \mu(x \cdot e^{tX}) \quad \text{and} \quad X^\sharp(\mu(x)) = \frac{d}{dt} \Big|_{t=0} \text{Ad}_{e^{tX}}^* \mu(x),$$

and we have to show that

$$(X^\flat \mu)(x) = X^\sharp(\mu(x)), \quad \forall X \in \mathcal{L}_G, x \in M.$$

For every  $Y \in \mathcal{L}_G$  we have

$$\begin{aligned} \frac{d}{dt} \Big|_{t=0} \langle \mu(x \cdot e^{tX}), Y \rangle &= X^\flat \cdot \langle \mu(x), Y \rangle = \{\xi_X, \xi_Y\} = \xi_{[X, Y]} \\ &= \langle \mu(x), [X, Y] \rangle \stackrel{(3.10)}{=} \langle X^\sharp(\mu(x)), Y \rangle. \end{aligned}$$

□

**Example 3.48 (Coadjoint orbits again).** Suppose  $G$  is a compact connected Lie group. Fix  $\alpha \in \mathcal{L}_G^* \setminus \{0\}$  and denote by  $\mathcal{O}_\alpha$  the coadjoint orbit of  $\alpha$ . Denote by  $\omega$  the natural symplectic structure on  $\mathcal{O}_\alpha$  described by (3.11). We want to show that the natural right action of  $G$  on  $(\mathcal{O}_\alpha, \omega)$  is Hamiltonian and that the moment map of this action  $\mu : \mathcal{O}_\alpha \rightarrow \mathcal{L}_G^*$  is given by

$$\mathcal{O}_\alpha \ni \beta \mapsto -\beta \in \mathcal{L}_G^*.$$

Let  $X \in \mathcal{L}_G$ . Set  $h = h_X : \mathcal{L}_G^* \rightarrow \mathbb{R}$ ,  $h(\beta) = -\langle \beta, X \rangle$ , where as usual  $\langle \bullet, \bullet \rangle$  denotes the natural pairing  $\mathcal{L}_G^* \times \mathcal{L}_G \rightarrow \mathbb{R}$ . In this case  $X^\sharp = X^\flat$ . We want to prove that

$$X^\sharp = \nabla^\omega h_X, \tag{3.19}$$

that is, for all  $\beta \in \mathcal{O}_\alpha$  and all  $\dot{\beta} \in T_\beta \mathcal{O}_\alpha$  we have

$$\omega(X^\sharp, \dot{\beta}) = dh_X(\dot{\beta}).$$

We can find  $Y \in \mathcal{L}_G$  such that  $\dot{\beta} = Y^\sharp(\beta)$ . Then using (3.11) we deduce

$$\omega(X^\sharp, \dot{\beta}) = \langle \beta, [X, Y] \rangle.$$

On the other hand,

$$dh_X(Y)|_\beta = -\frac{d}{dt}\Big|_{t=0} \langle \text{Ad}_{e^{tY}}^* \beta, X \rangle = -\frac{d}{dt}\Big|_{t=0} \langle \beta, \text{Ad}_{e^{tY}} X \rangle = \langle \beta, [X, Y] \rangle.$$

This proves that  $X^\sharp$  is the hamiltonian vector field determined by  $h_X$ . Moreover,

$$\{h_X, h_Y\}|_\beta = -\omega(X^\sharp, Y^\sharp)|_\beta = -\langle \beta, [X^\sharp, Y^\sharp] \rangle = h_{[X, Y]}(\beta).$$

This proves that the natural right action of  $G$  on  $G_\alpha$  is Hamiltonian with moment map  $\mu(\beta) = -\beta$ .  $\square$

**Proposition 3.49.** *Suppose we are given a Hamiltonian action of the compact Lie group  $G$  on the symplectic manifold. Then there exists a  $G$ -invariant almost complex structure tamed by  $\omega$ . We will say that  $J$  and its associated metric*

$$h(X, Y) = \omega(X, JY), \quad \forall X, Y \in \text{Vect}(M)$$

are  $G$ -tamed by  $\omega$ .

*Proof.* Fix an invariant metric on  $G$ , denote by  $dV_g$  the associated volume form, and denote by  $|G|$  the volume of  $G$  with respect to this volume form.

Note first that there exist  $G$ -invariant Riemannian metrics on  $M$ . To find such a metric, pick an arbitrary metric  $g$  on  $M$  and then form its  $G$ -average  $\hat{g}$ ,

$$\hat{g}(X, Y) := \frac{1}{|G|} \int_G u^* g(X, Y) dV_u, \quad \forall X, Y \in \text{Vect}(M).$$

By construction,  $\hat{g}$  is  $G$ -invariant. As in the proof of Proposition 3.23 define  $B = B_{\hat{g}} \in \text{End}(TM)$  by

$$\hat{g}(BX, Y) = \omega(X, Y), \quad \forall X, Y \in \text{Vect}(M).$$

Clearly  $B$  is  $G$ -invariant because  $\omega$  is  $G$ -invariant. Now define a new  $G$ -invariant metric  $h$  on  $M$  by

$$h(X, Y) := \hat{g}((B^*B)^{1/2}X, Y), \quad \forall X, Y \in \text{Vect}(M).$$

Then  $h$  defines a skew-symmetric almost complex structure  $J$  on  $TM$  by

$$\omega(X, Y) = h(JX, Y), \quad \forall X, Y \in \text{Vect}(M).$$

By construction  $J$  is a  $G$ -invariant almost complex structure tamed by  $\omega$ .  $\square$

**Example 3.50 (A special coadjoint orbit).** Suppose  $(M, \omega)$  is a compact oriented manifold with a Hamiltonian action of the compact Lie group  $G$ . Denote by  $\mu : M \rightarrow \mathcal{L}_G^*$  the moment map of this action. If  $\mathbb{T}$  is a subtorus of  $G$ , then there is an induced Hamiltonian action of  $\mathbb{T}$  on  $M$  with moment map  $\mu_{\mathbb{T}}$  obtained as the composition

$$M \xrightarrow{\mu} \mathcal{L}_G^* \twoheadrightarrow \mathfrak{t}^*,$$

where  $\mathcal{L}_G^* \twoheadrightarrow \mathfrak{t}^*$  denotes the natural projection obtained by restricting to the subspace  $\mathfrak{t}$  a linear function on  $\mathcal{L}_G$ .

Consider the projective space  $\mathbb{C}\mathbb{P}^n$ . As we have seen, for every  $\lambda \in \mathbb{R}^*$  we obtain a  $U(n+1)$ -equivariant identification of  $\mathbb{C}\mathbb{P}^n$  with a coadjoint orbit of  $U(n+1)$ . More precisely, this identification is given by the map

$$\Psi_{\lambda} : \mathbb{C}\mathbb{P}^n \rightarrow \mathfrak{u}(n+1), \quad \mathbb{C}\mathbb{P}^n \ni L \mapsto i\lambda P_L \in \mathfrak{u}(n+1),$$

where  $P_L$  denotes the unitary projection onto the complex line  $L$ , and we have identified  $\mathfrak{u}(n+1)$  with its dual via the Ad-invariant metric

$$(X, Y) = \mathbf{Re} \, \text{tr}(XY^*), \quad X, Y \in \mathfrak{u}(n+1).$$

We want to choose  $\lambda$  such that the natural complex structure on  $\mathbb{C}\mathbb{P}^n$  is adapted to the symplectic structure  $\Omega_{\lambda} = \Psi_{\lambda}^* \omega_{\lambda}$ , where  $\omega_{\lambda}$  is the natural symplectic structure on the coadjoint orbit  $\mathcal{O}_{\lambda} := \Psi_{\lambda}(\mathbb{C}\mathbb{P}^n)$ . Due to the  $U(n+1)$  equivariance, it suffices to check this at  $L_0 = [1, 0, \dots, 0]$ .

Note that if  $L = [z_0, \dots, z_n]$  then  $P_L$  is described by the Hermitian matrix  $(p_{jk})_{0 \leq j, k \leq n}$ , where

$$p_{jk} = \frac{1}{|\mathbf{z}|^2} z_j \bar{z}_k, \quad \forall 0 \leq j, k \leq n.$$

In particular,  $P_{L_0} = \text{Diag}(1, 0, \dots, 0)$ .

If  $L_t := [1, tz_1, \dots, tz_n] \in \mathbb{C}\mathbb{P}^n$ , then

$$\dot{P} = \frac{d}{dt}\Big|_{t=0} \Psi_\lambda(P_{L_t}) = \mathbf{i}\lambda \begin{bmatrix} 0 & \bar{z}_1 & \cdots & \bar{z}_n \\ z_1 & 0 & \cdots & 0 \\ \vdots & \vdots & \ddots & \vdots \\ z_n & 0 & \cdots & 0 \end{bmatrix}.$$

On the other hand, let  $X = (x_{ij})_{0 \leq i, j \leq n} \in \mathfrak{u}(n+1)$ . Then  $x_{ji} = -\bar{x}_{ij}$ ,  $\forall i, j$  and  $X$  defines a tangent vector  $X^\# \in T_{L_0} \mathcal{O}_\lambda$

$$X^\# := \mathbf{i}\lambda \frac{d}{dt}\Big|_{t=0} e^{-tX} P_{L_0} e^{tX} = -\mathbf{i}\lambda [P_{L_0}, X] = \mathbf{i}\lambda \begin{bmatrix} 0 & \bar{x}_{10} & \cdots & \bar{x}_{n0} \\ x_{10} & 0 & \cdots & 0 \\ \vdots & \vdots & \ddots & \vdots \\ x_{n0} & 0 & \cdots & 0 \end{bmatrix}.$$

These two computations show that if we identify  $X^\#$  with the column vector  $(x_{10}, \dots, x_{n0})^t$ , then the complex  $J$  structure on  $T_{L_0} \mathbb{C}\mathbb{P}^n$  acts on  $X^\#$  via the usual multiplication by  $\mathbf{i}$ .

Given  $X, Y \in \mathfrak{u}(n+1)$  we deduce from (3.11) that at  $L_0 \in \mathcal{O}_\lambda$  we have

$$\omega_\lambda(X^\#, Y^\#) = \mathbf{Re} \operatorname{tr}(\mathbf{i}\lambda P_{L_0} \cdot [X, Y]^*) = \lambda \mathbf{Im}[X, Y]_{0,0}^*,$$

where  $[X, Y]_{0,0}^*$  denotes the  $(0,0)$  entry of the matrix  $[X, Y]^* = [Y^*, X^*] = [Y, X] = -[X, Y]$ . We have

$$[X, Y]_{0,0} = \sum_{k=0}^n (x_{0k} y_{k0} - y_{0,k} x_{k0}) = - \sum_{k=1}^n (\bar{x}_{k0} y_{k0} - x_{k0} \bar{y}_{k0}).$$

Then

$$\omega(X^\#, JX^\#) = 2\lambda \sum_k |x_{0k}|^2$$

Thus, if  $\lambda$  is *positive*, then  $\Omega_\lambda$  is tamed by the canonical almost complex structure on  $\mathbb{C}\mathbb{P}^n$ . *In the sequel we will choose  $\lambda = 1$ .*

We thus have a Hamiltonian action of  $U(n+1)$  on  $(\mathbb{C}\mathbb{P}^n, \Omega_1)$ . The moment map  $\mu$  of this action is the opposite of the inclusion

$$\Psi_1 : \mathbb{C}\mathbb{P}^n \hookrightarrow \mathfrak{u}(n+1), \quad L \mapsto \mathbf{i}P_L,$$

so that

$$\mu(L) = -\Psi_1(L) = -\mathbf{i}P_L.$$

The *right* action of  $U(n+1)$  on  $\mathbb{C}\mathbb{P}^n$  is described by

$$\mathbb{C}\mathbb{P}^n \times U(n+1) \ni (L, T) \longmapsto T^{-1}L$$

because  $P_{T^{-1}L} = T^{-1}P_L T$ .

Consider now the torus  $\mathbb{T}^n \subset U(n+1)$  consisting of diagonal matrices of determinant equal to 1, i.e.,<sup>6</sup> matrices of the form

$$A(\mathbf{t}) = \text{Diag}(e^{-i(t_1+\dots+t_n)}, e^{it_1}, \dots, e^{it_n}), \quad \mathbf{t} = (t_1, \dots, t_n) \in \mathbb{R}^n.$$

Its action on  $\mathbb{C}\mathbb{P}^n$  is described in homogeneous coordinates by

$$[z_0, \dots, z_n]A(\mathbf{t}) = [e^{i(t_1+\dots+t_n)}z_0, e^{-it_1}z_1, \dots, e^{-it_n}z_n].$$

This action *is not effective* since the elements  $\text{Diag}(\zeta^{-n}, \zeta, \dots, \zeta)$ ,  $\zeta^{n+1} = 1$  act trivially. We will explain in the next section how to get rid of this minor inconvenience.

The Lie algebra  $\mathfrak{t}^n \subset \mathfrak{u}(n+1)$  of this torus can be identified with the vector space of skew-Hermitian diagonal matrices with trace zero.

We can identify the Lie algebra of  $\mathbb{T}^n$  with its dual using the Ad-invariant metric on  $\mathfrak{u}(n+1)$ . Under this identification the moment map of the action of  $\mathbb{T}^n$  is the map  $\hat{\mu}$  defined as the composition of the moment map

$$\mu : \mathbb{C}\mathbb{P}^n \rightarrow \mathfrak{u}(n+1)$$

with the orthogonal projection  $\mathfrak{u}(n+1) \rightarrow \mathfrak{t}^n$ . Since  $\text{tr } P_L = \dim_{\mathbb{C}} L = 1$  we deduce

$$\hat{\mu}(L) = -\text{Diag}(iP_L) + \frac{i}{n+1} \mathbb{1}_{\mathbb{C}^{n+1}},$$

where  $\text{Diag}(P_L)$  denotes the diagonal part of the matrix representing  $P_L$ . We deduce

$$\hat{\mu}([z_0, \dots, z_n]) = -\frac{i}{|\mathbf{z}|^2} \text{Diag}(|z_0|^2, \dots, |z_n|^2) + \frac{i}{n+1} \mathbb{1}_{\mathbb{C}^{n+1}}.$$

Thus the *opposite* action of  $\mathbb{T}^n$  given by

$$[z_0, \dots, z_n]A(\mathbf{t}) = [e^{-i(t_1+\dots+t_n)}z_0, e^{it_1}z_1, \dots, e^{it_n}z_n]$$

is also Hamiltonian, and the moment map is

$$\mu(L) = \frac{i}{|\mathbf{z}|^2} \text{Diag}(|z_0|^2, \dots, |z_n|^2) - \frac{i}{n+1} \mathbb{1}_{\mathbb{C}^{n+1}}.$$

We now identify the Lie algebra  $\mathfrak{t}^n$  with the vector space<sup>7</sup>

$$W := \left\{ \mathbf{w} = (w_0, \dots, w_n) \in \mathbb{R}^{n+1}; \sum_i w_i = 0 \right\}.$$

A vector  $\mathbf{w} \in W$  defines the Hamiltonian flow on  $\mathbb{C}\mathbb{P}^n$ ,

<sup>6</sup>  $\mathbb{T}^n$  is a maximal torus for the subgroup  $SU(n+1) \subset U(n+1)$ .

<sup>7</sup> In down-to-earth terms, we get rid of the useless factor  $i$  in the above formulæ.

$$e^{it} *_w [z_0, \dots, z_n] = [e^{iw_0 t} z_0, e^{iw_1 t} z_1, \dots, e^{iw_n t} z_n], \quad (3.20)$$

with the Hamiltonian function

$$\xi_{\mathbf{w}}([z_0, \dots, z_n]) = \frac{1}{|\mathbf{z}|^2} \sum_{j=0}^n w_j |z_j|^2. \quad (3.21)$$

The flow does not change if we add to  $\xi_{\mathbf{w}}$  a constant

$$c = \frac{c}{|\mathbf{z}|^2} \sum_{j=1}^n |z_j|^2.$$

Thus the Hamiltonian flow generated by  $\xi_{\mathbf{w}}$  is identical to the Hamiltonian flow generated by

$$f = \frac{1}{|\mathbf{z}|^2} \sum_{j=0}^n w'_j |z_j|^2, \quad w'_j = w_j + c.$$

Note that if we choose  $w'_j = j$  (so that  $c = \frac{n}{2}$ ), we obtain the perfect Morse function we discussed in Example 2.21. In the next two sections we will show that this “accident” is a manifestation of a more general phenomenon.  $\square$

**Example 3.51 (Linear hamiltonian action).** Suppose that  $(V, \omega)$  is a symplectic vector space and

$$V \times \mathbb{T} \rightarrow V, \quad (v, e^X) = v * e^X, \quad \forall v \in V, \quad X \in \mathfrak{t},$$

is a linear hamiltonian action of a  $k$ -dimensional torus  $\mathbb{T}$  on  $(V, \omega)$  with moment map  $\mu : V \rightarrow \mathfrak{t}^*$ .

Fix a  $\mathbb{T}$ -invariant almost complex structure  $J$  on  $V$  tamed by  $\omega$ , and denote by  $h$  the associated invariant inner product

$$h(v_1, v_2) = \omega(v_1, Jv_2), \quad v_1, v_2 \in V.$$

Denote by  $\mathfrak{so}_J(V)$  the space of skew-symmetric endomorphisms of  $V$  that commute with  $J$ . We can then find a linear map

$$A : \mathfrak{t} \rightarrow \mathfrak{so}_J(V), \quad X \mapsto A_X$$

such that for any  $v \in V$ ,  $X \in \mathfrak{t}$  we have

$$v * e^{tX} = e^{A_X t} v.$$

Note that  $A_X A_Y = A_Y A_X$ ,  $\forall X, Y \in \mathfrak{t}$ . We set  $B_X := J A_X$ . Note that  $B_X$  is a symmetric endomorphism that commutes with  $J$ . A simple computation shows that the moment map of this action is given by

$$\langle \mu(v), X \rangle = \frac{1}{2} h(B_X v, v), \quad \forall v \in V, \quad X \in \mathfrak{t}.$$

Because  $(B_X)_{X \in \mathfrak{t}}$  is a commutative family of symmetric operators we can find an orthonormal basis that diagonalizes all these operators.  $\square$

### 3.5 Morse Theory of Moment Maps

In this section we would like to investigate in greater detail the Hamiltonian actions of a torus

$$\mathbb{T}^n := \underbrace{S^1 \times \cdots \times S^1}_n$$

on a compact symplectic manifold  $(M, \omega)$ . As was observed by Atiyah in [A] the moment map of such an action generates many Morse–Bott functions. Following [A] we will then show that this fact alone imposes surprising constraints on the structure of the moment map. In the next section we will prove that these Morse–Bott functions are in fact *perfect*.

**Theorem 3.52.** *Suppose  $(M, \omega)$  is a connected symplectic manifold equipped with a Hamiltonian action of the torus  $\mathbb{T} = \mathbb{T}^n$ . Let  $\mu : M \rightarrow \mathfrak{t}^*$  be the moment map of this action, where  $\mathfrak{t}$  denotes the Lie algebra of  $\mathbb{T}$ . Then for every  $X \in \mathfrak{t}$  the function*

$$\xi_X : M \rightarrow \mathbb{R}, \quad \xi_X(x) = \langle \mu(x), X \rangle$$

*is a Morse–Bott function. The critical submanifolds are  $\mathbb{T}$ -invariant symplectic submanifolds of  $M$ , and all the Morse indices and coindices are even.*

*Proof.* Fix an almost complex structure  $J$  and metric  $h$  on  $TM$  that are equivariantly tamed by  $\omega$ .

For every subset  $A \subset \mathbb{T}$  we denote by  $\text{Fix}_A(M)$  the set of points in  $M$  fixed by all the elements in  $A$ , i.e.

$$\text{Fix}_A(M) = \{x \in M; \quad x \cdot a = x, \quad \forall a \in A\}.$$

**Lemma 3.53.** *Suppose  $G$  is a subgroup of  $\mathbb{T}$ . Denote by  $\bar{G}$  its closure. Then*

$$\text{Fix}_G(M) = \text{Fix}_{\bar{G}}(M)$$

*is a union of  $\mathbb{T}$ -invariant symplectic submanifolds of  $M$ .*

*Proof.* Clearly  $\text{Fix}_G(M) = \text{Fix}_{\bar{G}}(M)$ . Since  $\mathbb{T}$  is commutative, the set  $\text{Fix}_G(M)$  is  $\mathbb{T}$ -invariant. Let  $x \in \text{Fix}_G(M)$  and  $g \in G \setminus \{1\}$ . Denote by  $A_g$  the differential at  $x$  of the smooth map

$$M \ni y \mapsto y \cdot g \in M.$$

The map  $A_g$  is a unitary automorphism of the Hermitian space  $(T_x M, h, J)$ . Define

$$\text{Fix}_g(T_x M) := \ker(\mathbb{1} - A_g) \quad \text{and} \quad \text{Fix}_G(T_x M) = \bigcap_{g \in G} \text{Fix}_g(T_x M).$$

Consider the exponential map defined by the equivariantly tamed metric  $h$ ,



$$\exp_x : T_x M \rightarrow M.$$

Fix  $r > 0$  such that  $\exp_x$  is a diffeomorphism from  $\{v \in T_x M; |v|_h < r\}$  onto an open neighborhood of  $x \in M$ .

Since  $g$  is an isometry, it maps geodesics to geodesics and we deduce that  $\forall v \in T_x M$  such that  $|v|_h < r$  we have

$$(\exp_x(v)) \cdot g = \exp(A_g v).$$

Thus  $\exp(v)$  is a fixed point of  $g$  if and only if  $v$  is a fixed point of  $A_g$ , i.e.,  $v \in \text{Fix}_g(T_x M)$ . We deduce that the exponential map induces a homeomorphism from a neighborhood of the origin in the vector space  $\text{Fix}_G(T_x M)$  to an open neighborhood of  $x \in \text{Fix}_G(M)$ . This proves that  $\text{Fix}_G(M)$  is a submanifold of  $M$  and for every  $x \in \text{Fix}_G(M)$  we have

$$T_x \text{Fix}_G(M) = \text{Fix}_G(T_x M).$$

The subspace  $\text{Fix}_G(T_x M) \subset T_x M$  is  $J$ -invariant, which implies that  $\text{Fix}_G(M)$  is a symplectic submanifold.  $\square$

Let  $X \in \mathfrak{t} \setminus \{0\}$  and denote by  $G_X$  the one parameter subgroup

$$G_X = \{e^{tX} \in \mathbb{T}; t \in \mathbb{R}\}.$$

Its closure is a connected subgroup of  $\mathbb{T}$ , and thus it is a torus  $\mathbb{T}_X$  of positive dimension. Denote by  $\mathfrak{t}_X$  its Lie algebra. Consider the function

$$\xi_X(x) = \langle \mu(x), X \rangle, \quad x \in M.$$

**Lemma 3.54.**  $\text{Cr}_{\xi_X} = \text{Fix}_{\mathbb{T}_X}(M)$ .

*Proof.* Let  $X^\flat = \nabla^\omega \xi_X$ . From (3.17) we deduce

$$X^\flat = \nabla^\omega \xi_X = -J\nabla^h \xi_X.$$

This proves that  $x \in \text{Cr}_{\xi_X} \iff x \in \text{Fix}_{G_X}(M)$ .  $\square$

We can now conclude the proof of Theorem 3.52. We have to show that the components of  $\text{Fix}_{\mathbb{T}_X}(M)$  are nondegenerate critical manifolds.

Let  $C$  be a connected component of  $\text{Fix}_{\mathbb{T}_X}(M)$  and pick  $x \in C$ . As in the proof of Lemma 3.53, for every  $t \in \mathbb{R}$  we denote by  $A_t(X) : T_x M \rightarrow T_x M$  the differential at  $x$  of the smooth map

$$M \ni y \mapsto y \cdot e^{tX} =: \Phi_t^X(y) \in M.$$

Then  $A_t(X)$  is a unitary operator and

$$\ker(\mathbb{1} - A_t(X)) = T_x C, \quad \forall t \in \mathbb{R}.$$

We let

$$\dot{A}_X := \left. \frac{d}{dt} \right|_{t=0} A_t. \quad (3.22)$$

Then  $\dot{A}_X$  is a skew-hermitian endomorphism of  $(T_x M, J)$ , and we have

$$A_t(X) := e^{t\dot{A}_X} \quad \text{and} \quad T_x F = \ker \dot{A}.$$

Observe that

$$\dot{A}_X u = [U, X^\flat]_x, \quad \forall u \in T_x M, \quad \forall U \in \text{Vect}(M), \quad U(x) = u. \quad (3.23)$$

Indeed,

$$\dot{A}_X u = \left. \frac{d}{dt} \right|_{t=0} A_t(X) u = \left. \frac{d}{dt} \right|_{t=0} \left( (\Phi_t^X)_* U \right)_x = -(L_{X^\flat} U)_x = [U, X^\flat]_x.$$

Consider the Hessian  $H_x$  of  $\xi_X$  at  $x$ . For  $U_1, U_2 \in \text{Vect}(M)$  we set

$$u_i := U_i(x) \in T_x M,$$

and we have

$$H_x(u_1, u_2) = (U_1(U_2 \xi_X))|_x.$$

On the other hand,

$$\begin{aligned} U_1(U_2 \xi_X) &= U_1 d\xi_X(U_2) = U_1 \omega(X^\flat, U_2) \\ &= (L_{U_1} \omega)(X^\flat, U_2) + \omega([U_1, X^\flat], U_2) + \omega(X^\flat, [U_1, U_2]). \end{aligned}$$

At  $x$  we have

$$[U_1, X^\flat]_x = \dot{A} u_1, \quad X^\flat(x) = 0,$$

and we deduce

$$H_x(u_1, u_2) = \omega(\dot{A}_X u_1, u_2) = h(J \dot{A}_X u_1, u_2). \quad (3.24)$$

Now observe that  $B = J \dot{A}$  is a symmetric endomorphism of  $T_x M$  which commutes with  $J$ . Moreover,

$$\ker B = \ker \dot{A} = T_x C.$$

Thus  $B$  induces a symmetric linear isomorphism  $B : (T_x C)^\perp \rightarrow (T_x C)^\perp$ . Since it commutes with  $J$ , all its eigenspaces are  $J$ -invariant and in particular even-dimensional. This proves that  $C$  is a nondegenerate critical submanifold of  $\xi_X$ , and its Morse index is even, thus completing the proof of Theorem 3.52.  $\square$

Note the following corollary of the proof of Lemma 3.54.

**Corollary 3.55.** *Let  $X \in \mathfrak{t}$ . Then for every critical submanifold  $C$  of  $\xi_X$  and every  $x \in C$  we have*

$$T_x C = \{ u \in T_x M; \exists U \in \text{Vect}(M), [X^\flat, U]_x = 0, U(x) = u \},$$

where  $X^\flat = \nabla^\omega \xi_X$ . □

Suppose  $M, \mathbb{T}$  and  $\mu$  are as in Theorem 3.52. For every  $x \in M$  we denote by  $\mathbf{St}_x$  the stabilizer of  $x$ ,

$$\mathbf{St}_x := \{ g \in \mathbb{T}; x \cdot g = x \}.$$

Then  $\mathbf{St}_x$  is a *closed* subgroup of  $\mathbb{T}$ . The connected component of  $\mathbf{1} \in \mathbf{St}_x$  is a subtorus  $\mathbb{T}_x \subset \mathbb{T}$ . We denote by  $\mathfrak{t}_x$  its Lie algebra.

The differential of  $\mu$  defines for every point  $x \in M$  a linear map

$$\dot{\mu}_x : T_x M \rightarrow \mathfrak{t}^*.$$

We denote its transpose by  $\dot{\mu}_x^*$ . It is a linear map

$$\dot{\mu}_x^* : \mathfrak{t} \rightarrow T_x^* M.$$

Observe that for every  $X \in \mathfrak{t}$  we have

$$\dot{\mu}_x^*(X) = (d\xi_X)_x, \text{ where } \xi_X = \langle \mu, X \rangle : M \rightarrow \mathbb{R}. \quad (3.25)$$

**Lemma 3.56.** *For every  $x \in M$  we have  $\ker \dot{\mu}_x^* = \mathfrak{t}_x$ .*

*Proof.* From the equality (3.25) we deduce that  $X \in \ker \dot{\mu}_x^*$  if and only if  $d\langle \mu, X \rangle$  vanishes at  $x$ . Since  $X^\flat$  is the Hamiltonian vector field determined by  $\langle \mu, X \rangle$ , we deduce that

$$X \in \ker \dot{\mu}_x^* \iff X^\flat(x) = 0 \iff X \in T_{\mathbf{1}} \mathbf{St}_x = \mathfrak{t}_x. \quad \square$$

We say that a (right) action  $X \times G \rightarrow X, (g, x) \mapsto R_g(x) = x \cdot g$  of a group  $G$  on a set  $X$  is called *quasi-effective* if the kernel of the group morphism

$$G \ni g \mapsto R_{g^{-1}} \in \text{Diff}(M) = \text{the group of diffeomorphisms of } M$$

is finite.

**Lemma 3.57.** *If the Hamiltonian action of  $\mathbb{T}$  on  $M$  is quasi-effective, then the set of points  $x \in M$  such that  $\dot{\mu}_x : T_x M \rightarrow \mathfrak{t}^*$  is surjective is open and dense in  $M$ . In particular, the points in  $\mu(M)$  which are regular values of  $\mu$  form a dense subset of  $\mu(M)$ .*

*Proof.* Recall that an *integral weight* of  $\mathbb{T}$  is a vector  $w \in \mathfrak{t}$  such that

$$e^w = 1 \in \mathbb{T}.$$

The integral weights define a lattice  $L_{\mathbb{T}} \subset \mathfrak{t}$ . This means that  $L_{\mathbb{T}}$  is a discrete Abelian subgroup of  $\mathfrak{t}$  of rank equal to  $\dim_{\mathbb{R}} \mathfrak{t}$  such that the quotient  $\mathfrak{t}/L_{\mathbb{T}}$  is compact. Observe that we have a natural isomorphism of Abelian groups

$$L_{\mathbb{T}} \rightarrow \text{Hom}(S^1, \mathbb{T}), \quad L_{\mathbb{T}} \ni w \mapsto \varphi_w \in \text{Hom}(S^1, \mathbb{T}), \quad \varphi_w(e^{2\pi it}) = e^{tw}.$$

Any primitive<sup>8</sup> sublattice  $\Lambda$  of  $L_{\mathbb{T}}$  determines a closed subtorus  $\mathbb{T}_{\Lambda} := \{e^{tw}; w \in \Lambda\}$ , and any closed subtorus is determined in this fashion. This shows that there are at most countably many closed subtori of  $\mathbb{T}$ .

If  $\mathbb{T}' \subset \mathbb{T}$  is a nontrivial closed subtorus, then it acts quasi-effectively on  $M$ , and thus its fixed point set is a closed proper subset of  $M$  with dense complement. Baire's theorem then implies that

$$Z := M \setminus \bigcup_{\{1\} \neq \mathbb{T}' \subset \mathbb{T}} \text{Fix}_{\mathbb{T}'}(M) = \{z \in M; \mathfrak{t}_z = 0\}$$

is a dense subset of  $M$ . Lemma 3.56 shows that for any  $z \in Z$  the map

$$\dot{\mu}_z^* : \mathfrak{t} \rightarrow T_z^*M$$

is one-to-one, or equivalently that  $\dot{\mu}_z$  is onto. Clearly  $Z$  is open since submersiveness is an open condition.

We still have to prove that if  $\varphi \in \mu(M)$ , then there exists a sequence  $(\varphi_k) \subset \mu(M)$  such that,  $\forall k$ ,  $\varphi_k$  is a regular value of  $\mu$  and  $\lim_k \varphi_k = \varphi$ .

To show this fix  $x \in \mu^{-1}(\varphi)$ . Then there exists a sequence  $(x_k) \subset Z$  such that  $x_k \rightarrow x$ . Each  $x_k$  admits an open neighborhood  $U_k$  such that  $\mu(U_k)$  is an open subset of  $\mathfrak{t}^*$ . Invoking Sard's theorem we can find a regular value  $\varphi_k \in \mu(U_k)$  such that  $\text{dist}(\mu(x_k), \varphi_k) < \frac{1}{k}$ . It is now clear that

$$\lim_k \varphi_k = \lim_k \mu(x_k) = \varphi.$$

□

We have the following remarkable result of Atiyah [A] and Guillemin and Sternberg [GS] known as the *moment map convexity theorem*. It generalizes an earlier result of Frankel [Fra].

**Theorem 3.58 (Atiyah–Guillemin–Sternberg).** *Suppose we are given a quasi-effective Hamiltonian action of the torus  $\mathbb{T} = \mathbb{T}^n$  on the compact connected symplectic manifold  $(M, \omega)$ . Denote by  $\mu : M \rightarrow \mathfrak{t}^*$  the moment map of this action and by  $\{C_{\alpha}; \alpha \in \mathcal{A}\}$  the components of the fixed point set  $\text{Fix}_{\mathbb{T}}(M)$ . Then the following hold.*

<sup>8</sup> The sublattice  $\Lambda \subset L$  is called primitive if  $L/\Lambda$  is a free Abelian group.

- (a)  $\mu$  is constant on each component  $C_\alpha$ .
- (b) If  $\mu_\alpha \in \mathfrak{t}^*$  denotes the constant value of  $\mu$  on  $C_\alpha$ , then  $\mu(M) \subset \mathfrak{t}^*$  is the convex hull of the finite set  $\{\mu_\alpha; \alpha \in \mathcal{A}\} \subset \mathfrak{t}^*$ .

*Proof.* Lemma 3.56 shows that  $\mu$  is constant on the connected components  $C_\alpha$  of  $\text{Fix}_\mathbb{T}(M)$  because (the transpose of) its differential is identically zero along the fixed point set. There are finitely many components since these components are the critical submanifolds of a Morse–Bott function  $\xi_X$ , where  $X \in \mathbb{T}$  is such that  $\mathbb{T}_X = \mathbb{T}$ .

To prove the convexity statement we need to prove two things.

- (P<sub>1</sub>) The image  $\mu(M)$  is convex.
- (P<sub>2</sub>) The image  $\mu(M)$  is the convex hull of the finite set  $\{\mu_\alpha, \alpha \in \mathcal{A}\}$ .

**Proof of P<sub>1</sub>.** A key ingredient in the proof is the following topological result.

**Lemma 3.59 (Connectivity lemma).** *Suppose  $f : M \rightarrow \mathbb{R}$  is a Morse–Bott function on the compact connected manifold  $M$  such that Morse index and coindex of any critical submanifold are not equal to 1. Then for every  $c \in \mathbb{R}$  the level set  $\{f = c\}$  is connected or empty.* □

To keep the flow of arguments uninterrupted we will postpone the the proof of this result.

Fix an integral basis  $X_1, \dots, X_n$  of the weight lattice  $L_\mathbb{T}$ . For  $k = 1, 2, \dots, n$  we denote by  $\mathfrak{t}_k$  the subspace of  $\mathfrak{t}$  spanned by  $X_1, \dots, X_k$ . The space  $\mathfrak{t}_k$  is the Lie algebra of a  $k$ -dimensional torus  $\mathbb{T}_k \subset \mathbb{T}$ . Clearly

$$\mathfrak{t}_1 \subset \mathfrak{t}_2 \subset \dots \subset \mathfrak{t}_n = \mathfrak{t}.$$

We denote by  $\mu_k$  the moment map of the Hamiltonian action of  $\mathbb{T}_k$  on  $M$ ,

$$\mu_k : M \rightarrow \mathfrak{t}_k^*.$$

If we use the basis  $X_1, \dots, X_k$  of  $\mathfrak{t}_k$  to identify  $\mathfrak{t}_k$  with  $\mathbb{R}^k$ , then we can view  $\mu_k$  as a map  $M \rightarrow \mathbb{R}^k$ . More precisely

$$\mu_k(x) = (\xi_1(x), \dots, \xi_k(x)), \quad \forall x \in M,$$

where  $\xi_j = \xi_{X_j} = \langle \mu(x), X_j \rangle$  is the function with Hamiltonian vector field  $X_j^\flat$ .

Using the Connectivity Lemma 3.59 we deduce that all the fibers of the function

$$\mu_1 = \xi_1 : M \rightarrow \mathbb{R}$$

are connected. We want to prove by induction on  $k$  that the fibers of  $\mu_k$  are connected for any  $k = 1, \dots, n$ . More precisely we have the following result.

**Lemma 3.60.** *Let  $k = 1, \dots, n - 1$ . If the fibers of  $\mu_k$  are connected, then the fibers of  $\mu_{k+1}$  are also connected.*

*Proof.* We will prove that if  $\mathbf{t} = (t_1, \dots, t_k, t_{k+1}) \in \mu_{k+1}(M)$  is such that  $(t_1, \dots, t_k)$  is a regular value of  $\mu_k$ , then  $\mu_{k+1}^{-1}(\mathbf{t})$  is also connected. Consider the submanifold

$$Q := \mu_k^{-1}(t_1, \dots, t_k) \subset M.$$

We will prove that the restriction of  $\xi_{k+1}$  to  $Q$  satisfies all the properties of the Connectivity Lemma so that  $\mu_{k+1}^{-1}(\mathbf{t}) = \xi_{k+1}^{-1}(t_{k+1}) \cap Q$  is connected.

A point  $x \in Q$  is critical for  $\xi_{k+1}$  if and only if there exist Lagrange multipliers  $\lambda_1, \dots, \lambda_k \in \mathbb{R}$  such that

$$d\xi_{k+1}(x) + \sum_{j=1}^k \lambda_j d\xi_j(x) = 0.$$

In other words,  $x$  is a critical point of the function  $\xi_X$ , where

$$X = X_{k+1} + \sum_{j=1}^k \lambda_j X_j.$$

We know that  $\xi_X$  is a Morse-Bott function. Denote by  $C$  the critical set of  $\xi_X$  that contains  $x$ . Note that any  $y \in Q \cap C$  is a critical point of  $\xi_{k+1}|_Q$ . We will prove that  $C$  intersects  $Q$  transversally,

$$T_y M = T_y C + T_y Q, \quad \forall y \in C \cap Q. \quad (3.26)$$

We have to show that the restrictions of  $d\xi_1(y), \dots, d\xi_k(y)$  to  $T_y C$  are linearly independent.

To prove this observe that  $\xi_X$  Poisson commutes with all the functions  $\xi_1, \dots, \xi_k$ . Corollary 3.55 implies

$$X_1^\flat(y), \dots, X_k^\flat(y) \in T_y C.$$

On the other hand, the vectors  $X_1^\flat(y), \dots, X_k^\flat(y)$  are linearly independent, because differentials  $d\xi_1(y), \dots, d\xi_k(y)$  are such. Hence, for any  $\mathbf{s} = (s_1, \dots, s_k) \in \mathbb{R}^k \setminus 0$  we have

$$V(\mathbf{s}) = s_1 X_1^\flat(y) + \dots + s_k X_k^\flat(y) \in T_y C \setminus 0.$$

Since  $T_y C$  is a symplectic subspace of  $T_y M$ , we deduce that for any  $\mathbf{s} \in \mathbb{R}^k \setminus 0$  there exists  $U(\mathbf{s}) \in T_y C$  such that

$$0 \neq \omega(V(\mathbf{s}), U(\mathbf{s})) = \left\langle d\xi_{s_1 X_1 + \dots + s_k X_k}(y), U(\mathbf{s}) \right\rangle = \left\langle \sum_{j=1}^k s_j d\xi_j(y), U(\mathbf{s}) \right\rangle.$$

This proves (3.26), so that  $C \cap Q$  is a submanifold of  $Q$ . Observe that a complement  $W_x$  of  $T_x(C \cap Q)$  in  $T_x Q$  is also a complement of  $T_x C$  in  $T_x M$ . Thus the restriction of the Hessian of  $\xi_X$  to  $W_x$  is non degenerate and has even

index and coindex. Along  $Q$  the function  $\xi_{k+1}$  differs from  $\xi_X$  by an additive constant so the Hessian of  $\xi_X|_Q$  at  $x$  is equal to the Hessian of  $\xi_{k+1}|_Q$  at  $x$ . This proves that  $\xi_{k+1}|_Q$  is Morse-Bott with even indices and coindices. The Connectivity Lemma now implies that

$$\xi_{k+1}^{-1}(t_{k+1}) \cap Q = \mu_{k+1}(\mathbf{t})$$

is connected.

We have thus shown that  $\mu_{k+1}^{-1}(t_1, \dots, t_k, t_{k+1})$  is connected for any  $(t_1, \dots, t_k, t_{k+1}) \in \mu_{k+1}(M)$  such that  $(t_1, \dots, t_k)$  is a regular value of  $\mu_k$ . Since the action of  $\mathbb{T}_k$  is quasi-effective we deduce from Lemma 3.57 that  $\mu_{k+1}^{-1}(\mathbf{t})$  is connected for a dense set of  $\mathbf{t}$ 's in  $\mu_{k+1}$ . In particular, this shows that all the fibers of  $\mu_{k+1}$  connected. □

Since the basis  $X_1, \dots, X_n$  of  $L_{\mathbb{T}}$  was chosen arbitrarily, Lemma 3.60 shows that given any subtorus  $\mathbb{T}'$  of  $\mathbb{T}$  whose induced Hamiltonian action has moment map  $\mu'$ , the fibers of  $\mu'$  are connected.

For any primitive sublattice  $\Lambda$  of  $L_{\mathbb{T}}$  of dimension  $n - 1 = \dim \mathbb{T} - 1$  we obtain a subtorus  $\mathbb{T}_{\Lambda}$ . We denote by  $\mathfrak{t}_{\Lambda}$  its Lie algebra and by  $\mu_{\Lambda}$  its moment map  $\mu_{\Lambda} : M \rightarrow \mathfrak{t}_{\Lambda}^*$ . We have a natural projection

$$\pi_{\Lambda} : \mathfrak{t}^* \rightarrow \mathfrak{t}_{\Lambda}^*,$$

and  $\mu_{\Lambda} = \pi_{\Lambda} \circ \mu$ . Note that for any  $\varphi \in \mathfrak{t}_{\Lambda}^*$ , the fiber  $\pi_{\Lambda}^{-1}(\varphi)$  is an affine line  $\ell(\Lambda, \varphi) \subset \mathfrak{t}^*$ .

For any  $\varphi \in \mathfrak{t}_{\Lambda}^*$ , the fiber  $\mu_{\Lambda}^{-1}(\varphi)$  is a connected subset of  $M$ . Its image under  $\mu$  is then a connected subset of  $\mu(M)$  contained in the line  $\ell(\Lambda, \varphi) = \pi_{\Lambda}^{-1}(\varphi)$ . It is therefore a segment.

We thus proved that for any primitive lattice  $\Lambda \subset L_{\mathbb{T}}$  of codimension 1 and any  $\varphi \in \mathfrak{t}_{\Lambda}^*$ , the intersection of  $\mu(M)$  with the line  $\ell(\Lambda, \varphi)$  is a connected subset.

We denote by  $\mathbf{Graft}_1(\mathfrak{t}^*)$  the Grassmannian of affine lines in  $\mathfrak{t}^*$ . Consider the *incidence variety*

$$\mathcal{J}_M := \{(\eta, \ell) \in \mu(M) \times \mathbf{Graft}_1(\mathfrak{t}^*); \eta \in \ell\}.$$

This incidence variety is a *compact* subset of  $\mu(M) \times \mathbf{Graft}_1(\mathfrak{t}^*)$  and it is equipped with a natural projection

$$\pi : \mathcal{J}_M \rightarrow \mathbf{Graft}_1(\mathfrak{t}^*), \quad (\eta, \ell) \mapsto \ell.$$

The fiber of  $\pi$  over the line  $\ell \in \mathbf{Graft}_1(\mathfrak{t}^*)$  can be identified with the intersection  $\ell \cap \mu(M)$ .

The collection of lines  $\ell(\Lambda, \varphi)$ ,  $\Lambda$  primitive sublattice of codimension 1 and  $\varphi \in \mathfrak{t}_{\Lambda}^* = \text{Hom}(\Lambda, \mathbb{R})$  is a dense subset of  $\mathbf{Graft}_1(\mathfrak{t}^*)$ . Hence the fibers of  $\pi$  over the points of a dense subset are connected. Since  $\mathcal{J}_M$  is compact, we

deduce that all the fibers of  $\pi$  are connected. In other words, the intersection of  $\mu(M)$  with any affine line in  $\mathfrak{t}^*$  is a connected set, i.e.,  $\mu(M)$  is a convex set.

**Proof of P<sub>2</sub>.** Since we know that  $\mu(M)$  is convex, it suffices to show that if all the points  $\mu_\alpha$  lie on the same side of an affine hyperplane in  $\mathfrak{t}^*$ , then any other point  $\eta \in \mu(M)$  lies on the same side of that hyperplane.

Any hyperplane in  $\mathfrak{t}^*$  is determined by a vector  $X \in \mathfrak{t} \setminus 0$ , unique up to a multiplicative constant. Let  $X \in \mathfrak{t} \setminus 0$  and set

$$c_X = \min\{\langle \mu_\alpha, X \rangle; \alpha \in \mathcal{A}\}, \quad m_X = \min_{x \in X} \xi_X(x) = \min_{x \in M} \langle \mu(x), X \rangle.$$

We have to prove that  $m_X = c_X$ .

Clearly  $m_X \leq c_X$ . To prove the opposite inequality observe that  $m_X$  is a critical value of  $\xi_X$ . Since  $\xi_X$  is a Morse–Bott function we deduce that its lowest level set

$$\{x \in M; \xi_X(x) = m_X\}$$

is a union of critical submanifolds. Pick one such critical submanifold  $C$ .

If we could prove that  $C \cap \text{Fix}_{\mathbb{T}}(M) \neq \emptyset$ , then we could conclude that  $C_\alpha \subset C$  for some  $\alpha$  and thus  $c_X \leq m_X$ .

The submanifold  $C$  is a connected component of  $\text{Fix}_{\mathbb{T}_X}(M)$ . It is a symplectic submanifold of  $M$ , and the torus  $\mathbb{T}_\perp := \mathbb{T}/\mathbb{T}_X$  acts on  $C$ . Moreover,

$$\text{Fix}_{\mathbb{T}_\perp}(C) = C \cap \text{Fix}_{\mathbb{T}}(M),$$

so it suffices to show that

$$\text{Fix}_{\mathbb{T}_\perp}(C) \neq \emptyset.$$

Denote by  $\mathfrak{t}_\perp$  the Lie algebra of  $\mathbb{T}_\perp$  and by  $\mathfrak{t}_X$  the Lie algebra of  $\mathbb{T}_X$ . Observe that  $\mathfrak{t}_\perp^*$  is naturally a subspace of  $\mathfrak{t}^*$ , namely, the annihilator  $\mathfrak{t}_X^0$  of  $\mathfrak{t}_X$

$$\mathfrak{t}_\perp^* = \mathfrak{t}_X^0 := \{\nu \in \mathfrak{t}^*; \langle \nu, Y \rangle = 0, \forall Y \in \mathfrak{t}_X\}.$$

We will achieve this by showing that the action of  $\mathbb{T}_\perp$  on  $C$  is Hamiltonian.

Lemma 3.56 shows that for every  $Y \in \mathfrak{t}_X$  the restriction of  $\langle \mu, Y \rangle$  to  $C$  is a constant  $\varphi(Y)$  depending linearly on  $Y$ . In other words, it is an element  $\varphi \in \mathfrak{t}_X^*$ . Choose a linear extension  $\tilde{\varphi} : \mathfrak{t} \rightarrow \mathbb{R}$  of  $\varphi$  and set

$$\mu^\perp := \mu|_C - \tilde{\varphi}.$$

Observe that for every  $Y \in \mathfrak{t}_X$  we have  $\langle \mu^\perp, Y \rangle = 0$ , and thus  $\mu^\perp$  is valued in  $\mathfrak{t}_X^0 = \mathfrak{t}_\perp^*$ . For every  $Z \in \mathfrak{t}$  we have (along  $C$ )

$$\nabla^\omega \langle \mu, Z \rangle = \nabla^\omega \langle \mu^\perp, Z \rangle,$$

and we deduce that the action of  $\mathbb{T}_\perp$  on  $C$  is Hamiltonian with  $\mu^\perp$  as moment map.



Choose now a vector  $Z \in \mathfrak{t}_\perp$  such that the one-parameter group  $e^{tZ}$  is dense in  $\mathbb{T}_\perp$ . Lemma 3.54 shows that the union of the critical submanifolds of the Morse–Bott function  $\xi_Z^\perp = \langle \mu^\perp, Z \rangle$  on  $C$  is fixed point set of  $\mathbb{T}_\perp$ . In particular, a critical submanifold corresponding to the minimum value of  $\xi_Z^\perp$  is a connected component of  $\text{Fix}_{\mathbb{T}_\perp}(C)$ . This proves **P<sub>2</sub>**.

Let us observe that the above arguments imply the following result.

**Corollary 3.61.** *If  $\mathbb{T}$  acts quasi-effectively on  $M$  and  $X \in \mathfrak{t}$ , then the critical values of  $\xi_X$  are*

$$\{ \langle \mu_\alpha, X \rangle; \alpha \in \mathcal{A} \} = \langle \mu(\text{Fix}_{\mathbb{T}}(M)), X \rangle. \quad \square$$

**Proof of Lemma 3.59.** For  $c_1 < c_2$  we set

$$M_{c_1}^{c_2} = \{c_1 \leq f \leq c_2\}, \quad M^{c_2} = \{f \leq c_2\}, \quad M_{c_1} = \{f \geq c_1\}, \quad L_{c_1} = \{f = c_1\}.$$

For any critical submanifold  $S$  of  $f$  we denote by  $E_S^\pm$  (respectively  $E_S^-$ ) the stable (respectively unstable) part of the normal bundle of  $S$  spanned by eigenvectors of the Hessian corresponding to positive/negative eigenvalues. Denote by  $D_S^\pm$  the unit disk bundle of  $E_S^\pm$  with respect to some metric on  $E_S^\pm$ .

Since the Morse index and coindex of  $S$  are not equal to 1, we deduce that  $\partial D_S^\pm$  is connected. Thus, if we attach  $D_S^\pm$  to a compact  $CW$ -complex  $X$  along  $\partial D_S^\pm$ , then the resulting space will have the same number of *path* components as  $X$ .

Let  $f_{\min} := \min_{x \in M} f(x)$  and  $f_{\max} = \max_{x \in M} f(x)$ . Observe now that if  $\varepsilon > 0$  then  $\{f \leq f_{\min} + \varepsilon\}$  has the same number of connected components as  $\{f = f_{\min}\}$ .

Indeed, if  $C_1, \dots, C_k$  are the connected components of  $\{f = f_{\min}\}$ , then since  $f$  is a Morse–Bott function, we deduce that for  $\varepsilon > 0$  sufficiently small the sublevel set  $\{f \leq f_{\min} + \varepsilon\}$  is a disjoint union of tubular neighborhoods of the  $C_i$ 's.

The manifold  $M$  is homotopic to a space obtained from the sublevel set  $\{f \leq f_{\min} + \varepsilon\}$  via a finite number of attachments of the above type. Thus  $M$  must have the same number of components as  $\{f = f_{\min}\}$ , so that  $\{f = f_{\min}\}$  is path connected. We deduce similarly that for every regular value  $c$  of  $f$  the sublevel set  $M^c$  is connected. The same argument applied to  $-f$  shows that the level set  $\{f = f_{\max}\}$  is connected and the suprallevel sets  $M_c$  are connected.

To proceed further we need the following simple consequence of the above observations:

$$M_{c_1}^{c_2} \text{ is path connected if } L_{c_1} \text{ is path connected.} \quad (3.27)$$

Indeed, if  $p_0, p_1 \in M_{c_1}^{c_2}$ , then we can find a path connecting them inside  $M^{c_2}$ . If this path is not in  $M_{c_1}^{c_2}$ , then there is a first moment  $t_0$  when it intersects

$L_{c_1}$  and a last moment  $t_1$  when it intersects this level set. Now choose a path  $\beta$  in  $L_{c_1}$  connecting  $\gamma(t_0)$  to  $\gamma(t_1)$ . The path

$$p_0 \xrightarrow{\gamma} \gamma(t_0) \xrightarrow{\beta} \gamma(t_1) \xrightarrow{\gamma} p_1$$

is a path in  $M_{c_1}^{c_2}$  connecting  $p_0$  to  $p_1$ .

Consider the set

$$C := \{c \in [f_{\min}, f_{\max}]; L_{c'} \text{ is path connected } \forall c' \leq c\} \subset \mathbb{R}.$$

We want to prove that  $C = [f_{\min}, f_{\max}]$ .

Note first that  $C \neq \emptyset$  since  $f_{\min} \in C$ . Set  $c_0 = \sup C$ . We will prove that  $c_0 \in C$  and  $c_0 = f_{\max}$ .

If  $c_0$  is a regular value of  $f$ , then  $L_{c_0} \cong L_{c_0-\varepsilon}$  for all  $\varepsilon > 0$  sufficiently small, so that  $L_{c_0}$  is path connected and thus  $c_0 \in C$ .

Suppose  $c_0$  is a critical value of  $f$ . Since  $L_{c_0+\varepsilon}$  is path connected, we deduce from (3.27) that  $M_{c_0-\varepsilon}^{c_0+\varepsilon}$  is path connected for all  $\varepsilon > 0$ .

On the other hand, the level set  $L_{c_0}$  is a Euclidean neighborhood retract (see for example [Do, IV.8] or [Ha, Theorem A.7]), and we deduce (see [Do, VIII.6] or [Spa, Section 6.9]) that

$$\varinjlim_{\varepsilon} H^{\bullet}(M_{c_0-\varepsilon}^{c_0+\varepsilon}, \mathbb{Q}) = H^{\bullet}(L_{c_0}, \mathbb{Q}),$$

where  $H^{\bullet}$  denotes the *singular cohomology*.<sup>9</sup> Hence

$$H^0(L_{c_0}, \mathbb{Q}) = H^0(M_{c_0-\varepsilon}^{c_0+\varepsilon}, \mathbb{Q}) = \mathbb{Q}, \quad \forall 0 < \varepsilon \ll 1.$$

Hence  $L_{c_0}$  is path connected. This proves  $c_0 \in C$ .

Let us prove that if  $c_0 < f_{\max}$  then  $c_0 + \varepsilon \in C$ , contradicting the maximality of  $c_0$ . Clearly this happens if  $c_0$  is a regular value, since in this case  $L_{c_0+\varepsilon} \cong L_{c_0} \cong L_{c_0-\varepsilon}$ ,  $\forall 0 < \varepsilon \ll 1$ . Thus we can assume that  $c_0$  is a critical value.

Observe that since  $L_{c_0}$  is connected, then no critical submanifold of  $f$  in the level set  $L_{c_0}$  is a local maximum of  $f$ . Indeed, if  $S$  were such a critical submanifold then because  $f$  is Bott nondegenerate,  $S$  would be an isolated path component of  $L_{c_0}$  and thus  $L_{c_0} = S$ . On the other hand,  $M_{c_0}$  is path connected and thus one could find a path inside this region connecting a point on  $S$  to a point on  $\{f = f_{\max}\}$ . Since  $c_0 < f_{\max}$ , this would contradict the fact  $S$  is a local maximum of  $f$ .

We deduce that for any critical submanifold  $S$  in  $L_{c_0}$  the rank of  $E_S^+$  is at least 2, because it cannot be either zero or one. In particular, the Thom isomorphism theorem implies that

$$H^1(D_S^+, \partial D_S^+; \mathbb{Z}/2) = 0,$$

<sup>9</sup> The point of this emphasis is that only the singular cohomology  $H^0$  counts the number of *path* components. Other incarnations of cohomology count only components.

and this implies that

$$\begin{aligned} H^1(M_{c_0-\varepsilon}^{c_0+\varepsilon}, L_{c_0+\varepsilon}; \mathbb{Z}/2) &\cong H^1(M_{c_0-\varepsilon}, M_{c_0+\varepsilon}; \mathbb{Z}/2) \\ &\cong \bigoplus_S H^1(D_S^+, \partial D_S^+; \mathbb{Z}/2) = 0, \end{aligned}$$

where the summation is taken over all the critical submanifolds contained in the level set  $L_{c_0}$ , the first isomorphism is given by excision, and the second from the structural theorem Theorem 2.44. The long cohomological sequence of the pair  $(M_{c_0-\varepsilon}^{c_0+\varepsilon}, L_{c_0+\varepsilon})$  then implies that the morphism

$$H^0(M_{c_0-\varepsilon}^{c_0+\varepsilon}, \mathbb{Z}/2) \rightarrow H^0(L_{c_0+\varepsilon}, \mathbb{Z}/2)$$

is onto. Using (3.27) we deduce that  $H^0(M_{c_0-\varepsilon}^{c_0+\varepsilon}, \mathbb{Z}/2) = \mathbb{Z}/2$ , so that  $L_{c_0+\varepsilon}$  is path connected.  $\square$

The action of the torus near its fixed points is rather special. More precisely we have the following result.

**Theorem 3.62.** *Suppose  $(M, \omega)$  and  $\mathbb{T}$  are as in Theorem 3.58 and suppose that  $z$  is a fixed point of the  $\mathbb{T}$ -action. The symplectic form  $\omega$  on  $M$  defines a symplectic pairing  $\omega_z$  on  $T_z M$ . Then there exists a  $\mathbb{T}$ -invariant open neighborhood  $\mathcal{U}_0$  of  $0 \in T_z M$ , a  $\mathbb{T}$ -invariant open neighborhood  $\mathcal{U}_z$  of  $z \in M$  and a  $\mathbb{T}$ -equivariant diffeomorphism  $\Psi : \mathcal{U}_0 \rightarrow \mathcal{U}_z$  such that the following hold*

- $\Psi(0) = z$
- $\Psi^* \omega = \omega_z \in \Lambda^2 T_z^* M$ .
- For any  $X \in \mathfrak{t}$  and any  $u \in \mathcal{U}_0$  we have

$$\xi_X(\Psi(u)) = \xi_X(z) + \frac{1}{2} \omega_z(\dot{A}_X u, u) = \xi_X(z) + \frac{1}{2} h_z(J \dot{A}_X u, u),$$

where  $\dot{A}_X$  is defined as in (3.22).  $\square$

Loosely speaking, the above theorem states that near a fixed point of a hamiltonian torus action we can find local coordinates so that in these coordinates the action becomes a linear action of the type described in Example 3.51. For a proof of this theorem we refer to [Au, IV.4.d] or [GS, Thm. 4.1]. The deep fact behind this theorem is an equivariant version of the Darboux theorem, [Au, II.1.c].

The image of the moment map contains a lot of information about the action.

**Theorem 3.63.** *Let  $(M, \omega)$ ,  $\mu$  and  $\mathbb{T}$  be as above. Assume that  $\mathbb{T}$  acts effectively. Then the following hold.*

- (a) For any face  $F$  of the polyhedron  $\mu(M)$  we set

$$F^\perp := \{X \in \mathfrak{t}; \exists c \in \mathbb{R} : \langle \eta, X \rangle = c, \forall \eta \in F\}.$$

Observe that  $F^\perp$  is a vector subspace of  $\mathfrak{t}$  whose dimension equals the codimension of  $F$ . It is called the conormal space of the face  $F$ . Then for any face  $F$  of the convex polyhedron  $\mu(M)$  of positive codimension  $k$  the closed set

$$M_F := \mu^{-1}(F)$$

is a connected symplectic submanifold of  $M$  such that

$$\text{codim } M_F \geq 2 \text{ codim } F.$$

Moreover, if we set

$$\mathbf{St}_F := \{g \in \mathbb{T}; x \cdot g = x, \forall x \in M_F\},$$

then

$$T_1 \mathbf{St}_F = F^\perp.$$

(b)  $\dim M \geq 2 \dim \mathbb{T}$ .

(c) If  $\dim M = 2 \dim \mathbb{T}$ , then  $\text{codim } M_F = 2 \text{ codim } F$  for any face of  $\mu(M)$ .

*Proof.* Suppose  $F$  is a proper face of  $\mu(M)$  of codimension  $k > 0$ . Then there exists  $X \in \mathbb{T}$  which defines a proper supporting hyperplane for the face  $F$ , i.e.,

$$\langle \eta, X \rangle \leq \langle \eta', X \rangle, \quad \forall \eta \in F, \quad \eta' \in \mu(M),$$

with equality if and only if  $\eta' \in F$ . Consider then the Morse–Bott function  $\xi_X = \langle \mu, X \rangle$  and denote by  $m_X$  its minimum value on  $M$ . Then

$$M_F = \mu^{-1}(F) = \{\xi_X = m_X\}.$$

Lemma 3.59 shows that  $M_F$  is connected. It is clearly included in the critical set of  $\xi_X$ , so that  $M_F$  is a critical submanifold of  $\xi_X$ . It is thus a component of the fixed point set of  $\mathbb{T}_X$ .

Form the torus  $\mathbb{T}_F^\perp := \mathbb{T}/\mathbf{St}_F$  and denote by  $\mathfrak{t}_\perp$  its Lie algebra. Note that

$$\mathfrak{t}_F^\perp = \mathfrak{t}/\mathfrak{t}_F.$$

The dual of the Lie algebra  $\mathfrak{t}_F^\perp$  can be identified with a subspace of  $\mathfrak{t}^*$ , namely the annihilator  $\mathfrak{t}_F^0$  of  $\mathfrak{t}_F$ ,

$$\mathfrak{t}_F^0 := \{\eta \in \mathfrak{t}^*; \langle \eta, \mathfrak{t}_F \rangle = 0\} \subset \mathfrak{t}^*.$$

As in the proof of Theorem 3.58 we deduce that for every  $X \in \mathfrak{t}_F$  the function  $\langle \mu, X \rangle$  is constant along  $M_F$ . The action of  $\mathbb{T}_F^\perp$  on  $M_F$  is Hamiltonian, and as moment map we can take

$$\mu^\perp = \mu|_{M_F} - \varphi,$$

where  $\varphi$  is an arbitrary element in  $\mathfrak{t}^*$  satisfying

$$\langle \varphi, X \rangle = \langle \mu(z), X \rangle, \quad \forall z \in M_F, \quad X \in \mathfrak{t}_F.$$

Then

$$\mu^\perp(M_F) = F - \varphi \subset \mathfrak{t}_F^0 = (\mathfrak{t}_F^\perp)^*.$$

Since the action of  $\mathbb{T}_F^\perp$  on  $M_F$  is effective we deduce that that  $\mu^\perp(M_F)$  has nonempty interior in  $\mathfrak{t}_F^0$ . Thus, the relative interior of  $F - \varphi$  as a subset of  $\mathfrak{t}_F^0 \subset \mathfrak{t}^*$  is nonempty, and by duality we deduce that

$$F^\perp = (\mathfrak{t}_F^0)^0 = \mathfrak{t}_F.$$

This proves that  $\mathbb{T}_F$  is a torus of the same dimension as  $F^\perp$ , which is the codimension of  $F$ .

Let us prove that

$$\text{codim } M_F \geq 2 \text{codim } F = 2 \dim F^\perp.$$

Since the action of  $\mathbb{T}$  is effective, we deduce that the action of  $\mathbb{T}/\mathbf{St}_F$  on  $M_F$  is effective. Using Lemmas 3.57 and 3.56 we deduce that there exists a point  $z \in M_F$  such that its stabilizer with respect to the  $\mathbb{T}/\mathbf{St}_F$ -action is finite. This means that the stabilizer of  $z$  with respect to the  $\mathbb{T}$ -action is a closed subgroup whose identity component is  $\mathbb{T}_F$ , i.e.,  $\mathfrak{t}_z = \mathfrak{t}_F$ .

We set  $V_z := T_z M_F$  and we denote by  $E_z$  the orthogonal complement of  $V_z$  in  $T_z M$  with respect to a metric  $h$  on  $M$  equivariantly adapted to the Hamiltonian action as in the proof of Theorem 3.52. Then  $E_z$  is a complex Hermitian vector space. Let  $m := \dim_{\mathbb{C}} E_z$ , so that  $2m = \text{codim}_{\mathbb{R}} M_F$ . We will prove that

$$m \geq \dim F^\perp = \dim \mathbb{T}_F.$$

The torus  $\mathbb{T}_F$  acts unitarily on  $E_z$ , and thus we have a morphism

$$\mathbb{T}_F \ni g \rightarrow A_g \in U(m) = \text{Aut}(E_z, h).$$

We claim that its differential

$$\mathfrak{t}_F \ni X \rightarrow \dot{A}_X = \left. \frac{d}{dt} \right|_{t=0} A_{e^{tX}} \in \mathfrak{u}(m) = T_1 U(m)$$

is injective.

Indeed, let  $X \in \mathfrak{t}_F \setminus 0$ . Then  $z$  is a critical point of  $\xi_X$ . Denote by  $H_z$  the Hessian of  $\xi_Z$  at  $z$ . Arguing exactly as in the proof of (3.24) we deduce

$$H_z(u_1, u_2) = \omega(\dot{A}_X u_1, u_2) = h(J \dot{A}_X u_1, u_2), \quad \forall u_1, u_2 \in E_z.$$

Since  $\xi_X$  is a nonconstant Morse–Bott function, we deduce that  $H_z|_{E_z} \neq 0$ , and thus  $\dot{A}_X \neq 0$ . This proves the claim.

Thus the image  $\hat{\mathbb{T}}_F$  of  $\mathbb{T}_F$  in  $U(m)$  is a torus of the same dimension as  $\mathbb{T}_F$ , and since the maximal tori of  $U(m)$  have dimension  $m$  we deduce

$$\operatorname{codim} F = \dim \mathbb{T}_F \leq m = \frac{1}{2} \operatorname{codim}_{\mathbb{R}}(M_F).$$

If we apply (a) in the special case when  $F$  is a vertex of  $\mu(M)$  we deduce

$$\dim M - \dim M_F = \operatorname{codim} M_F \geq 2 \operatorname{codim} F = 2 \dim \mathbb{T}.$$

This proves (b). To prove (c) assume that  $\dim M = 2 \dim \mathbb{T}$ . We deduce. From the inequality

$$\dim M - \dim M_F \geq 2(\dim \mathbb{T} - \dim F)$$

we deduce

$$\dim M_F \leq 2 \dim F.$$

On the other hand, we have an effective hamiltonian action of the torus  $\mathbb{T}_F^\perp = \mathbb{T}/\mathbf{St}_F$  on  $M_F$  and thus

$$\dim M_F \geq 2 \dim \mathbb{T}_F^\perp = 2 \dim F.$$

**Theorem 3.64.** *Suppose  $(M, \omega)$  is equipped with a quasi-effective Hamiltonian action of the torus  $\mathbb{T}$  with moment map  $\mu : M \rightarrow \mathfrak{t}^*$ . Assume that*

$$\dim M = 2 \dim \mathbb{T} = 2m.$$

*Then any point  $\eta$  in the interior of  $\mu(M)$  is a regular value of  $\mu$ , the fiber  $\mu^{-1}(\eta)$  is connected and  $\mathbb{T}$ -invariant, and the stabilizer of every point  $z \in \mu^{-1}(\eta)$  is finite.*

*Proof.* Fix an invariant almost complex structure  $J$  tamed by  $\omega$  and denote by  $h$  the associated metric. Let  $\eta \in \operatorname{int} \mu(M)$  and  $z \in \mu^{-1}(\eta)$ . Denote by  $\mathbb{T}_z$  the identity component of  $\mathbf{St}_z$ . To prove that  $z$  is a regular point of  $\mu$  it suffices to show that  $\mathbf{St}_z$  is finite, i.e.,  $\mathbb{T}_z = 1$ . We follow the approach in [Del, Lemme 2.4]. We argue by contradiction and we assume that  $\ell := \dim \mathbb{T}_z > 0$ .

Choose a vector  $X_z \in \mathfrak{t}_z$ , the Lie algebra of  $\mathbb{T}_z$ , such that the 1-parameter subgroup  $\{e^{tX_z}\}_{t \in \mathbb{R}}$  is dense in  $\mathbb{T}_z$ . The point  $z$  is a critical point of the Morse-Bott function  $\xi_{X_z}(x) = \langle \mu(x), X_z \rangle$ . We denote by  $V_z$  the critical submanifold of  $\xi_{X_z}$  that contains  $z$ .

We have an effective hamiltonian action of the torus  $\mathbb{T}/\mathbb{T}_z$  on  $V_z$  so that

$$\dim V_z \geq 2 \dim \mathbb{T}/\mathbb{T}_z = 2(m - \ell).$$

In particular, the orthogonal complement  $T_z V_z^\perp$  of  $T_z V_z$  in  $T_z M_z$  has dimension  $2d \leq 2\ell$ .

The Lie algebra  $\mathfrak{t}_z$  of  $\mathbb{T}_z$  is a subalgebra of  $\mathfrak{t}$ , and thus we have a natural surjection  $\pi : \mathfrak{t}^* \rightarrow \mathfrak{t}_z^*$ . The action of  $\mathbb{T}_z$  on  $M$  is hamiltonian with moment map

$$\mu_z : M \xrightarrow{\mu} \mathfrak{t}^* \xrightarrow{\pi} \mathfrak{t}_z^*.$$

We have an action of  $\mathbb{T}_z$  on  $T_z M$

$$v * e^X = e^{\dot{A}_X} v, \quad \forall v \in T_z M, \quad X \in \mathfrak{t}_z,$$

where  $X \mapsto \dot{A}_X$  is a linear map  $\mathfrak{t}_z \rightarrow \mathfrak{so}_J(T_z M)$ , where we recall that  $\mathfrak{so}_J(T_z M)$  denotes the space of skew-symmetric endomorphisms of  $T_z M$  that commute with  $J$ . This action is trivial on the subspace  $T_z V_z \subset T_z M$ .

For  $X \in \mathfrak{t}_z$  we set  $B_X := J\dot{A}_X$ . Clearly  $B_X$  commutes with  $B_Y$  for any  $X, Y \in \mathfrak{t}_z$ . Thus the operators  $(B_X)_{X \in \mathfrak{t}_z}$  can be simultaneously diagonalized. Hence we can find an orthonormal basis

$$\mathbf{e}_1, \mathbf{e}_2, \dots, \mathbf{e}_{2m-1}, \mathbf{e}_{2m}$$

of  $T_z M$  and linear maps

$$w_1, \dots, w_d : \mathfrak{t}_z \rightarrow \mathbb{R}$$

such that

$$J\mathbf{e}_{2k-1} = \mathbf{e}_{2k}, \quad \forall k = 1, \dots, m,$$

$\mathbf{e}_1, \dots, \mathbf{e}_{2d}$  is an orthonormal basis of  $T_z V_z^\perp$ ,

$$B_X \mathbf{e}_{2k-1} = w_k(X) \mathbf{e}_{2k-1}, \quad B_X \mathbf{e}_{2k} = w_k(X) \mathbf{e}_{2k}, \quad \forall k = 1, \dots, d,$$

and

$$B_X \mathbf{e}_j = 0, \quad \forall j = 2d+1, \dots, 2m.$$

Using Theorem 3.62 we can find a  $\mathbb{T}_z$ -invariant neighborhood  $\mathcal{U}_0$  of  $0 \in T_z M$ , a  $\mathbb{T}_z$ -invariant neighborhood  $\mathcal{U}_z$  of  $z$  in  $M$  and a  $\mathbb{T}_z$ -equivariant diffeomorphism  $\Psi : \mathcal{U}_0 \rightarrow \mathcal{U}_z$  such that

$$\xi_X(\Psi(u)) = \mu_z(z) + \frac{1}{2} h(B_X u, u), \quad \forall X \in \mathfrak{t}_z, \quad u \in \mathcal{U}_0.$$

Fix a basis  $X_1, \dots, X_\ell$  of  $\mathfrak{t}_z$ , and denote by  $X_1^*, \dots, X_\ell^*$  the dual basis of  $\mathfrak{t}_z^*$ . Note that

$$w_k = \sum_{i=1}^{\ell} w_k(X_i) X_i^*, \quad \forall k = 1, \dots, d.$$

For any  $u \in T_z M$  and  $k = 1, \dots, m$  denote by  $u_k$  the component of  $u$  along the subspace spanned by  $\{\mathbf{e}_{2k-1}, \mathbf{e}_{2k}\}$ . We deduce that for any  $u \in \mathcal{U}_0$  we have

$$\begin{aligned} \mu_z(\Psi(u)) &= \sum_{i=1}^{\ell} \frac{1}{2} \left( \sum_{k=1}^d w_k(X_i) |u_k|^2 \right) X_i^* \\ &= \frac{1}{2} \sum_{k=1}^d |u_k|^2 \left( \sum_{i=1}^{\ell} w_k(X_i) X_i^* \right) = \frac{1}{2} \sum_{k=1}^d |u_k|^2 w_k. \end{aligned}$$

We deduce that the image of  $\mathcal{U}_z$  via the moment map  $\mu_z : M \rightarrow \mathfrak{t}_z^*$  is a neighborhood of  $\mu_z(z)$  in the affine cone

$$C_z = \mu_z(z) + C(w_1, \dots, w_k), \quad C(w_1, \dots, w_k) := \left\{ \sum_{k=1}^d s_k w_k; \quad s_k \geq 0 \right\} \subset \mathfrak{t}_z^*.$$

Since  $d \leq \ell$  we deduce that the cone  $C(w_1, \dots, w_d)$  is strictly contained in  $\mathfrak{t}_z^*$  and thus  $\mu_z(z)$  cannot be a point in the relative interior of  $\mu_z(M)$ . We reached a contradiction because

$$\mu_z(M) = \pi(\mu(M)),$$

and  $\mu_z(z) = \pi(\eta)$ , where  $\eta$  is in the relative interior of  $\mu(M)$ .

Hence  $\mu^{-1}(\eta)$  is a smooth submanifold of  $M$  of codimension equal to  $m = \dim \mathbb{T}$ . Lemma 3.60 shows that it is also connected. Choose a basis  $X_1, \dots, X_n$  of  $\mathfrak{t}$  such that for every  $i = 1, \dots, m$  the hyperplane

$$H_i := \{ \zeta \in \mathfrak{t}^*; \quad \langle \zeta, X_i \rangle = \eta_i := \langle \eta, X_i \rangle \}$$

does not contain<sup>10</sup> any of the vertices of  $\mu(M)$ . Corollary 3.61 shows that this condition is equivalent to the requirement that  $\eta_i$  be a regular value of  $\xi_i := \xi_{X_i}$ ,  $\forall i = 1, \dots, n$ . The fiber  $\mu^{-1}(\eta)$  is therefore the intersection of regular level sets of the functions  $\xi_i$ ,

$$\mu^{-1}(\eta) = \{ z \in M; \quad \xi_i(z) = \eta_i, \quad \forall i = 1, \dots, n \} = \bigcap_{i=1}^n \{ \xi_i = \eta_i \}.$$

Since  $\{\xi_i, \xi_j\} = 0$ ,  $\forall i, j$ , we deduce from Corollary 3.39 that  $\xi_i$  is constant along the trajectories of  $X_j^\flat = \nabla^\omega \xi_j$ . This proves that any intersection of level sets of  $\xi_i$ 's is a union of flow lines of *all* of the  $X_j^\flat$ 's. Hence  $\mu^{-1}(\eta)$  is connected and  $\mathbb{T}$ -invariant.  $\square$

**Definition 3.65.** *A toric symplectic manifold is a symplectic manifold  $(M, \omega)$  equipped with an effective Hamiltonian action of a torus of dimension  $\frac{1}{2} \dim M$ .*  $\square$

**Theorem 3.66.** *Suppose  $(M, \omega)$  is a toric symplectic manifold of dimension on  $2m$ . We denote by  $\mathbb{T}$  the  $m$ -dimensional torus acting on  $M$  and by  $\mu$  the moment map of this action. The the following hold:*

- (a) *For every face  $F$  of  $\mu(M)$  the submanifold  $M_F = \mu^{-1}(F)$  is a toric manifold of dimension  $2 \dim F$ .*
- (b) *For every  $\eta$  in the interior of  $\mu(M)$  the fiber  $M_\eta = \mu^{-1}(\eta)$  is diffeomorphic to  $\mathbb{T}$ .*

*Proof.* As in Theorem 3.63 we set

<sup>10</sup> The space of hyperplanes containing  $\eta$  and a vertex  $v$  of  $\mu(M)$  is rather “thin”. The normals of such hyperplanes must be orthogonal to the segment  $[\eta, v]$ , so that a generic hyperplane will not contain these vertices.



$$\mathbf{St}_F := \{g \in \mathbb{T}; \quad gx = x, \quad \forall x \in M_F\}.$$

Theorem 3.63 shows that  $\mathbf{St}_F$  is a closed subgroup of  $\mathbb{T}$  and

$$\dim \mathbf{St}_F = \text{codim } F = m - \dim F.$$

Thus  $\mathbb{T}_\perp = \mathbb{T}/\mathbf{St}_F$  is a torus of dimension  $M_F$  acting effectively on the symplectic manifold  $M_F$  of dimension  $2(m - k)$ .

For part (b) observe that  $M_\eta$  is a *connected*  $\mathbb{T}$ -invariant submanifold of  $M$  of dimension  $m$ . Let  $\mathcal{O}$  denote an orbit of  $\mathbb{T}$  on  $M_\eta$ . Then  $\mathcal{O}$  is a compact subset of  $M_\eta$ . Denote by  $G$  the stabilizer of a point in  $\mathcal{O}$ , so that

$$\mathcal{O} = \mathbb{T}/G.$$

On the other hand, by Theorem 3.64,  $G$  is a finite group, and since  $\dim \mathbb{T} = m = \dim M_\eta$ , we deduce that the orbit  $\mathcal{O}$  is an *open* subset of  $M_\eta$ . Hence  $\mathcal{O} = M_\eta$  because  $\mathcal{O}$  is also a *closed* subset of  $M_\eta$  and  $M_\eta$  is connected. The isomorphism  $\mathcal{O} = \mathbb{T}/G$  shows that  $M_\eta$  is a finite (free) quotient of  $\mathbb{T}$  so that  $M_\eta \cong \mathbb{T}$ . □

*Remark 3.67.* Much more is true. A result of T. Delzant [Del] shows that can show that the image of the moment map of a toric symplectic manifold completely determines the manifold, *uniquely* up to an equivariant symplectic diffeomorphism. □

**Example 3.68 (A toric structure on  $\mathbb{C}\mathbb{P}^2$ ).** Consider the action of the two torus  $\mathbb{T} = S^1 \times S^1$  on  $\mathbb{C}\mathbb{P}^2$  described in Example 3.50. More precisely, we have

$$\begin{aligned} [z_0, z_1, z_2] \cdot (e^{it_1}, e^{it_2}) &= [e^{-i(t_1+t_2)} z_0, e^{it_1} z_1, e^{it_2} z_2] \\ &= [z_0, e^{(2t_1+t_2)i} z_1, e^{(t_1+2t_2)i} z_2], \end{aligned} \tag{3.28}$$

with Hamiltonian function

$$\mu([z_0, z_1, z_2]) = \frac{1}{|\mathbf{z}|^2} (|z_0|^2, |z_1|^2, |z_2|^2) - \frac{1}{3}(1, 1, 1) \in \mathfrak{t}.$$

Set  $\mathbf{b} := \frac{1}{3}(1, 1, 1)$ .

This action is not effective because the subgroup

$$G = \{(\rho, \rho) \in \mathbb{T}; \quad \rho^3 = 1\} \cong \mathbb{Z}/3$$

acts trivially. To obtain an effective action we need to factor out this subgroup and look at the action of  $\mathbb{T}^2/G$ . We will do this a bit later.

The Lie algebra of  $\mathbb{T}$  is identified with the subspace

$$\mathfrak{t} = \{\mathbf{w} \in \mathbb{R}^3; \quad w_0 + w_1 + w_2 = 0\}.$$

The vector  $\mathbf{w} \in \mathfrak{t}$  generates the Hamiltonian flow

$$\Phi_t^\lambda([z_0, z_1, z_2]) = [e^{iw_0 t} z_0, e^{iw_1 t} z_1, e^{iw_2 t} z_2]$$

with Hamiltonian function

$$\xi_{\mathbf{w}} = \frac{w_0 |z_0|^2 + w_1 |z_1|^2 + w_2 |z_2|^2}{|\mathbf{z}|^2}.$$

We can now explain how to concretely factor out the action of  $G$ . This is done in two steps as follows.

**Step 1.** Construct a smooth surjective morphism of two dimensional tori  $\varphi : \mathbb{T} \rightarrow \mathbb{T}_0$  such that  $\ker \varphi = G$ .

**Step 2.** Define a new action of  $\mathbb{T}_0$  on  $\mathbb{C}\mathbb{P}^2$  by setting

$$[z_0, z_1, z_2] \cdot g = [z_0, z_1, z_2] \cdot \varphi^{-1}(g), \quad g \in \mathbb{T}_0,$$

where  $\varphi^{-1}(g)$  denotes an element  $h \in \mathbb{T}$  such that  $\varphi(h) = g$ . The choice of  $h$  is irrelevant since two different choices differ by an element in  $G$  which acts trivially on  $\mathbb{C}\mathbb{P}^2$ .

Step 1 does not have a unique solution, but formula (3.28) already suggests one. Define

$$\varphi : \mathbb{T} \rightarrow \mathbb{T}_0 = S^1 \times S^1, \quad \mathbb{T} \ni (e^{it_1}, e^{it_2}) \mapsto (e^{i(2t_1+t_2)}, e^{i(t_1+2t_2)}) \in \mathbb{T}_0.$$

To find its “inverse” it suffices to find the inverse of  $A = D\varphi|_1 : \mathfrak{t} \rightarrow \mathfrak{t}_0$ . Using the canonical bases of  $\mathbb{T}$  given by the identifications  $\mathbb{T} = S^1 \times S^1 = \mathbb{T}_0$  we deduce

$$A = \begin{bmatrix} 2 & 1 \\ 1 & 2 \end{bmatrix}, \quad A^{-1} = \frac{1}{3} \begin{bmatrix} 2 & -1 \\ -1 & 2 \end{bmatrix},$$

and

$$\mathbb{T}_0 \ni (e^{is_1}, e^{is_2}) \xrightarrow{\varphi^{-1}} \left( e^{i(2s_1-s_2)/3}, e^{i(-s_1+2s_2)/3} \right) \in \mathbb{T}.$$

The action of  $\mathbb{T}_0$  on  $\mathbb{C}\mathbb{P}^2$  is then given by

$$\begin{aligned} [z_0, z_1, z_2] \cdot (e^{is_1}, e^{is_2}) &= \left[ e^{-(s_1+s_2)i/3} z_0, e^{(2s_1-s_2)i/3} z_1, e^{(-s_1+2s_2)i/3} z_2 \right] \\ &= [z_0, e^{s_1 i} z_1, e^{s_2 i} z_2]. \end{aligned} \tag{3.29}$$

Note that

$$\mathfrak{t}_0 \ni \partial_{s_1} \xrightarrow{A^{-1}} \mathbf{w}_1 = \frac{1}{3} \left( -1, \underbrace{2, -1}_{\text{first column of } A^{-1}} \right) \in \mathfrak{t},$$

and

$$\mathfrak{t}_0 \ni \partial_{s_2} \xrightarrow{A^{-1}} \mathbf{w}_2 = \frac{1}{3} \left( -1, \underbrace{-1, 2}_{\text{second column of } A^{-1}} \right) \in \mathfrak{t}.$$

The vector  $\partial_{s_i}$  generates the Hamiltonian flow  $\Psi_t^i = \Phi_t^{\mathbf{w}^i}$  with Hamiltonian function  $\chi_i := \xi_{\mathbf{w}^i}$ . More explicitly,

$$\chi_1 = \frac{-|z_0|^2 + 2|z_1|^2 - |z_2|^2}{3|\mathbf{z}|^2}, \quad \chi_2 = \frac{-|z_0|^2 - |z_1|^2 + 2|z_2|^2}{3|\mathbf{z}|^2}.$$

Using the equality  $|\mathbf{z}|^2 = |z_0|^2 + |z_1|^2 + |z_2|^2$ , we deduce<sup>11</sup>

$$\chi_i = \frac{|z_i|^2}{|\mathbf{z}|^2} - \frac{1}{3}, \quad i = 1, 2.$$

We can thus take as moment map of the action of  $\mathbb{T}_0$  on  $\mathbb{C}\mathbb{P}^2$  the function

$$\nu([z_0, z_1, z_2]) = (\nu_1, \nu_2), \quad \nu_i = \chi_i + \frac{1}{3}$$

because the addition of a constant to a function changes neither the Hamiltonian flow it determines nor the Poisson brackets with other functions.

For the equality (3.29) we deduce that the fixed points of this action are

$$P_0 = [1, 0, 0], \quad P_1 = [0, 1, 0], \quad P_2 = [0, 0, 1].$$

Set  $\nu_i = \nu(P_i)$ , so that

$$\nu_0 = (0, 0), \quad \nu_1 = (1, 0), \quad \nu_2 = (0, 1).$$

The image of the moment map  $\mu$  is the triangle  $\Delta$  in  $\mathfrak{t}_0$  with vertices  $\nu_0\nu_1\nu_2$ . Denote by  $E_i$  the edge of  $\Delta$  opposite the vertex  $\nu_i$ . We deduce that  $\nu^{-1}(E_i)$  is the hyperplane in  $\mathbb{C}\mathbb{P}^2$  described by  $z_0 = 0$ .

As explained in Theorem 3.63, the line  $\ell_i$  through the origin of  $\mathfrak{t}$  and perpendicular to  $E_i$  generates a 1-dimensional torus  $\mathbb{T}_{E_i}$  and  $E_i = \text{Fix}_{\mathbb{T}_{E_i}}(\mathbb{C}\mathbb{P}^2)$ . We have

$$\mathbb{T}_{E_0} = \{(e^{si}, e^{si}); s \in \mathbb{R}\}, \quad \mathbb{T}_{E_1} = \{(1, e^{si}); s \in \mathbb{R}\}, \quad \mathbb{T}_{E_2} = \{(e^{si}, 1); s \in \mathbb{R}\}.$$

Observe that the complex manifold

$$X := \nu^{-1}(\text{int } \Delta) = \mathbb{C}\mathbb{P}^2 \setminus \left( \mu^{-1}(E_0) \cup \mu^{-1}(E_1) \cup \mu^{-1}(E_2) \right)$$

is biholomorphic to the complexified torus  $\mathbb{T}_0^c = \mathbb{C}^* \times \mathbb{C}^*$  via the  $\mathbb{T}_0$ -equivariant map

$$X \ni [z_0, z_1, z_2] \xrightarrow{\Phi} (\zeta_1, \zeta_2) = (z_1/z_0, z_2/z_0) \in \mathbb{C}^* \times \mathbb{C}^*.$$

For  $\rho = (\rho_1, \rho_2) \in \text{int } (\Delta)$  we have

$$\begin{aligned} \nu^{-1}(\rho) &= \{ [1, z_1, z_2] \in \mathbb{C}\mathbb{P}^2; |z_i|^2 = \rho_i(1 + |z_1|^2 + |z_2|^2) \} \\ &= \{ [1, z_2, z_2]; |z_i|^2 = r_i \}, \quad r_i = \frac{\rho_i(\rho_1 + \rho_2)}{1 - (\rho_1 + \rho_2)}. \end{aligned}$$

<sup>11</sup> Compare this result with the harmonic oscillator computations in Example 3.46.

This shows what happens to the fiber  $\nu^{-1}(\rho)$  as  $\rho$  approaches one of the edges  $E_i$ . For example, as  $\rho$  approaches the edge  $E_1$  given by  $\rho_1 = 0$ , the torus  $\nu^{-1}(\rho)$  is shrinking in one direction since the codimension one cycle  $|z_1|^2 = r_1$  on  $\nu^{-1}(\rho)$  degenerates to a point as  $\rho \rightarrow 0$ .  $\square$

### 3.6 $S^1$ -Equivariant Localization

The goal of this section is to prove that the Morse–Bott functions determined by the moment map of a Hamiltonian torus action are *perfect*. We will use the strategy in [Fra] based on a result of P. Conner (Corollary 3.85) relating the Betti numbers of a smooth manifold equipped with a smooth  $S^1$ -action to the Betti numbers of the fixed point set.

To prove Conner’s result we use the equivariant localization theorem of Atiyah and Bott [AB2] which will require a brief digression into  $S^1$ -equivariant cohomology. For simplicity we write  $H^\bullet(X) := H^\bullet(X, \mathbb{C})$  for any topological space  $X$ .

Denote by  $S^\infty$  the unit sphere in an infinite dimensional, separable, complex Hilbert space. It is well known (see e.g. [Ha, Example 1.B.3]) that  $S^\infty$  is contractible. Using the identification

$$S^1 = \{z \in \mathbb{C}; |z| = 1\}$$

we see that there is a tautological *right free* action of  $S^1$  on  $S^\infty$ . The quotient  $BS^1 := S^\infty/S^1$  is the infinite dimensional complex projective space  $\mathbb{C}P^\infty$ .

Its cohomology ring with complex coefficients is isomorphic to the ring of polynomials with complex coefficients in one variable of degree 2,

$$H^\bullet(BS^1) \cong \mathbb{C}[\tau], \quad \deg \tau = 2.$$

We obtain a principal  $S^1$ -bundle  $S^\infty \rightarrow BS^1$ . To any principal  $S^1$ -bundle  $S^1 \hookrightarrow P \twoheadrightarrow B$  and any linear representation  $\rho : S^1 \rightarrow \text{Aut}(\mathbb{C}) = \mathbb{C}^*$  we can associate a complex line bundle  $L_\rho \rightarrow B$  whose total space is given by the quotient

$$P \times_\rho \mathbb{C} = (P \times \mathbb{C})/S^1,$$

where the *right action* of  $S^1$  on  $P \times \mathbb{C}$  is given by

$$(p, \zeta) \cdot e^{i\varphi} := (p \cdot e^{i\varphi}, \rho(e^{-i\varphi})\zeta), \quad \forall (p, \zeta) \in P \times \mathbb{C}, \quad e^{i\varphi} \in S^1.$$

$L_\rho$  is called the *complex line bundle associated* with the principal  $S^1$ -bundle  $P \twoheadrightarrow B$  and the representation  $\rho$ . When  $\rho$  is the tautological representation given by the inclusion  $S^1 \rightarrow \mathbb{C}^*$  we will say simply that  $L$  is the *complex line bundle associated with the principal  $S^1$ -bundle*.

**Example 3.69.** Consider the usual action of  $S^1$  on  $S^{2n+1} \subset \mathbb{C}^{n+1}$ . The quotient space is  $\mathbb{C}\mathbb{P}^n$  and the  $S^1$ -bundle  $S^{2n+1} \rightarrow \mathbb{C}\mathbb{P}^n$  is called the *Hopf bundle*. Consider the identity morphism

$$\rho_1 : S^1 \rightarrow S^1 \subset \text{Aut}(\mathbb{C}), \quad e^{it} \mapsto e^{it}.$$

The associated line bundle

$$S^{2n+1} \times_{\rho_1} \mathbb{C} \rightarrow \mathbb{C}\mathbb{P}^n$$

can be identified with the tautological line bundle  $\mathbb{U}_n \rightarrow \mathbb{C}\mathbb{P}^n$ .

To see this, note that we have an  $S^1$ -invariant smooth map

$$S^{2n+1} \times \mathbb{C} \rightarrow \mathbb{C}\mathbb{P}^n \times \mathbb{C}^{n+1},$$

given by

$$S^{2n+1} \times \mathbb{C} \ni (z_0, \dots, z_n, z) \mapsto ([z_0, \dots, z_n], (zz_0, \dots, zz_n))$$

which produces the desired isomorphism between  $S^{2n+1} \times_{\rho_1} \mathbb{C}$  and the tautological line bundle  $\mathbb{U}_n$ .

More generally, for every integer  $m$  we denote by  $\mathcal{O}(m) \rightarrow \mathbb{C}\mathbb{P}^n$  the line bundle associated with the Hopf bundle and the representation

$$\rho_{-m} : S^1 \rightarrow S^1, \quad e^{it} \mapsto e^{-mit}.$$

Thus  $\mathcal{O}(-1) \cong \mathbb{U}_n$ .

Observe that the sections of  $\mathcal{O}(m)$  are given by smooth maps

$$\sigma : S^{2n+1} \rightarrow \mathbb{C}$$

satisfying

$$\sigma(e^{it}v) = e^{mit}\sigma(v).$$

Thus, if  $m \geq 0$ , and  $P \in \mathbb{C}[z_0, \dots, z_n]$  is a homogeneous polynomial of degree  $m$ , then the smooth map

$$S^{2n+1} \ni (z_0, \dots, z_n) \mapsto P(z_0, \dots, z_n)$$

defines a section of  $\mathcal{O}(m)$ . □

We denote by  $\mathbb{U}_\infty \rightarrow BS^1$  the complex line bundle associated with the  $S^1$ -bundle  $S^\infty \rightarrow BS^1$ . The space  $BS^1$  is usually referred to as the *classifying space* of the group  $S^1$ , while  $\mathbb{U}_\infty$  is called the *universal line bundle*. To explain the reason behind this terminology we need to recall a few classical facts.

To any complex line bundle  $L$  over a  $CW$ -complex  $X$  we can associate a cohomology class  $e(L) \in H^2(X)$  called the *Euler class* of  $L$ . It is defined by

$$e(L) := i^* \tau_L,$$

where  $i : X \rightarrow L$  denotes the zero section inclusion,  $D_L$  denotes the unit disk bundle of  $L$ , and  $\tau_L = H^2(D_L, \partial D_L; \mathbb{C})$  denotes the Thom class of  $L$  determined by the canonical orientation defined by the complex structure on  $L$ .

The Euler class is natural in the following sense. Given a continuous map  $f : X \rightarrow Y$  between  $CW$ -complexes and a complex line bundle  $L \rightarrow Y$ , then

$$e(f^*L) = f^*e(L),$$

where  $f^*L \rightarrow X$  denotes the pullback of  $L \rightarrow Y$  via  $f$ .

Often the following result is very useful in determining the Euler class.

**Theorem 3.70 (Gauss–Bonnet–Chern).** *Suppose  $X$  is a compact oriented smooth manifold,  $L \rightarrow X$  is a complex line bundle over  $X$ , and  $\sigma : X \rightarrow L$  is a smooth section of  $L$  vanishing transversally. This means that near a point  $x_0 \in \sigma^{-1}(0)$  the section  $\sigma$  can be represented as a smooth map  $\sigma : X \rightarrow \mathbb{C}$  that is a submersion at  $x_0$ . Then  $S := \sigma^{-1}(0)$  is a smooth submanifold of  $X$ . It has a natural orientation induced from the orientation of  $TX$  and the canonical orientation of  $L$  via the isomorphism*

$$L|_S \cong (TX)|_S / TS.$$

Then  $[S]$  determines a homology class that is Poincaré dual to  $e(L)$ .  $\square$

For a proof we refer to [BT, Proposition 6.24].

**Example 3.71.** The Euler class of the line bundle  $\mathcal{O}(1) \rightarrow \mathbb{C}\mathbb{P}^n$  is the Poincaré dual of the homology class determined by the zero set of the section described in Example 3.69. This zero set is the hyperplane

$$H = \{ [z_0, z_1, \dots, z_n]; z_0 = 0 \}.$$

Its Poincaré dual is the canonical generator of  $H^\bullet(\mathbb{C}\mathbb{P}^n)$ .  $\square$

The importance of  $BS^1$  stems from the following fundamental result [MS, §14].

**Theorem 3.72.** *Suppose  $X$  is a  $CW$ -complex. Then for every complex line bundle  $L \rightarrow X$  there exists a continuous map  $f : X \rightarrow BS^1$  and a line bundle isomorphism  $f^*U_\infty \cong L$ . Moreover,*

$$e(L) = f^*e(U_\infty) = -f^*(\tau) \in H^2(X),$$

where  $\tau$  is the canonical generator<sup>12</sup> of  $H^2(\mathbb{C}\mathbb{P}^\infty)$ .  $\square$

<sup>12</sup> The minus sign in the above formula comes from the fact that the Euler class of the tautological line bundle over  $\mathbb{C}\mathbb{P}^1 \cong S^2$  is the opposite of the generator of  $H^2(\mathbb{C}\mathbb{P}^1)$  determined by the orientation of  $\mathbb{C}\mathbb{P}^1$  as a complex manifold.

The cohomology of the total space of a circle bundle enters into a long exact sequence known as the *Gysin sequence*. For the reader's convenience we include here the statement and the proof of this result.

**Theorem 3.73 (Gysin).** *Suppose  $S^1 \hookrightarrow P \xrightarrow{\pi} B$  is a principal  $S^1$ -bundle over a CW-complex. Denote by  $L \rightarrow B$  the associated complex line bundle and by  $e = e(L) \in H^2(B, \mathbb{C})$  its Euler class. Then we have the following long exact sequence:*

$$\cdots \rightarrow H^\bullet(P) \xrightarrow{\pi_!} H^{\bullet-1}(B) \xrightarrow{e \cup \cdot} H^{\bullet+1}(B) \xrightarrow{\pi^*} H^{\bullet+1}(P) \rightarrow \cdots. \quad (3.30)$$

The morphism  $\pi_! : H^\bullet(P) \rightarrow H^{\bullet-1}(B)$  is called the Gysin map.

*Proof.* Denote by  $D_L$  the unit disk bundle of  $L$  determined by a Hermitian metric on  $L$ . Then  $\partial D_L$  is isomorphic as an  $S^1$ -bundle to  $P$ . Denote by  $i : B \rightarrow L$  the zero section inclusion. We have a Thom isomorphism

$$i_! : H^\bullet(B) \rightarrow H^{\bullet+2}(D_L, \partial D_L),$$

$$H^\bullet(B) \ni \beta \mapsto \tau_L \cup \pi^* \beta \in H^{\bullet+2}(D_L, \partial D_L).$$

Consider now the following diagram, in which the top row is the long exact cohomological sequence of the pair  $(D_L, \partial D_L)$ , all the vertical arrows are isomorphisms, and  $r, q$  are restriction maps (i.e., pullbacks by inclusions)

$$\begin{array}{ccccc} \xrightarrow{q} H^\bullet(\partial D_L) & \xrightarrow{\delta} & H^{\bullet+1}(D_L, \partial D_L) & \xrightarrow{r} & H^{\bullet+1}(D_L) & \xrightarrow{q} \\ \uparrow j & & \uparrow i_! & & \downarrow i^* & \\ H^\bullet(P) & & H^{\bullet-1}(B) & & H^{\bullet+1}(B) & \end{array}$$

The bottom row can thus be completed to a long exact sequence, where the morphism

$$H^{\bullet-1}(B) \rightarrow H^{\bullet+1}(B)$$

is given by

$$i^* r_! (\alpha) = i^* (\tau_L \cup \pi^* \alpha) = i^* (\tau_L) \cup i^* \pi^* (\alpha) = e \cup \alpha, \quad \forall \alpha \in H^{\bullet-1}(B). \quad \square$$

**Definition 3.74.** (a) *We define a left (respectively right)  $S^1$ -space to be a topological space  $X$  together with a continuous left (respectively right)  $S^1$ -action. The set of orbits of a left (resp. right) action is denoted by  $S^1 \backslash X$  (respectively  $X/S^1$ ).*

(b) *An  $S^1$ -map between left  $S^1$ -spaces  $X, Y$  is a continuous  $S^1$ -equivariant map  $X \rightarrow Y$ .*

(c) *If  $X$  is a left  $S^1$ -space we define*

$$X_{S^1} := (S^\infty \times X)/S^1,$$

where the right action of  $S^1$  on  $P_X := (S^\infty \times X)$  is given by

$$(v, x) \cdot e^{it} := (v \cdot e^{it}, e^{-it}x), \quad \forall (v, x) \in S^\infty \times X, \quad t \in \mathbb{R}.$$

(d) We define the  $S^1$ -equivariant cohomology of  $X$  to be

$$H_{S^1}^\bullet(X) := H^\bullet(X_{S^1}). \quad \square$$

*Remark 3.75 (Warning!).* Note that to any left action of a group  $G$  on a set  $S$ ,

$$G \times X \rightarrow S, \quad (g, s) \mapsto g \cdot s,$$

there is an associated right action

$$S \times G \rightarrow S, \quad (s, g) \mapsto s \circ g := g^{-1} \cdot s.$$

We will refer to it as the *right action* dual to the left action. Note that these two actions have the same sets of orbits, i.e.,

$$G \backslash S = S/G.$$

If  $S$  is a topological space and the left action of  $G$  is continuous, then the spaces  $S/G$  and  $G \backslash S$  with the quotient topologies are tautologically homeomorphic.

The differences between right and left actions tend to be blurred even more when the group  $G$  happens to be Abelian, because in this case there is another right action

$$S \times G \rightarrow S, \quad (s, g) \mapsto s * g = g \cdot s.$$

The  $\circ$  and  $*$  actions are sometime confused leading to sign errors in computations of characteristic classes.  $\square$

In the sequel we will work exclusively with *left*  $S^1$ -spaces, and therefore we will refer to them simply as  $S^1$ -spaces.

The natural  $S^1$ -equivariant projection  $S^\infty \times X \rightarrow S^\infty$  induces a continuous map

$$\Psi : X_{S^1} \rightarrow BS^1.$$

We denote by  $\mathcal{L}_X$  the complex line bundle  $\Psi^*U_\infty \rightarrow X_{S^1}$ .

**Proposition 3.76.**  $\mathcal{L}_X$  is isomorphic to the complex line bundle associated with the principal  $S^1$ -bundle

$$S^1 \hookrightarrow P_X \rightarrow X_{S^1}$$

*Proof.* Argue exactly as in Example 3.69.  $\square$

We set  $z := e(\mathcal{L}_X) \in H^2(X_{S^1})$ . The  $\cup$ -product with  $z$  defines a structure of a  $\mathbb{C}[z]$ -module on  $H_{S^1}^\bullet(X)$ . In fact, when we think of the equivariant cohomology of an  $S^1$ -space, we think of it as a  $\mathbb{C}[z]$ -module because it is through this additional structure that we gain information about the action of  $S^1$ .



The module  $H_{S^1}^\bullet(X)$  has a  $\mathbb{Z}/2$ -grading given by the parity of the degree of a cohomology class, and the multiplication by  $z$  preserves this parity. We denote by  $H_{S^1}^\pm(X)$  its even/odd part. Let us point out that  $H_{S^1}^\bullet(X)$  is *not*  $\mathbb{Z}$ -graded as a  $\mathbb{C}[z]$ -module.

Any  $S^1$ -map between  $S^1$ -spaces  $f : X \rightarrow Y$  induces a morphism of  $\mathbb{C}[z]$ -modules

$$f^* : H_{S^1}^\bullet(Y) \rightarrow H_{S^1}^\bullet(X),$$

and given any  $S^1$ -invariant subset  $Y$  of an  $S^1$ -space  $X$  we obtain a long exact sequence of  $\mathbb{C}[z]$ -modules

$$\cdots \rightarrow H_{S^1}^\bullet(X, Y) \rightarrow H_{S^1}^\bullet(X) \rightarrow H_{S^1}^\bullet(Y) \xrightarrow{\delta} H_{S^1}^{\bullet+1}(X, Y) \rightarrow \cdots,$$

where

$$H_{S^1}^\bullet(X, Y) := H^\bullet(X_{S^1}, Y_{S^1}).$$

Moreover, any  $S^1$ -maps that are equivariantly homotopic induce identical maps in equivariant cohomology.

**Example 3.77.** (a) Observe that if  $X$  is a point  $*$ , then

$$H_{S^1}^\bullet(*) \cong H^\bullet(BS^1) = \mathbb{C}[\tau].$$

Any  $S^1$ -space  $X$  is equipped with a *collapse map*  $c_X : X \rightarrow \{*\}$  that induces a morphism

$$c_X^* : \mathbb{C}[\tau] \rightarrow H_{S^1}^\bullet(X).$$

We see that  $c_X^*$  induces the canonical  $\mathbb{C}[z]$ -module structure on  $H_{S^1}^\bullet(X)$ , where  $z = c_X^*(-\tau)$ .

(b) Suppose that  $S^1$  acts trivially on  $X$ . Then

$$X_{S^1} = BS^1 \times X, \quad H_{S^1}^\bullet(X) \cong H^\bullet(BS^1) \otimes H^\bullet(X) \cong \mathbb{C}[\tau] \otimes H^\bullet(X)$$

and  $z = -\tau$ . Hence  $H_{S^1}^\bullet(X)$  is a free  $\mathbb{C}[z]$ -module.

(c) Suppose  $X$  is a *left*  $S^1$ -space such that  $S^1$  acts freely on  $X$ . The natural map  $(S^\infty \times X) \rightarrow X$  is equivariant (with respect to the right action on  $S^\infty \times X$  and the dual right action on  $X$ ) and induces a map

$$X_{S^1} = (S^\infty \times X)/S^1 \rightarrow X/S^1.$$

If  $X$  and  $X/S^1$  are reasonable spaces (e.g., are locally contractible), then the map  $\pi : X_{S^1} \rightarrow X/S^1$  is a fibration with fiber  $S^\infty$ . The long exact homotopy sequence of this fibration shows that  $\pi$  is a weak homotopy equivalence and thus induces an isomorphism in homology (see [Ha, Proposition 4.21]). In particular,  $H_{S^1}^\bullet(X) \cong H^\bullet(X/S^1)$ .

If  $e(X/S^1)$  denotes the Euler class of the  $S^1$ -bundle  $X \rightarrow X/S^1$ , then the multiplication by  $z$  is given by the cup product with  $e(X/S^1)$ . In particular,  $z$  is nilpotent. For example, if

$$X = S^{2n+1} = \left\{ (z_0, z_1, \dots, z_n) \in \mathbb{C}^{n+1}; \sum_k |z_k|^2 = 1 \right\},$$

and the action of  $S^1$  is given by

$$e^{it} \cdot (z_0, \dots, z_n) = (e^{it} z_0, \dots, e^{it} z_n),$$

then  $X/S^1 = \mathbb{C}\mathbb{P}^n$  and

$$H_{S^1}^\bullet(X) = H^\bullet(\mathbb{C}\mathbb{P}^n) \cong \mathbb{C}[z]/(z^{n+1}), \quad \deg z = 2.$$

(d) For every nonzero integer  $k$  denote by  $[S^1, k]$  the circle  $S^1$  equipped with the action of  $S^1$  given by

$$S^1 \times [S^1, k] \ni (z, u) \mapsto z^k \cdot u.$$

Equivalently, we can regard  $[S^1, k]$  as the quotient  $S^1/\mathbb{Z}/k$  equipped with the natural action of  $S^1$ . We want to prove that

$$H_{S^1}^\bullet([S^1, k]) = H^0(*) = \mathbb{C},$$

where  $*$  denotes a space consisting of a single point. We have a fibration

$$\mathbb{Z}/k \hookrightarrow \underbrace{(S^\infty \times S^1)/S^1}_{:=L_1} \xrightarrow{\pi} \underbrace{(S^\infty \times [S^1, k])/S^1}_{:=L_k}.$$

In other words,  $L_1$  is a cyclic covering space of  $L_k$ .

Note that  $L_1 \cong S^\infty$  is contractible and

$$H^\bullet(L_k) = H_{S^1}^\bullet([S^1, k]).$$

We claim that

$$H_m(L_k, \mathbb{C}) = 0, \quad \forall m > 0, \tag{3.31}$$

so that  $H_{S^1}^\bullet([S^1, k]) = H^0(*) = \mathbb{C}$ .

To prove the claim, observe first that the action of  $\mathbb{Z}/k$  induces a free action on the set of singular simplices in  $L_1$  and thus a linear action on the vector space  $C_\bullet(L_1, \mathbb{C})$  of singular chains in  $L_1$  with complex coefficients. We denote this action by

$$\mathbb{Z}/k \times c \ni (\rho, c) \mapsto \rho \circ c.$$

We denote by  $\bar{C}_\bullet(L_1, \mathbb{C})$  the subcomplex of  $C_\bullet(L_1, \mathbb{C})$  consisting of  $\mathbb{Z}/k$ -invariant chains.

We obtain by averaging a natural projection,

$$\mathbf{a} := C_\bullet(L_1, \mathbb{C}) \rightarrow \bar{C}_\bullet(L_1, \mathbb{C}), \quad c \mapsto \mathbf{a}(c) := \frac{1}{k} \sum_{\rho \in \mathbb{Z}/k} \rho \circ c.$$

This defines a *morphism of chain complexes*

$$\mathbf{a} : C_\bullet(L_1, \mathbb{C}) \rightarrow C_\bullet(L_1, \mathbb{C}),$$

with image  $\bar{C}_\bullet(L_1, \mathbb{C})$ .

Each singular  $m$ -simplex  $\sigma$  in  $L_k$  admits precisely  $k$ -lifts to  $L_1$ ,

$$\tilde{\sigma}^1, \dots, \tilde{\sigma}^k : \Delta_m \rightarrow L_1.$$

These lifts form an orbit of the  $\mathbb{Z}/k$  action on the set of singular simplices in  $L_1$ . We define a map

$$C_m(L_k, \mathbb{C}) \rightarrow C_m(L_1, \mathbb{C}), \quad c = \sum_{\alpha} z_{\alpha} \sigma_{\alpha} \mapsto \hat{c} = \sum_{\alpha} z_{\alpha} \hat{\sigma}_{\alpha},$$

where

$$\hat{\sigma} := \frac{1}{k} \sum_{i=1}^k \tilde{\sigma}^i, \quad \forall \sigma : \Delta_m \rightarrow L_k.$$

Clearly  $\hat{c}$  is  $\mathbb{Z}/k$ -invariant and

$$\widehat{\partial c} = \partial \hat{c}.$$

We have thus produced a *morphism of chain complexes*

$$\pi^! : C_\bullet(L_k, \mathbb{C}) \rightarrow \bar{C}_\bullet(L_1, \mathbb{C}), \quad c \mapsto \hat{c}.$$

Denote by  $\pi_*$  the morphism of chain complexes  $C_\bullet(L_1, \mathbb{C}) \rightarrow C_\bullet(L_k, \mathbb{C})$  induced by the projection  $\pi : L_1 \rightarrow L_k$ . Observe that

$$\pi^! \circ \pi_* = \mathbf{a}.$$

This shows that the restriction of the morphism  $\pi_*$  to the subcomplex  $\bar{C}_\bullet(L_1, \mathbb{C})$  of invariant chains is injective.

Suppose now that  $c$  is a singular chain in  $C_m(L_k, \mathbb{Z})$  such that  $\partial c = 0$ . Then

$$\pi_* \hat{c} = c, \quad \pi_*(\partial \hat{c}) = \partial \pi_* \hat{c} = \partial c = 0.$$

Since  $\partial \hat{c}$  is an invariant chain and  $\pi_*$  is injective on the space of invariant chains we deduce  $\partial \hat{c} = 0$ .

On the other hand,  $L_1$  is contractible, so there exists  $\hat{u} \in C_{m-1}(L_1, \mathbb{C})$  such that  $\partial \hat{u} = \hat{c}$ . Thus

$$c = \pi_* \hat{c} = \pi_* \partial \hat{u} = \partial \pi_* \hat{u}.$$

This shows that every  $m$ -cycle in  $L_k$  is a boundary.

(e) Suppose  $X = \mathbb{C}$  and  $S^1$  acts on  $X$  via

$$S^1 \times \mathbb{C} \ni (e^{it}, z) \mapsto e^{-mit} z.$$

Then  $X_{S^1}$  is the total space of the complex line bundle  $\mathcal{O}(m) \rightarrow \mathbb{C}\mathbb{P}^\infty$ .  $\square$

*Remark 3.78.* The spaces  $L_k$  in Example 3.77(c) are the Eilenberg–Mac Lane spaces  $K(\mathbb{Z}/k, 1)$  while  $BS^1$  is the Eilenberg–Mac Lane space  $K(\mathbb{Z}, 2)$ . We have (see [Ha, Example 2.43])

$$H_m(L_k, \mathbb{Z}) = \begin{cases} \mathbb{Z} & \text{if } m = 0, \\ 0 & \text{if } m \text{ is even and positive,} \\ \mathbb{Z}/k & \text{if } m \text{ is odd.} \end{cases} \quad \square$$

We will say that a topological space  $X$  has *finite type* if its singular homology with complex coefficients is a finite dimensional vector space, i.e.,

$$\sum_k b_k(X) < \infty.$$

An  $S^1$ -space is said to be of *finite type* if its equivariant cohomology is a finitely generated  $\mathbb{C}[z]$ -module.

**Proposition 3.79.** *If  $X$  is a reasonable space (e.g., a Euclidean neighborhood retract, ENR<sup>13</sup>) and  $X$  has finite type, then for any  $S^1$ -action on  $X$  the resulting  $S^1$ -space has finite type.*

*Proof.*  $X_{S^1}$  is the total space of a locally trivial fibration

$$X \hookrightarrow X_{S^1} \rightarrow BS^1$$

and the cohomology of  $X_{S^1}$  is determined by the Leray–Serre spectral sequence of this fibration whose  $E_2$ -term is

$$E_2^{p,q} = H^p(BS^1) \otimes H^q(X).$$

The complex  $E_2$  has a natural structure of a *finitely generated*  $\mathbb{C}[z]$ -module. The class  $z$  lives in  $E_2^{2,0}$ , so that  $d_2 z = 0$ . Since the differential  $d_2$  is an odd derivation with respect to the  $\cup$ -product structure on  $E_2$  (see [BT, Theorem 15.11]), we deduce that  $d_2$  commutes with multiplication by  $z$ , so that  $d_2$  is a morphism of  $\mathbb{C}[z]$ -modules. Hence the later terms  $E_r$  of the spectral sequence will be *finitely generated*  $\mathbb{C}[z]$ -modules since they are quotients of submodules of finitely generated  $\mathbb{C}[z]$ -modules. If we let  $r > 0$  denote the largest integer such that  $b_r(X) \neq 0$ , we deduce that

$$E_{r+1} = E_{r+2} = \cdots = E_\infty.$$

Hence  $E_\infty$  is a finitely generated  $\mathbb{C}[z]$ -module. This proves that  $H_{S^1}^\bullet(X)$  is an iterated extension of a finitely generated  $\mathbb{C}[z]$ -module by modules of the same type.  $\square$

<sup>13</sup> For example, any compact  $CW$ -complex is an  $ENR$  or the zero set of an analytic map  $F : \mathbb{R}^n \rightarrow \mathbb{R}^m$  is an  $ENR$ . For more details we refer to the appendix of [Ha].

The finitely generated  $\mathbb{C}[z]$ -modules have a simple structure. Any such module  $M$  fits in a short (split) exact sequence of  $\mathbb{C}[z]$ -modules

$$0 \rightarrow M_{\text{tors}} \rightarrow M \rightarrow M_{\text{free}} \rightarrow 0.$$

If  $M$  is  $\mathbb{Z}/2$ -graded, and  $z$  is even, then there are induced  $\mathbb{Z}/2$ -gradings in  $M_{\text{free}}$  and  $M_{\text{tors}}$ , so that the even/odd parts of the above sequence are also exact sequences.

The free part  $M_{\text{free}}$  has the form  $\bigoplus_{i=1}^r \mathbb{C}[z]$ , where the positive integer  $r$  is called the *rank* of  $M$  and is denoted by  $\text{rank}_{\mathbb{C}[z]} M$ . The classification of finitely generated torsion  $\mathbb{C}[z]$ -modules is equivalent to the classification of endomorphisms of finite dimensional complex vector spaces according to their normal Jordan form.

If  $T$  is a finitely generated torsion  $\mathbb{C}[z]$ -module then as a  $\mathbb{C}$ -vector space  $T$  is finite dimensional. The multiplication by  $z$  defines a  $\mathbb{C}$ -linear map

$$A_z : T \rightarrow T, \quad T \ni t \mapsto z \cdot t.$$

Denote by  $P_z(\lambda)$  the characteristic polynomial of  $A_z$ ,  $P_z(\lambda) = \det(\lambda \mathbb{1}_T - A_z)$ . The *support* of  $T$  is defined by

$$\text{supp } T := \{a \in \mathbb{C}; P_z(a) = 0\}.$$

For a free  $\mathbb{C}[z]$ -module  $M$  we define  $\text{supp } M := \mathbb{C}$ . For an arbitrary  $\mathbb{C}[z]$ -module  $M$  we now set

$$\text{supp } M = \text{supp } M_{\text{tors}} \cup \text{supp } M_{\text{free}}.$$

Thus a finitely generated  $\mathbb{C}[z]$ -module  $M$  is torsion if and only if its support is finite. Note that for such a module we have the equivalence

$$\text{supp } M = \{0\} \iff \exists n \in \mathbb{Z}_{>0} : z^n \cdot m = 0, \quad \forall m \in M.$$

We say that a  $\mathbb{C}[z]$ -module  $M$  is *negligible* if it is finitely generated and  $\text{supp } M = \{0\}$ . Similarly, an  $S^1$ -space  $X$  is called *negligible* if it has finite type and  $H_{S^1}^\bullet(X)$  is a negligible  $\mathbb{C}[z]$ -module

$$\text{supp } M = \{0\}.$$

The negligible modules are pure torsion modules. Example 3.77 shows that if the action of  $S^1$  on  $X$  is free and of finite type then  $X$  is negligible, while if  $S^1$  acts trivially on  $X$  then  $H_{S^1}^\bullet(X)_{\text{tors}} = 0$ .

For an  $S^1$ -action on a compact smooth manifold  $M$  the *equivariant localization theorem* of A. Borel [Bo] and Atiyah–Bott [AB2] essentially says that the free part of  $H_{S^1}^\bullet(M)$  is due entirely to the fixed point set of the action.

**Theorem 3.80.** *Suppose  $S^1$  acts smoothly and effectively on the compact smooth manifold  $M$ . Denote by  $F = \text{Fix}_{S^1}(M)$  the fixed point set of this action,*

$$F = \{x \in M; e^{it} \cdot x = x, \forall t \in \mathbb{R}\}.$$

Then the kernel and cokernel of the morphism  $i^* : H_{S^1}^\bullet(M) \rightarrow H_{S^1}^\bullet(F)$  are negligible  $\mathbb{C}[z]$ -modules. In particular,

$$\text{rank}_{\mathbb{C}[z]} H_{S^1}^\pm(M) = \dim_{\mathbb{C}} H^\pm(F), \quad (3.32)$$

where for any topological space  $X$  we set

$$H^\pm(X) := \bigoplus_{k=\text{even/odd}} H^k(X).$$

*Proof.* We follow [AB2], which is in essence a geometrical translation of the spectral sequence argument employed in [Bo, Hs]. We equip  $M$  with an  $S^1$ -invariant metric, so that  $S^1$  acts by isometries. Arguing as in the proof of Lemma 3.54, we deduce that  $F$  is a (possibly disconnected) smooth submanifold of  $M$ . To proceed further we need to use the following elementary facts.

**Lemma 3.81.** (a) If  $A \xrightarrow{f} B \xrightarrow{g} C$  is an exact sequence of finitely generated  $\mathbb{C}[z]$ -modules, then

$$\text{supp } B \subset \text{supp } A \cup \text{supp } C. \quad (3.33)$$

In particular, if the sequence  $0 \rightarrow A \rightarrow B \rightarrow C \rightarrow 0$  is exact and two of the three modules in it are negligible, then so is the third.

(b) Suppose  $f : X \rightarrow Y$  is an equivariant map between  $S^1$ -spaces of finite type such that  $Y$  is negligible. Then  $X$  is negligible as well. In particular, if  $X$  is a finite type  $S^1$ -space that admits an  $S^1$ -map  $f : X \rightarrow [S^1, k]$ ,  $k > 0$ , then  $X$  is negligible.

(c) Any finite type invariant subspace of a negligible  $S^1$ -space is negligible.

(d) If  $U$  and  $V$  are negligible invariant open subsets of an  $S^1$  space, then their union is also negligible.

*Proof.* Part (a) is a special case of a classical fact of commutative algebra, [S, I.5]. For the reader's convenience we present the simple proof of this special case.

Clearly the inclusion (3.33) is trivially satisfied when either  $A_{\text{free}}$  or  $C_{\text{free}}$  is nontrivial. Thus assume  $A = A_{\text{tors}}$  and  $C = C_{\text{tors}}$ . Observe that we have a short exact sequence

$$0 \rightarrow \ker f \rightarrow B \rightarrow \text{Im } g \rightarrow 0. \quad (3.34)$$

Note that  $\text{supp } \ker f \subset \text{supp } A$  and  $\text{supp } \text{Im } g \subset \text{supp } C$ . We then have an isomorphism of vector spaces

$$B \cong \ker f \oplus \text{Im } g.$$

Denote by  $\alpha_z$  the linear map induced by multiplication by  $z$  on  $\ker f$ , by  $\beta_z$  the linear map induced on  $B$ , and by  $\gamma_z$  the linear map induced on  $\text{Im } g$ . Using

the exactness (3.34) we deduce that  $\beta_z$ , regarded as a  $\mathbb{C}$ -linear endomorphism of  $\ker f \oplus \operatorname{Im} g$ , has the upper triangular block decomposition

$$\beta_z = \begin{bmatrix} \alpha_z & * \\ 0 & \gamma_z \end{bmatrix},$$

where  $*$  denotes a linear map  $\operatorname{Im} g \rightarrow \ker f$ . Then

$$\det(\lambda \mathbb{1} - \beta_z) = \det(\lambda \mathbb{1} - \alpha_z) \det(\lambda \mathbb{1} - \gamma_z),$$

which shows that

$$\operatorname{supp} B = \operatorname{supp} \ker f \cup \operatorname{supp} \operatorname{Im} g \subset \operatorname{supp} A \cup \operatorname{supp} C.$$

(b) Consider an  $S^1$ -map  $f : X \rightarrow Y$ . Note that  $c_X = c_Y \circ f$ , and we have a sequence

$$\mathbb{C}[\tau] = H_{S^1}^\bullet(*) \xrightarrow{c_Y^*} H_{S^1}^\bullet(Y) \xrightarrow{f^*} H_{S^1}^\bullet(X).$$

On the other hand, since  $\operatorname{supp} H_{S^1}^\bullet(Y) = \{0\}$ , we deduce that  $c_Y^*(\tau)^n = 0$  for some positive integer  $n$ . We deduce that  $c_X^*(\tau) = 0$ , so that  $\operatorname{supp} H_{S^1}^\bullet(X) = \{0\}$ . If  $Y = [S^1, k]$ , then we know from Example 3.77(c) that  $\operatorname{supp} H_{S^1}^\bullet(Y) = \{0\}$ .

(c) If  $U$  is an invariant subset of the negligible  $S^1$ -space  $X$ , then applying (b) to the inclusion  $U \hookrightarrow X$  we deduce that  $U$  is negligible.

(d) Finally, if  $U, V$  are negligible invariant open subsets of the  $S^1$ -space  $X$ , then the Mayer–Vietoris sequence yields the exact sequence

$$H_{S^1}^{\bullet-1}(U \cap V) \rightarrow H_{S^1}^\bullet(U \cup V) \rightarrow H_{S^1}^\bullet(U) \oplus H_{S^1}^\bullet(V).$$

Part (c) shows that  $U \cap V$  is negligible. The claim now follows from (a).  $\square$

Our next result will use Lemma 3.81 to produce a large supply of negligible invariant subsets of  $M$ .

**Lemma 3.82.** *Suppose that the stabilizer of  $x \in M$  is the finite cyclic group  $\mathbb{Z}/k$ . Then for any open neighborhood  $U$  of the orbit  $\mathcal{O}_x$  of  $x$  there exists an open  $S^1$ -invariant neighborhood  $U_x$  of  $\mathcal{O}_x$  contained in  $U$  that is of finite type and is equipped with an  $S^1$ -map  $f : U_x \rightarrow [S^1, k]$ . In particular,  $U_x$  is negligible.*

*Proof.* Fix an  $S^1$ -invariant metric  $g$  on  $M$ . The orbit  $\mathcal{O}_x$  of  $x$  is equivariantly diffeomorphic to  $[S^1, k]$ . For  $r > 0$  we set

$$U_x(r) = \{y \in M; \operatorname{dist}(y, \mathcal{O}_x) < r\}.$$

Since  $S^1$  acts by isometries,  $U_x(r)$  is an open  $S^1$ -invariant set.

For every  $y \in \mathcal{O}_x$  we denote by  $T_y \mathcal{O}_x^\perp$  the orthogonal complement of  $T_y \mathcal{O}_x$  in  $T_y M$ . We thus obtain a vector bundle  $T \mathcal{O}_x^\perp \rightarrow \mathcal{O}_x$ . Denote by  $D_r^\perp$  the

associated bundle of open disks of radius  $r$ . If  $r > 0$  is sufficiently small then the exponential map determined by the metric  $g$  defines a diffeomorphism

$$\exp : D_r^\perp \rightarrow U_x(r).$$

In this case, arguing exactly as in the proof of the classical Gauss lemma in Riemannian geometry (see [Ni1, Lemma 4.1.22]), we deduce that for every  $y \in U_x(r)$  there exists a unique  $\pi(y) \in \mathcal{O}_x$  such that

$$\text{dist}(y, \pi(y)) = \text{dist}(y, \mathcal{O}_x).$$

The resulting map  $\pi : U_x(r) \rightarrow \mathcal{O}_x = [S^1, k]$  is continuous and equivariant. Clearly,  $U_x(r)$  is of finite type for  $r > 0$  sufficiently small, and for every neighborhood  $U$  of  $\mathcal{O}_x$  we can find  $r > 0$  such that  $U_x(r) \subset U$ .  $\square$

*Remark 3.83.* Observe that the assumption that the stabilizer of a point  $x$  is finite is equivalent to the fact that  $x$  is not a fixed point of the  $S^1$ -action.  $\square$

For every  $\varepsilon > 0$  sufficiently small we define the  $S^1$ -invariant subset of  $M$

$$\bar{M}_\varepsilon := \{y \in M; \text{dist}(y, F) \geq \varepsilon\}, \quad U_\varepsilon = M \setminus \bar{M}_\varepsilon.$$

Observe that  $\bar{M}_\varepsilon$  is the complement of an open thin tube  $U_\varepsilon$  around the fixed point set  $F$ .

**Lemma 3.84.** *For all  $\varepsilon > 0$  sufficiently small, the set  $\bar{M}_\varepsilon$  is negligible.*

*Proof.* Cover  $\bar{M}_\varepsilon$  by finitely many negligible open sets of the type  $U_x$  described in Lemma 3.82. Denote them by  $U_1, \dots, U_\nu$ . Proposition 3.79 implies that  $V_i = U_i \cap \bar{M}_\varepsilon$  is of finite type and we deduce from Lemma 3.81 and Lemma 3.82 that

$$\text{supp } H_{S^1}^\bullet(V_i) = \text{supp } H_{S^1}^\bullet(U_1) = \{0\}.$$

Now define recursively

$$W_1 = U_1, \quad W_{i+1} = W_i \cup V_{i+1}, \quad 1 \leq i < \nu.$$

Using Lemma 3.81(d) we deduce inductively that  $\bar{M}_\varepsilon$  is negligible.  $\square$

Observe that the natural morphism  $H_{S^1}^\bullet(U_\varepsilon) \rightarrow H_{S^1}^\bullet(F)$  is an isomorphism for all  $\varepsilon > 0$  sufficiently small, so we need to understand the kernel and cokernel of the map

$$H_{S^1}^\bullet(M) \rightarrow H_{S^1}^\bullet(U_\varepsilon).$$

The long exact sequence of the pair  $(M, U_\varepsilon)$  shows that these are submodules of  $H_{S^1}^\bullet(M, U_\varepsilon)$ . Thus, it suffices to show that  $H_{S^1}^\bullet(M, U_\varepsilon)$  is a negligible  $\mathbb{C}[z]$ -module. By excision we have

$$H_{S^1}^\bullet(M, U_\varepsilon) = H_{S^1}^\bullet(\bar{M}_\varepsilon, \partial\bar{M}_\varepsilon).$$



Lemma 3.81(c) implies that  $\partial\bar{M}_\varepsilon$  is negligible.

Using the long exact sequence of the pair  $(\bar{M}_\varepsilon, \partial\bar{M}_\varepsilon)$  we obtain an exact sequence

$$H_{S^1}^\mp(\partial\bar{M}_\varepsilon) \longrightarrow H_{S^1}^\pm(\bar{M}_\varepsilon, \partial\bar{M}_\varepsilon) \longrightarrow H_{S^1}^\pm(\bar{M}_\varepsilon).$$

Since the two extremes of this sequence are negligible, we deduce from Lemma 3.81(a) that the middle module is negligible as well. This proves that both the kernel and the cokernel of the morphism  $H_{S^1}^\bullet(M) \rightarrow H_{S^1}^\bullet(F)$  are negligible  $\mathbb{C}[z]$ -modules.

On the other hand, according to Example 3.77(d), the  $\mathbb{C}[z]$ -module  $H_{S^1}^\bullet(F)$  is free and thus

$$\ker\left(H_{S^1}^\bullet(M) \rightarrow H_{S^1}^\bullet(F)\right) = H_{S^1}^\bullet(M)_{\text{tors}}.$$

We thus have an injective map  $H_{S^1}^\bullet(M)_{\text{free}} \rightarrow H_{S^1}^\bullet(F)$  whose cokernel is a torsion module. We deduce that

$$\text{rank}_{\mathbb{C}[z]} H_{S^1}^\pm(M) = \text{rank}_{\mathbb{C}[z]} H_{S^1}^\pm(F) = \dim_{\mathbb{C}} H^\pm(F). \quad \square$$

From the localization theorem we deduce the following result of P. Conner [Co]. For a different approach we refer to [Bo, IV.5.4].

**Corollary 3.85.** *Suppose the torus  $\mathbb{T}$  acts on the compact smooth manifold  $M$ . Let  $M$  and  $F$  be as in Theorem 3.80. Then*

$$\dim_{\mathbb{C}} H^\pm(M) \geq \dim_{\mathbb{C}} H^\pm(\text{Fix}_{\mathbb{T}}(M)). \quad (3.35)$$

*Proof.* We will argue by induction on  $\dim \mathbb{T}$ . To start the induction, assume first that  $\mathbb{T} = S^1$ . Consider the  $S^1$ -bundle  $P_M = S^\infty \times M \rightarrow M_{S^1}$ . Since  $S^\infty$  is contractible the Gysin sequence of this  $S^1$ -bundle can be rewritten as

$$\cdots \rightarrow H^\bullet(M) \rightarrow H_{S^1}^{\bullet-1}(M) \xrightarrow{z\cup} H_{S^1}^{\bullet+1}(M) \rightarrow H^{\bullet+1}(M) \rightarrow \cdots.$$

In particular we deduce that we have an injection

$$H_{S^1}^\pm(M)/zH_{S^1}^\pm(M) \hookrightarrow H^\pm(M).$$

Using a (noncanonical) direct sum decomposition

$$H_{S^1}^\pm(M) = H_{S^1}^\pm(M)_{\text{tors}} \oplus H_{S^1}^\pm(M)_{\text{free}}$$

we obtain an injection

$$H_{S^1}^\pm(M)_{\text{free}}/zH_{S^1}^\pm(M)_{\text{free}} \hookrightarrow H^\pm(M).$$

The above quotient is a finite dimensional complex vector space of dimension equal to the rank of  $H_{S^1}^\pm(M)$ , and from the localization theorem we deduce

$$\begin{aligned} \dim_{\mathbb{C}} H^{\pm}(F) &= \dim_{\mathbb{C}} H_{S^1}^{\pm}(M)_{\text{free}}/zH_{S^1}^{\pm}(M)_{\text{free}} \\ &\leq \dim_{\mathbb{C}} H^{\pm}(M) = \dim_{\mathbb{C}} H^{\pm}(M). \end{aligned}$$

□

Suppose now that  $\mathbb{T}$  is an  $n$ -dimensional torus such that  $\mathbb{T}' = \mathbb{T} \times S^1$  acts on  $M$ . Let  $F'$  denote the fixed point set of  $\mathbb{T}'$  and let  $F$  denote the fixed point set of  $\mathbb{T}$ . They are both submanifolds of  $M$  and  $F' \subset F$ . The component  $S^1$  acts on  $F$ , and we have

$$F' = \text{Fix}_{S^1}(F).$$

The induction hypothesis implies

$$\dim_{\mathbb{C}} H^{\pm}(M) \geq \dim_{\mathbb{C}} H^{\pm}(F),$$

while the initial step of the induction shows that

$$\dim_{\mathbb{C}} H^{\pm}(F) \geq \dim_{\mathbb{C}} H^{\pm}(\text{Fix}_{S^1}(F)) = \dim_{\mathbb{C}} H^{\pm}(F'). \quad \square$$

**Theorem 3.86.** *Suppose  $(M, \omega)$  is a compact symplectic manifold equipped with a Hamiltonian action of a torus  $\mathbb{T}$  with moment map  $\mu : M \rightarrow \mathfrak{t}^*$ . Then for every  $X \in \mathfrak{t}$  the function  $\xi_X : M \rightarrow \mathbb{R}$  given by  $\xi_X(x) = \langle \mu(x), X \rangle$ ,  $x \in M$ , is a perfect Morse–Bott function.*

*Proof.* We use the strategy in [Fra]. We already know from Theorem 3.52 that  $\xi_X$  is a Morse–Bott function. Moreover, its critical set is the fixed point set  $F$  of the closed torus  $\mathbb{T}_X \subset \mathbb{T}$  generated by  $e^{tX}$ . Denote by  $\{F_{\alpha}\}$  the connected components of this fixed point set and by  $\lambda_{\alpha}$  the Morse index of the critical submanifold  $F_{\alpha}$ . We then have the Morse–Bott inequalities

$$\sum_{\alpha} t^{\lambda_{\alpha}} P_{C_{\alpha}}(t) \succcurlyeq P_M(t). \quad (3.36)$$

If we set  $t = 1$  we deduce

$$\sum_k b_k(F) = \sum_{\alpha} \sum_k b_k(F_{\alpha}) \geq \sum_k b_k(M). \quad (3.37)$$

The inequality (3.35) shows that we actually have equality in (3.37), and this in turn implies that we have equality in (3.36), i.e.,  $f$  is a perfect Morse–Bott function. □

*Remark 3.87.* (a) The perfect Morse–Bott functions on complex Grassmannians used in the proof of Proposition 3.11 are of the type discussed in the above theorem. For a very nice discussion of Morse theory, Grassmannians and equivariant cohomology we refer to the survey paper [Gu]. For more refined applications of equivariant cohomology to Morse theory we refer to [AB1, B2].

(b) In the proof of Theorem 3.86 we have shown that for every Hamiltonian action of a torus  $\mathbb{T}$  on a compact symplectic manifold we have

$$\sum_k \dim H^k(\text{Fix}_{\mathbb{T}}(M)) = \sum_k H^k(M).$$

Such actions of  $\mathbb{T}$  are called *equivariantly formal* and enjoy many interesting properties. We refer to [Bo, XII] and [GKM] for more information on these types of actions.  $\square$

### 3.7 The Duistermaat-Heckman formula

We have now at our disposal all the information we need to prove the celebrated Duistermaat-Heckman localization formula, [DH]. This is a multifaceted result but, due to space constraints, we limit ourselves to discussing only one of its facets, analytical in nature. To understand its significance we need to present a classical result.

**Proposition 3.88 (Stationary Phase Principle).** *Suppose that  $(M, g)$  is a smooth, connected oriented Riemannian manifold of dimension  $m$ ,*

$$a, \varphi : M \rightarrow \mathbb{R}$$

*are smooth functions such that  $a$  has compact support, and all the critical points of  $\varphi$  contained in  $\text{supp } a$  are nondegenerate. For any point  $p \in \text{Cr}_{\varphi} \cap \text{supp } a$  we denote by  $\sigma(p, \varphi)$  the signature of the Hessian  $H_{\varphi,p}$  of  $\varphi$  at  $p$ . Using the metric  $g$  we can identify the Hessian with a symmetric linear operator  $T_p M \rightarrow T_p M$  and we denote by  $\det_g H_{\varphi,p}$  its determinant. Then as  $t \rightarrow \infty$  we have*

$$\int_M e^{it\varphi} a dV_g = \sum_{p \in \text{Cr}_{\varphi} \cap \text{supp } a} \left(\frac{2\pi}{t}\right)^{\frac{m}{2}} \frac{e^{\frac{i\pi\sigma(p,\varphi)}{4}}}{|\det_g H_{\varphi,p}|^{\frac{1}{2}}} e^{it\varphi(p)} a(p) + O(t^{-\frac{m}{2}-1}). \tag{3.38}$$

*Proof.* We will complete the proof in several steps.

**Step 1. (Riemann-Lebesgue Lemma)** Assume that  $(M, g)$  is the Euclidean space  $\mathbb{R}^m$  and  $\text{Cr}_{\varphi} \cap \text{supp } a = \emptyset$ . Then for any  $N > 0$  we have

$$I_t(\varphi, a) = \int_{\mathbb{R}^m} e^{it\varphi(x)} a(x) dx = O(t^{-N}) \text{ as } N \rightarrow \infty$$

Fix compact neighborhoods  $\mathcal{O}_0 \subset \mathcal{O}_1$  of  $\text{supp } a$  such that  $d\varphi \neq 0$  on  $\mathcal{O}_1$  and then define

$$Y := \frac{1}{|\nabla\varphi|} \nabla\varphi \in \text{Vect}(\mathcal{O}_1).$$

Next, choose a smooth function  $\eta : \mathbb{R}^m \rightarrow \mathbb{R}$  which is identically 1 on  $\mathcal{O}_0$  and identically zero outside  $\mathcal{O}_1$ . The vector field  $\eta Y$  extends to a smooth vector field  $X$  on  $\mathbb{R}^m$  that satisfies

$$X \cdot \varphi = d\varphi(X) = 1 \text{ on } \mathcal{O}_0.$$

Note that

$$X \cdot e^{it\varphi} = ite^{i\varphi}.$$

Using the divergence theorem [Ni1, Lemma 10.3.1] and the fact that  $a$  has support contained in  $\mathcal{O}_0$  we deduce that

$$I_t(\varphi, a) = \frac{1}{it} \int_{\mathbb{R}^m} (X \cdot e^{it\varphi}) a dx = \frac{1}{it} \int_{\mathbb{R}^m} e^{it\varphi} (-X \cdot a - \mathbf{div}(X)a) dx,$$

where  $\mathbf{div}(X)$  denotes the divergence of  $X$ . If we write

$$La := -X \cdot a - \mathbf{div}(X)a,$$

then we can rewrite the above equality as.

$$I_t(\varphi, a) = \frac{1}{it}(\varphi, La).$$

Iterating this procedure we deduce that for any  $N > 0$  we have

$$I_t(\varphi, a) = \frac{1}{(it)^N}(\varphi, L^N a).$$

**Step 2.** Suppose that  $Q : \mathbb{R}^m \rightarrow \mathbb{R}^m$  is a symmetric invertible operator and  $\varphi$  is quadratic,

$$\varphi(x) = c + (Qx, x), \quad c \in \mathbb{R}.$$

Then

$$I_t(\varphi, a) = \left(\frac{\pi}{t}\right)^{\frac{m}{2}} \frac{e^{\frac{i\pi \operatorname{sign} Q}{4}}}{|\det Q|^{\frac{1}{2}}} e^{itc} a(0) + O(t^{-\frac{m}{2}-1}) \text{ as } t \rightarrow \infty. \quad (3.39)$$

After an orthogonal change of coordinates we can assume that  $Q$  is diagonal, i.e.,

$$\varphi(x) = c + (Qx, x) = c + \sum_{k=1}^m \lambda_k x_k^2, \quad \lambda_k \in \mathbb{R} \setminus 0.$$

For  $r > 0$  we set

$$I_t(\varphi, a, r) := e^{itc} \int_{\mathbb{R}^m} e^{-r|x|^2 + it\varphi(x)} a(x) dx.$$

Observe that

$$I_t(\varphi, a) = \lim_{r \searrow 0} I_t(\varphi, a, r).$$

Denote by  $A(\xi)$  the Fourier transform of the amplitude  $a(x)$

$$A(\xi) = \frac{1}{(2\pi)^{\frac{m}{2}}} \int_{\mathbb{R}^m} e^{-i(x,\xi)} a(x) dx.$$

Arguing as in Step 1 we deduce that

$$A(\xi) = O(|\xi|^{-N}) \text{ as } \xi \rightarrow \infty, \quad \forall N > 0. \tag{3.40}$$

The Fourier inversion formula [RS, IX] implies

$$a(x) = \frac{1}{(2\pi)^{\frac{m}{2}}} \int_{\mathbb{R}^m} e^{i(x,\xi)} A(\xi) d\xi,$$

so that

$$\begin{aligned} I_t(\varphi, a, r) &= \frac{e^{itc}}{(2\pi)^{\frac{m}{2}}} \int_{\mathbb{R}^m} \left( \int_{\mathbb{R}^m} e^{-r|x|^2 + it\varphi(x) + i(x,\xi)} A(\xi) d\xi \right) dx \\ &= \frac{e^{itc}}{(2\pi)^{\frac{m}{2}}} \int_{\mathbb{R}^m} \left( \int_{\mathbb{R}^m} e^{-r|x|^2 + it\varphi(x) + i(x,\xi)} dx \right) A(\xi) d\xi \\ &= \frac{e^{itc}}{(2\pi)^{\frac{m}{2}}} \int_{\mathbb{R}^m} \left( \prod_{k=1}^m \int_{\mathbb{R}} e^{(-r + it\lambda_k)x_k^2 + i\xi_k x_k} dx_k \right) A(\xi) d\xi. \\ &= \frac{e^{itc}}{(2\pi)^{\frac{m}{2}}} \int_{\mathbb{R}^m} \left( \prod_{k=1}^m J(t\lambda_k, \xi_k, r) \right) A(\xi) d\xi, \end{aligned}$$

where

$$J(\mu, \xi, r) = \int_{\mathbb{R}} e^{(-r + i\mu)x^2 + i\xi x} dx.$$

We now invoke the following classical result whose proof is left to the reader as an exercise (Exercise 6.51).

**Lemma 3.89.** *For every complex number  $z = \rho e^{i\theta}$ ,  $|\theta| < \pi$  we set  $z^{\frac{1}{2}} := \rho^{\frac{1}{2}} e^{\frac{i\theta}{2}}$ . Then, for any  $r > 0$  we have*

$$J(\mu, \xi, r) = \frac{\pi^{\frac{1}{2}}}{(r - i\mu)^{\frac{1}{2}}} e^{\frac{\xi^2}{4(i\mu - r)}}.$$

□

We deduce that

$$I_t(\varphi, a, r) = \frac{e^{itc}}{2^{\frac{m}{2}}} \prod_{k=1}^m \frac{1}{(r - it\lambda_k)^{\frac{1}{2}}} \int_{\mathbb{R}^m} \left( \prod_{k=1}^m e^{\frac{\xi_k^2}{4(it\lambda_k - r)}} \right) A(\xi) d\xi.$$

Letting  $r \searrow 0$  we deduce

$$I_t(\varphi, a) = \frac{e^{itc}}{(2t)^{\frac{m}{2}}} \prod_{k=1}^m \frac{1}{(-i\lambda_k)^{\frac{1}{2}}} \int_{\mathbb{R}^m} \left( \prod_{k=1}^m e^{\frac{-i\xi_k^2}{4t\lambda_k}} \right) A(\xi) d\xi. \quad (3.41)$$

Now observe that

$$\prod_{k=1}^m \frac{1}{(-i\lambda_k)^{\frac{1}{2}}} = \frac{e^{\frac{i\pi \operatorname{sign} Q}{4}}}{|\det Q|^{\frac{1}{2}}},$$

and there exists a constant  $C > 0$ , independent of  $t$  such that

$$\left| \prod_{k=1}^m e^{\frac{-i\xi_k^2}{4t\lambda_k}} - 1 \right| \leq C \frac{|\xi|^2}{t}, \quad \forall t > 1, \quad \xi \in \mathbb{R}^m.$$

Hence, using (3.40) we deduce

$$\int_{\mathbb{R}^m} \left( \prod_{k=1}^m e^{\frac{-i\xi_k^2}{4t\lambda_k}} \right) A(\xi) d\xi = \int_{\mathbb{R}^n} A(\xi) d\xi + O(t^{-1}).$$

On the other hand, the Fourier inversion formula implies

$$\int_{\mathbb{R}^n} A(\xi) d\xi = (2\pi)^{\frac{m}{2}} a(0).$$

Using these equalities in (3.41) we obtain (3.39).

**Step 3.** Suppose that  $M = \mathbb{R}^m$ ,  $\varphi(x) = c + (Qx, x)$  as in Step 2, but the metric  $g$  is not necessarily the Euclidean metric. Then

$$\int_{\mathbb{R}^m} e^{it\varphi(x)} a(x) dV_g(x) = \left( \frac{\pi}{t} \right)^{\frac{m}{2}} \frac{e^{\frac{i\pi \operatorname{sign} Q}{4}}}{|\det_g Q|^{\frac{1}{2}}} e^{itc} a(0) + O(t^{-\frac{m}{2}-1}), \quad \text{as } t \rightarrow \infty.$$

With respect to the Euclidean coordinates  $(x_1, \dots, x_m)$  we have

$$g = (g_{ij})_{1 \leq i, j \leq m}, \quad g_{ij} = g(\partial_{x_i}, \partial_{x_j}),$$

and

$$dV_g(x) = \sqrt{\det g} dx, \quad \det g = \det (g_{ij})_{1 \leq i, j \leq m}.$$

Hence From Step 2 we deduce

$$\int_{\mathbb{R}^m} e^{it\varphi(x)} a(x) dV_g(x) = \int_{\mathbb{R}^m} e^{it\varphi(x)} a_g(x) dx, \quad a_g = a \sqrt{\det g}.$$

From Step 2 we deduce

$$\int_{\mathbb{R}^m} e^{it\varphi(x)} a_g(x) dx = \left( \frac{\pi}{t} \right)^{\frac{m}{2}} \frac{e^{\frac{i\pi \operatorname{sign} Q}{4}}}{|\det Q|^{\frac{1}{2}}} e^{itc} a_g(0) + O(t^{-\frac{m}{2}-1}), \quad \text{as } t \rightarrow \infty.$$

We conclude by observing that

$$\det_g Q = \frac{\det Q}{\det g}.$$

**Step 4.** The general case can now be reduced to the situations covered by Steps 1-3 using the Morse lemma (Theorem 1.12) and partition of unity.  $\square$

The Duistermann-Heckmann theorem describe one instance when the stationary phase asymptotic expansion (3.38) is *exact!*

**Theorem 3.90 (Duistermaat-Heckman).** *Suppose that  $(M, \omega)$  is a smooth, compact, connected symplectic manifold of dimension  $2n$  equipped with a Hamiltonian  $S^1$ -action*

$$M \times S^1 \rightarrow M, \quad (p, e^{i\theta}) \mapsto p \cdot e^{i\theta}$$

*with moment map  $\mu : M \rightarrow \mathfrak{u}(1)$ . As usual, we identify  $\mathfrak{u}(1)$  with  $i\mathbb{R}$  and thus we can write  $\mu(x) = i\varphi(x)$ . Assume that  $\varphi$  is a Morse function. Fix a  $S^1$ -invariant almost complex structure on  $M$  tamed by  $\omega$  and denote by  $g$  the associated metric*

$$g(X, Y) = \omega(X, JY), \quad \forall X, Y \in \text{Vect}(M).$$

*Then  $dV_g = \frac{1}{n!}\omega^n$ , and for any  $t \in \mathbb{C}^*$  we have*

$$\int_M e^{it\varphi(x)} dV_g(x) = \sum_{p \in \text{Cr}_\varphi} \left(\frac{2\pi}{t}\right)^n \frac{e^{\frac{i\pi\sigma(p,\varphi)}{4}}}{|\det_g H_{\varphi,p}|^{\frac{1}{2}}} e^{it\varphi(p)}. \tag{3.42}$$

*Proof.* Our proof is a slight variation of the strategy employed in [BGV, §7.2]. Denote by  $X_\varphi$  the Hamiltonian vector field generated by  $\varphi$ ,

$$X_\varphi = -J\nabla^g\varphi.$$

For any  $0 \leq k \leq 2n$  we denote by  $\Omega_z^k(M) \subset \Omega^k(\mathbb{C}^* \times M)$  the space of differential forms of degree  $k$  on  $M$  depending smoothly on the parameter  $z \in \mathbb{C}^*$ . More precisely,  $\Omega_z^k(M)$  consists of (complex) differential  $k$ -forms  $\alpha$  on  $\mathbb{C}^* \times M$  such that, for any vector field  $Z \in \text{Vect}(\mathbb{C}^* \times M)$  that is tangent to the fibers of the natural projection

$$\pi_M : \mathbb{C}^* \times M \rightarrow M,$$

we have  $Z \lrcorner \alpha = 0$ . Equivalently,  $\Omega_z^k(M)$  consists of smooth sections of the pulled back bundle  $\pi_M^* \Lambda^k T^*M \otimes \mathbb{C} \rightarrow \mathbb{C}^* \times M$ . We set

$$\Omega_z^\bullet(M) = \bigoplus_k \Omega_z^k(M),$$

and we define an operator

$$d_z : \Omega_z^\bullet(M) \rightarrow \Omega_z^\bullet(M), \quad d_z \alpha(z) = d_M \alpha(z) - z X_\varphi \lrcorner \alpha(z),$$

where  $d_M$  denotes the exterior derivative on  $M$ .

We have the following elementary facts whose proofs are left to the reader.

**Lemma 3.91.** (a) *If  $\alpha(z) \in \Omega_z^k(M)$  and  $\beta(z) \in \Omega_z^\ell(M)$ , then*

$$d_z(\alpha(z) \wedge \beta(z)) = d_z \alpha(z) \wedge \beta(z) + (-1)^k \alpha(z) \wedge d_z \beta(z).$$

(b)  $d_z^2 = -z L_{X_\varphi}$ , where  $L_{X_\varphi}$  denotes the Lie derivative along  $X_\varphi$ . □

For any  $\alpha(z) \in \Omega_z^\bullet(M)$  we denote by  $[\alpha(z)]_k$  its degree  $k$  component. Note that

$$[d_z \alpha(z)]_{k+1} = d_M [\alpha(z)]_k - z X_\varphi \lrcorner [\alpha(z)]_{k+2}.$$

The integration defines a linear map

$$\int_M : \Omega_z^{2n}(M) \rightarrow C^\infty(\mathbb{C}^*).$$

Consider the form

$$\alpha(z) = \omega + z \varphi \in \Omega_z^\bullet(M).$$

Since  $X_\varphi$  is the Hamiltonian vector field associated to  $\varphi$  we deduce from (3.16) that

$$d_z \alpha(z) = z(d_M \varphi - X_\varphi \lrcorner \omega) = 0.$$

Using Lemma 3.91(a) we deduce

$$d_z \alpha(z)^k = 0, \quad \forall k,$$

so that  $d_z e^{\alpha(z)} = 0$ . Note that

$$e^{\alpha(z)} = e^{z\varphi} e^\omega = e^{z\varphi} \sum_{k \geq 0} \frac{1}{k!} \omega^k, \quad [e^{\alpha(z)}]_{2n} = e^{z\varphi} \frac{\omega^n}{n!}.$$

Denote by  $\theta_\varphi \in \Omega^1(M)$  the 1-form  $g$ -dual to  $X_\varphi$ , i.e.,

$$\theta_\varphi(Y) = g(X_\varphi, Y), \quad \forall Y \in \text{Vect}(M).$$

We regard  $\theta$  in a canonical way as an element in  $\Omega_z^1(M)$ . Note that

$$d_z \theta_\varphi = \underbrace{d\theta_\varphi - z |X_\varphi|_g^2}_{=: \beta(z)}.$$

Since the metric  $g$  is invariant with respect to the flow generated by  $X_\varphi$  we deduce  $L_{X_\varphi} \theta_\varphi = 0$ . Using Lemma 3.91(b) we deduce  $d_z \beta(z) = 0$ . Set



$$M^* := M \setminus \mathbf{Cr}_\varphi,$$

The vector field  $X_\varphi$  does not vanish on  $M^*$  so that  $\beta(z)$  is invertible in  $\Omega_z^\bullet(M^*)$ , i.e., there exists  $\gamma(z) \in \Omega_z^\bullet(M^*)$  such that

$$\gamma(z) \wedge \beta(z) = 1 \in \Omega_z^\bullet(M^*).$$

More precisely, we can take

$$\begin{aligned} \gamma(z) &= \beta(z)^{-1} = -(z|X_\varphi|_g^2)^{-1} \left( 1 - (z|X_\varphi|_g^2)^{-1} d\theta_\varphi \right)^{-1} \\ &= - \sum_{k=0}^n (z^{-1}|X_\varphi|_g^{-2})^{k+1} (d\theta_\varphi)^k. \end{aligned}$$

Observe that on  $M^*$  we have the equality.

$$d_z(\theta_\varphi \wedge e^{\alpha(z)} \wedge \gamma(z)) = (d_z\theta_\varphi) \wedge e^{\alpha(z)} \wedge \gamma(z) = e^{\alpha(z)}.$$

Hence

$$[e^{\alpha(z)}]_{2n} = d_M[\theta_\varphi \wedge \gamma(z) \wedge e^{\alpha(z)}]_{2n-1}.$$

Let  $p \in \mathbf{Cr}_\varphi$  and  $r > 0$  sufficiently small. Denote by  $B_r(p)$  the (open) ball in  $(M, g)$  of radius  $r$  and centered at  $p$ . Since  $p$  is a fixed point of the  $S^1$ -action, we have an induced  $S^1$ -action on  $T_pM$

$$T_pM \times S^1 \rightarrow T_pM, \quad (v, e^{iJ}) \mapsto e^{t\dot{A}_p}v,$$

where, according to (3.24) the endomorphism  $\dot{A}_p$  of  $T_pM$  is skew-symmetric, commutes with  $J$  and

$$H_{\varphi,p}(u, v) = g_p(J\dot{A}_p u, v), \quad \forall u, v \in T_pM.$$

The endomorphism  $B_p = J\dot{A}_p$  of  $T_pM$  is symmetric and commutes with  $J$ . We can find an orthonormal basis  $\mathbf{e}_1, \mathbf{e}_2, \dots, \mathbf{e}_{2n}$  of  $T_pM$  and numbers  $\lambda_1 = \lambda_1(p), \dots, \lambda_n = \lambda_n(p) \in \mathbb{Z}$  such that<sup>14</sup>  $\forall k = 1, \dots, n$  we have

$$\dot{A}_p \mathbf{e}_{2k-1} = \lambda_k \mathbf{e}_{2k}, \quad \dot{A}_p \mathbf{e}_{2k} = -\lambda_k \mathbf{e}_{2k-1},$$

$$J\mathbf{e}_{2k-1} = \mathbf{e}_{2k}, \quad J\mathbf{e}_{2k} = -\mathbf{e}_{2k-1}.$$

Moreover, since  $p$  is a nondegenerate critical point of  $p$  we have  $\lambda_k \neq 0, \forall k$ . We use the orthonormal basis  $\{\mathbf{e}_k\}$  to introduce coordinates  $\mathbf{x} = (x_1, \dots, x_{2n})$  on  $T_pM$ , and via the exponential map, normal coordinates  $\mathbf{x}$  on  $B_\varepsilon(p)$ . We denote by  $O(\ell)$  any smooth function on  $M$  whose derivatives at  $p$  up to order  $\ell$  are zero.

<sup>14</sup> The eigenvalues  $\lambda_k$  belong to  $\mathbb{Z}$  since  $e^{(t+2\pi)\dot{A}_p} = e^{t\dot{A}_p}, \forall t \in \mathbb{R}$ .

The metric  $g$  is  $S^1$ -invariant and thus the  $S^1$  action preserves distances and maps geodesics to geodesics. Thus, on  $B_\varepsilon(p)$  the  $S^1$ -action is given by

$$\mathbf{x} \cdot e^{it} = e^{t\dot{A}_p} \mathbf{x}.$$

In the  $\mathbf{x}$ -coordinates we have  $g_{ij} = \delta_{ij} + O(2)$  so that

$$\begin{aligned} X_\varphi(\mathbf{x}) &= \dot{A}_p \mathbf{x} = \sum_{k=1}^n \lambda_k (-x_{2k} \partial_{x_{2k-1}} + x_{2k-1} \partial_{x_{2k}}). \\ |X_\varphi(\mathbf{x})|^2 &= \sum_{k=1}^n \lambda_k^2 (x_{2k-1}^2 + x_{2k}^2) + O(2). \end{aligned} \quad (3.43)$$

Note that the Hessian of  $\varphi$  at  $p$  is given by the quadratic form

$$H_{\varphi,p}(\mathbf{x}) = g_p(J\dot{A}_p \mathbf{x}, \mathbf{x}) = - \sum_{k=1}^n \lambda_k (x_{2k-1}^2 + x_{2k}^2). \quad (3.44)$$

The equality (3.43) implies that

$$\begin{aligned} \theta_\varphi &= \sum_{k=1}^n \lambda_k (-x_{2k} dx_{2k-1} + x_{2k-1} dx_{2k}) + O(2), \\ d\theta_\varphi &= \sum_{k=1}^n 2\lambda_k dx_{2k-1} \wedge dx_{2k} + O(1) \end{aligned} \quad (3.45)$$

For  $\varepsilon > 0$  sufficiently small we denote by  $E_\varepsilon(p)$  the ellipsoid

$$E_\varepsilon(p) = \left\{ \mathbf{x} \in B_r(p); \sum_{k=1}^n \lambda_k^2 (x_{2k-1}^2 + x_{2k}^2) = \varepsilon^2 \right\}.$$

We set

$$M_\varepsilon := M \setminus \bigcup_{p \in \mathbf{Cr}_\varphi} E_\varepsilon(p).$$

We deduce

$$\begin{aligned} \int_M [e^{\alpha(z)}]_{2n} &= \lim_{\varepsilon \searrow 0} \int_{M_\varepsilon} [e^{\alpha(z)}]_{2n} \\ &= - \sum_{p \in \mathbf{Cr}_\varphi} \lim_{\varepsilon \searrow 0} \int_{\partial E_\varepsilon(p)} [\theta_\varphi \wedge \gamma(z) \wedge e^{\alpha(z)}]_{2n-1}. \end{aligned} \quad (3.46)$$

We have

$$[\theta_\varphi \wedge \gamma(z) \wedge e^{\alpha(z)}]_{2n-1} = e^{z\varphi} [\theta_\varphi \wedge \gamma(z)]_{2n-1} + \sum_{k=1}^{n-1} [\theta_\varphi \wedge \gamma(z)]_{2k-1} \wedge \frac{1}{(n-k)!} \omega^{n-k}$$

$$\begin{aligned}
 &= -e^{z\varphi} (z^{-1}|X_\varphi|^2)^n \theta_\varphi \wedge (d\theta_\varphi)^{n-1} \\
 &\quad - \sum_{k=1}^{n-1} (z^{-1}|X_\varphi|^{-2})^k \theta_\varphi \wedge (d\theta_\varphi)^{k-1} \wedge \frac{1}{(n-k)!} \omega^{n-k}.
 \end{aligned}$$

Using (3.43) and (3.45) we deduce that for any  $k = 1, \dots, n-1$  we have along  $\partial E_\varepsilon(p)$

$$\left| (z^{-1}|X_\varphi|^{-2})^k \theta_\varphi \wedge (d\theta_\varphi)^{k-1} \wedge \frac{1}{(n-k)!} \omega^{n-k} \right|_g = O(\varepsilon^{1-2k}),$$

uniformly with respect to  $z$  on the compacts of  $\mathbb{C}^*$ . Since the area of  $\partial E_\varepsilon(p)$  is  $O(\varepsilon^{2n-1})$  we deduce that

$$\lim_{\varepsilon \searrow 0} \int_{\partial E_\varepsilon(p)} [\theta_\varphi \wedge \gamma(z)]_{2k-1} \wedge \frac{1}{(n-k)!} \omega^{n-k} = 0, \quad \forall k = 1, \dots, n-1.$$

Using (3.46) we deduce

$$\int_M [e^{\alpha(z)}]_{2n} = z^{-n} \sum_{\mathbf{p} \in \mathbf{Cr}_\varphi} \lim_{\varepsilon \searrow 0} \int_{\partial E_\varepsilon(p)} |X_\varphi|^{-2n} e^{z\varphi} \theta_\varphi \wedge (d\theta_\varphi)^{n-1}. \quad (3.47)$$

On  $B_r(p)$  we have

$$e^{z\varphi} = e^{z\varphi(p)} + O(|\mathbf{x}|), \quad |X_\varphi(\mathbf{x})| = \varepsilon(1 + O(|\mathbf{x}|^2))$$

and we deduce that on  $\partial E_\varepsilon(p)$  we have

$$|X_\varphi|^{-2n} e^{z\varphi} \theta_\varphi \wedge (d\theta_\varphi)^{n-1} = \varepsilon^{-2n} e^{z\varphi(p)} (1 + R(z, \mathbf{x})) \theta_\varphi \wedge (d\theta_\varphi)^{n-1}, \quad (3.48)$$

where  $R_\varepsilon(z, \mathbf{x}) = O(|\mathbf{x}|)$  uniformly with respect to  $\mathbf{x} \in B_r(p)$  and  $z$  on the compacts of  $\mathbb{C}^*$ .

**Lemma 3.92.**

$$\lim_{\varepsilon \searrow 0} \varepsilon^{-2n} \int_{\partial E_\varepsilon(p)} \theta_\varphi \wedge (d\theta_\varphi)^{n-1} = \frac{(2\pi)^n}{\lambda_1 \cdots \lambda_n} \quad (3.49)$$

*Proof.*

$$\begin{aligned}
 &\varepsilon^{-2n} \int_{\partial E_\varepsilon(p)} \theta_\varphi \wedge (d\theta_\varphi)^{n-1} = \varepsilon^{-2n} \int_{E_\varepsilon(p)} (d\theta_\varphi)^n \\
 &\stackrel{(3.45)}{=} \frac{2^n n! \lambda_1 \cdots \lambda_n}{\varepsilon^{2n}} \int_{E_\varepsilon(p)} (1 + O(|\mathbf{x}|)) dx_1 \wedge \cdots \wedge dx_{2n} \\
 &= \text{vol}(E_\varepsilon(p)) \frac{2^n \lambda_1 \cdots \lambda_n}{n! \varepsilon^{2n}} + o(1).
 \end{aligned}$$

The volume of the ellipsoid  $E_\varepsilon(p)$  is

$$\text{vol}(E_\varepsilon(p)) = \frac{\pi^n \varepsilon^{2n}}{n!(\lambda_1 \cdots \lambda_n)^2}.$$

The equality (3.49) is now obvious.  $\square$

Using (3.49) and (3.48) in (3.47) we deduce

$$\int_M [e^{\alpha(z)}]_{2n} = \sum_{p \in \mathbf{Cr}_\varphi} \frac{(2\pi)^n}{z^n \prod_{k=1}^n \lambda_k(p)} e^{z\varphi(p)}. \quad (3.50)$$

The equality (3.44) implies that for any  $p \in \mathbf{Cr}_\varphi$  we have

$$\det_g H_{\varphi,p} = (-1)^n \prod_{k=1}^n \lambda_k(p)^2.$$

Denote by  $\ell(p)$  the cardinality of

$$\{k; \lambda_k(p) > 0\}.$$

Thus the index of the critical point  $p$  is  $\mu(p) = 2\ell(p)$  and it follows that the signature of  $H_{\varphi,p}$  is

$$\sigma(\varphi, p) = 2n - 4\ell(p) = 2n - 2\mu(p). \quad (3.51)$$

Observe that

$$|\det_g H_{\varphi,p}|^{\frac{1}{2}} = (-1)^{n-\ell(p)} \prod_{k=1}^n \lambda_k(p).$$

We can now rewrite (3.50) as

$$\begin{aligned} \frac{1}{n!} \int_M e^{z\varphi} \omega^n &= \sum_{p \in \mathbf{Cr}_\varphi} (-1)^{\ell(p)} \frac{(-2\pi)^n}{z^n |\det_g H_{\varphi,p}|^{\frac{1}{2}}} e^{z\varphi(p)} \\ &= \sum_{p \in \mathbf{Cr}_\varphi} (-1)^{\ell(p)} \frac{(2\pi \mathbf{i})^n}{(-\mathbf{i}z)^n |\det_g H_{\varphi,p}|^{\frac{1}{2}}} e^{z\varphi(p)} \\ &= \sum_{p \in \mathbf{Cr}_\varphi} \left( \frac{2\pi}{-\mathbf{i}z} \right)^n \frac{e^{\frac{\mathbf{i}\pi\sigma(\varphi,p)}{4}}}{|\det_g H_{\varphi,p}|^{\frac{1}{2}}} e^{z\varphi(p)} \end{aligned}$$

By letting  $z = \mathbf{i}t$  in the above equality we obtain the Duistermaat-Heckman identity (3.42).  $\square$

*Remark 3.93.* (a) Admittedly, the space  $\Omega_z^\bullet(M)$  and the operator  $d_z$  seem a bit strange at a first encounter. Their origin is in equivariant cohomology. Consider the space

$$\Omega_{\mathfrak{u}(1)}^\bullet = \mathbb{C}[z] \otimes \Omega^\bullet(M).$$

An element of  $\Omega_{\mathfrak{u}(1)}^\bullet(M)$  has the form

$$\alpha(z) = \sum_{k \geq 0} \alpha_k z^k,$$

where  $\alpha_k \in \Omega^\bullet(M)$  and  $\alpha_k = 0$  for all but finitely many  $k$ . We can regard  $\alpha(z)$  as a form on  $M$  depending smoothly on  $z$  and thus we have a natural embedding

$$\Omega_{\mathfrak{u}(1)}^\bullet(M) \subset \Omega_z^\bullet(M).$$

The variable  $z$  is assumed to have degree 2 so we can equip  $\Omega_{\mathfrak{u}(1)}^\bullet(M)$  with a new grading

$$\deg_z \alpha_k z^k = \deg \alpha_k + 2k.$$

Note that

$$d_z \Omega_{\mathfrak{u}(1)}^\bullet(M) \subset \Omega_{\mathfrak{u}(1)}^\bullet(M)$$

and

$$\deg_z d_z \alpha(z) = \widehat{\deg} \alpha(z) + 1.$$

Consider now the subspace  $\Omega_{S^1}^\bullet(M) \subset \Omega_{\mathfrak{u}(1)}^\bullet(M)$  consisting of forms

$$\sum_{k \geq 0} \alpha_k z^k$$

such that the forms  $\alpha_k$  are invariant with respect to the  $S^1$  action, i.e.,

$$L_{X_\varphi} \alpha_k = 0, \quad \forall k.$$

Note that  $d_z \Omega_{S^1}^\bullet(M) \subset \Omega_{S^1}^\bullet(M)$ , while Lemma 3.91(b) shows that  $d_z^2 = 0$  on  $\Omega_{S^1}^\bullet(M)$ . Thus  $(\Omega_{S^1}^\bullet(M), d_z)$  is a cochain complex. It is known as *Cartan's complex* and one can show that its cohomology is isomorphic as a  $\mathbb{C}[z]$ -module to the equivariant cohomology of  $M$  (over  $\mathbb{C}$ ). As a matter of fact, the Duistermaat-Heckman formula is a consequence of the Atiyah-Bott equivariant localization theorem, Theorem 3.80. For a proof and much more information on this topic we refer to the beautiful monograph [GS1]. In particular, this monograph also contains a more detailed discussion on the significance of the Duistermaat-Heckman theorem.

(b) Using (3.51) we can rewrite (3.42) as

$$\begin{aligned} \int_M e^{it\varphi(x)} dV_g(x) &= \sum_{p \in \mathbf{Cr}_\varphi} \left( \frac{2\pi i}{t} \right)^n \frac{i^{\mu(p)}}{|\det_g H_{\varphi,p}|^{\frac{1}{2}}} e^{it\varphi(p)} \\ &= \left( \frac{2\pi i}{t} \right)^n \sum_{k \geq 0} \frac{1}{k!} \left( \sum_{p \in \mathbf{Cr}_\varphi} \frac{i^{\mu(p)} \varphi(p)^k}{|\det_g H_{\varphi,p}|^{\frac{1}{2}}} \right) (it)^k. \end{aligned}$$

Since

$$\lim_{t \rightarrow 0} \int_M e^{it\varphi(x)} dV_g(x) = \text{vol}(M)$$

we deduce that for any  $m = 0, \dots, n-1$  we have

$$\sum_{p \in \mathbf{Cr}_\varphi} \frac{i^{\mu(p)} \varphi(p)^m}{|\det_g H_{\varphi,p}|^{\frac{1}{2}}} = 0,$$

and

$$\text{vol}(M) = \frac{(-2\pi)^n}{n!} \sum_{p \in \mathbf{Cr}_\varphi} \frac{i^{\mu(p)} \varphi(p)^n}{|\det_g H_{\varphi,p}|^{\frac{1}{2}}}.$$

Using (3.44) we can rewrite the above equalities as

$$\sum_{p \in \mathbf{Cr}_\varphi} \frac{i^{\mu(p)} \varphi(p)^m}{\prod_{k=1}^n |\lambda_k(p)|} = 0, \quad \forall m = 0, \dots, n-1, \quad (3.52a)$$

$$\text{vol}(M) = \frac{(-2\pi)^n}{n!} \sum_{p \in \mathbf{Cr}_\varphi} \frac{i^{\mu(p)} \varphi(p)^n}{\prod_{k=1}^n |\lambda_k(p)|}. \quad (3.52b)$$

□

**Example 3.94.** Let  $\mathbf{w} = (w_0, w_1, \dots, w_n) \in \mathbb{Z}^{n+1}$ , where

$$0 < w_1 < \dots < w_n, \quad w_0 = -\sum_{j=1}^n w_j.$$

The vector  $\mathbf{w}$  defines a hamiltonian  $S^1$ -action on  $\mathbb{C}\mathbb{P}^n$  given by (3.20)

$$e^{it} *_\mathbf{w} [0, \dots, z_n] = [e^{iw_0 t} z_0, \dots, e^{iw_n t} z_n]$$

with hamiltonian function given by (3.21)

$$\xi_\mathbf{w}([z_0, \dots, z_n]) = \frac{1}{|\mathbf{z}|^2} \sum_{j=0}^n w_j |z_j|^2.$$

The critical points of  $\xi_\mathbf{w}$  are the critical lines

$$\ell_j = [\delta_{j0}, \dots, \delta_{jn}] \in \mathbb{C}\mathbb{P}^n, \quad j = 0, \dots, n$$

Note that

$$\xi_\mathbf{w}(\ell_j) = w_j,$$

while the computations in Example 2.21 show that the Morse index of  $\ell_j$  is  $\mu(\ell_j) = 2j$ . The tangent space  $T_{\ell_j} \mathbb{C}\mathbb{P}^n$  can be identified with the subspace

$$V_j := \{ \zeta = \zeta_0, \dots, \zeta_n \in \mathbb{C}^{n+1}; \zeta_j = 0 \}$$

and the action of  $S^1$  on this subspace is given by

$$e^{it} * \zeta = \frac{d}{ds} \Big|_{s=0} e^{it} *_w [\ell_j + s\zeta] = (e^{it(w_0-w_j)} \zeta_0, \dots, e^{it(w_n-w_j)} \zeta_n) = V_j.$$

Using (3.52b) we deduce

$$\text{vol}(\mathbb{C}\mathbb{P}^n) = \frac{(-2\pi)^n}{n!} \sum_{j=0}^n \frac{(-1)^j w_j^n}{\prod_{k \neq j} |w_k - w_j|} = \frac{(2\pi)^n}{n!} \sum_{j=0}^n \frac{w_j^n}{\prod_{k \neq j} (w_j - w_k)}. \quad (3.53)$$

Similarly, using (3.52a) we deduce

$$\sum_{j=0}^n \frac{w_j^m}{\prod_{k \neq j} (w_j - w_k)} = 0, \quad \forall m = 0, \dots, n-1. \quad (3.54)$$

To find a simpler expression for the volume of  $\mathbb{C}\mathbb{P}^n$  we introduce the polynomial

$$P(z) = P_{\mathbf{w}}(z) = \prod_{j=0}^n (z - w_j).$$

we can rewrite the equalities (3.54) as

$$0 = \sum_{j=0}^n \frac{w_j^m}{P'(w_j)}, \quad \forall m = 0, \dots, n-1.$$

We deduce that

$$\sum_{j=0}^n \frac{Q(w_j)}{P'(w_j)} = 0, \quad (3.55)$$

for any polynomial  $Q$  of degree  $\leq n-1$ . Let

$$Q(z) := P'(z) - (n+1)z^n.$$

Then  $\deg Q \leq n-1$ , and (3.55) implies

$$(n+1) = \sum_{j=0}^n \frac{P'(w_j)}{P'(w_j)} = (n+1) \sum_{j=0}^n \frac{w_j^n}{P'(w_j)}.$$

This shows that

$$\sum_{j=0}^n \frac{w_j^n}{\prod_{k \neq j} (w_j - w_k)} = 1$$

and thus

$$\text{vol}(\mathbb{C}\mathbb{P}^n) = \frac{(2\pi)^n}{n!}.$$

For a different symplectic approach to the computation of  $\text{vol}(\mathbb{C}\mathbb{P}^n)$  we refer to Exercise 6.47.  $\square$





## Morse-Smale Flows and Whitney Stratifications

We have seen in Section 2.2 how to use a Morse function on a compact manifold  $M$  to reconstruct the manifold, up to a *diffeomorphism* via a sequence of elementary operations namely, handle attachments.

In this more theoretical chapter we want to describe a different approach to the reconstruction problem. Namely, the manifold  $M$  is the union of the unstable manifolds of the descending flow of a gradient like vector field. The strata are homeomorphic to open disks so it resembles a cellular decomposition. This was pointed out long ago by R. Thom, [Th]. This stratification can be quite unruly, but if the flow satisfies the Smale transversality condition, then this stratification enjoys remarkable regularity. The central result of this chapter shows that the descending flow satisfies the Smale transversality condition if and only if the stratification of  $M$  by unstable manifolds satisfies the so called *Whitney regularity* condition.

The first part of this chapter is a gentle introduction to the very technical subject of Whitney stratifications. The proofs of the main results of this theory are notoriously difficult and complex, and we decided that for a first encounter it is more productive not to include them, but instead provide as much intuition as possible. Some of the more elementary facts were left as exercises to the reader, and we have included generous references.

The central result in this chapter is contained in §4.3. It is based on and expands the author's recent investigations [Ni2]. To the best of our knowledge this result never appeared in book form.

In the remainder of the chapter we go deeper into the structure of a Morse flow. In Section 4.4 we investigate the spaces  $M(p, q)$  of tunnelings between two critical points  $p, q$ , i.e., the trajectories of the Morse flow that connect  $p$  to  $q$ . This is a smooth manifold of dimension  $\lambda(p) - \lambda(q) - 1$ . Using the elegant point of view pioneered by P. Kronheimer and T. Mrowka [KrMr, §18] we prove the classical result stating that  $M(p, q)$  admits a natural compactification  $\mathcal{M}(p, q)$  as a topological manifold with corners. This compactification parameterizes the so called *broken tunnelings* from  $p$  to  $q$ . In particular, if

$\lambda(p) - \lambda(q) = 2$ , then  $\mathcal{M}(p, q)$  is a 1-dimensional manifold with possibly non-empty boundary.

In Section 4.5 we give a description of the Morse-Floer complex in terms of tunnelings. The boundary operator  $\partial$  is defined in terms of signed counts of tunnelings between critical points  $p, q$  such that  $\lambda(p) - \lambda(q) = 1$ . The main result of this section states that the boundary operator thus defined is indeed a boundary operator, i.e.,  $\partial^2 = 0$ . Our proof seems to be new, and it is based on the equivalence between the Smale transversality and the Whitney transversality. During this we reveal in quite an explicit fashion the intimate connections between the compactifications  $\mathcal{M}(p, q)$  in §4.4 and the singularities of the stratification by unstable manifolds.

### 4.1 The Gap Between Two Vector Subspaces

The definition of the Whitney regularity conditions uses a notion of distance between two subspaces. The goal of this section is to introduce this notion and discuss some of its elementary properties.

Suppose that  $E$  is a real finite dimensional Euclidean space. We denote by  $(\bullet, \bullet)$  the inner product on  $E$ , and by  $|\bullet|$  the associated Euclidean norm. We define as usual the norm of a linear operator  $A : E \rightarrow E$  by the equality

$$\|A\| := \sup\{|Ax|; x \in E, |x| = 1\}.$$

The finite dimensional vector space  $\text{End}(E)$  of linear operators  $E \rightarrow E$  is equipped with an inner product

$$\langle A, B \rangle := \text{tr}(AB^*),$$

and we set

$$|A| := \sqrt{\langle A, A \rangle} = \sqrt{\text{tr}(AA^*)} = \sqrt{\text{tr}(A^*A)}.$$

Since  $E$  is finite dimensional, there exists a constant  $C > 1$ , depending only on the dimension of  $E$ , such that

$$\frac{1}{C}|A| \leq \|A\| \leq C|A|. \quad (4.1)$$

If  $U$  and  $V$  are two subspaces of  $E$ , then we define the *gap* between  $U$  and  $V$  to be the real number

$$\begin{aligned} \delta(U, V) &:= \sup\{\text{dist}(u, V); u \in U, |u| = 1\} \\ &= \sup_u \inf_v \{|u - v|; u \in U, |u| = 1, v \in V\}. \end{aligned}$$

If we denote by  $P_{V^\perp}$  the orthogonal projection onto  $V^\perp$ , then we deduce

$$\begin{aligned} \delta(U, V) &= \sup_{|u|=1} |P_{V^\perp}u| = \|P_{V^\perp}P_U\| \\ &= \|P_U - P_V P_U\| = \|P_U - P_U P_V\|. \end{aligned} \quad (4.2)$$

Note that

$$\delta(V^\perp, U^\perp) = \delta(U, V). \quad (4.3)$$

Indeed,

$$\begin{aligned} \delta(V^\perp, U^\perp) &= \|P_{V^\perp} - P_{U^\perp}P_{V^\perp}\| = \|\mathbb{1} - P_V - (\mathbb{1} - P_U)(\mathbb{1} - P_V)\| \\ &= \|P_U - P_U P_V\| = \delta(U, V). \end{aligned}$$

We deduce that

$$0 \leq \delta(U, V) \leq 1, \quad \forall U, V.$$

Let us point out that

$$\delta(U, V) < 1 \iff \dim U \leq \dim V, \quad U \cap V^\perp = 0.$$

Note that this implies that the gap is *asymmetric* in its variables, i.e., we cannot expect  $\delta(U, V) = \delta(V, U)$ . Set

$$\hat{\delta}(U, V) := \delta(U, V) + \delta(V, U).$$

**Proposition 4.1.** (a) For any vector subspaces  $U, V \subset E$  we have

$$\|P_U - P_V\| \leq \hat{\delta}(U, V) \leq 2\|P_U - P_V\|.$$

(b) For any vector subspaces  $U, V, W$  such that  $V \subset W$  we have

$$\delta(U, V) \geq \delta(U, W), \quad \delta(V, U) \leq \delta(W, U).$$

In other words, the function  $(U, V) \mapsto \delta(U, V)$  is increasing in the first variable, and decreasing in the second variable.

*Proof.* (a) We have

$$\begin{aligned} \hat{\delta}(U, V) &= \|P_U - P_U P_V\| + \|P_V - P_V P_U\| \\ &= \|P_U(P_U - P_V)\| + \|P_V(P_V - P_U)\| \leq 2\|P_U - P_V\|, \end{aligned}$$

and

$$\begin{aligned} \|P_U - P_V\| &\leq \|P_U - P_U P_V\| + \|P_U P_V - P_V\| \\ &= \|P_U - P_U P_V\| + \|P_V - P_V P_U\| = \hat{\delta}(U, V). \end{aligned}$$

(b) Observe that for all  $u \in U$ ,  $|u| = 1$  we have

$$\text{dist}(u, V) \geq \text{dist}(u, W) \implies \delta(U, V) \geq \delta(U, W).$$

Since  $V \subset W$  we deduce

$$\sup_{v \in V \setminus \{0\}} \frac{1}{|v|} \operatorname{dist}(v, U) \leq \sup_{w \in W \setminus \{0\}} \frac{1}{|w|} \operatorname{dist}(w, U). \quad \square$$

We denote by  $\operatorname{Gr}_k(E)$  the Grassmannian of  $k$ -dimensional subspaces of  $E$  equipped with the metric

$$\operatorname{dist}(U, V) := \|P_U - P_V\|.$$

The Grassmannian  $\operatorname{Gr}_k(E)$  is a compact (semialgebraic) subset of  $\operatorname{End}(E)$ . We set

$$\operatorname{Gr}(E) := \bigcup_{k=0}^{\dim E} \operatorname{Gr}_k(E).$$

Let  $\operatorname{Gr}^k(E)$  denote the Grassmannian of codimension  $k$  subspaces. For any subspace  $U \subset E$  we set

$$\operatorname{Gr}(E)_U := \{V \in \operatorname{Gr}(E); V \supset U\}, \quad \operatorname{Gr}(E)^U := \{V \in \operatorname{Gr}(E); V \subset U\}.$$

Note that we have a metric preserving involution

$$\operatorname{Gr}(E) \ni V \mapsto V^\perp \in \operatorname{Gr}(E),$$

such that

$$\operatorname{Gr}_k(E)_U \longleftrightarrow \operatorname{Gr}^k(E)^{U^\perp}, \quad \operatorname{Gr}^k(E)_U \longleftrightarrow \operatorname{Gr}_k(E)^{U^\perp}.$$

Using (3.6) we deduce that for any  $1 \leq j \leq k$ , and any  $U \in \operatorname{Gr}_j(E)$ , there exists a constant  $c > 1$  such that, for every  $L \in \operatorname{Gr}_k(E)$  we have

$$\frac{1}{c} \operatorname{dist}(L, \operatorname{Gr}_k(E)_U)^2 \leq |P_U - P_U P_L|^2 \leq c \operatorname{dist}(L, \operatorname{Gr}_k(E)_U)^2.$$

The constant  $c$  depends on  $j, k, \dim E$ , and a priori it could also depend on  $U$ . Since the quantities entering into the above inequality are invariant with respect to the action of the orthogonal group  $O(E)$ , and the action of  $O(E)$  on  $\operatorname{Gr}_j(E)$  is transitive, we deduce that the constant  $c$  is independent on the plane  $U$ . The inequality (4.1) implies the following result.

**Proposition 4.2.** *Let  $1 \leq j \leq k \leq \dim E$ . There exists a positive constant  $c > 1$  such that, for any  $U \in \operatorname{Gr}_j(E)$ ,  $V \in \operatorname{Gr}_k(E)$  we have*

$$\frac{1}{c} \operatorname{dist}(V, \operatorname{Gr}_k(E)_U) \leq \delta(U, V) \leq c \operatorname{dist}(V, \operatorname{Gr}_k(E)_U). \quad \square$$

**Corollary 4.3.** *For every  $1 \leq k \leq \dim E$  there exists a constant  $c > 1$  such that, for any  $U, V \in \operatorname{Gr}_k(E)$  we have*

$$\frac{1}{c} \operatorname{dist}(U, V) \leq \delta(U, V) \leq c \operatorname{dist}(U, V).$$

*Proof.* In Proposition 4.2 we make  $j = k$  and we observe that  $\text{Gr}_k(E)_U = \{U\}$ ,  $\forall U \in \text{Gr}_k(E)$ .  $\square$

We would like to describe a few simple geometric techniques for estimating the gap between two vector subspaces. Suppose that  $U, V$  are two vector subspaces of the Euclidean space  $E$  such that

$$\dim U \leq \dim V \text{ and } \delta(U, V) < 1.$$

As remarked earlier, the condition  $\delta(U, V) < 1$  can be rephrased as  $U \cap V^\perp = 0$ , or equivalently,  $U^\perp + V = E$ , i.e., the subspace  $V$  intersects  $U^\perp$  transversally. Hence

$$U \cap \ker P_V = 0.$$

Denote by  $S$  the orthogonal projection of  $U$  on  $V$ . We deduce that the restriction of  $P_V$  to  $U$  defines a bijection  $U \rightarrow S$ . Hence  $\dim S = \dim U$ , and we can find a linear map  $h : S \rightarrow V^\perp$  whose graph is  $U$ , i.e.,

$$U = \{s + h(s); s \in S\}.$$

Next, denote by  $T$  the orthogonal complement of  $S$  in  $V$  (see Figure 4.1),  $T := S^\perp \cap V$ , and by  $W$  the subspace  $W := U + T$ .

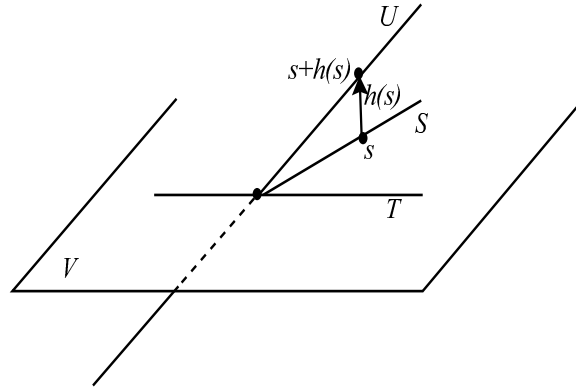

**Fig. 4.1.** Computing the gap between two subspaces.

**Lemma 4.4.**  $T = U^\perp \cap V$ .

*Proof.* Observe first that

$$(S + U) \subset T^\perp. \tag{4.4}$$

Indeed, let  $t \in T$ . Any element in  $S + U$  can be written as a sum

$$s + u = s + s' + h(s'), \quad s, s' \in S.$$

Then  $(s + s') \perp t$  and  $h(s') \perp t$ , because  $h(s') \in V^\perp$ . Hence  $T \subset U^\perp \cap S^\perp \subset U^\perp$ . On the other hand,  $T \subset V$  so that  $T \subset U^\perp \cap V$ . Since  $V$  intersects  $U^\perp$  transversally we deduce

$$\dim(U^\perp \cap V) = \dim U^\perp + \dim V - \dim E = \dim V - \dim U = \dim T. \quad \square$$

**Lemma 4.5.**  $\delta(W, V) = \delta(U, V) = \delta(U, S)$ .

*Proof.* The equality  $\delta(U, V) = \delta(U, S)$  is obvious. Let  $w_0 \in W$  such that  $|w_0| = 1$  and

$$\text{dist}(w_0, V) = \delta(W, V).$$

To prove the lemma it suffices to show that  $w_0 \in U$ . We write

$$w_0 = u_0 + t_0, \quad u_0 \in U, \quad t_0 \in T, \quad |u_0|^2 + |t_0|^2 = 1.$$

We have to prove that  $t_0 = 0$ . We can refine some more the above decomposition of  $w_0$  by writing

$$u_0 = s_0 + h(s_0), \quad s_0 \in S.$$

Then  $P_V w_0 = s_0 + t_0$ . We know that for any  $u \in U, t \in T$  such that  $|u|^2 + |t|^2 = 1$  we have

$$|u_0^2 - P_V u_0|^2 = |w_0 - P_V w_0|^2 \geq |(u + t) - P_V(u + t)|^2 = |u - P_V u|^2.$$

If in the above inequality we choose  $t = 0$  and  $u = \frac{1}{|u_0|}$  we deduce

$$|u_0^2 - P_V u_0|^2 \geq \frac{1}{|u_0|^2} |u_0^2 - P_V u_0|^2.$$

Hence  $|u_0| \geq 1$  and since  $|u_0|^2 + |t_0|^2 = 1$  we deduce  $t_0 = 0$ .  $\square$

The next result summarizes the above observations.

**Proposition 4.6.** *Suppose  $U$  and  $V$  are two subspaces of the Euclidean space  $E$  such that  $\dim U \leq \dim V$  and  $V$  intersects  $U^\perp$  transversally. Set*

$$T := V \cap U^\perp, \quad W := U + T,$$

and denote by  $S$  the orthogonal projection of  $U$  on  $V$ . Then

$$S = T^\perp \cap V,$$

$$\dim U = \dim S, \quad \dim W = \dim V,$$

and

$$\delta(W, V) = \delta(U, V) = \delta(U, S). \quad \square$$

**Proposition 4.7.** *Suppose that  $E$  is a finite dimensional Euclidean vector space. There exists a constant  $C > 1$ , depending only on the dimension of  $E$ , such that, for any subspaces  $U \subset E$ , and any linear operator  $S : U \rightarrow U^\perp$ , we have*

$$\delta(\Gamma_S, U) = \|S\|(1 + \|S\|^2)^{-1/2}, \tag{4.5}$$

and

$$\frac{1}{C}\|S\|(1 + \|S\|^2)^{-1/2} \leq \delta(U, \Gamma_S) \leq C\|S\|(1 + \|S\|^2)^{-1/2}, \tag{4.6}$$

where  $\Gamma_S \subset U + U^\perp = E$  is the graph of  $S$  defined by

$$\Gamma_S := \{ u + Su \in E; u \in U \}.$$

*Proof.* Observe that

$$\delta(\Gamma_S, U)^2 = \sup_{u \in U \setminus \{0\}} \frac{|Su|^2}{|u|^2 + |Su|^2} = \sup_{u \in U \setminus \{0\}} \frac{(S^*Su, u)}{|u|^2 + (S^*Su, u)}.$$

Choose an orthonormal basis  $e_1, \dots, e_k$  of  $U$  consisting of eigenvectors of  $S^*S$ ,

$$S^*Se_i = \lambda_i e_i, \quad 0 \leq \lambda_1 \leq \dots \leq \lambda_k.$$

Observe that  $\|S^*S\| = \lambda_k$ . We deduce

$$\begin{aligned} \delta(\Gamma_S, U)^2 &= \sup \left\{ \sum_i \lambda_i u_i^2; \sum_i (1 + \lambda_i) u_i^2 = 1 \right\} \\ &= \sup \left\{ 1 - \sum_i u_i^2; \sum_i (1 + \lambda_i) u_i^2 = 1 \right\} \\ &= 1 - \inf \left\{ \sum_i u_i^2; \sum_i (1 + \lambda_i) u_i^2 = 1 \right\} \\ &= 1 - \frac{1}{1 + \lambda_k} = \frac{\|S^*S\|}{1 + \|S^*S\|} = \frac{\|S\|^2}{1 + \|S\|^2}. \end{aligned}$$

This proves (4.5). The inequality (4.6) follows from (4.5) combined with Corollary 4.3. □

Set

$$\mathcal{P}(E) := \{ (U, V) \in \text{Gr}(E) \times \text{Gr}(E); \dim U \leq \dim V, V \pitchfork U^\perp \}.$$

For every pair  $(U, V) \in \mathcal{P}(E)$  we denote by  $\mathcal{S}_V(U)$  the *shadow* of  $U$  on  $V$ , i.e., the orthogonal projection of  $U$  on  $V$ . Let us observe that

$$U^\perp \cap \mathcal{S}_V(U) = 0.$$

Indeed, we have

$$U^\perp \cap \mathcal{S}_V(U) \subset T := U^\perp \cap V \implies U^\perp \cap \mathcal{S}_V(U) \subset \mathcal{S}_V(U) \cap T,$$

and Proposition 4.6 shows that  $\mathcal{S}_V(U)$  is the orthogonal complement of  $T$  in  $V$ . Since  $\dim U = \dim \mathcal{S}_V(U)$ , we deduce that  $\mathcal{S}_V(U)$  can be represented as the graph of a linear operator

$$\mathcal{M}_V(U) : U \rightarrow U^\perp$$

which we will call the *slope* of the pair  $(U, V)$ . From Proposition 4.6 we deduce

$$\delta(\mathcal{S}_V(U), U) = \frac{\|\mathcal{M}_V(U)\|}{(1 + \|\mathcal{M}_V(U)\|^2)^{1/2}},$$

or equivalently,

$$\|\mathcal{M}_V(U)\| = \frac{\delta(\mathcal{S}_V(U), U)}{(1 - \delta(\mathcal{S}_V(U), U)^2)^{1/2}}.$$

**Corollary 4.8.** *There exists a constant  $C > 1$ , which depends only on the dimension of  $E$  such that, for every pair  $(U, V) \in \mathcal{P}(E)$  we have*

$$\frac{1}{C} \frac{\|\mathcal{M}_V(U)\|}{(1 + \|\mathcal{M}_V(U)\|^2)^{1/2}} \leq \delta(U, V) \leq C \frac{\|\mathcal{M}_V(U)\|}{(1 + \|\mathcal{M}_V(U)\|^2)^{1/2}}.$$

*Proof.* Use the equality  $\delta(U, V) = \delta(U, \mathcal{S}_V(U))$  and Proposition 4.7.  $\square$

For any symmetric endomorphism  $A$  of an Euclidean space we denote by  $m_+(A)$  the smallest positive eigenvalue of  $A$ , and by  $m_-(A)$  the smallest positive eigenvalue of  $-A$ .

**Proposition 4.9.** *Suppose  $A : E \rightarrow E$  is an invertible symmetric operator, and  $U$  is the subspace of  $E$  spanned by the positive eigenvectors  $A$ . Then, for every subspace  $V \subset E$ , such that  $(U, V) \in \mathcal{P}(E)$ , we have*

$$\begin{aligned} \delta(U, e^{tA}V) &\leq e^{-(m_+(A)+m_-(A))t} \|\mathcal{M}_V(U)\| \\ &= e^{-(m_+(A)+m_-(A))t} \frac{\delta(\mathcal{S}_V(U), U)}{(1 - \delta(\mathcal{S}_V(U), U)^2)^{1/2}}. \end{aligned}$$

*Proof.* Denote by  $L$  the intersection of  $V$  with  $U^\perp$ . We have an orthogonal decomposition

$$V = L + \mathcal{S}_V(U),$$

and if we write  $\mathcal{M} := \mathcal{M}_V(U) : U \rightarrow U^\perp$ , then we obtain



$$V = \{ \ell + u + \mathcal{M}u; \ell \in L, u \in U \}.$$

Using the orthogonal decomposition  $E = U + U^\perp$  we can describe  $A$  in the block form

$$A = \begin{bmatrix} A_+ & 0 \\ 0 & A_- \end{bmatrix},$$

where  $A_+$  denotes the restriction of  $A$  to  $U$ , and  $A_-$  denotes the restriction of  $A$  to  $U^\perp$ .

Set  $V_t := e^{tA}V$ ,  $L_t := V_t \cap U^\perp$ . Since  $U^\perp$  is  $A$ -invariant, we deduce that  $L_t = e^{tA_-}L$ , so that

$$\begin{aligned} V_t &= \{ e^{tA_-}\ell + e^{tA_+}u + e^{tA_-}\mathcal{M}u; \ell \in L, u \in U \} \\ &= \{ e^{tA_-}\ell + u + e^{tA_-}\mathcal{M}e^{-tA_+}u; \ell \in L, u \in U \}. \end{aligned}$$

We deduce that for every  $u \in U$  the vector  $u + e^{tA_-}\mathcal{M}e^{-tA_+}u$  belongs to  $V_t$ . Hence

$$\begin{aligned} \delta(U, V_t) &\leq \sup_{|u|=1} |e^{tA_-}\mathcal{M}e^{-tA_+}u| \\ &= \|e^{tA_-}\mathcal{M}e^{-tA_+}\| \leq e^{-(m_+(A)+m_-(A))t} \|\mathcal{M}\|. \quad \square \end{aligned}$$

**Corollary 4.10.** *Let  $A$  and  $U$  as above. Fix  $\ell > \dim U$  and consider a compact subset  $K \subset \text{Gr}_\ell(E)$  such that any  $V \in K$  intersects  $U^\perp$  transversally. Then there exists a positive constant, depending only on  $K$  and  $\dim E$  such that*

$$\delta(U, e^{tA}V) \leq C e^{-(m_+(A)+m_-(A))t}, \quad \forall V \in K. \quad \square$$

Later we will need the following elementary result whose proof is left to the reader as an exercise (Exercise 6.35).

**Lemma 4.11.** *Suppose  $V$  is a subspace in  $\mathbb{R}^m$  and  $(T_n)$  is a sequence in  $\text{Gr}_\ell(\mathbb{R}^m)$  which converges to a subspace  $T \in \text{Gr}_\ell(\mathbb{R}^m)$  that intersects  $V$  transversally. Then for all sufficiently large  $T_n$  intersects  $V$  transversally and*

$$\lim_{n \rightarrow \infty} \delta(T \cap V, T_n \cap V) = 0. \quad \square$$

## 4.2 The Whitney Regularity Conditions

For any subset  $S$  of a topological space  $X$  we will denote by  $\mathbf{cl}(S)$  its closure. We will describe an important category of topological spaces made up of smooth pieces (called *strata*) glued together according to some rules imposing a certain uniformity. Such rules are encoded by the so called *Whitney regularity conditions*.

**Definition 4.12.** Suppose  $X, Y$  are two disjoint smooth submanifolds<sup>1</sup> of the Euclidean space  $E$ .

(a) We say that the pair  $(X, Y)$  satisfies the Whitney regularity condition (a) at  $x_0 \in X \cap \mathbf{cl}(Y)$  if, for any sequence  $y_n \in Y$  such that

- $y_n \rightarrow x_0$ ,
- the sequence of tangent spaces  $T_{y_n} Y$  converges to the subspace  $T_\infty$ ,

we have  $T_{x_0} X \subset T_\infty$ .

(b) We say that the pair  $(X, Y)$  satisfies the Whitney regularity condition (b) at  $x_0 \in X \cap \mathbf{cl}(Y)$  if, for any sequence  $(x_n, y_n) \in X \times Y$  such that

- $x_n, y_n \rightarrow x_0$ ,
- the one dimensional subspaces  $\ell_n = \mathbb{R}(y_n - x_n)$  converge to the line  $\ell_\infty$ ,
- the sequence of tangent spaces  $T_{y_n} Y$  converges to the subspace  $T_\infty$ ,

we have  $\ell_\infty \subset T_\infty$ , that is,  $\delta(\ell_\infty, T_\infty) = 0$ .

(c) The pair  $(X, Y)$  is said to satisfy the regularity condition (a) or (b) along  $X$ , if it satisfies this condition at any  $x \in X \cap \mathbf{cl}(Y)$ . □

**Example 4.13.** (a) It is perhaps instructive to give examples when the one of the regularity conditions (a) or (b) fails. Consider first the *Whitney umbrella*  $W$  depicted in Figure 4.2.

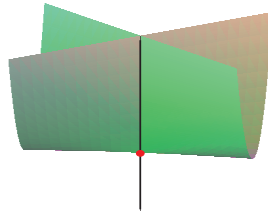

**Fig. 4.2.** Whitney umbrella  $x^2 = zy^2$ .

This surface contains the origin  $O$ , and two lines, the  $y$ -axis and the  $z$ -axis. The surface  $W$  is singular along the  $z$ -axis. Let  $X$  denote  $z$ -axis and  $Y$  the

<sup>1</sup> Typically, these submanifolds are not properly embedded. For example, the unit circle in plane with a point removed is a submanifold of the plane.

complement of  $X$  in  $W$ , so that  $X \subset \mathbf{cl}(Y)$ . We claim that the pair  $(X, Y)$  does not satisfy the regularity condition (a) at  $O$ . Along the  $y$ -axis we have

$$\nabla w = (2x, -2zy, -y^2) = (0, 0, -y^2).$$

If we choose a sequence of points  $p_n \rightarrow 0$  along the  $y$ -axis then we see  $T_{p_n}Y$  converges to the plane

$$T = \{z = 0\} \not\subseteq T_OX.$$

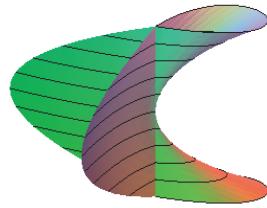

**Fig. 4.3.** The Whitney cusp  $y^2 + x^3 - z^2x^2 = 0$ .

(b) Consider the *Whitney cusp* depicted in Figure 4.3, that is, the real algebraic surface  $U \subset \mathbb{R}^3$  described by the equation

$$f(x, y, z) = y^2 + x^3 - z^2x^2 = 0.$$

The vertical line visible in Figure 4.3 is the  $z$ -axis. Clearly the Whitney cusp is singular along this line. The surface has a "saddle" at the origin. Denote by  $X$  the  $z$ -axis, and by  $Y$  its complement in the Whitney cusp. We claim that  $(X, Y)$  is (a)-regular at  $O$ , but is not (b)-regular at this point.

To prove the (a)-regularity we have to show that

$$\frac{|\partial_z f(p)|}{|\nabla f(p)|} \rightarrow 0 \quad \text{if } p = (x, y, z) \rightarrow O \text{ along } U. \tag{4.7}$$

Observe that

$$\nabla f = (3x^2 - 2xz^2, 2y, 2zx^2)$$

Obviously (4.7) holds for all sequences  $p_n = (x_n, y_n, z_n) \in U$  such that  $z_n = 0, \forall n \gg 1$ . If  $(x, y, z) \rightarrow 0$  along  $U \cap \{z \neq 0\}$  then  $y^2 = x^2(z^2 - x)$

$$|\nabla f|^2 = 4|x^2z|^2 + 4|y|^2 + |3x^2 - 2xz^2|^2$$

$$= 4|x^2z|^2 + 4|x|^2|z^2 - x|^2 + |x|^2|3x - 2z^2|^2$$

Then

$$\begin{aligned} \frac{|\nabla f|^2}{|\partial_z f|^2} &= 1 + \frac{4|x|^2|z^2 - x|^2}{4|x^2z|^2} + \frac{|x|^2|3x - 2z^2|^2}{4|x^2z|^2} \\ &= 1 + \frac{1}{4} \left| \frac{z^2 - x}{xz} \right|^2 + \frac{|x|^2|3x - 2z^2|^2}{4|x^2z|^2} \\ &= 1 + \frac{1}{4} \left| \frac{z}{x} - \frac{1}{z} \right|^2 + \left| \frac{z}{x} - \frac{3}{2z} \right|^2 \xrightarrow{(x,z) \rightarrow 0} \infty. \end{aligned}$$

To show that the (b)-condition is violated at  $O$  we need to find a sequence

$$U \ni p_n = (x_n, y_n, z_n) \rightarrow 0$$

such that

$$T_{p_n}U \rightarrow T, \quad \lim_{n \rightarrow \infty} \mathfrak{h}(p_n) = \mathfrak{h}, \quad \text{and } \mathfrak{h} \not\subset T, \quad (4.8)$$

where  $\mathfrak{h}(p_n)$  denotes the line spanned by the vector  $(x_n, y_n, 0)$ . Thus, we need to find a sequence  $p_n$  such that  $\frac{1}{|\nabla f(p_n)|} \nabla f(p_n)$  is convergent and

$$\lim_{n \rightarrow \infty} \frac{x_n \partial_x f(p_n) + y_n \partial_y f(p_n)}{|\nabla f(p_n)| \cdot \sqrt{|x_n|^2 + |y_n|^2}} \neq 0.$$

We will seek such sequences along paths in  $U$  which end up at  $O$ . Look at the parabola

$$C = \{y = 0\} \cap U = \{x = z^2; y = 0, y \neq 0\} = \{(z^2, 0, z); z \neq 0\} \subset U.$$

Along  $C$  line  $\mathfrak{h}(z^2, 0, 0)$  is the line generated by the vector  $\mathbf{e}_1 = (1, 0, 0)$  and we have

$$\nabla f = (z^4, 0, z^5) \implies |\nabla f| = |z|^4(1 + O(|z|))$$

We conclude that along this parabola the tangent plane  $T_p U$  converges to the plane perpendicular to  $\mathbf{e}_1$  which shows that the (b)-condition is violated by the sequence converging to zero along  $C$ .  $\square$

*Remark 4.14.* The Whitney condition (a) is weaker than (b) in the sense that (b)  $\implies$  (a). The Whitney cusp example shows that (b) is not equivalent to (a).  $\square$

In applications it is convenient to use a regularity condition slightly weaker than the condition (b). To describe it suppose that the manifolds  $X, Y$  are as above,  $X \subset \mathbf{cl}(Y) \setminus Y$ , and let  $p \in X \cap \mathbf{cl}(Y)$ . We can choose coordinates in a neighborhood  $U$  of  $p$  in  $E$  such that  $U \cap X$  can be identified with an open subset of an affine plane  $L \subset E$ . We denote by  $P_L$  the orthogonal projection onto  $L$ .

We say that  $(X, Y)$  satisfies the condition (b') at  $p$  if, for any sequence  $y_n \rightarrow p$  such that the  $T_{y_n}Y$  converges to some  $T_\infty$ , and the one dimensional subspace  $\ell_n := \mathbb{R}(y_n - P_L y_n)$  converges to the 1-dimensional subspace  $\ell_\infty$ , we have

$$\ell_\infty \subset T_\infty, \text{ i.e., } \gamma(\ell_\infty, T_\infty) = 0.$$

The proof of the following elementary result is left to the reader as an exercise.

**Proposition 4.15.**  $(a) + (b') \implies (b)$ . □

To delve deeper into the significance of the Whitney condition we need to introduce a very precise notion of tubular neighborhood.

**Definition 4.16.** Suppose  $X$  is a smooth submanifold of the smooth manifold  $M$ .<sup>2</sup> A tubular neighborhood of  $X \hookrightarrow M$  (or a tube around  $X$  in  $M$ ) is a quadruple  $T = (\pi, E, \epsilon, \phi)$ , where  $E \rightarrow X$  is a real vector bundle equipped with a metric,  $\epsilon : X \rightarrow (0, \infty)$  is a smooth function, and if we set

$$B_\epsilon := \{(v, x) \in E; x \in X, \|v\|_x < \epsilon(x)\},$$

then  $\phi$  is a diffeomorphism from  $B_\epsilon \rightarrow X$  onto an open subset of  $X$  such that the diagram below is commutative,

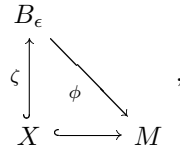

where  $\zeta$  denotes the zero section of  $E$ . We set  $|T| := \phi(B_\epsilon)$ . The function  $\epsilon$  is called the width function of the tube. □

Given a tubular neighborhood  $T = (\pi, E, \epsilon, \phi)$  we get a natural projection

$$\pi_T : |T| \rightarrow X.$$

Moreover the function  $\rho(v, x) = \|v\|_x^2$  induces a smooth function  $\rho_T : |T| \rightarrow X$ . We say that  $\pi_T$  is projection and  $\rho_T$  is the radial function associated to the tubular neighborhood  $T$ . We get a submersion

$$(\pi_T, \rho_T) : |T| \setminus X \rightarrow X \times \mathbb{R}.$$

For any function  $\alpha : X \rightarrow (0, \infty)$  such that  $\alpha(x) < \epsilon(x), \forall x \in X$  we set

$$|T|_\alpha = \{y \in |T|; \rho_T(y) \leq \alpha(\pi_T(y))^2\}.$$

---

<sup>2</sup> The submanifold  $X$  need not be closed in  $M$ .

Via the diffeomorphism  $\phi$  we can identify  $|T|_\alpha$  with the bundle of (closed) disks bundle  $\mathbf{cl}(B_\alpha)$ . Its boundary  $\partial|T|_\alpha$  is sphere bundle  $\partial B_{r_\varepsilon} \rightarrow X$ . The restriction of a tubular neighborhood of  $U$  to an *open* subset of  $X$  is defined in an obvious fashion.

**Definition 4.17.** *Suppose that  $T$  is a tubular neighborhood of  $X \hookrightarrow M$  and  $f : M \rightarrow Y$  is a map. We say that  $f$  is compatible with  $T$  if the restriction of  $f$  to  $|T|$  is constant along the fibers of  $\pi_T$ , i.e., the diagram below is commutative*

$$\begin{array}{ccc}
 |T| & & \\
 \pi_T \downarrow & \searrow f & \\
 X & \xrightarrow{f} & Y
 \end{array}
 \quad \square$$

We have the following existence result [GWPL, Mat].

**Theorem 4.18 (Tubular Neighborhood Theorem).** *Suppose  $f : M \rightarrow N$  is a smooth map between smooth manifolds and  $X \hookrightarrow M$  a smooth submanifold of  $M$  such that  $f|_X$  is a submersion. Suppose*

$$W \hookrightarrow V \hookrightarrow X$$

*are open subsets such that the closure of  $W$  in  $X$  lies inside  $V$ , and  $T_0$  is a smooth tubular neighborhood of  $V \hookrightarrow M$  which is compatible with  $f$ .*

*Then there exists a tubular neighborhood  $T$  of  $X \hookrightarrow M$  satisfying the following conditions.*

- (a) *The tube  $T$  is compatible with  $f$ .*
- (b)  *$T|_W \subset T_0|_W$ .*

□

The Whitney regularity condition interacts nicely with the concept of tubes. The proof of the following result is left to the reader as an exercise. We strongly recommend to the reader to attempt a proof of this result since it will help him/her understand what is hiding behind the regularity conditions.

**Lemma 4.19.** *Suppose  $X, Y \subset \mathbb{R}^m$  are smooth submanifolds such that  $X \subset \mathbf{cl}(Y)$  and  $T = (\pi, E, \varepsilon, \phi)$  is a tube around  $X$  in  $\mathbb{R}^m$ . The the following hold.*

- (a) *If the pair  $(X, Y)$  satisfies Whitney's condition (a) along  $X$ , then there exists a function  $\alpha : X \rightarrow (0, \infty)$ ,  $\alpha < \varepsilon$ , such that the restriction  $\pi_T : Y \cap |T|_\alpha \cap Y \rightarrow X$  is a submersion.*
- (b) *If the pair  $(X, Y)$  satisfies Whitney's condition (b) along  $X$ , then there exists a function  $\alpha : X \rightarrow (0, \infty)$ ,  $\alpha < \varepsilon$ , such that the induced map*

$$\pi_T \times \rho_T : |T|_\alpha \cap Y \rightarrow X \times (0, \infty)$$

*is a submersion.*

□

*Remark 4.20.* It is useful to rephrase the above result in more geometric terms. Let  $c = m - \dim X = \text{codim } X$ . For any  $r > 0$  and  $x \in X$  we denote by  $D_r^c(x)$  the  $c$ -dimensional disk  $D_r^c(x)$  of radius  $r$ , centered at  $x$  and perpendicular to  $T_x X$ .

The first statement in the above lemma shows that if  $(X, Y)$  satisfies the condition (a) along  $X$ , then for any  $x \in X$  and any  $r < \alpha(x)$  the normal disk  $D_r^c(x)$  intersects  $Y$  transversally. If  $(X, Y)$  satisfies the condition (b) along  $X$ , then for any  $x \in X$  and any  $r < \alpha(x)$ , then both the disk  $D_r^c(x)$  and its boundary  $\partial D_r^c(x)$  intersect  $Y$  transversally.  $\square$

In a certain sense the above transversality statements characterize the Whitney regularity condition (b). More precisely, we have the following geometric characterization of the Whitney condition (b).

**Proposition 4.21 (Trotman).** *Suppose  $(X, Y)$  is a pair of  $C^1$  submanifolds of the  $\mathbb{R}^N$ ,  $\dim X = m$ . Assume  $X \subset \text{cl}(Y) \setminus Y$ . Then the pair  $(X, Y)$  satisfies the Whitney regularity condition (b) along  $X$  if and only if, for any open set  $U \subset \mathbb{R}^N$ , and any  $C^1$ -diffeomorphism  $\Psi : U \rightarrow V$ , where  $V$  is an open subset of  $\mathbb{R}^N$ , such that*

$$\Psi(U \cap X) \subset \mathbb{R}^m \oplus 0 \subset \mathbb{R}^N,$$

the map

$$\Psi(Y \cap U) \longrightarrow \mathbb{R}^m \times (0, \infty), \quad y \longmapsto (\text{proj}(y), \text{dist}(y, \mathbb{R}^m)^2),$$

is a submersion, where  $\text{proj} : \mathbb{R}^N \rightarrow \mathbb{R}^m$  denotes the canonical orthogonal projection.  $\square$

For a proof we refer to the original source, [Tr].

**Definition 4.22.** *Suppose  $X$  is a subset of an Euclidean space  $E$ . A stratification of  $X$  is an increasing, finite filtration*

$$F_{-1} = \emptyset \subset F_0 \subset F_1 \subset \dots \subset F_m = X$$

satisfying the following properties.

- (a)  $F_k$  is closed in  $X$ ,  $\forall k$ .
- (b) For every  $k = 1, \dots, m$  the set  $X_k = F_k \setminus F_{k-1}$  is a smooth manifold of dimension  $k$  with finitely many connected components called the  $k$ -dimensional strata of the stratification.
- (c) (The frontier condition) For every  $k = 1, \dots, m$  we have

$$\text{cl}(X_k) \setminus X_k \subset F_{k-1}.$$

The stratification is said to satisfy the Whitney condition (a) (resp. (b)) if (d) for every  $0 \leq j < k \leq m$  the pair  $(X_j, X_k)$  satisfies Whitney's regularity condition (a) (resp (b)) along  $X_j$ .

A Whitney stratification is a stratification satisfying the Whitney condition (b) (hence also the condition (a)).

We will specify a stratification of a set  $X$  by indicating the collection  $\mathcal{S}$  of strata of the stratification. The dimension the stratification is the integer

$$\max_{S \in \mathcal{S}} \dim S.$$

If  $S, S' \in \mathcal{S}$  we write  $S < S'$  if  $S \subset \text{cl}(S')$  and  $S \neq S'$ . We say that the stratum  $S'$  covers the stratum  $S$  and we write this  $S < S'$  if  $S < S'$  and  $\dim S' = \dim S + 1$ . We will use the notations

$$X_{>S} := \bigcup_{S' > S} S', \quad X_{\geq S} := \bigcup_{S' \geq S} S' \text{ etc.} \quad \square$$

**Example 4.23.** (a) The simplex

$$\{(x, y) \in \mathbb{R}^2; \ x, y \geq 0, \ x + y \leq 1\}$$

admits a natural Whitney stratification. The strata are: its vertices, the relative interiors of the edges and the interior of the simplex.

(b) Suppose  $(X_i, \mathcal{S}_i)$ ,  $i = 0, 1$  are Whitney stratified subsets of  $\mathbb{R}^{m_i}$ . Then  $X_0 \times X_1$  admits a canonical Whitney stratification with strata  $S_0 \times S_1$ ,  $S_i \in \mathcal{S}_i$ .

A smooth manifold  $X$  with boundary  $\partial X$  admits a canonical Whitney stratification. Its strata are the interior of  $X$  and the connected components of the boundary.

(c) Suppose  $(X, \mathcal{S})$  is a Whitney stratified subset of  $\mathbb{R}^m$  contained in some open ball  $B$ . If  $\Phi : B \rightarrow \mathbb{R}^m$  is a diffeomorphism onto an open subset  $\mathcal{O} \subset \mathbb{R}^m$ , then  $\Phi(X)$  is a Whitney stratified set with strata defined as the images via  $\Phi$  of the strata of  $X$ .

(d) Suppose  $(X_0, \mathcal{S}_0), (X_1, \mathcal{S}_1) \subset \mathbb{R}^m$  are Whitney stratified subsets of  $\mathbb{R}^m$  such that

$$S_0 \pitchfork S_1, \quad \forall S_0 \in \mathcal{S}_0, \ S_1 \in \mathcal{S}_1.$$

Then the collection

$$\{S_0 \cap S_1; \ S_0 \in \mathcal{S}_0, \ S_1 \in \mathcal{S}_1\}$$

defines a Whitney stratification of  $X_0 \cap X_1$ . For a proof we refer to [GWPL, I.1.3].

(e) Suppose  $F : M \rightarrow N$  is a smooth map and  $(X, \mathcal{S}_X)$  is a Whitney stratified subset of  $N$  and  $(Y, \mathcal{S}_Y)$  is a stratified subset of  $M$  such that the restriction of  $F$  to any stratum of  $Y$  is transversal to all the strata of  $X$ . Then the set  $Y \cap F^{-1}(X)$  admits a natural Whitney stratification with strata  $S \cap F^{-1}(S')$ ,  $S \in \mathcal{S}_Y$ ,  $S' \in \mathcal{S}_X$ . To see this consider the stratified subset

$$Z := Y \times X \subset M \times N.$$



Its strata are  $S \times S'$ ,  $S \in \mathcal{S}_Y$ ,  $S' \in \mathcal{S}_X$ . The transversality assumption on  $F$  implies that the graph of  $F$ ,

$$\Gamma_F = \{(p, F(p)); p \in M\} \subset M \times N,$$

intersects transversally the strata of  $Z$ . Thus  $\Gamma_F \cap Z$  is a Whitney stratified subset of  $\Gamma_F$ . The natural projection  $\pi_M : M \times N \rightarrow M$  induces a diffeomorphism  $\Gamma_F \rightarrow M$ . Thus

$$Y \cap F^{-1}(X) = \pi_M(\Gamma_F \cap Z)$$

is a Whitney stratified subset of  $M$  with strata  $S \cap F^{-1}(S')$ ,  $S \in \mathcal{S}_Y$ ,  $S' \in \mathcal{S}_X$ .

(f) Suppose  $(X, \mathcal{S})$  is a Whitney stratified subset of the sphere  $S^{m-1} \subset \mathbb{R}^m$ . Then the *cone on X*

$$C_X = \{z \in \mathbb{R}^m; \exists r \in [0, 1), x \in X \text{ such that } z = rx\}$$

carries a natural Whitney stratification. The strata consists of the origin of  $\mathbb{R}^m$  and the cones on the strata of  $X$  with the origin removed.

(g) This last example may give the reader an idea on the possible complexity of a Whitney stratified space. Consider the solid torus

$$Z = \{(z_0, z_1) \in \mathbb{C}^2; |z_0| \leq 1, |z_1| = 1\}.$$

We denote by  $A$  its axis, i.e. the curve

$$A = \{(z_0, z_1) \in \mathbb{C}^2; z_0 = 0, |z_1| = 1\},$$

and by  $\pi$  the natural projection

$$Z \ni (z_0, z_1) \mapsto (0, z_1) \in A.$$

Along its boundary

$$\partial Z = \{(z_0, z_1) \in \mathbb{C}^2; |z_0| = 1, |z_1| = 1\}$$

we consider the simple closed curve

$$C = \{(z_0, z_1) = (e^{it}, e^{4it}); t \in [0, 2\pi]\}.$$

The restriction of  $\pi$  to  $C$  induces 4 : 1-covering  $C \rightarrow A$ . Consider the singular surface

$$X = \{(re^{it}, e^{i4t}) \in \mathbb{C}^2; r \in [0, 1], t \in [0, 2\pi]\} \subset Z.$$

Note that the axis  $A$  is contained in  $X$ , and  $X \setminus A$  is a smooth submanifold of  $Z$ . Topologically,  $X$  is obtained from four rectangles sharing a common edge  $A$  via the gluing prescription indicated in Figure 4.4. Then the filtration  $A \subset X$  defines a Whitney stratification of  $X$ .  $\square$

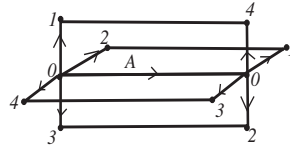

**Fig. 4.4.** A surface with a codimension 1 singularity.

In the traditional smooth context we know that transversality is an open condition. More precisely, if  $X$  is a smooth manifold embedded in some Euclidean space  $E$ , and  $Y$  is a smooth compact submanifold of  $E$  that intersects  $X$  transversally, then a small perturbation of  $Y$  will continue to intersect  $M$  transversally. If  $X$  is an arbitrary stratified space this stability of transversality is no longer true. However, this desirable property holds for stratified spaces satisfying the Whitney condition (a). We state a special case of this fact. The proof is left to the reader as an exercise.

**Proposition 4.24.** *Suppose we are given the following data.*

- A compact smooth manifold  $M$  embedded in some Euclidean space.
- A stratified subset  $X \subset M$  of  $M$  satisfying Whitney's condition (a).
- A smooth compact manifold  $Y$  and a smooth map  $F : [0, 1] \times Y \rightarrow M$ ,  $(t, y) \mapsto F_t(y)$ , such that for any  $t \in [0, 1]$  the map  $Y \ni y \mapsto F_t(y) \in M$  is an embedding.

If  $Y_0 = F_0(Y)$  intersects the strata of  $X$  transversally, then there exists  $\varepsilon > 0$  such that for any  $t \in (-\varepsilon, \varepsilon)$  the manifold  $Y_t = F_t(Y)$  intersects the strata of  $X$  transversally. □

A Whitney stratified space  $X \subset \mathbb{R}^n$  has a rather restricted local structure, in the sense that along a stratum  $S$  of codimension  $c$  the singularities of  $X$  “look the same” in the following sense. If  $s_i$ ,  $i = 0, 1$ , are two points in  $S$  and  $D_{s_i}$  is a small disk of dimension  $c$  centered at  $x_i$  and perpendicular to  $T_{s_i}S$ , then the sets  $X \cap \partial D_{s_0}$  and  $X \cap \partial D_{s_1}$  are homeomorphic. In other words, an observer walking along  $S$  and looking at  $X$  in the directions normal to  $S$  will observe the same shapes at all points of  $S$ . We say that  $X$  is *normally equisingular* along the stratum  $S$ .

In Figure 4.3 we see a violation of equisingularity precisely at the origin, exactly where the (b)-condition is violated. Figure 4.9 also illustrates this principle. The surface in the right-hand side of this figure is equisingular along the axis, while in the left-hand side the equisingularity is violated at this origin. The precise formulation of the above intuitive discussion requires some preparation.

First, we need to defined an appropriate notion of local triviality of a map.

**Definition 4.25.** (a) Suppose  $(X, \mathcal{S})$  is a stratified subset of  $\mathbb{R}^m$ ,  $\mathcal{N}$  is an open neighborhood of  $X$  in  $\mathbb{R}^m$ ,  $M$  is a connected smooth manifold and  $f : \mathcal{N} \rightarrow M$  is a smooth map. We regard  $M$  as a Whitney stratified set with a stratification consisting of a single stratum.

(b) We say that the restriction  $f|_X$  is topologically trivial if there exists a Whitney stratified subset  $(F, \mathcal{F})$  of some Euclidean space and a homeomorphism  $h : F \times M \rightarrow X$  that sends the strata of the product stratification of  $F \times M$  homeomorphically onto the strata of  $(X, \mathcal{S})$  and such that the diagram below is commutative

$$\begin{array}{ccc} F \times M & \xrightarrow{h} & X \\ & \searrow \pi & \swarrow f \\ & & M \end{array}$$

(c) We say that the restriction  $f|_X$  is locally topologically trivial if for any  $x \in M$  there exists an open neighborhood  $U$  such that  $f|_{X \cap f^{-1}(U)}$  is topologically trivial.  $\square$

The next highly nontrivial result describes a criterion of local triviality.

**Theorem 4.26 (Thom’s first isotopy theorem).** Suppose  $(X, \mathcal{S})$  is a Whitney stratified space,  $Y$  is a smooth manifold and  $f : X \rightarrow Y$  is a continuous map satisfying the following conditions.

- The map  $f$  is proper, i.e.,  $f^{-1}(\text{compact}) = \text{compact}$ .
- The restriction of  $f$  to each stratum  $S \in \mathcal{S}$  is a smooth submersion  $f|_S : S \rightarrow Y$ .

Then the map  $f : X \rightarrow Y$  is locally topologically trivial.  $\square$

The proof of this result is very delicate and we refer to [GWPL, Mat] for details. We have the following useful consequence.

**Corollary 4.27.** Suppose we are given the following data.

- (c1) A compact smooth manifold  $M$  embedded in some Euclidean space.
- (c2) A Whitney stratified compact subset  $X \subset M$  of  $M$ .
- (c3) A smooth compact manifold  $Y$  and a smooth map  $F : [0, 1] \times Y \rightarrow M$ ,  $(t, y) \mapsto F_t(y)$ , such that for any  $t \in [0, 1]$  the map  $Y \ni y \mapsto F_t(y) \in M$  is an embedding, and the submanifold  $Y_t = F_t(Y)$  intersects transversally the strata of  $X$ .

Then the stratified spaces  $Y_t \cap X$ ,  $t \in [0, 1]$  have the same topological type, and

$$cl(F([0, 1] \times Y)) = F([0, 1] \times Y).$$

*Proof.* We regard  $[0, 1] \times Y$  as a stratified space obtained as the product of the spaces  $[0, 1]$  and  $Y$  equipped with the natural stratifications. Consider the space

$$Z := F^{-1}(X) \subset [0, 1] \times Y.$$

From Example 4.23(e) we deduce that  $Z$  carries a natural Whitney stratification. The condition (c3) implies that the natural projection

$$Z \subset [0, 1] \times Y \rightarrow [0, 1]$$

is transversal to all the strata of  $Z$ . The desired conclusions now follow from Thom’s first isotopy theorem.  $\square$

Suppose now that  $X \subset \mathbb{R}^m$  is a Whitney stratified subset. Denote by  $\mathcal{S}$  the collection of strata. Assume that for every stratum  $U \in \mathcal{S}$  we are given a tubular neighborhood  $T_U$  of  $U \hookrightarrow \mathbb{R}^m$ . We denote by  $\pi_U$  (resp.  $\rho_U$ ) the projection (resp. the tubular function) associated to  $T_U$ . For any stratum  $V < U$  we distinguish two commutativity relations.

$$\pi_V \circ \pi_U(x) = \pi_V(x), \quad \forall x \in |T_U| \cap |T_V| \cap \pi_U^{-1}(|T_V| \cap U). \quad (C_\pi)$$

$$\rho_V \circ \pi_U(x) = \rho_V(x), \quad \forall x \in |T_U| \cap |T_V| \cap \pi_U^{-1}(|T_V| \cap U). \quad (C_\rho)$$

A *controlled tube system* for the Whitney stratified set  $(X, \mathcal{S})$  is a collection of tubes  $\{T_U\}_{U \in \mathcal{S}}$  satisfying the above commutativity identities.

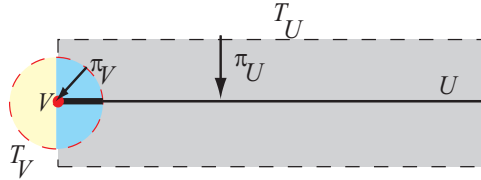

**Fig. 4.5.** *Non-compatible tubular neighborhoods*

**Example 4.28.** In Figure 4.5 the condition  $(C_\pi)$  is satisfied but the condition  $(C_\rho)$  is violated. The tubular neighborhoods in Figure 4.6 are compatible, i.e., both commutativity relations are satisfied.  $\square$

We have the following fundamental and highly non-trivial result whose proof can be found in [GWPL, II.§5] or [Mat].

**Theorem 4.29 (Normal equisingularity).** *Suppose  $(X, \mathcal{S})$  is a Whitney stratified subset  $\mathbb{R}^m$ . Then there exists a controlled tube system  $(T_S)_{S \in \mathcal{S}}$  such that for any stratum  $S$  the induced map*

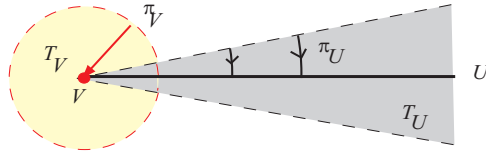

Fig. 4.6. Compatible tubular neighborhoods

$$\pi_S \times \rho_S : X_{>S} \cap T_S \rightarrow \widehat{S}_\epsilon := \{(x, t) \in S \times (0, \infty); t < \epsilon_S(x)^2\}$$

is locally topologically trivial in the sense of Definition 4.25(b). □

The above result has a very rich geometric content that we want to dissect. The typical fiber of the fibration  $\pi_S \times \rho_S : X_{>S} \cap T_S \rightarrow \widehat{S}_\epsilon$  is an important topological invariant of the stratum  $S$  called the *normal link* of  $S$  in  $X$ , and it is denoted by  $\mathcal{L}_S$  or  $\mathcal{L}_S(X)$ . It can be described as a Whitney stratified set as follows. Choose  $x \in S$  and let  $c$  denote the codimension of  $S$ . Next choose a *local transversal* to  $S$  at  $x$ , i.e., a Riemann submanifold  $Z_x$  of dimension  $c$  of the ambient space  $\mathbb{R}^m$  that intersects  $S$  only at  $x$  and such that

$$T_x S + T_x Z_x = T_x \mathbb{R}^m.$$

Next choose a Riemann metric  $g$  on  $Z_x$ . Then  $\mathcal{L}_S$  can be identified with the intersection

$$X_{>S} \cap \{z \in Z_x; \text{dist}_g(z, x) = \epsilon\}$$

for  $\epsilon$  sufficiently small. Thom’s first isotopy lemma shows that the topological type of  $\mathcal{L}_S$  is independent of the choice of the local transversal, the metric  $g$  and  $\epsilon > 0$  small. The induced map

$$\pi_S : T_S \cap X \rightarrow S$$

is also locally topologically trivial. Its typical fiber is the cone on the link  $\mathcal{L}_S$  as defined in Example 4.23(d).

**Example 4.30.** (a) Consider the Whitney stratified set  $X$  in Example 4.23(g). Then the link of the stratum  $A$  is the topological space consisting of four points. The equisingularity along  $A$  is apparent in Figure 4.4.

(b) In Figure 4.7 we have depicted a Whitney stratification of the 2-torus consisting of a single 0-dimensional stratum  $v$ , two 1-dimensional strata  $a, b$ , and a single 2-dimensional stratum  $R$ . The link  $v$  is the circle depicted in the right-hand side of the figure. It carries a natural stratification consisting of four 0-dimensional strata and four 1-dimensional strata. □

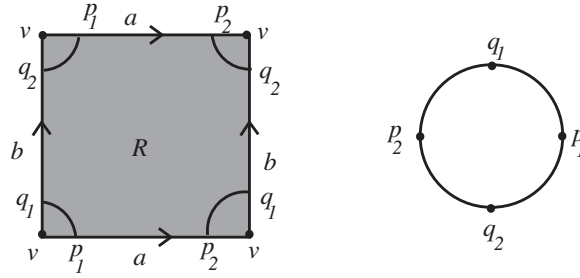

Fig. 4.7. A Whitney stratification of the 2-torus.

Let us record for later use the following useful technical result, [Mat, Cor. 10.4]

**Proposition 4.31.** *Suppose  $(X, \mathcal{S})$  is a compact Whitney stratified subset of  $\mathbb{R}^m$ ,  $S_0 < S_1$  are two strata of the stratification. and  $W$  is a submanifold of  $\mathbb{R}^m$  that intersects  $S_0$ . Then*

$$S_0 \cap W \subset \text{cl}(S_1 \cap W). \quad \square$$

### 4.3 Smale transversality $\iff$ Whitney regularity

Suppose  $M$  is a compact, connected smooth manifold of dimension  $m$ ,  $f$  is a Morse function on  $M$  and  $\xi$  is a gradient like vector field on  $M$ . Denote by  $\Phi^\xi$  the flow generated by  $-\xi$ , by  $W_p^-(\xi)$  (respectively  $W_p^+(\xi)$ ) the unstable (respectively stable) manifold of the critical point  $p$ , and set

$$M_k(\xi) := \bigcup_{p \in \text{Cr}_f, \lambda(p) \leq k} W_p^-(\xi), \quad \mathcal{S}_k^-(\xi) = M_k(\xi) \setminus M_{k-1}(\xi).$$

We say that the flow  $\Phi^\xi$  satisfies the *Morse-Whitney* condition (a) (resp. (b)) if the increasing filtration

$$M_0(\xi) \subset M_1(\xi) \subset \dots \subset M_m(\xi)$$

is a stratification satisfying the Whitney condition (a) (resp. (b)). In the sequel, when no confusion is possible, we will write  $W_p^\pm$  instead of  $W_p^\pm(\xi)$ .

**Theorem 4.32.** *If the Morse flow  $\Phi^\xi$  satisfies the Morse-Whitney condition (a), then it also satisfies the Morse-Smale condition.*

*Proof.* Let  $p, q \in \mathbf{Cr}_f$  such that  $p \neq q$  and  $W_p^- \cap W_q^+ \neq \emptyset$ . Let  $k$  denote the Morse index of  $q$ , and  $\ell$  the Morse index of  $p$  so that  $\ell > k$ . We want to prove that this intersection is transverse. Let  $x \in W_p^- \cap W_q^+$  and set  $x_t := \Phi_t^\xi(x)$ . Observe that

$$T_x W_q^+ \pitchfork T_x W_p^- \iff \exists t \geq 0 : T_{x_t} W_q^+ \pitchfork T_{x_t} W_p^-.$$

We will prove that  $T_{x_t} W_q^+ \pitchfork T_{x_t} W_p^-$  if  $t$  is sufficiently large.

We can find coordinates  $(u^i)$  in a neighborhood  $U$  of  $q$ , such that

$$u^j(q) = 0, \quad \forall j, \quad \xi = \sum_{i=1}^k 2u^i \partial_{u_i} - \sum_{\alpha > k} 2u^\alpha \partial_{u_\alpha}.$$

Denote by  $A$  the diagonal matrix

$$A = \text{Diag}(\underbrace{-2, \dots, -2}_k, \underbrace{2, \dots, 2}_{m-k}).$$

Without any loss of generality, we can assume that the point  $x$  lies in the coordinate neighborhood  $U$ . Denote by  $E$  the Euclidean space with Euclidean coordinates  $(u^i)$ . Then the path  $t \mapsto T_{x_t} W_p^- \in \text{Gr}_\ell(E)$  is given by

$$T_{x_t} W_p^- = e^{tA} T_x W_p^-.$$

We deduce that it has a limit

$$\lim_{t \rightarrow \infty} T_{x_t} W_p^- = T_\infty \in \text{Gr}_\ell(E).$$

Since the pair  $(W_q^-, W_p^-)$  satisfies the Whitney regularity condition (a) along  $W_q^-$ , and  $x_t \rightarrow q$ , as  $t \rightarrow \infty$ , we deduce

$$T_\infty \supset T_q W_q^- \implies T_\infty \pitchfork T_q W_q^+.$$

Thus, for  $t$  sufficiently large  $T_{x_t} W_p^- \pitchfork T_{x_t} W_q^+$ . □

**Theorem 4.33.** *Suppose  $M, f$  and  $\xi$  are as in Theorem 4.32, and the flow  $\Phi^\xi$  satisfies the Morse-Smale condition. Then the flow  $\Phi^\xi$  satisfies the Morse-Whitney condition, i.e., the stratification by unstable manifolds satisfies the Whitney regularity (b).*

*Proof.* We will achieve this in three steps.

- (a) First, we prove that the stratification by unstable manifolds satisfies the frontier condition.
- (b) Next, we show that it satisfies Whitney's condition (a).
- (c) We conclude by proving that it also satisfies the condition (b').

To prove the frontier condition it suffices to show that

$$W_q^- \cap \mathbf{cl}(W_p^-) \neq \emptyset \implies \dim W_q^- < \dim W_p^-.$$

Observe that the set  $W_q^- \cap \mathbf{cl}(W_p^-)$  is flow invariant, and its intersection with any compact subset of  $W_p^-$  is closed. We deduce that  $p \in W_q^- \cap \mathbf{cl}(W_p^-)$ .

Fix a small neighborhood  $U$  of  $p$  in  $W_p^-$ . Then there exists a sequence  $x_n \in \partial U$ , and a sequence  $t_n \in [0, \infty)$ , such that

$$\lim_{n \rightarrow \infty} t_n = \infty, \quad \lim_{n \rightarrow \infty} \Phi_{t_n}^\xi x_n = q.$$

In particular, we deduce that  $f(p) > f(q)$ . For every  $n$  define

$$C_n := \mathbf{cl}(\{\Phi_t^\xi x_n; t \in (-\infty, t_n]\}).$$

Denote by  $\mathbf{Cr}_q^p$  the set of critical points  $p'$  such that  $f(q) < f(p') < f(p)$ . For every  $p' \in \mathbf{Cr}_q^p$  we denote by  $d_n(p')$  the distance from  $p'$  to  $C_n$ . We can find a set  $S \subset \mathbf{Cr}_q^p$  and a subsequence of the sequence  $(C_n)$ , which we continue to denote by  $(C_n)$ , such that

$$\lim_{n \rightarrow \infty} d_n(p') = 0, \quad \forall p' \in S \quad \text{and} \quad \inf_n d_n(p') > 0, \quad \forall p' \in \mathbf{Cr}_q^p \setminus S.$$

Label the points in  $S$  by  $s_1, \dots, s_k$ , so that

$$f(s_1) > \dots > f(s_k).$$

Set  $s_0 = p, s_{k+1} = q$ . The critical points in  $S$  are hyperbolic, and we conclude that there exist trajectories  $\gamma_0, \dots, \gamma_k$  of  $\Phi$ , such that

$$\lim_{t \rightarrow -\infty} \gamma_i(t) = s_i, \quad \lim_{t \rightarrow \infty} \gamma_i(t) = s_{i+1}, \quad \forall i = 0, \dots, k,$$

and

$$\liminf_{n \rightarrow \infty} \text{dist}(C_n, \Gamma_0 \cup \dots \cup \Gamma_k) = 0,$$

where  $\Gamma_i = \mathbf{cl}(\gamma_i(\mathbb{R}))$ , and  $\text{dist}$  denotes the Hausdorff distance. We deduce

$$W_{s_i}^- \cap W_{s_{i+1}}^+ \neq \emptyset, \quad \forall i = 0, \dots, k.$$

Since the flow  $\Phi^\xi$  satisfies the Morse-Smale condition we deduce from the above that

$$\dim W_{s_i}^- > \dim W_{s_{i+1}}^-, \quad \forall i = 0, \dots, k.$$

In particular,  $\dim W_p^- > \dim W_q^-$ .

To prove that the stratification satisfies the regularity condition (a), we will show that for every pair of critical points  $p, q$ , and every  $z \in W_q^- \cap \mathbf{cl}(W_p^-)$ , there exists an open neighborhood  $U$  of  $z \in M$ , and a positive constant  $C$  such that



$$\delta(T_x W_q^-, T_y W_p^-) \leq C \operatorname{dist}(x, y)^2, \quad \forall x \in U \cap W_q^-, \quad \forall y \in U \cap W_p^-. \quad (4.9)$$

Since the map  $x \mapsto \Phi_t(x)$  is smooth for every  $t$ , the set of points  $z \in W_p^- \cap \mathbf{cl}(W_q^-)$  satisfying (4.9) is open in  $W_q^-$  and flow invariant. Since  $q \in \mathbf{cl}(W_p^-) \cap \mathbf{cl}(W_q^-)$  it suffices to prove (b) in the special case  $z = q$ . We will achieve this using an inductive argument.

For every  $0 \leq k \leq m = \dim M$  we denote by  $\mathbf{Cr}_f^k$  the set of index  $k$  critical points of  $f$ . We will prove by decreasing induction over  $k$  the following statement.

$\mathcal{S}(k)$ : For every  $q \in \mathbf{Cr}_f^k$ , and every  $p \in \mathbf{Cr}_f$  such that  $q \in \mathbf{cl}(W_p^-)$  there exists a neighborhood  $U$  of  $q \in M$ , and a constant  $C > 0$  such that (4.9) holds.

The statement is vacuously true when  $k = m$ . We fix  $k$ , we assume that  $\mathcal{S}(k')$  is true for any  $k' > k$ , and we will prove that the statement is true for  $k$  as well. If  $k = 0$  the statement is trivially true because the distance between the trivial subspace and any other subspace of a vector space is always zero. Therefore, we can assume  $k > 0$ .

Fix  $q \in \mathbf{Cr}_f^k$ , and  $p \in \mathbf{Cr}_f^\ell$ ,  $\ell > k$ . Fix a real number  $R > 0$  and coordinates  $(u^i)$  defined in a neighborhood of  $\mathcal{N}$  of  $q$  such that

$$\xi = - \sum_{i \leq k} 2u^i \partial_{u^i} + \sum_{\alpha > k} 2u^\alpha \partial_{u^\alpha},$$

and

$$\{ (u^1(x), \dots, u^m(x)) \in \mathbb{R}^m; \quad x \in \mathcal{N} \} \supset [-R, R]^m.$$

For every  $r \leq R$  we set

$$\mathcal{N}_r := \{ x \in \mathcal{N}; \quad |u^j(x)| \leq r, \quad \forall j = 1, \dots, m \}.$$

For every  $x \in \mathcal{N}_R$  we define its horizontal and vertical components,

$$\mathbf{h}(x) = (u^1(x), \dots, u^k(x)) \in \mathbb{R}^k, \quad \mathbf{v}(x) = (u^{k+1}(x), \dots, u^m(x)) \in \mathbb{R}^{m-k}.$$

Define (see Figure 4.8)

$$\mathcal{S}_q^+(r) := \{ x \in W_q^+ \cap \mathcal{N}_r; \quad |\mathbf{v}(x)| = r \}, \quad Z_q^+(r) = \{ x \in \mathcal{N}_r; \quad |\mathbf{v}(x)| = r \}.$$

The set  $Z_q^+(r)$  is the boundary of a ‘‘tube’’ of radius  $r$  around the unstable manifold  $W_q^-$ .

We denote by  $U$  the horizontal subspace of  $\mathbb{R}^m$  given by  $\{\mathbf{v}(u) = 0\}$ , and by  $U^\perp$  its orthogonal complement. Observe that for every  $x \in W_q^- \cap \mathcal{N}_R$  we have  $T_x W_p^- = U$ . Finally, for  $k' > k$  we denote by  $\mathcal{T}_{k'}(U^\perp) \subset \operatorname{Gr}_{k'}(\mathbb{R}^m)$  the set of  $k'$ -dimensional subspaces of  $\mathbb{R}^m$  which intersect  $U^\perp$  transversally.

From part (a) we deduce that there exists  $r \leq R$

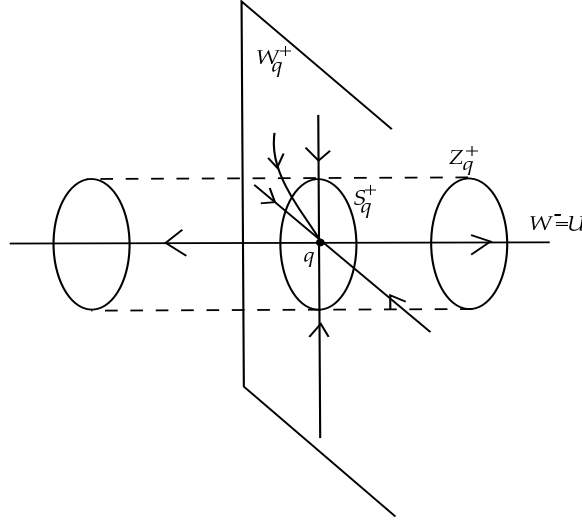

**Fig. 4.8.** The dynamics in a neighborhood of a hyperbolic point.

$$\mathcal{N}_r \cap \mathbf{cl}(W_{q'}^-) = \emptyset, \quad \forall j \leq k, \quad \forall q' \in \mathbf{Cr}_f^j, \quad q' \neq q. \quad (4.10)$$

For every critical point  $p'$  we set

$$C(p', q) := W_{p'}^- \cap W_q^+, \quad C(p', q)_r := C(p', q) \cap \mathbf{S}_q^+(r).$$

Now consider the set

$$X_r(q) := C(p, q)_r \cup \bigcup_{k < \lambda(p') < \ell} C(p', q)_r.$$

For any positive number  $h$  we set

$$\mathcal{G}_{r,h} := \mathbf{cl}(\{T_x W_p^-; x \in Z_q^+(r); |\mathbf{h}(x)| \leq h\}) \subset \mathbf{Gr}_\ell(\mathbb{R}^m). \quad (4.11)$$

**Lemma 4.34.** *There exists a positive  $h \leq r$  such that  $\mathcal{G}_{r,h} \subset \mathcal{T}_\ell(U^\perp)$ .*

*Proof.* We argue by contradiction. Assume that there exist sequences  $h_n \rightarrow 0$  and  $x_n \in \mathcal{N}_r$  such that

$$|\mathbf{v}(x_n)| = r, \quad |\mathbf{h}(x_n)| \leq h_n, \quad \delta(U, T_{x_n} W_p^-) \geq 1 - \frac{1}{n}.$$

By extracting subsequences we can assume that  $x_n \rightarrow x \in \mathbf{S}_q^+(r)$  and  $T_{x_n} W_p^- \rightarrow T_\infty$  so that

$$\delta(U, T_\infty) = 1 \iff T_\infty \text{ does not intersect } U^\perp \text{ transversally.} \quad (4.12)$$

From the frontier condition and (4.10) we deduce  $x \in X_r(q)$ . If  $x \in C(p, q)_r$ , then  $x \in W_p^- \cap S_q^+(r)$ , and we deduce  $T_\infty = T_x W_p^-$ . On the other hand, the Morse-Smale condition shows that  $T_x W_p^-$  intersects transversally  $T_x W_q^+ = U^\perp$  which contradicts (4.12).

Thus  $x \in C(p', q)$  with  $\lambda(p') = k'$ ,  $k < k' < \ell$ . Since we assumed that the statement  $\mathcal{S}(k')$  is true, we deduce  $\delta(T_x W_{p'}^-, T_\infty) = 0$ , i.e.,

$$T_\infty \supset T_x W_{p'}^-.$$

From the Morse-Smale condition we deduce that  $T_x W_{p'}^-$  intersects  $T_x W_q^+ = U^\perp$  transversally, and a fortiori,  $T_\infty$  will intersect  $U^\perp$  transversally. This again contradicts (4.12).  $\square$

Fix  $\hbar \in (0, r]$  such that the compact set

$$\mathcal{G}_{r, \hbar} = \{ T_x W_p^-; x \in W_p^- \cap Z_q^+(r), |\mathbf{h}(x)| \leq \hbar \} \subset \text{Gr}_\ell(\mathbb{R}^m)$$

is a subset of  $\mathcal{J}_\ell(U^\perp)$ . Consider the block

$$\mathcal{B}_{r, \hbar} := \{ x \in \mathcal{N}_r; |\mathbf{v}(x)| \leq r, |\mathbf{h}(x)| \leq \hbar \}.$$

The set  $\mathcal{B}_{r, \hbar}$  is a compact neighborhood of  $q$ . Define

$$\begin{aligned} A_u &: \mathbb{R}^k \rightarrow \mathbb{R}^k, \quad A_u = \text{Diag}(2, \dots, 2), \\ A_s &: \mathbb{R}^{m-k} \rightarrow \mathbb{R}^{m-k}, \quad A_s = \text{Diag}(2, \dots, 2), \\ A &: \mathbb{R}^m \rightarrow \mathbb{R}^m, \quad A = \text{Diag}(A_u, -A_s). \end{aligned}$$

For every  $x \in \mathcal{B}_{r, \hbar} \setminus W_q^-$  we denote by  $I_x$  the connected component of

$$\{ t \leq 0; \Phi_t^\xi x \in \mathcal{B}_{r, \hbar} \}$$

which contains 0. The set  $I_x$  is a closed interval

$$I_x := [-T(x), 0], \quad T(x) \in [0, \infty].$$

If  $x \in \mathcal{B}_{r, \hbar} \setminus W_q^-$  then  $T(x) < \infty$ . We set

$$z(x) := \Phi_{-T(x)}^\xi x, \quad y(x) := \mathbf{v}(z(x)).$$

Then

$$y(x) = e^{T(x)A_s} \mathbf{v}(x), \quad |y(x)| = r.$$

We deduce

$$|\mathbf{v}(x)| = |e^{-T(x)A_s} y(x)| = e^{-2T(x)} |y(x)| = e^{-2T(x)} r.$$

Hence

$$e^{-2T(x)} \leq \frac{1}{r} |\mathbf{v}(x)|. \quad (4.13)$$

Let  $x \in \mathcal{B}_{r,\hbar} \cap W_p^-$ . Then

$$T_x W_p^- = e^{T(x)A} T_{z(x)} W_p^-, \quad T_{z(x)} W_p^- \in \mathcal{G}_{r,\hbar},$$

and we deduce

$$\delta(U, T_x W_p^-) = \delta(U, e^{T(x)A} T_{z(x)} W_p^-), \quad U = T_q W_q^-.$$

Using Corollary 4.10 we deduce that there exists a constant  $C > 0$  such that for every  $V \in \mathcal{G}_{r,\hbar}$ , and every  $t \geq 0$  we have

$$\delta(U, e^{tA} V) \leq C e^{-4t}.$$

Hence

$$\forall x \in \mathcal{B}_{r,\hbar} \cap W_p^- : \delta(U, T_x W_p^-) \leq C e^{-4T(x)},$$

Observing that

$$e^{-4T(x)} \stackrel{(4.13)}{\leq} \frac{1}{r^2} |\mathbf{v}(x)|^2,$$

we conclude that

$$\forall x \in \mathcal{B}_{r,\hbar} \cap W_p^- : \delta(U, T_x W_p^-) \leq C \frac{1}{r^2} |\mathbf{v}(x)|^2 = \frac{C}{r^2} \text{dist}(x, W_q^-)^2.$$

Since for every  $w \in \mathcal{B}_{r,\hbar} \cap W_q^-$  we have  $U = T_w W_q^-$ , the last inequality proves  $\mathcal{S}(k)$ .

Finally, let us prove the regularity condition (b'). Fix a critical point  $q$  of index  $k$  and an critical point  $p$  of index  $\ell > k$ . Fix  $r, \hbar$  small as before. Due to the flow invariance of  $W_q^-$  and  $W_p^-$  it suffices to prove that the condition (b') is satisfied in a neighborhood  $\mathcal{N}_r$  of  $q$ . We identify  $q$  with the origin of  $\mathbb{R}^m$  and  $\mathcal{N}_r$  with an open neighborhood of  $0 \in \mathbb{R}^m$ . The stable manifold of  $q$  can be identified with the subspace  $V = U^\perp$  of  $\mathbb{R}^n$  spanned by the vertical vectors. We will show that if  $x_n$  is a sequence of points on  $W_p^-$  such that

- $x_n \rightarrow x_\infty \in W_p^- \cap \mathcal{N}_r$ ,
- $T_{x_n} W_p^- \rightarrow T_\infty \in \text{Gr}_\ell(\mathbb{R}^m)$ ,
- the line  $L_n$  spanned by  $\mathbf{v}(x_n)$  converges to a line  $L_\infty$ ,

then  $L_\infty \subset T_\infty$ .

Denote by  $t_n$  the unique positive real number such that  $e^{2t_n} |\mathbf{v}(x_n)| = r$ , and denote by  $y_n$  the point

$$y_n := \Phi_{-t_n} x_n = e^{-t_n A} x_n.$$

Observe that the line  $L_n$  spanned by  $\mathbf{v}(x_n)$  coincides with the line spanned by  $\mathbf{v}(y_n)$ . More generally, for any subspace  $S \subset V$  we have  $e^{tA} S = S$ . Hence

$$(V \cap T_{y_n} W_p^-) = e^{t_n A}(V \cap T_{y_n} W_p^-) = V \cap T_{x_n} W_p^-.$$

We will prove that

$$\lim_{n \rightarrow \infty} \delta(L_n, V \cap T_{y_n} W_p^-) = 0. \quad (4.14)$$

This implies the desired conclusion because

$$\delta(L_n, V \cap T_{y_n} W_p^-) = \delta(L_n, V \cap T_{x_n} W_p^-).$$

Invoking Proposition 4.1(b) we conclude

$$\delta(L_n, T_{x_n} W_p^-) \leq \delta(L_n, V \cap T_{x_n} W_p^-) \rightarrow 0 \text{ as } n \rightarrow \infty.$$

We will prove (4.14) by contradiction. Suppose that

$$\limsup_{n \rightarrow \infty} \delta(L_n, V \cap T_{y_n} W_p^-) > 0.$$

We can find a subsequence  $n_j$  such that the following hold.

- (c1)  $\lim_{n_j \rightarrow \infty} \delta(L_{n_j}, V \cap T_{y_{n_j}} W_p^-) > 0$ .
- (c2) The points  $y_{n_j}$  converge to a point  $y' \in V$ ,  $|y'| = r$ .
- (c3) The tangent spaces  $T_{y_{n_j}} W_p^-$  converge to a space  $T' \in \text{Gr}_\ell(\mathbb{R}^m)$ .

Since the line  $L_n$  spanned by  $\mathbf{v}(y_n)$  converges to  $L_\infty$  and  $\mathbf{h}(y_n) \rightarrow 0$  we deduce that  $L_\infty$  coincides with the line spanned by  $y'$ .

The point  $y'$  belongs to the closure of  $W_p^-$  and thus there exists a critical point  $p'$  such that  $y \in W_{p'}^- \subset \mathbf{cl}(W_p^-)$ . Since the pair  $(W_{p'}^-, W_p^-)$  satisfies the Whitney condition (a) we deduce that the limit space  $T'$  contains the tangent space  $T_{y'} W_{p'}^-$ . Since  $y' \in V$  we deduce that the flow line through  $y'$ ,  $t \mapsto e^{-2t} y'$ ,  $t \geq 0$ , contains the line segment  $(0, y']$ . This proves that the line determined by  $y'$  is contained in  $T_{y'} W_{p'}^-$  and, a fortiori, in  $T'$ . Thus  $L_\infty \subset T'$  and thus

$$L_\infty \subset T' \cap V. \quad (4.15)$$

From Lemma 4.34 we deduce that  $T' \pitchfork V$  and  $T_{y_n} W_p^- \pitchfork V$ , for all  $n$  sufficiently large so that  $|\mathbf{h}(y_n)| \leq \hbar$ . These transversality conditions are needed to use Lemma 4.11. From this lemma, (4.15) and Proposition 4.1(b) we deduce

$$\lim_{n_j \rightarrow \infty} \delta(L_\infty, T_{y_{n_j}} W_p^- \cap V) = \lim_{n_j \rightarrow \infty} \delta(L_\infty, T_{y_{n_j}} W_p^-) = 0.$$

Since  $\lim_{n \rightarrow \infty} (L_{n_j}, L_\infty) = 0$  we conclude that

$$\lim_{n \rightarrow \infty} L_n = L_\infty \text{ and } \lim_{n_j \rightarrow \infty} \delta(L_{n_j}, V \cap T_{y_{n_j}} W_p^-) = 0.$$

This contradicts (c1) and concludes the proof of Theorem 4.33.  $\square$

*Remark 4.35.* (a) The main result of [Lau] on the local structure of the closure of an unstable manifold of a Morse-Smale flow is an immediate consequence of Theorem 4.33 coupled with the normal equisingularity theorem (Theorem 4.29).

(b) Theorem 4.33 has a hidden essential assumption that we want discuss. More precisely, we assumed that in the neighborhood of a critical point the flow  $\Phi_t^\xi$  has the form  $\Phi_t = e^{tA}$ , where  $A$  is a symmetric matrix such that all the positive eigenvalues are clustered at  $\lambda = 2$ , while all the negative eigenvalues are clustered at  $\lambda = -2$ . We want to present a simple example which suggests that some clustering assumption on the eigenvalues of the Hessian at a critical point is needed to conclude the Whitney regularity. For a more detailed analysis of this problem we refer to [Ni2, §7].

Suppose we are in a 3-dimensional situation, and near a critical point  $q$  of index 1 we can find coordinates  $(x, y, z)$  such that  $x(q) = y(q) = z(q) = 0$ ,  $f = \frac{1}{2}(-ax^2 + by^2 + cz^2)$ , and the (descending) Morse flow has the description

$$\Phi_t(x, y, z) = (e^{at}x, e^{-bt}y, e^{-ct}z), \quad a > 0, \quad c > b > 0.$$

The infinitesimal generator of this flow is described by the (linear) vector field

$$\xi = ax\partial_x - by\partial_y - cz\partial_z.$$

The stable variety is the plane  $x = 0$ , while the unstable variety is the  $x$ -axis. In this case  $A$  is the diagonal matrix<sup>3</sup>

$$A = \text{Diag}(a, -b, -c)$$

and we say that its spectrum is *clustered* if it satisfies the clustering condition

$$(c - b) \leq a.$$

We set  $g := c - b$ . The *clustering* terminology is meant to suggest that the positive eigenvalues of the Hessian of  $f$  at 0 are contained in an interval of short length  $g$ , more precisely, shorter than the distance from the origin to the negative part of the spectrum of the Hessian.

Consider the arc

$$(-1, 1) \ni s \mapsto \gamma(s) := (s, s, 1).$$

Observe that the arc  $\gamma$  is a straight line segment that intersects transversally the stable variety of  $q$  at the point  $\gamma(0) = (0, 0, 1)$ . Suppose that  $\gamma$  is contained in the unstable variety  $W_p^-$  of a critical point  $p$  of index 2. We deduce that an open neighborhood of  $\gamma(0)$  in  $W_p^-$  can be obtained by flowing the arc  $\gamma$  along the flow  $\Phi$ . More precisely, we look at the open subset of  $W_p^-$  given by the parametrization

<sup>3</sup> The matrix  $-A$  describes the Hessian of the function  $f$ .

$$(-1, 1) \times \mathbb{R} \ni (s, t) \mapsto \Phi_t(\gamma(s)) = (se^{at}, se^{-bt}, e^{-ct}).$$

The left half of Figure 4.9 depicts a portion of this parameterized surface corresponding to  $|s| \leq 0.2$ ,  $t \in [0, 2]$ ,  $a = b = 1$ ,  $c = 8$ , so that the spectral clustering condition is violated. It approaches the  $x$ -axis in a rather dramatic way, and we notice a special behavior at the origin. This is where the condition (b') is violated. The right half of Figure 4.9 describes the same parameterized situation when  $a = 1$ ,  $b = 1$ , and  $c = 1.5$ , so that we have a clustering of eigenvalues in the sense that  $c < a + b$ . The asymptotic twisting near the origin is less pronounced in this case.

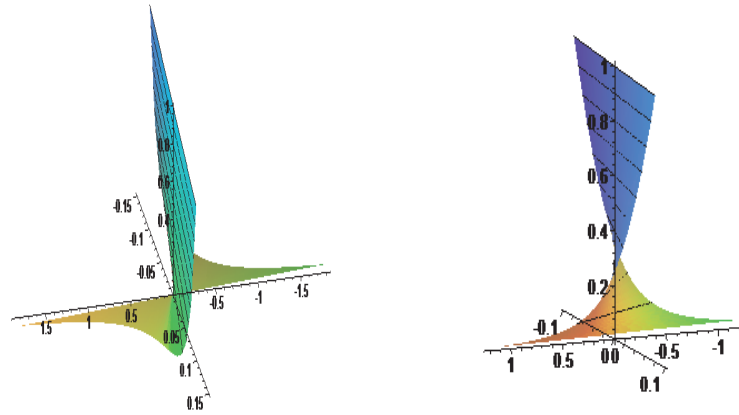

Fig. 4.9. Different behaviors of 2-dimensional unstable manifolds.

Suppose that the clustering condition is violated, i.e.,  $g > a > 0$ . Fix a nonzero real number  $m$ , define  $s_t := me^{-gt}$ , and consider the point

$$p_t := \Phi_t(\gamma(s_t)) = (e^{at}s_t, e^{-bt}s_t, e^{-ct}) = (me^{(a-g)t}, me^{-ct}, e^{-ct}) \in W_p^-.$$

Observe that since  $b < c$  we have  $\lim_{t \rightarrow \infty} s_t = 0$ , and  $a - g < 0$  so that

$$\lim_{t \rightarrow \infty} p_t = q = (0, 0, 0).$$

The tangent space of  $W_p^-$  at the point  $\gamma(s_t)$  is spanned by

$$\gamma'(s_t) = (1, 1, 0) \text{ and } \xi(\gamma(s_t)) = (as_t, -bs_t, -c).$$

Denote by  $L_t$  the tangent plane of  $W_p^-$  at  $p_t$ . It is spanned by

$$\Xi_t := \xi(p_t) = (ae^{at}s_t, -be^{-bt}s_t, -ce^{-ct}) = (mae^{(a-g)t}, -mbe^{-ct}, -ce^{-ct}),$$

and by

$$u_t := D\Phi_t\gamma'(s_t) = (e^{at}, e^{-bt}, 0).$$

Observe that  $L_t$  is also spanned by

$$mae^{-at}u_t = (ma, mae^{-(a+b)t}, 0)$$

and

$$e^{(g-a)t}\Xi_t = (ma, -mbe^{(g-a-c)t}, -ce^{(g-a-c)t}).$$

Noting that  $g - a - c = -(b + a)$  we deduce that  $L_t$  is also spanned by the pair of vectors  $e^{-at}u_t$  and

$$X_t := mae^{-at}u_t - e^{(g-a)t}\Xi_t = (0, e^{-(b+a)t}m(a+b), ce^{-(a+b)t}).$$

Now observe that

$$e^{(a+b)t}X_t = (0, m(a+b), c),$$

which shows that  $L_t$  converges to the 2-plane  $L_\infty$  spanned by

$$(1, 0, 0) = \frac{1}{ma} \lim_{t \rightarrow \infty} e^{-at}u_t = (1, 0, 0) \text{ and } (0, m(a+b), c).$$

On the other hand, if we denote by  $\pi$  the projection onto the  $x$ -axis, the unstable variety of  $q$ , then

$$p_t - \pi(p_t) = (0, me^{-ct}, e^{-ct})$$

and the line  $\ell_t$  spanned by the vector  $p_t - \pi(p_t)$  converges to the line  $\ell_\infty$  spanned by the vector  $(m, 1)$ . The vectors  $(m(a+b), c)$  and  $(m, 1)$  are collinear if and only if  $c = (a+b)$ . We know that this is not the case.

Hence  $\ell_\infty \not\subset L_\infty$ , and this shows that the pair  $(W_q^-, W_p^-)$  does not satisfy Whitney's regularity condition (b') at the point  $q = \lim_t p_t$ .  $\square$

**Example 4.36.** Consider the torus

$$T^2 := \{(x_1, y_1, x_2, y_2) \in \mathbb{R}^4; x_1^2 + y_1^2 = x_2^2 + y_2^2 = 2\}.$$

The function the linear function  $f = y_1 + y_2$  induces a Morse function on this torus. If we equip the torus with the metric induced from  $\mathbb{R}^4$ , then the flow generated by the negative gradient of this function is depicted in Figure 4.10. The stationary point corresponds to the global maximum of  $f$ , while  $v$  corresponds to the local minimum. The stationary points  $a$  and  $b$  are saddle points. The stratification by unstable manifolds coincides with the stratification depicted in Figure 4.7.  $\square$



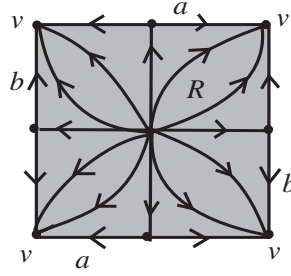

Fig. 4.10. A Morse-Smale flow on the 2-torus.

### 4.4 Spaces of tunnelings of Morse-Smale flows

Suppose that  $M$  is a compact smooth manifold of dimension  $m$ ,  $f : M \rightarrow \mathbb{R}$  is a Morse function and  $\xi : M \rightarrow \mathbb{R}$  is a gradient-like vector field such that the flow  $\Phi^\xi$  generated by  $-\xi$  satisfies the Smale transversality conditions. We then obtain a Whitney stratification  $(M, \mathcal{S}_f)$  of  $M$ , where

$$\mathcal{S}_f := \{W_p^-; p \in \mathbf{Cr}_f\}.$$

We define

$$M_p^- := \bigcup_{W_q^- \leq W_p^-} W_q^-.$$

The order relation between the strata of  $\mathcal{S}_f$  defines an order relation  $\prec$  on  $\mathbf{Cr}_f$  by declaring

$$q \prec p \iff W_q^- < W_p^- \iff W_q^- \subset \mathbf{cl}(W_p^-).$$

The vector field  $-\xi$  is a gradient-like vector field for the function  $-f$  and the flow  $\Phi_t^{-\xi} = \Phi_{-t}^\xi$  also satisfies the Smale condition. We obtain in this fashion a dual stratification

$$\mathcal{S}_{-f} = \{W_p^+; p \in \mathbf{Cr}_f\}.$$

We define similarly

$$M_p^+ := \bigcup_{W_q^+ \leq W_p^+} W_q^+.$$

The Smale condition implies that the strata of  $\mathcal{S}_f$  intersect transversally the strata of  $\mathcal{S}_{-f}$ . For  $q \preceq p$  we set

$$C(p, q) = W_p^- \cap W_q^+.$$

The *connector*  $C(p, q)$  is a  $\Phi^\xi$ -invariant smooth submanifold of  $M$  of dimension  $\lambda(p) - \lambda(q)$ . Note that

$$x \in C(p, q) \iff \lim_{t \rightarrow \infty} \Phi_t^\xi(x) = q, \quad \lim_{t \rightarrow -\infty} \Phi_t^\xi(x) = p,$$

so that  $C(p, q)$  is filled by trajectories of  $\Phi^\xi$  running from  $p$  to  $q$ . We recall that we call such trajectories *tunnelings* from  $p$  to  $q$ . For  $q \prec p$  we set

$$\mathcal{C}(p, q) := M_p^- \cap M_q^+.$$

Since the strata of  $\mathcal{S}_f$  intersect transversally the strata of  $\mathcal{S}_{-f}$  we deduce from Example 4.23(d) that the space  $\mathcal{C}(p, q)$  carries a natural Whitney stratification  $\mathcal{S}_{p,q}$  with strata

$$C(p', q'), \quad q \preceq q' \preceq p' \preceq p.$$

It has a unique top dimensional stratum,  $C(p, q)$ . Proposition 4.31 implies that  $\mathcal{C}(p, q)$  coincides with the closure of  $C(p, q)$ . We have thus proved the following result.

**Corollary 4.37.** *Let  $q \preceq p$ . Then the closure of  $C(p, q)$  is the space  $\mathcal{C}(p, q)$  that carries a natural Whitney stratification with strata*

$$C(p', q'), \quad q \preceq q' \preceq p' \preceq p. \quad \square$$

We want to relate the  $\mathcal{C}(p, q)$  to the space  $\mathcal{M}(p, q)$  of [CJS]. As a set,  $\mathcal{M}(p, q)$  consists of continuous maps

$$\bar{\gamma} : [f(q), f(p)] \rightarrow M$$

satisfying the following conditions.

- The composition  $f \circ \bar{\gamma} : [f(q), f(p)] \rightarrow \mathbb{R}$  is a homeomorphism onto  $[f(p), f(q)]$ .
- If  $r \in [f(q), f(p)]$  is a regular value of  $f$ , then  $\bar{\gamma}$  is differentiable at  $r$  and

$$\left. \frac{d\bar{\gamma}}{ds} \right|_{s=r} = \frac{1}{df(\xi_{\bar{\gamma}(r)})} \xi_{\bar{\gamma}(r)}.$$

For any  $x \in M$  we denote by  $\gamma_x$  the flow line  $\gamma_x(t) = \Phi_t^\xi(x)$ . Set  $p_\pm = \gamma_x(\pm\infty) \in \mathbf{Cr}_f$ . We can associate to  $\gamma_x$  a path  $\bar{\gamma}_x \in \mathcal{M}(p_-, p_+)$ ,

$$\bar{\gamma}_x(s) := \gamma_x(s(t)),$$

where the parametrization

$$\mathbb{R} \ni t \mapsto s(t) \in (f(p_+), f(p_-))$$

is uniquely determined by the equalities

$$\frac{ds}{dt} = \frac{df}{dt}(\gamma_x(-t)), \quad \lim_{t \rightarrow -\infty} s(t) = f(p_+).$$

We see that the image of any map  $\bar{\gamma} \in \mathcal{M}(p, q)$  is a finite union of trajectories  $u_1, \dots, u_k$  of  $\Phi^\xi$  such that

$$\lim_{t \rightarrow -\infty} u_1(t) = p, \quad \lim_{t \rightarrow \infty} u_k(t) = q, \quad \lim_{t \rightarrow \infty} u_i(t) = \lim_{t \rightarrow -\infty} u_{i+1}(t), \quad 1 \leq i \leq k - 1.$$

For this reason we will refer to the paths in  $\mathcal{M}(p, q)$  as *broken tunnelings* from  $p$  to  $q$ .

We topologize  $\mathcal{M}(p, q)$  using the metric of uniform convergence. We have the following result whose proof is left to the reader as an exercise.

**Proposition 4.38.** *The metric space  $\mathcal{M}(p, q)$  is compact.* □

Observe that we have a natural continuous *evaluation map*

$$\mathbf{Ev} : \mathcal{M}(p, q) \times [f(q), f(p)] \rightarrow M, \quad \mathbf{Ev}(\bar{\gamma}, s) = \bar{\gamma}(s).$$

Its image is the space  $\mathcal{C}(p, q)$ . Note that we have a commutative diagram of *surjective maps*

$$\begin{array}{ccc} \mathcal{M}(p, q) \times [f(q), f(p)] & \xrightarrow{\mathbf{Ev}} & \mathcal{C}(p, q) \\ \text{proj} \searrow & & \swarrow f \\ & [f(q), f(p)] & \end{array} \tag{4.16}$$

The space  $\mathcal{M}(p, q)$  contains a large open subset  $M(p, q)$  consisting of paths  $\gamma \in \mathcal{M}(p, q)$  such that the restriction of  $\gamma$  to the open interval  $(f(q), f(p))$  is smooth, the image of  $\gamma$  contains no critical points of  $f$  and

$$\left| \frac{d\gamma(t)}{dt} \right| = \frac{1}{\xi(\gamma(t))} \xi(\dot{\gamma}(t)), \quad \forall f(q) < t < f(p).$$

The evaluation map induces a *homeomorphism*

$$\mathbf{Ev} : M(p, q) \times (f(q), f(p)) \rightarrow C(p, q).$$

Observe that if  $r$  is a regular value of  $f$  situated in the interval  $[f(q), f(p)]$ , then the commutative diagram (4.16) implies that we have a homeomorphism

$$M(p, q) \cong C(p, q)_r := C(p, q) \cap f^{-1}(r).$$

More explicitly, this homeomorphism is described by

$$C(p, q)_r \ni x \mapsto \bar{\gamma}_x \in M(p, q).$$

Since  $r$  is a regular value of  $f$  we deduce that  $C(p, q)_r$  is a smooth manifold of dimension  $\lambda(p) - \lambda(q) - 1$ . We have thus proved the following result.

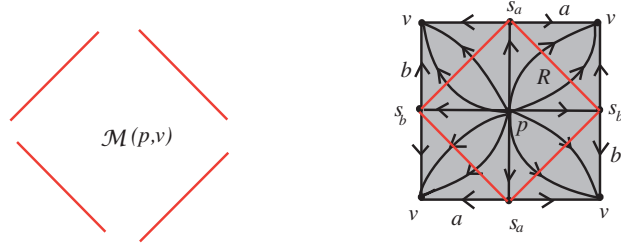

**Fig. 4.11.** A Morse-Smale flow on the 2-torus and the spaces of broken tunnelings.

**Proposition 4.39.** For any critical points  $p, q \in \mathbf{Cr}_f$  such that  $q \prec p$  the space of tunnelings  $M(p, q)$  is homeomorphic to a smooth manifold of dimension  $\lambda(p) - \lambda(q) - 1$ .  $\square$

**Example 4.40.** Consider the Morse-Smale flow on the 2-torus depicted in the right-hand side of Figure 4.11.

It has four critical points: a maximum  $p$ , a minimum  $v$  and two saddle points,  $s_a, s_b$ . The unstable manifold  $W_p^-$  is the interior of the square. The connector  $C(p, v)$  consists of the interiors of the four smaller squares, and its closure is the entire torus. The space  $\mathcal{M}(p, v)$  consists of four disjoint line segments.  $\square$

The behavior displayed in the above example is typical of the general situation. We want to spend the remainder of this section explaining this in greater detail.

For any string of critical points  $p_0 \prec p_1 \prec \dots \prec p_{\nu-1} \prec p_\nu$ , and any  $\varepsilon > 0$  we set

$$\mathcal{M}(p_\nu, \dots, p_1, p_0) := \{ \bar{\gamma} \in \mathcal{M}(p_\nu, p_0); \bar{\gamma}(f(p_k)) = p_k, \quad k = 1, \dots, \nu - 1 \}.$$

Observe that we have an obvious *concatenation* homeomorphism

$$\mathcal{M}(p_\nu, p_{\nu-1}) \times \dots \times \mathcal{M}(p_1, p_0) \ni (\bar{\gamma}_\nu, \dots, \bar{\gamma}_1) \mapsto \bar{\gamma}_\nu * \dots * \bar{\gamma}_1 \in \mathcal{M}(p_\nu, \dots, p_0),$$

where

$$\bar{\gamma}_\nu * \dots * \bar{\gamma}_1(s) = \bar{\gamma}_k(t), \quad \forall 1 \leq k \leq \nu, \quad s \in [f(p_{k-1}), f(p_k)].$$

In particular, we have an inclusion

$$M(p_\nu, p_{\nu-1}) \times \dots \times M(p_1, p_0) \xrightarrow{*} \mathcal{M}(p_\nu, p_0).$$

We denote by  $M(p_\nu, \dots, p_1, p_0)$  its image. It is a topological manifold of dimension

$$\dim M(p_\nu, \dots, p_0) = \lambda(p) - \lambda(q) - \nu.$$

This leads to a stratification of  $\mathcal{M}(p, q)$

$$\mathcal{M}(p, q) = \coprod_{\nu} \coprod_{q=p_0 \prec \dots \prec p_\nu = p} M(p_\nu, \dots, p_0),$$

where the strata are topological manifolds. This stratification enjoys several regularity properties reminiscent of a Whitney stratification. More precisely we want to prove the following key structural result.

**Theorem 4.41. (F1)** *If  $q \prec p$ , then  $M(p, q)$  is dense in  $\mathcal{M}(p, q)$ .*

**(F2)** *If  $q \prec p$ , then  $\mathcal{M}(p, q)$  is homeomorphic to a topological manifold with corners. The “corners” of codimension  $\nu - 1$  are the strata*

$$M(p_\nu, \dots, p_0), \quad p = p_\nu \succ \dots \succ p_0 = q.$$

**Definition 4.42.** *A topological space  $X$  is said to be an  $N$ -dimensional topological manifold with corners if for any point  $x_0 \in X$  there exists an open neighborhood  $\mathcal{N}$  of  $x_0$  in  $X$  and a homeomorphism*

$$\Xi : [0, \infty)^k \times \mathbb{R}^{N-k} \rightarrow \mathcal{N}$$

*that maps the origin to  $x_0$ . The corresponding set  $\Xi(\{0\}^k \times \mathbb{R}^{N-k})$  is said to be a corner of codimension  $k$ .*

*A topological  $N$ -dimensional manifold with corners  $X$  is said to be a smooth manifold with corners if there exists a smooth manifold  $\tilde{X}$  such that the following hold.*

- *The manifold  $X$  is a closed subset of  $\tilde{X}$ .*
- *For any  $x_0 \in X$  there exist an integer  $0 \leq k \leq N$ , a neighborhood  $\tilde{\mathcal{N}}$  of  $x_0$  in  $\tilde{X}$  and a diffeomorphism  $\tilde{\Xi} : \mathbb{R}^N \rightarrow \tilde{\mathcal{N}}$  that maps  $[0, \infty)^k \times \mathbb{R}^{N-k}$  onto  $\tilde{\mathcal{N}} \cap X$ .*

□

*Remark 4.43.* The facts (F1) and (F2) show that we can regard the map  $\mathbf{Ev}$  in (4.16) as a resolution of  $\mathcal{C}(p, q)$ . □

To prove (F1) and (F2) we follow an approach inspired from [KrMr, §18] based on a clever geometric description of the flow  $\Phi^\xi$  near a critical point of  $f$ . A similar strategy is employed in [BFK].

Suppose that  $p$  is a critical point of  $f$ . Set  $\mathbf{E} = \mathbf{E}_p := T_p M$ , so that  $\mathbf{E}$  is an  $m$ -dimensional Euclidean space. Fix coordinates  $(x^i)$  adapted to  $p$  and  $\xi$  defined in a neighborhood  $U_p$  of  $p$ . Via these coordinates we can identify  $U_p$  with an open neighborhood of the origin in  $\mathbf{E}$ . For simplicity we assume that  $U_p$  is an open ball of radius  $2r_p > 0$  centered at the origin. Similarly, we can isometrically identify  $T_p M$  with  $\mathbf{E}$ . We have an orthogonal decomposition

$$\mathbf{E} = T_p W_p^- \oplus T_p W_p^+.$$

For simplicity we set

$$\mathbf{E}^\pm = \mathbf{E}_p^\pm := T_p W_p^\pm.$$

We denote by  $\pi^\pm = \pi_p^\pm$  the orthogonal projection onto  $\mathbf{E}^\pm$ , and we write  $x^\pm := \pi^\pm(x)$ . Note that

$$W_p^\pm \cap U_p = \mathbf{E}_p^\pm \cap U_p.$$

Denote by  $\mathbf{S}^\pm = \mathbf{S}_p^\pm$  the unit sphere in  $\mathbf{E}^\pm$  centered at the origin. For any real number  $\varepsilon \in (0, r_p)$  we set

$$\mathcal{B}_p(\varepsilon) := \{x \in \mathbf{E}; |x^\pm| < \varepsilon\} \subset U_p.$$

The block  $\mathcal{B}_p(\varepsilon)$  has the property that it intersects any flow line of  $\Phi^\xi$  along a connected subset. Indeed, we have

$$x_t = \Phi_t^\xi(x^+, x^-) = (e^{2t}x^+, e^{-2t}x^-),$$

so that  $x_t \in \mathcal{B}_p(\varepsilon)$  if and only if

$$\frac{|x^-|}{\varepsilon} < e^{2t} < \frac{\varepsilon}{|x^+|}.$$

We write

$$\begin{aligned} \mathcal{B}_p(\varepsilon)^* &:= \mathcal{B}_p(\varepsilon) \setminus (\mathbf{E}^- \cup \mathbf{E}^+), \\ \partial_+ \mathcal{B}_p(\varepsilon_-, \varepsilon_+) &:= \{x \in \mathbf{E}; |x^+| = \varepsilon, |x^-| < \varepsilon\}, \\ \partial_- \mathcal{B}_p(\varepsilon_-, \varepsilon_+) &:= \{x \in \mathbf{E}; |x^+| < \varepsilon, |x^-| = \varepsilon\}, \\ \partial_\pm \mathcal{B}_p(\varepsilon)^* &:= \partial_\pm \mathcal{B}_p(\varepsilon) \setminus (\mathbf{E}^- \cup \mathbf{E}^+). \end{aligned}$$

A trajectory that intersects  $\mathcal{B}_p(\varepsilon)$  can have one and only one of the following three behaviors.

- It is contained in the stable manifold of  $p$ .
- It is contained in the unstable manifold of  $p$ .
- It enters  $\mathcal{B}_p(\varepsilon)$  through  $\partial_+ \mathcal{B}_p(\varepsilon)^*$  and exits through  $\partial_- \mathcal{B}_p(\varepsilon)^*$ .

If  $x \in \partial_+ \mathcal{B}_p(\varepsilon)^*$ , then the trajectory of  $\Phi^\xi$  through  $x$  will intersect  $\partial_- \mathcal{B}_p(\varepsilon_-, \varepsilon_+)$  in a point  $\mathcal{J}_p(x)$  so we get a *local tunneling map*

$$\mathcal{J}_p : \partial_+ \mathcal{B}_p(\varepsilon)^* \rightarrow \partial_- \mathcal{B}_p(\varepsilon)^*.$$

If  $x = (x^+, x^-) \in \partial_+ \mathcal{B}_p(\varepsilon)^*$  then

$$|x^+| = \varepsilon, \quad 0 < |x^-| < \varepsilon, \quad \mathcal{J}_p(x) = (e^{-2t}x^+, e^{2t}x^-), \quad t > 0 \quad e^{-2t}|x^-| = \varepsilon.$$

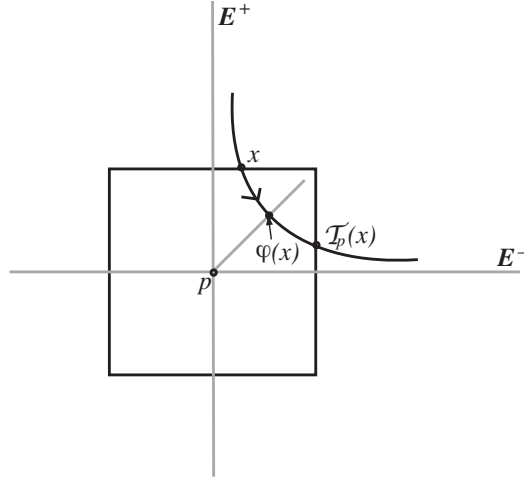

**Fig. 4.12.** The block  $\mathcal{B}_p(\varepsilon)$  and the tunneling map  $\mathcal{J}_p$ .

We deduce  $e^{2t} = \frac{|x^-|}{\varepsilon}$  and

$$\mathcal{J}_p(x) = \left( \frac{|x^-|}{\varepsilon} x^+, \frac{\varepsilon}{|x^-|} x^- \right). \tag{4.17}$$

More precisely if  $p_0, p_1$  are two critical points of  $f$  such that  $p_0 \prec p \prec p_1$ , then the set of tunnelings from  $p_1$  to  $p_0$  that intersect the block  $\mathcal{B}_p(\varepsilon)$  can be identified with the set of solutions of the equation

$$x \in \underbrace{\partial_+ \mathcal{B}_p(\varepsilon)^* \cap W_{p_1}^-}_{=: W_{p_1}^-(p, \varepsilon)^*}, \quad \mathcal{J}_p(x) \in \underbrace{\partial_- \mathcal{B}_p(\varepsilon)^* \cap W_{p_0}^+}_{=: W_{p_0}^+(p, \varepsilon)^*}.$$

Denote by  $M(p_1, p, p_0)_\varepsilon$  the set of tunnelings from  $p_0$  to  $p_1$  that intersect the block  $\mathcal{B}_p(\varepsilon)$ . If we denote by  $\Gamma_p$ , or  $\Gamma_p^\varepsilon$  the graph of  $\mathcal{J}_p$ ,

$$\Gamma_p \subset \partial_+ \mathcal{B}_p(\varepsilon)^* \times \partial_- \mathcal{B}_p(\varepsilon)^*,$$

then we see that we have a homeomorphism

$$\Gamma_p \cap (W_{p_1}^-(p, \varepsilon)^* \times W_{p_0}^+(p, \varepsilon)^*) \ni (x, \mathcal{J}_p(x)) \mapsto \bar{\gamma}_x \in M(p_1, p, p_0)_\varepsilon.$$

To understand the intersection  $\Gamma_p \cap (W_{p_1}^-(p, \varepsilon)^* \times W_{p_0}^+(p, \varepsilon)^*)$  we need a better understanding of the graph  $\Gamma_p$ . Using the equality (4.17) we obtain a diffeomorphism

$$\sigma_\varepsilon : (0, \varepsilon) \times \mathbf{S}^- \times \mathbf{S}^+ \rightarrow \Gamma_p, \quad \sigma_\varepsilon(\rho, \omega^-, \omega^+) = (\rho\omega^-, \varepsilon\omega^+; \varepsilon\omega_-, \rho\omega_+).$$

We denote by  $\bar{\Gamma}_p$  the closure of  $\Gamma_p$  in  $\partial_+ \mathcal{B}_p(\varepsilon) \times \partial_- \mathcal{B}_p(\varepsilon)$ . We notice that  $\sigma_\varepsilon$  extends to a diffeomorphism

$$\bar{\sigma}_\varepsilon : [0, \varepsilon) \times \mathbf{S}^- \times \mathbf{S}^+ \rightarrow \bar{\Gamma}_p.$$

The closure  $\bar{\Gamma}_p$  is a smooth submanifold with boundary in  $\partial_+ \mathcal{B}_p(\varepsilon) \times \partial_- \mathcal{B}_p(\varepsilon)$ . We denote by  $\partial_0 \Gamma_p$  its boundary. Note that we have an equality

$$\partial_0 \Gamma_p = \{0\} \times \mathbf{S}^+ \times \mathbf{S}^- \times \{0\} \cong \mathbf{S}^+ \times \mathbf{S}^-.$$

We like to think of  $\bar{\Gamma}_p$  as the graph of a multi-valued map<sup>4</sup>

$$\partial_+ \mathcal{B}_p(\varepsilon) \dashrightarrow \partial_- \mathcal{B}_p(\varepsilon).$$

We define

$$W_{p_1}^-(p, \varepsilon) := \partial_+ \mathcal{B}_p(\varepsilon) \cap W_{p_1}^-, \quad W_{p_0}^+(p, \varepsilon) := \partial_- \mathcal{B}_p(\varepsilon) \cap W_{p_0}^+.$$

Note that we have a canonical homeomorphism

$$(W_{p_1}^-(p, \varepsilon) \times W_{p_0}^+(p, \varepsilon)) \cap \partial_0 \Gamma_p \cong M(p_1, p) \times M(p, p_0). \quad (4.18)$$

It is useful to have yet another interpretation of the compactification  $\bar{\Gamma}_p$ . Denote by  $\Delta_p(\varepsilon)$  the “diagonal”

$$\Delta_p(\varepsilon) := \{(x_-, x_+) \in \mathcal{B}_p(\varepsilon); |x_-| = |x_+|\}.$$

Equivalently,  $\Delta_p(\varepsilon)$  is the intersection of the block  $\mathcal{B}_p(\varepsilon)$  with the level set  $\{f = f(p)\}$ . Geometrically,  $\Delta_p(\varepsilon)$  is obtained by cone-ing the subset

$$\{(x_-, x_+); |x_-| = |x_+| = \varepsilon\}$$

which is diffeomorphic to the product of the spheres  $\mathbf{S}^- \times \mathbf{S}^+$ .

We set  $\Delta_p(\varepsilon)^* := \Delta_p(\varepsilon) \setminus \{0\}$ . Observe that we have a natural diffeomorphism  $\varphi : \Gamma_p \rightarrow \Delta_p(\varepsilon)^*$  that associates to a point  $(x, \mathcal{T}_p(x))$  on  $\Gamma_p$  the intersection of the flow line  $\gamma_x$  with  $\Delta_p(\varepsilon)$ ; see Figure 4.12. Consider the map

$$\begin{aligned} [0, \varepsilon) \times \mathbf{S}^+ \times \mathbf{S}^- &\xrightarrow{\beta_\varepsilon} \Delta_p(\varepsilon), \\ \beta_\varepsilon(\rho, \omega^+, \omega^-) &= ((\rho\varepsilon)^{\frac{1}{2}}\omega^+, (\rho\varepsilon)^{\frac{1}{2}}\omega^-). \end{aligned} \quad (4.19)$$

The map  $\beta_\varepsilon$  is called the *radial blowup* of  $\Delta_p(\varepsilon)$  at the origin. It induces a diffeomorphism  $(0, \varepsilon) \times \mathbf{S}^+ \times \mathbf{S}^- \rightarrow \Delta_p(\varepsilon)^*$ , and we have a commutative diagram,

$$\begin{array}{ccc} (0, \varepsilon) \times \mathbf{S}^+ \times \mathbf{S}^- & \xrightarrow{\sigma_\varepsilon} & \Gamma_p \\ & \searrow \beta_\varepsilon & \swarrow \varphi \\ & \Delta_p(\varepsilon)^* & \end{array}$$

<sup>4</sup> Algebraic geometers would call this a birational map.



The map  $\varphi$  extends to a map

$$\bar{\varphi} = \beta_\varepsilon \circ \bar{\sigma}_\varepsilon^{-1} : \bar{\Gamma}_p \rightarrow \Delta_p(\varepsilon)$$

topologically equivalent to the radial blowup of  $\Delta_p(\varepsilon)$  at the origin, i.e., we have a commutative diagram

$$\begin{array}{ccc} [0, \varepsilon) \times \mathbf{S}^+ \times \mathbf{S}^- & \xrightarrow{\bar{\sigma}_\varepsilon} & \bar{\Gamma}_p \\ & \searrow \beta_\varepsilon & \swarrow \bar{\varphi} \\ & \Delta_p(\varepsilon) & \end{array}$$

Now observe that

$$\begin{aligned} \mathcal{X}_{p_1, p_0}(p, \varepsilon)^* &:= \sigma_\varepsilon^{-1} \left( \Gamma_p \cap \left( W_{p_1}^-(p, \varepsilon)^* \times W_{p_0}^+(p, \varepsilon)^* \right) \right) \\ &= \varphi^{-1} \left( C(p_1, p_0) \cap \Delta_p(\varepsilon) \right) \\ &= \{ (\rho, \omega^-, \omega^+); (\rho\omega^-, \varepsilon\omega^+) \in W_{p_1}^-, (\varepsilon\omega^-, \rho\omega^+) \in W_{p_0}^+, \rho > 0 \}. \end{aligned}$$

Since  $C(p_1, p_0)$  intersects  $\Delta_p(\varepsilon)$  transversally and  $\delta$  is a diffeomorphism we deduce that  $\mathcal{X}_{p_1, p_0}(p, \varepsilon)^*$  is a smooth submanifold in  $(0, \varepsilon) \times \mathbf{S}^- \times \mathbf{S}^+$ .

Let us observe that the map

$$\bar{\sigma}_\varepsilon : [0, \varepsilon) \times \mathbf{S}^- \times \mathbf{S}^+ \rightarrow \partial_+ \mathcal{B}_p(\varepsilon) \times \partial_- \mathcal{B}_p(\varepsilon)$$

is proper, so its image,  $\bar{\Gamma}_p$ , is a proper submanifold with boundary of  $\partial_+ \mathcal{B}_p(\varepsilon) \times \partial_- \mathcal{B}_p(\varepsilon)$ .

**Lemma 4.44.** *There exists  $\varepsilon_0 = \varepsilon_0(\xi, p) > 0$  such that for any  $\varepsilon \in (0, \varepsilon_0)$  the following hold.*

- (a) *The manifold  $\mathcal{W}_{p_1, p_0} := W_{p_1}^- \times W_{p_0}^+$  intersects  $\partial_+ \mathcal{B}_p(\varepsilon) \times \partial_- \mathcal{B}_p(\varepsilon)$  transversally in  $M \times M$ .*
- (b) *The map*

$$\bar{\sigma}_\varepsilon : [0, \varepsilon) \times \mathbf{S}^- \times \mathbf{S}^+ \rightarrow \partial_+ \mathcal{B}_p(\varepsilon) \times \partial_- \mathcal{B}_p(\varepsilon)$$

*is transversal to the submanifold*

$$\mathcal{W}_{p_1, p_0}(p, \varepsilon) := \mathcal{W}_{p_1, p_0}(p) \cap \left( \partial_+ \mathcal{B}_p(\varepsilon) \times \partial_- \mathcal{B}_p(\varepsilon) \right).$$

*In particular, this shows that*

$$\mathcal{X}_{p_1, p_0}(p, \varepsilon) = \sigma_\varepsilon^{-1} \left( \bar{\Gamma}_p \cap \mathcal{W}_{p_1, p_0}(p, \varepsilon) \right)$$

*is a smooth submanifold with boundary. The boundary is the hypersurface described by the equation  $\rho = 0$ .*

*Proof.* The condition (a) is immediate since for  $\varepsilon > 0$  sufficiently small the vector field  $\xi$  is transversal to  $\partial_{\pm}\mathcal{B}_p(\varepsilon)$ . To prove the transversality conditions (b) we first observe that the map

$$\sigma_{\varepsilon} : (0, \varepsilon) \times \mathbf{S}^{-} \times \mathbf{S}^{+} \rightarrow \partial_{+}\mathcal{B}_p(\varepsilon) \times \partial_{-}\mathcal{B}_p(\varepsilon)$$

is transversal to the submanifold  $\mathcal{W}_{p_1, p_0}(p, \varepsilon)$ . To reach desired conclusions it then suffices to show that the restriction of  $\sigma_{\varepsilon}$  to the boundary  $\{0\} \times \mathbf{S}^{-} \times \mathbf{S}^{+}$  is transversal to  $\mathcal{W}_{p_1, p_0}(p, \varepsilon)$ . The key observation is that the restriction of  $\sigma_{\varepsilon}$  to  $\{0\} \times \mathbf{S}^{-} \times \mathbf{S}^{+}$  coincides with the inclusion

$$\mathbf{S}^{+} \times \mathbf{S}^{-} \hookrightarrow \partial_{+}\mathcal{B}_p(\varepsilon) \times \partial_{-}\mathcal{B}_p(\varepsilon).$$

The Smale transversality condition implies that this product of spheres is transversal to  $\mathcal{W}_{p_1, p_0}(p, \varepsilon)$ .  $\square$

The stability of transversality implies that for any  $\varepsilon < \varepsilon_0(\xi, p)$  there exists  $\delta = \delta(\varepsilon) \in (0, \varepsilon]$  such that the coordinate  $\rho$  on  $[0, \varepsilon) \times \mathbf{S}^{-} \times \mathbf{S}^{+}$  defines a submersion

$$\rho : \mathcal{X}_{p_1, p_0}(p, \varepsilon) \cap \{\rho < \delta\} \rightarrow [0, \delta)$$

The fiber over  $\rho = 0$  is the subset

$$\mathcal{F}_{p_0, p_1}(p)^* := (\mathbf{S}^{+} \cap W_{p_1}^{-}) \times (\mathbf{S}^{-} \cap W_{p_0}^{+}).$$

Note that  $\mathcal{F}_{p_0, p_1}(p)^*$  is homeomorphic with the product  $M(p_1, p) \times M(p, p_0)$ , and  $\mathcal{X}_{p_0, p_1}(p)^*$  is an open subset in  $\mathcal{X}_{p_0, p_1}(p)$ . A point in  $\mathcal{X}_{p_0, p_1}(p, \varepsilon)^* \cap \{\rho = r\}$  corresponds to a tunneling  $\bar{\gamma}$  from  $p_1$  to  $p_0$  that intersects the diagonal  $\Delta_p(\varepsilon)$  at a distance  $(2r\varepsilon)^{1/2}$  from the origin. If we set  $c = f(p)$  then we can write

$$\rho = \rho(\bar{\gamma}) = \frac{1}{2\varepsilon} \text{dist}(p, \bar{\gamma}(c))^2 \tag{4.20}$$

We deduce that for any  $\omega_0 \in \mathcal{F}_{p_0, p_1}(p)^*$  there exist an open neighborhood  $\mathcal{N}$  of  $\omega_0$  in  $\mathcal{F}_{p_0, p_1}(p)^*$ , a positive number  $\delta_1 < \delta$  and a homeomorphism

$$\Xi_{\varepsilon} = \Xi_{\varepsilon, p} : \mathcal{N} \times [0, \delta_1) \rightarrow \mathcal{X}_{p_1, p_0}(p, \varepsilon, \delta_1), \tag{4.21}$$

onto an open neighborhood  $\widehat{\mathcal{N}}$  of  $\omega_0$  in  $\mathcal{X}_{p_1, p_0}(p, \varepsilon, \delta_1)$  such that the diagram below is commutative

$$\begin{array}{ccc} \mathcal{N} \times [0, \delta_1) & \xrightarrow{\Xi_{\varepsilon}} & \widehat{\mathcal{N}} \\ \text{proj} \searrow & & \swarrow \rho \\ & [0, \delta_1) & \end{array}$$

This homeomorphism associates to a point  $\omega \in \mathcal{N}$  and a real number  $r \in (0, \delta_1)$  a point  $\Xi_{\varepsilon}(\omega, r)$  in  $\mathcal{X}_{p_0, p_1}(p, \varepsilon)^* \cap \{\rho = r\}$ . The point  $\omega$  can be identified with a broken trajectory

$$(\bar{\gamma}_1, \bar{\gamma}_0) \in M(p_1, p) \times M(p, p_0),$$

and the point  $\Xi_\varepsilon(\omega, r)$  can be identified with a tunneling  $\bar{\gamma} \in M(p_1, p_0)$ . We like to think of  $\bar{\gamma}$  as an *approximate concatenation* of  $\bar{\gamma}_0$  and  $\bar{\gamma}_1$  that intersects  $\Delta_p(\varepsilon)$  at a distance  $(2r\varepsilon)^{1/2}$  from the origin. For this reason we set

$$\bar{\gamma}_1 \#_{r, \varepsilon, \omega_0} \bar{\gamma}_0 := \Xi_\varepsilon(\bar{\gamma}_1, \bar{\gamma}_0, r).$$

Putting together all of the above we obtain the following result.

**Theorem 4.45.** *Fix  $\varepsilon < \varepsilon_0(\xi)$ , and a broken trajectory*

$$\omega_0 = \bar{\gamma}_1^0 \# \bar{\gamma}_0^0 \in M(p_1, p) \times M(p, p_0).$$

*Then there exists an open neighborhood  $\mathcal{N}$  of  $\omega_0$  in  $M(p_1, p) \times M(p, p_0)$  and  $\delta_1 = \delta_1(\varepsilon) \in (0, \varepsilon)$  such that the following hold.*

1. *If  $\bar{\gamma}_1 \# \bar{\gamma}_0 \in \mathcal{N}$ , then as  $r \searrow 0$ ,  $r < \delta_1$ , the trajectory*

$$\bar{\gamma}_1 \#_{r, \varepsilon, \omega_0} \bar{\gamma}_0 \in \mathcal{M}(p_1, p_0)$$

*converges in  $\mathcal{M}(p_1, p_0)$  to the concatenation  $\bar{\gamma}_1 \# \bar{\gamma}_0 \in \mathcal{M}(p_1, p, p)$ . In particular,  $M(p_1, p, p_0)$  is contained in the closure of  $M(p_1, p_0)$  in  $\mathcal{M}(p_1, p_0)$ .*

2. *The map*

$$\mathcal{N} \times [0, \delta_1) \rightarrow \mathcal{M}(p_1, p_0), \quad (\bar{\gamma}_1, \bar{\gamma}_0, r) \mapsto \bar{\gamma}_1 \#_{r, \varepsilon, \omega_0} \bar{\gamma}_0,$$

*is a homeomorphism onto an open neighborhood  $\widehat{\mathcal{N}}$  of  $\omega_0$  in  $\mathcal{M}(p_1, p_0)$ .*

□

Applying the above theorem inductively we deduce the claim (F1) in Theorem 4.41.

**Corollary 4.46.** *For any critical points  $p \succ q$  of  $f$  the set  $M(p, q)$  is dense in  $\mathcal{M}(p, q)$ .* □

Theorem 4.45 implies immediately the following result.

**Corollary 4.47.** *Suppose  $p \succ p'$  are critical points of  $f$  such that  $\lambda(p) - \lambda(p') = 2$ . Then  $\mathcal{M}(p, p')$  is homeomorphic to a one-dimensional manifold with boundary. Moreover,*

$$\partial \mathcal{M}(p, p') = \bigcup_{q \in \mathbf{Cr}_f, \lambda(p) - \lambda(q) = 1} M(p, q, p'). \quad \square$$

*Remark 4.48.* In Corollary 4.50 of the next section we will give a more direct proof of this result based on the theory of Whitney stratifications. This will provide additional geometric intuition behind the structure of  $\mathcal{M}(p, p')$ .  $\square$

To proceed further we need to introduce additional terminology. For any critical points  $p, q \in \mathbf{Cr}_f$  we set

$$\mathbf{Cr}_f(p, q) := \{p' \in \mathbf{Cr}_f; q \preceq p' \preceq p\}$$

Note that  $\mathbf{Cr}_f(p, q)$  is nonempty if and only if  $q \preceq p$ . A *chain* in  $\mathbf{Cr}_f(p, q)$  is a sequence of critical points  $p_0, \dots, p_\nu \in \mathbf{Cr}_f$  such that

$$p_0 \prec p_1 \prec \dots \prec p_\nu.$$

The integer  $\nu$  is called the *length* of the chain. A *maximal* chain  $\mathbf{Cr}_f(p, q)$  is a chain  $\mathbf{Cr}_f(p, q)$  of maximal length. Note that if  $p_0, \dots, p_\nu$  is a maximal chain in  $\mathbf{Cr}_f(p, q)$  then  $q = p_0$  and  $p = p_\nu$ .

Fix a chain  $p_0, \dots, p_\nu$  in  $\mathbf{Cr}_f(p, q)$  such that  $p_\nu = p$  and  $p_0 = q$ . Fix  $\varepsilon > 0$  sufficiently small. Define

$$\mathcal{M}(p_\nu, \dots, p_1, p_0)_\varepsilon := \{\bar{\gamma} \in \mathcal{M}(p_\nu, p_0); \bar{\gamma}(f(p_k)) \in \mathcal{B}_{p_k}(\varepsilon), 1 \leq k \leq \nu - 1\}.$$

Note that  $\mathcal{M}(p_\nu, \dots, p_1, p_0)_\varepsilon$  is a neighborhood of  $M(p_\nu, \dots, p_0)$  in  $\mathcal{M}(p_\nu, p_0)$ . To ease the notational burden we set

$$\partial_\pm^i(\varepsilon) := \partial_\pm \mathcal{B}_{p_i}(\varepsilon),$$

and we define

$$\Gamma_{p_i, p_{i-1}}^\varepsilon = \Gamma_{p_i, p_{i-1}}^\varepsilon := \{(x, y) \in \partial_-^i(\varepsilon) \times \partial_+^{i-1}(\varepsilon); \exists t > 0 : y = \Phi_t^\varepsilon x\}.$$

The set  $\Gamma_{p_i, p_{i-1}}^\varepsilon$  is the graph of a diffeomorphism  $\mathcal{T}_{p_{i-1}, p_i}^\varepsilon$  from an open subset  $\mathcal{O}_i^- \subset \partial_-^i(\varepsilon)$  onto an open subset  $\mathcal{O}_{i-1}^+ \subset \partial_+^{i-1}(\varepsilon)$ . Note that if  $\varepsilon < \varepsilon'$ , then  $\Gamma_{p_i, p_{i-1}}^\varepsilon \subset \Gamma_{p_i, p_{i-1}}^{\varepsilon'}$ . We denote by  $\mathcal{D}_{i, \varepsilon}^\pm$  the diagonal in  $\partial_\pm^i(\varepsilon) \times \partial_\pm^i(\varepsilon)$  and we set

$$\mathcal{G}_{p_\nu, \dots, p_0}^\varepsilon := \Gamma_{p_{\nu-1}}^\varepsilon \times \Gamma_{p_{\nu-1}, p_{\nu-2}}^\varepsilon \times \Gamma_{p_{\nu-2}}^\varepsilon \times \dots \times \Gamma_{p_2, p_1}^\varepsilon \times \Gamma_{p_1}^\varepsilon,$$

where  $\Gamma_{p_i}^\varepsilon$  denote the graphs of the local tunneling maps  $\mathcal{T}_{p_i} : \partial_+^i(\varepsilon) \rightarrow \partial_-^i(\varepsilon)$ . The set  $\mathcal{G}_{p_\nu, \dots, p_0}^\varepsilon$  is a submanifold of

$$\begin{aligned} \mathcal{Y}^\varepsilon &:= \partial_+^{\nu-1}(\varepsilon) \times (\partial_-^{\nu-1}(\varepsilon) \times \partial_-^{\nu-1}(\varepsilon)) \times \\ &\times \left( \prod_{j=2}^{\nu-2} (\partial_-^j(\varepsilon) \times \partial_-^j(\varepsilon)) \times (\partial_+^j(\varepsilon) \times \partial_+^j(\varepsilon)) \right) \times (\partial_+^1(\varepsilon) \times \partial_+^1(\varepsilon)) \times \partial_-^1(\varepsilon). \end{aligned}$$

Consider the submanifold  $\mathcal{Z}^\varepsilon \subset \mathcal{Y}^\varepsilon$  given by

$$\mathcal{Z}^\varepsilon := (W_{p_\nu}^- \cap \partial_+^{\nu-1}(\varepsilon)) \times \mathcal{D}_{\nu-1, \varepsilon}^- \times$$

$$\times \left( \prod_{j=2}^{\nu-2} \mathfrak{D}_{j,\varepsilon}^- \times \mathfrak{D}_{j,\varepsilon}^+ \right) \times \mathfrak{D}_{1,\varepsilon}^+ \times (\partial_-^1(\varepsilon) \cap W_{p_0}^+).$$

Note that  $\mathcal{G}_{p_\nu, \dots, p_0}^\varepsilon \cap \mathcal{Z}^\varepsilon$  can be identified with the collection of strings of points in  $M$  of the form

$$x_{\nu-1}^+, x_{\nu-1}^-, \dots, x_1^+, x_1^-$$

subject to the constraints

- $x_{\nu-1} \in W_{p_\nu}^- \cap \partial_+^{\nu-1}(\varepsilon)$ .
- $x_1^- \in \partial_-^1(\varepsilon) \cap W_{p_0}^+$ .
- $x_{i-1}^+ = \mathcal{T}_{p_{i-1}, p_i}(x_i^-)$ ,  $x_j^- = \mathcal{T}_{p_j}(x_i^+)$ .

Thus,  $\mathcal{G}_{p_\nu, \dots, p_0}^\varepsilon \cap \mathcal{Z}^\varepsilon$  can be identified with  $M(p_\nu, \dots, p_0)$ . If  $\varepsilon > 0$  is sufficiently small, then the above description coupled with the Smale condition imply that  $\mathcal{G}_{p_\nu, \dots, p_0}^\varepsilon$  intersects  $\mathcal{Z}^\varepsilon$  transversally inside  $\mathcal{Y}^\varepsilon$ . Let us define

$$\overline{\mathcal{G}}_{p_\nu, \dots, p_0}^\varepsilon := \overline{I}_{p_{\nu-1}}^\varepsilon \times I_{p_{\nu-1}, p_{\nu-2}}^\varepsilon \times \overline{I}_{p_{\nu-2}}^\varepsilon \times \dots \times I_{p_2, p_1}^\varepsilon \times \overline{I}_{p_1}^\varepsilon.$$

The intersection of  $\mathcal{Z}^\varepsilon$  with  $\overline{\mathcal{G}}_{p_\nu, \dots, p_0}^\varepsilon$  consists of strings of points in  $M$

$$\mathbf{x} = (x_{\nu-1}^+, x_{\nu-1}^-, \dots, x_1^+, x_1^-)$$

subject to the constraints

- (C1)  $x_i^\pm \in W_{p_i}^\pm \cap \partial_\pm^i(\varepsilon)$ ,  $i = 1, \dots, \nu - 1$ .
- (C2)  $x_{\nu-1}^+ \in W_{p_\nu}^- \cap \partial_+^{\nu-1}(\varepsilon)$ .
- (C3)  $x_1^- \in \partial_-^1(\varepsilon) \cap W_{p_0}^+$ .
- (C4)  $x_{i-1}^+ = \mathcal{T}_{p_{i-1}, p_i}(x_i^-)$ ,  $(x_j^+, x_j^-) \in \overline{I}_{p_j}$

Using the Smale condition we conclude that the above intersection is transverse. Note that there exists a natural bijection between strings  $\mathbf{x}$  satisfying the constraints (C1-C4) and the set  $\widehat{\mathcal{N}}(p_\nu, \dots, p_0)_\varepsilon$  consisting of broken trajectories  $\tilde{\gamma} \in \mathcal{M}(p_\nu, \dots, p_0)_\varepsilon$  that contain no critical point  $p \in \mathbf{Cr}_f \setminus \{p_0, \dots, p_\nu\}$ . We denote by  $\mathbf{x} \mapsto \tilde{\gamma}_\mathbf{x}$  this correspondence. The set  $\widehat{\mathcal{N}}(p_\nu, \dots, p_0)_\varepsilon$  is an open neighborhood of  $M(p_\nu, \dots, p_0)$  in  $\mathcal{M}(p_\nu, p_0)$ , and the map  $\mathbf{x} \mapsto \tilde{\gamma}_\mathbf{x}$  defines a homeomorphism

$$\overline{\mathcal{G}}_{p_\nu, \dots, p_0}^\varepsilon \cap \mathcal{Z}^\varepsilon \rightarrow \widehat{\mathcal{N}}(p_\nu, \dots, p_0)_\varepsilon.$$

Each of the factors  $\overline{I}_{p_i}^\varepsilon$  is a smooth manifold with boundary so that  $\overline{\mathcal{G}}_{p_\nu, \dots, p_0}^\varepsilon$  carries a natural structure of smooth manifold with corners. Each of the factors  $\overline{I}_{p_i}^\varepsilon$  is a subset of  $[0, \varepsilon) \times \mathbf{S}_{p_i}^- \times \mathbf{S}_{p_i}^+$  and thus we have a natural smooth map

$$\rho_i : \overline{I}_{p_i}^\varepsilon \rightarrow [0, \varepsilon).$$

These induce a map

$$\boldsymbol{\rho} = (\rho_1, \dots, \rho_{\nu-1}) : \overline{\mathcal{G}}_{p_\nu, \dots, p_0}^\varepsilon \rightarrow [0, \varepsilon)^{\nu-1} \subset \mathbb{R}^{\nu-1}.$$

Arguing exactly as in the proof of Lemma 4.44 we deduce that the point  $0 \in [0, \varepsilon)^{\nu-1}$  is a regular value of the restriction of  $\rho$  to  $\overline{\mathcal{G}}_{p_\nu, \dots, p_0}^\varepsilon \cap \mathcal{Z}^\varepsilon$ . The implicit function theorem implies that  $\overline{\mathcal{G}}_{p_\nu, \dots, p_0}^\varepsilon \cap \mathcal{Z}^\varepsilon$  is a smooth manifold with corners. This proves the claim (F2) in Theorem 4.41.

### 4.5 The Morse-Floer complex revisited

In the conclusion of this chapter we want to have another look at the Morse-Floer complex.

Suppose that  $M$  is a smooth, compact, connected  $m$ -dimensional manifold and  $(f, \xi)$  is a self-indexing Morse-Smale pair on  $M$ . Denote by  $\Phi_t$  the flow generated by  $-\xi$ .

For every critical point  $p$  of  $f$  we denote by  $W_p^-$  the unstable manifold of  $\Phi$  at  $p$ , by  $W_p^+$  the stable manifold at  $p$  and we fix an orientation  $\mathbf{or}_p^-$  of  $W_p^-$ . Concretely, the orientation  $\mathbf{or}_p^-$  is specified by a choice of a basis of the subspace of  $T_p M$  spanned by the eigenvectors of the Hessian  $H_{f,p}$  corresponding to negative eigenvalues. The orientation  $\omega_p$  defines a *co-orientation* of  $W_p^+ \hookrightarrow M$ , i.e., an orientation of the normal bundle of  $W_p^+ \hookrightarrow M$ .

If  $p, q \in \mathbf{Cr}_f$  are such that

$$\lambda(p) - \lambda(q) = 1,$$

then the connector  $C(p, q) = W_p^- \cap W_q^+$  consists of finitely many tunnelings.

As explained in Remark 2.40(a), the normal bundle of  $C(p, q)$  in  $W_p^-$  can be identified with the restriction to  $C(p, q)$  of the normal bundle of  $W_q^+ \hookrightarrow M$ , i.e., we have a short exact sequence of vector bundles

$$0 \rightarrow TC(p, q) \rightarrow (TW_p^-)|_{C(p,q)} \rightarrow (TW_q^+ M)|_{C(p,q)} \rightarrow 0.$$

Thus the submanifold  $C(p, q) \subset W_p^-$  has a co-orientation induced from the co-orientation of  $W_q^+ \hookrightarrow M$ . This determines an orientation of  $C(p, q)$  defined via the rule

$$\mathbf{or}(TW_p^-)|_{C(p,q)} = \mathbf{or}(TW_q^+ M)|_{C(p,q)} \wedge \mathbf{or} TC(p, q). \tag{4.22}$$

For each flow line  $\gamma$  contained in  $C(p, q)$  we define  $\epsilon(\gamma) = 1$  if the orientation of  $\gamma$  given by the flow coincides with the orientation of  $\gamma$  given by (4.22) and we set  $\epsilon(\gamma) = -1$  otherwise. We can view  $\epsilon$  as a map

$$\epsilon = \epsilon_{p,q} : M(p, q) \rightarrow \{\pm 1\}.$$

We set

$$\langle p|q \rangle := \sum_{\bar{\gamma} \in M(p,q)} \epsilon(\bar{\gamma}).$$

Denote by  $C_k(f)$  the free Abelian group generated by the set  $\mathbf{Cr}_{f,k}$  of critical points of  $f$  of index  $k$ . Each critical point  $p \in \mathbf{Cr}_{f,k}$  determines an element of  $C_k(f)$  that we denote by  $\langle p \rangle$ , and the collection  $(\langle p \rangle)_{p \in \mathbf{Cr}_{f,k}}$  is an integral basis of  $C_k(f)$ . Now define

$$\partial : C_k(f) \rightarrow C_{k-1}(f), \quad \partial \langle p \rangle = \sum_{q \in \mathbf{Cr}_{f,k-1}} \langle p|q \rangle \langle q \rangle, \quad \forall p \in \mathbf{Cr}_{f,k}.$$

In Section 2.5 we gave an indirect proof of the equality  $\partial^2 = 0$ . Below we will present a purely dynamic proof of this fact.

**Theorem 4.49.** *The operator*

$$\partial : \bigoplus_{k=0}^m C_k(f) \rightarrow \bigoplus_{j=0}^m C_j(f)$$

is a boundary operator, i.e.,  $\partial^2 = 0$ . The resulting chain complex  $(C_\bullet(f), \partial)$  is isomorphic to the Morse-Floer complex discussed in Section 2.5.

*Proof.* The theorem is equivalent with the identity

$$\sum_{\substack{p' \prec q \prec p \\ \gamma \in M(p,q), \tilde{\gamma}' \in M(q,p')}} \epsilon(\tilde{\gamma}') \epsilon(\tilde{\gamma}) = 0, \tag{4.23}$$

for any critical points  $p \succ p'$  such that  $\lambda(p) - \lambda(p') = 2$ . We begin by giving an alternate description of the signs  $\epsilon(\tilde{\gamma})$  using the fact that the collection of unstable manifolds is a Whitney stratification of  $M$ .

Fix a controlled tube system for this stratification satisfying the local triviality conditions in Theorem 4.29. For any  $p \in \mathbf{Cr}_f$  we denote by  $\mathcal{J}_p$  the tube around  $W_p^-$ , by  $\pi_p^-$  the projection  $\pi_p^- : \mathcal{J}_p \rightarrow W_p^-$ , by  $\varepsilon_p : W_p^- \rightarrow (0, \infty)$  the width function of  $\mathcal{J}_p$  and by  $\rho_p$  the radial function on  $\mathcal{J}_p$ . With these notations, the fiber of  $\pi_p^-$  over  $x \in W_p^-$  should be viewed as a disk of radius  $\varepsilon_p(x)$ , and the restriction of  $\rho_p$  to this disk is the square of the distance to the origin.

We set  $\mathbf{E}_p := T_p M$  so that  $\mathbf{E}_p$  is an  $m$ -dimensional Euclidean space equipped with an orthogonal decomposition

$$\mathbf{E}_p = \mathbf{E}_p^+ \oplus \mathbf{E}_p^-$$

determined by the eigenvectors of the hessian of  $f$  at  $p$  corresponding to positive/negative eigenvalues. For  $x \in \mathbf{E}_p$  we denote by  $x^\pm$  its components in  $\mathbf{E}_p^\pm$ .

As on page 225 we choose a coordinate neighborhood  $U_p$  of  $p \in M$  identified with a ball of radius  $2r_p$  in  $\mathbf{E}_p$ . Note that the restriction of  $\pi_p^-$  to  $U_p$  coincides with the orthogonal projection onto  $\mathbf{E}_p^-$ , while for any  $x \in U_p \cap \mathcal{J}_p$  we have

$$\rho_p(x) = |x^+|^2. \tag{4.24}$$

We denote by  $\delta_p$  the value of  $\varepsilon_p$  at  $p \in W_p^-$ . The Smale condition implies that any stable manifold intersects transversally all the strata of the stratification by unstable manifolds.

Let  $p \in \mathbf{Cr}_{f,k}$  and  $q \in \mathbf{Cr}_{f,k-1}$ . Note that if  $q \not\prec p$ , then  $\langle p|q \rangle = 0$  so we may as well assume that  $q \prec p$ , i.e.,  $W_q^- \subset \mathbf{cl}(W_p^-)$ . The restriction of  $\pi_q^-$  to  $W_p^- \cap \mathcal{T}_q$  is a locally trivial fibration with fiber described by the intersection

$$\mathcal{T}_q \cap W_p^- \cap W_q^+.$$

This is a finite collection of oriented arcs, one arc for every tunneling from  $p$  to  $q$ . For  $\kappa$  sufficiently small the set

$$W_{p,q}^-(\kappa) := W_p^- \setminus \{x \in \mathcal{T}_q; \rho_q(x) < \kappa^2 \varepsilon_q(\pi_q^- x)^2\}$$

is a smooth manifold with boundary. Intuitively,  $W_{p,q}^-(\kappa)$  is obtained from  $W_p^-$  by removing a very thin tube around  $W_q^-$ . The projection  $\pi_q^-$  induces a finite-to-one covering map

$$\pi_q^- : \partial W_{p,q}^-(\kappa) \rightarrow W_q^-.$$

Since  $W_q^-$  is contractible, this covering is trivial.

The fiber of this covering over  $q$  can be identified with the set of tunnelings from  $p$  to  $q$ . For any tunneling  $\bar{\gamma} \in M(p, q)$  we denote by  $x(\bar{\gamma}) = x(\bar{\gamma}, \kappa)$  its intersection with  $\partial W_{p,q}^-$ . Note that  $x(\bar{\gamma}, \kappa)$  is in the fiber of  $\pi_q^-$  over  $q$ , and it is the point on  $\bar{\gamma}$  situated at distance  $\kappa \delta_q$  from  $q$ . We denote by  $\partial_{\bar{\gamma}} W_{p,q}^-(\kappa)$  the component of  $\partial W_{p,q}^-(\kappa)$  containing  $x(\bar{\gamma}, \kappa)$ .

The orientation on  $W_p^-$  induces an orientation of  $\partial W_{p,q}^-(\kappa)$  via the outer-normal first rule. The vector field  $-\xi$  is tangent to  $W_{p,q}^-$  and transversal to  $\partial W_{p,q}^-(\kappa)$  at the points  $x(\bar{\gamma}, \kappa)$ . The equality (4.24) shows that it points towards the exterior of  $W_{p,q}^-(\kappa)$ . The orientation convention (4.22) shows that  $\epsilon(\bar{\gamma})$  is the degree of  $\pi_q^- : \partial_{\bar{\gamma}} W_{p,q}^-(\kappa) \rightarrow W_q^-$  at the point  $x(\bar{\gamma}, \kappa)$  or, equivalently,

$$\epsilon(\bar{\gamma}) = \deg(\pi_q^- : \partial_{\bar{\gamma}} W_{p,q}^-(\kappa) \rightarrow W_q^-).$$

For  $\kappa$  sufficiently small (to be specified a bit later) we set

$$W_p^-(\kappa) = W_p^- \setminus \bigcup_{x \in \mathcal{T}_q; q \in \mathbf{Cr}_{f,k-1}} \{\rho_q(x) < \kappa^2 \varepsilon_q(\pi_q^- x)^2\}.$$

This is a manifold with boundary. The components of the boundary are

$$\partial_{\bar{\gamma}} W_{p,q}^-(\kappa), \quad q \in \mathbf{Cr}_{f,k-1}, \quad \bar{\gamma} \in M(p, q).$$

Choose  $h \in (0, 1)$ . Let  $Y(\bar{\gamma}, \bar{\gamma}')$  be the hypersurface in  $\partial_{\bar{\gamma}} W_{p,q}^-(\kappa)$  (see Figure 4.13) defined as the preimage of  $\partial_{\bar{\gamma}'} W_{q,p'}(h)$  via the diffeomorphism



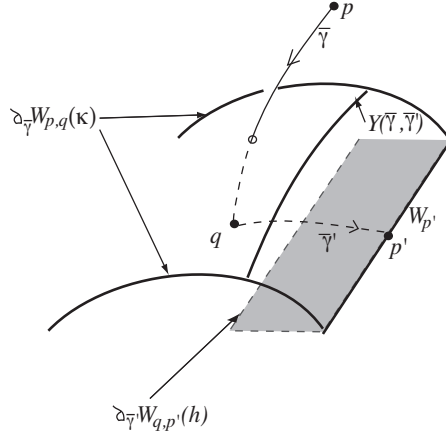

**Fig. 4.13.** The structure of  $M_p^-$  near  $W_p^-$ .

$$\pi_q^- : \partial_{\tilde{\gamma}} W_{p,q}^-(\kappa) \rightarrow W_q^-.$$

Since  $\pi_{p'}^- = \pi_{p'}^- \circ \pi_q^-$ , and the map  $\pi_{p'}^- : \partial_{\tilde{\gamma}'} W_{q,p'}^- \rightarrow W_{p'}^-$  is a diffeomorphism we obtain a diffeomorphism

$$\pi_{p'}^- : Y(\tilde{\gamma}, \tilde{\gamma}') \rightarrow W_{p'}^-.$$

We set

$$\sigma(\tilde{\gamma}, \tilde{\gamma}') := \deg(\pi_{p'}^- : Y(\tilde{\gamma}, \tilde{\gamma}') \rightarrow W_{p'}^-) \in \{\pm 1\}.$$

Since  $\rho_{p'} = \rho_{p'} \circ \pi_q^-$  we deduce that  $Y(\tilde{\gamma}, \tilde{\gamma}')$  is contained in the hypersurface of  $M$  described by

$$Z_{p',h} = \left\{ x \in \mathcal{T}_{p'}; \rho_{p'}(x) = h^2 \varepsilon_{p'}(\pi_{p'}^-(x)) \right\}.$$

Now fix  $\kappa$  small enough so that for any  $q \in \mathbf{Cr}_{f,k-1}$  and any tunneling  $\tilde{\gamma} \in C(p, q)$  the hypersurface  $Z_{p',h}$  intersects transversally the boundary component  $\partial_{\tilde{\gamma}} W_{p,q}^-$ . We then have a disjoint union

$$Z_{p',h} \cap \partial_{\tilde{\gamma}} W_{p,q}^- = \bigsqcup_{\tilde{\gamma}' \in M(q,p')} Y(\tilde{\gamma}, \tilde{\gamma}').$$

The hypersurface  $Z_{p',h}$  intersects transversally the manifold with boundary  $W_p^-(\kappa)$  and the intersection is a manifold with boundary. Moreover

$$\partial(Z_{p',h} \cap W_p^-(\kappa)) = \bigsqcup_{\substack{p' \prec q \prec p \\ \gamma \in M(p,q), \tilde{\gamma}' \in M(q,p')}} Y(\gamma, \gamma').$$

Let us observe that

$$\sigma(\bar{\gamma}, \bar{\gamma}') = \epsilon(\bar{\gamma}')\epsilon(\bar{\gamma}). \tag{4.25}$$

Indeed,

$$\begin{aligned} & \deg(\pi_{p'}^- : Y(\bar{\gamma}, \bar{\gamma}') \rightarrow W_{p'}^-) \\ &= \deg(\pi_{p'}^- : \partial_{\bar{\gamma}'} W_{q,p}^- (h) \rightarrow W_{p'}^-) \cdot \deg(\pi_q^- : Y(\bar{\gamma}, \bar{\gamma}') \rightarrow \partial_{\bar{\gamma}'} W_{q,p}^- (h)) \\ &= \epsilon(\bar{\gamma}')\epsilon(\bar{\gamma}). \end{aligned}$$

We orient  $Y(\bar{\gamma}, \bar{\gamma}')$  as a component of the boundary of  $Z_{p',h} \cap W_p^-(\kappa)$ . Fix a differential form  $\eta \in \Omega^{k-2}(W_{p'}^-)$  with support in a small neighborhood of  $p'$  and such that

$$\int_{W_{p'}^-} \eta = 1.$$

Then

$$\sigma(\bar{\gamma}, \bar{\gamma}') = \int_{Y(\bar{\gamma}, \bar{\gamma}')} (\pi_{p'}^-)^* \eta.$$

Hence

$$\begin{aligned} \sum_{\substack{p' \prec q \prec p \\ \gamma \in M(p,q), \bar{\gamma}' \in M(q,p')}} \sigma(\bar{\gamma}, \bar{\gamma}') &= \sum_{\substack{p' \prec q \prec p \\ \gamma \in M(p,q), \bar{\gamma}' \in M(q,p')}} \int_{Y(\bar{\gamma}, \bar{\gamma}')} (\pi_{p'}^-)^* \eta \\ &= \int_{\partial(Z_{p',h} \cap W_p^-(\kappa))} (\pi_{p'}^-)^* \eta = \int_{Z_{p',h} \cap W_p^-(\kappa)} d(\pi_{p'}^-)^* \eta. \end{aligned}$$

At the last step we have used Stokes formula and the fact that the map  $\pi_{p'}^- : Z_{p',h} \rightarrow W_{p'}^-$  is proper. The last integral is zero since  $d\eta = 0$  on  $W_{p'}^-$ . Using (4.25) in the above equality we obtain (4.23).  $\square$

The setup in the above proof yields a bit more information. Fix  $p' \prec p$ ,  $\lambda(p') = \lambda(p) - 2 = k - 2$ . Denote by  $M_p^-$  the closure of  $W_p^-$  in  $M$ . The closed set  $M_p^-$  has a canonical Whitney stratification with strata  $W_q^-$ ,  $q \preceq p$ .

The link in  $M_p^-$  of the  $(k - 2)$ -dimensional stratum  $W_{p'}^-$  is a compact one-dimensional Whitney stratified space  $\mathcal{L}_{p,p'}$  obtained by intersecting  $M_p^-$  with a small sphere

$$\mathbf{S}_{p'}^+(\varepsilon) = \{x^+ \in \mathbf{E}_{p'}^+; |x^+| = \varepsilon\} \subset U_{p'}.$$

The 0-dimensional strata of  $\mathcal{L}_{p,p'}$  are in bijective correspondence with tunneling  $\bar{\gamma}' \in C(q, p')$ ,  $p' \prec q \prec p$ . For such a tunneling  $\bar{\gamma}'$  we denote by  $v(\bar{\gamma}')$  the corresponding 0-dimensional stratum of  $\mathcal{L}_{p'}$ . The link of  $v(\bar{\gamma}')$  in  $\mathcal{L}_{p,p'}$  is in bijective correspondence with the tunnelings  $\bar{\gamma} \in C(p, q)$ . If from  $\mathcal{L}_{p'}$  we remove tubes around the 0-dimensional strata we obtain a 1-dimensional manifold with boundary that is homeomorphic to the space of broken trajectories  $\mathcal{M}(p, p')$ . Equivalently,  $\mathcal{M}(p, p')$  is homeomorphic to the space  $\widehat{\mathcal{L}}_{p,p'}$  obtained by blowing up  $\mathcal{L}_{p,p'}$  at the vertices; see Figure 4.14.

This provides another proof and a different explanation for Corollary 4.47.

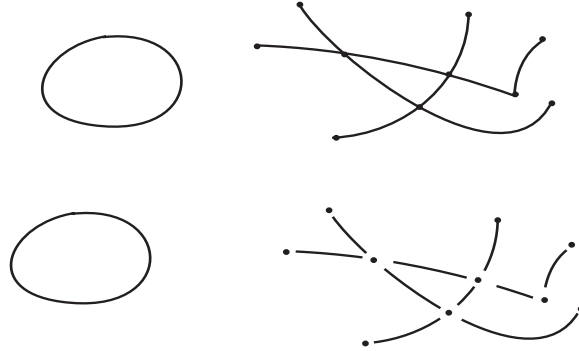

**Fig. 4.14.** The link  $\mathcal{L}_{p,p'}$  (top half) and its blowup along the 0-strata (bottom half).

**Corollary 4.50.** *Suppose  $p \in \mathbf{Cr}_{f,k}$  and  $p' \in \mathbf{Cr}_{f,k-2}$  are critical points of  $f$  such that  $p \succ p'$ . Denote by  $\mathcal{L}_{p,p'}$  the link of the stratum  $W_{p'}^-$  in the closure of  $W_p^-$ . Then  $\mathcal{L}_{p,p'}$  is a compact one-dimensional Whitney stratified space and  $\mathcal{M}(p,p')$  is homeomorphic to the blowup  $\widehat{\mathcal{L}}_{p,p'}$  of the link  $\mathcal{L}_{p,p'}$  along the 0-dimensional strata. This blowup is homeomorphic to a one-dimensional manifold with boundary. Moreover,*

$$\partial\mathcal{M}(p,p') = \bigcup_{q \in \mathbf{Cr}_{f,k-1}} M(p,q,p'). \quad \square$$

*Remark 4.51.* Suppose  $p' \prec p$ ,  $\lambda(p') = \lambda(p) - \nu - 1$ . Then the link of  $W_{p'}^-$  is a  $\nu$ -dimensional Whitney stratified space  $\mathcal{L}_{p,p'}$ . The link can be realized concretely as before by intersecting  $M_p^-$  with a small sphere  $\mathbf{S}_{p'}^+(\varepsilon) \subset W_{p'}^+$  centered at  $p'$ . The strata of the link are the connected components of the smooth manifolds

$$C(q,p')_\varepsilon = C(q,p') \cap \mathbf{S}_{p'}^+(\varepsilon), \quad p' \prec q \preceq p.$$

If  $S$  is a component of  $C(q,p')_\varepsilon$ , then the normal equisingularity of the Whitney stratification of  $M_p^-$  implies the link of  $S$  in  $\mathcal{L}_{p,p'}$  is homeomorphic with the link  $\mathcal{L}_{p,q}$  of  $W_q^-$  in  $M_p^-$ .  $\square$

*Remark 4.52.* F.B. Harvey and H.B. Lawson [HL] have shown that given a Morse function  $f$  on a compact manifold  $M$  we can find a smooth Riemann metric  $g$  on  $M$  such that the flow generated by  $-\nabla^g f$  satisfies the Morse-Smale condition and moreover, the unstable manifolds have finite volume with respect to the induced metric. By fixing orientations  $\text{or}_p$  on each unstable manifold  $W_p^-$ ,  $p \in \mathbf{Cr}_f$ , we obtain currents of integration  $[W_p^-, \text{or}_p]$ . The boundary (in the sense of currents) of  $[W_p^-, \text{or}_p]$  can be expressed in terms of the boundary of the Morse-Floer complex. More precisely,

$$\partial[W_p^-, \text{or}_p] = \sum_{\lambda(q)=\lambda(p)-1} \langle p|q \rangle [W_q^-, \text{or}_q]. \quad \square$$

*Remark 4.53.* The closure  $\mathbf{cl}(W_p^-)$  of an unstable manifold  $W_p^-$  of a Morse-Smale flow is typically a very singular Whitney stratified space. However, it admits a canonical resolution as a *smooth* manifold with corners. This consists of a pair  $(\widehat{W}_p^-, \sigma_p)$  with the following properties.

- $\widehat{W}_p^-$  is a smooth manifold with corners.
- $\sigma_p$  is a smooth map  $\sigma_p : \widehat{W}_p^- \rightarrow M$ .
- $\sigma_p(\widehat{W}_p^-) = \mathbf{cl}(W_p^-)$ .
- The restriction of  $\sigma_p$  to  $\widehat{W}_p^- \setminus \partial\widehat{W}_p^-$  is an injective immersion onto  $W_p^-$ .

To describe this resolution we follow closely the very nice presentation of [BFK] to which we refer for proofs and more details. A conceptually similar description can be found in [Qin].

As a set,  $\widehat{W}_p^-$  is a disjoint union

$$\widehat{W}_p^- = \bigsqcup_{q < p} \mathcal{M}(p, q) \times W_q^-, \quad \text{where } \mathcal{M}(p, p) = \{p\}.$$

The map  $\sigma_p$  is defined by its restriction to the strata. Along  $\mathcal{M}(p, q) \times W_q^-$  it is given by the composition

$$\mathcal{M}(p, q) \times W_q^- \rightarrow W_q^- \hookrightarrow M$$

where the first map is the canonical projection onto the second factor while the second is the canonical inclusion. We set

$$\widehat{f}_p := f \circ \sigma_p : \widehat{W}_p^- \rightarrow \mathbb{R}.$$

An element  $\widehat{w} := \widehat{W}_p^-$  can be viewed as a broken trajectory that “originate” at  $p$  and ends at  $x = \sigma_p(\widehat{w})$ . More precisely, we can identify  $\widehat{w}$  with a continuous map  $\gamma : [f(x), f(p)] \rightarrow M$  satisfying the following properties.

- The composition

$$[f(x), f(p)] \xrightarrow{\gamma} M \xrightarrow{f} \mathbb{R}$$

is the inclusion map  $[f(x), f(p)] \hookrightarrow \mathbb{R}$ .

- $\gamma(f(x)) = x, \gamma(f(p)) = p$ .
- If  $s_0 \in (f(x), f(p))$  is a regular value of  $f$ , then  $\gamma$  is differentiable at  $s_0$  and

$$\frac{d\gamma}{ds} \Big|_{s=s_0} = \frac{1}{df(\xi_{\gamma(s_0)})} \xi_{\gamma(s_0)}.$$

To describe the natural topology on  $\widehat{W}_p^-$  we first label the critical values of  $f$

$$c_0 < c_1 < \dots < c_\nu.$$

We set

$$c_{-1} := -\infty, \quad c_k := f(p), \quad \delta = \frac{1}{100} \min\{c_i - c_{i-1}; \quad 1 \leq i \leq \nu\},$$

and for  $j = 0, \dots, k - 1$  we define

$$\mathcal{U}_j = \widehat{f}_p^{-1}((c_{j-1} + \delta, c_{j+1} - \delta)).$$

We will describe topologies on  $\mathcal{U}_j$  that are compatible, i.e., for any  $j < j'$  the overlap  $\mathcal{U}_j \cap \mathcal{U}_{j'}$  is an open subset of both  $\mathcal{U}_j$  and  $\mathcal{U}_{j'}$ .

Observe that we have an inclusion

$$\tau_j : \mathcal{U}_j \hookrightarrow \{c_{j-1} + \delta < f < c_{j+1} - \delta\} \times \prod_{i=j+1}^k \{f = c_i - \delta\} \subset M^{k-j+1},$$

$$(\gamma, x) \mapsto (x, \gamma(c_{j+1} - \delta), \dots, \gamma(c_k - \delta)).$$

We equip  $\mathcal{U}_j$  with the topology as a subspace of  $M^{k-j+1}$ .

In [BFK, §2.3] it is shown that these topologies on  $\mathcal{U}_j$  are indeed compatible and  $\widehat{W}_p^-$  with the resulting topology is a compact Hausdorff space containing  $W_p^-$  as a dense open subset. The fact that  $\widehat{W}_p^-$  is a smooth manifold with corner follows from arguments very similar to the ones we have employed in §4.4. For details we refer to [BFK, §4.2].

Recently, Lizhen Qin has proved in [Qin] that the pair  $(\widehat{W}_p^-, \partial\widehat{W}_p^-)$  is homeomorphic to the pair  $(D^{\lambda(p)}, \partial D^{\lambda(p)})$ , where  $D^k$  denotes the closed unit disk in  $\mathbb{R}^k$ . In other words, the stratification by unstable manifolds is a bona-fide  $CW$ -decomposition of the manifold. Moreover, the cellular chain complex determined by his cellular decomposition of  $M$  coincides with the Morse-Floer complex.  $\square$



---

## Basics of Complex Morse Theory

In this final chapter we would like to introduce the reader to the complex version of Morse theory that has proved to be very useful in the study of the topology of complex projective varieties, and more recently in the study of the topology of symplectic manifolds.

The philosophy behind complex Morse theory is the same as that for the real Morse theory we have investigated so far. Given a complex submanifold  $M$  of a projective space  $\mathbb{C}\mathbb{P}^N$  we consider a (complex) 1-dimensional family of (projective) hyperplanes  $H_t$ ,  $t \in \mathbb{C}\mathbb{P}^1$  and we study the family of slices  $H_t \cap M$ . These slices are in fact the fibers of a holomorphic map  $f : M \rightarrow \mathbb{C}\mathbb{P}^1$ .

In this case the “time variable” is complex, and we cannot speak of sublevel sets. However, the whole setup is much more rigid, since all the objects involved are holomorphic, and we can still extract nontrivial information about the family of slices  $H_t \cap M$  from a finite collection of data, namely the behavior of the family near the singular slices, i.e., near those parameters  $\tau$  such that  $H_\tau$  does not intersect  $M$  transversally.

In the complex case the parameter  $t$  can approach a singular value  $\tau$  in a more sophisticated way, and the right information is no longer contained in one number (index of a Hessian) but in a morphism of groups called monodromy, which encodes how the homology of a slice  $H_t \cap M$  changes as  $t$  moves around a small loop surrounding a singular value  $\tau$ .

We can then use this local information to obtain surprising results relating the topology of  $M$  to the topology of a generic slice  $H_t \cap M$  and the singularities of the family.

To ease notation, in this chapter we will write  $\mathbb{P}^N$  instead of  $\mathbb{C}\mathbb{P}^N$ . For every complex vector space  $V$  we will denote by  $\mathbb{P}(V)$  its projectivization, i.e., the space of complex one dimensional subspaces in  $V$ . Thus  $\mathbb{P}^N = \mathbb{P}(\mathbb{C}^{N+1})$ . The dual of  $\mathbb{P}(V)$  is  $\mathbb{P}(V^*)$ , and it parametrizes the (projective) hyperplanes in  $\mathbb{P}(V)$ . We will denote the dual of  $\mathbb{P}(V)$  by  $\check{\mathbb{P}}(V)$ .

We will denote by  $\mathcal{P}_{d,N}$  the vector space of homogeneous complex polynomials of degree  $d$  in the variables  $z_0, \dots, z_N$ . Note that

$$\dim_{\mathbb{C}} \mathcal{P}_{d,N} = \binom{d+N}{d}.$$

We denote by  $\mathbb{P}(d, N)$  the projectivization of  $\mathcal{P}_{d,N}$ . Observe that  $\mathbb{P}(1, N) = \mathbb{P}^N$ .

## 5.1 Some Fundamental Constructions

Loosely speaking, a *linear system* on a complex manifold is a holomorphic family of divisors (i.e., complex hypersurfaces) parametrized by a projective space. Instead of a formal definition we will analyze a special class of examples. For more information we refer to [GH].

Suppose  $X \hookrightarrow \mathbb{P}^N$  is a compact submanifold of dimension  $n$ . Each polynomial  $P \in \mathcal{P}_{d,N} \setminus \{0\}$  determines a (possibly singular) hypersurface

$$\mathcal{Z}_P := \left\{ [z_0 : \dots : z_N] \in \mathbb{P}^N; P(z_0, \dots, z_N) = 0 \right\}.$$

The intersection  $X_P := X \cap \mathcal{Z}_P$  is a degree  $d$  hypersurface (thus a divisor) on  $X$ . Observe that  $\mathcal{Z}_P$  and  $X_P$  depend only on the image  $[P]$  of  $P$  in the projectivization  $\mathbb{P}(d, N)$  of  $\mathcal{P}_{d,N}$ .

Each projective subspace  $U \subset \mathbb{P}(d, N)$  defines a family  $(X_P)_{[P] \in U}$  of hypersurfaces on  $X$ . This is a *linear system*.<sup>1</sup> When  $\dim U = 1$ , i.e.,  $U$  is a projective line, we say that the family  $(X_P)_{P \in U}$  is a *pencil*. The intersection

$$B = B_U := \bigcap_{P \in U} X_P$$

is called the *base locus* of the linear system. The points in  $B$  are called *base points*.

Any point  $x \in X \setminus B$  determines a hyperplane  $H_x \subset U$  described by the equation

$$H_x := \{ P \in U; P(x) = 0 \}.$$

The hyperplane  $H_x$  determines a point in the dual projective space  $\check{U}$ . (Observe that if  $U$  is 1-dimensional then  $U = \check{U}$ .)

We see that a linear system determines a holomorphic map

$$f_U : X^* := X \setminus B \rightarrow \check{U}, \quad x \mapsto H_x.$$

We define the *modification of  $X$*  determined by the linear system  $(X_P)_{P \in U}$  to be the variety

$$\hat{X} = \hat{X}_U = \left\{ (x, H) \in X \times \check{U}; P(x) = 0, \forall P \in H \subset U \right\}.$$

<sup>1</sup> To be accurate, what we call a linear system is what algebraic geometers refer to as an *ample* linear system.



Equivalently, the modification of  $X$  determined by the linear system is the closure in  $X \times \check{U}$  of the graph of  $f_U$ . Very often,  $B$  and  $\hat{X}_U$  are not smooth objects.

When  $\dim U = 1$  the modification has the simpler description

$$\hat{X} = \hat{X}_U = \left\{ (x, P) \in X \times U; x \in \mathcal{Z}_P \right\}.$$

We have a pair of holomorphic maps  $\pi_X$  and  $\hat{f}_U$  induced by the natural projections:

$$\begin{array}{ccc} & \hat{X}_U \subset X \times \check{U} & \\ \pi_X \swarrow & & \searrow \hat{f}_U \\ X & \xrightarrow{\quad f_U \quad} & \check{U} \end{array}$$

When  $\dim U = 1$  the map  $\hat{f} : \hat{X} \rightarrow \check{U}$  can be regarded as a map to  $U$ .

The projection  $\pi_X$  induces a biholomorphic map  $\hat{X}^* := \pi_X^{-1}(X^*) \rightarrow X^*$  and we have a commutative diagram

$$\begin{array}{ccc} & \hat{X}^* & \\ \pi_X \swarrow & & \searrow \hat{f}_U \\ X^* & \xrightarrow{\quad f_U \quad} & \check{U} \end{array} .$$

*Remark 5.1.* When studying linear systems defined by projective subspaces  $U \subset \mathbb{P}(d, N)$  it suffices to consider only the case  $d = 1$ , i.e. linear systems of hyperplanes.

To see this, define for  $\mathbf{z} \in \mathbb{C}^{N+1} \setminus \{0\}$  and  $\omega = (\omega_0, \dots, \omega_N) \in \mathbb{Z}_+^{N+1}$

$$|\omega| = \sum_{i=0}^N \omega_i, \quad \mathbf{z}^\omega = \prod_{i=0}^N z_i^{\omega_i} \in \mathcal{P}_{|\omega|, N}.$$

Any  $P = \sum_{|\omega|=d} p_\omega \mathbf{z}^\omega \in \mathcal{P}_{d, N}$  defines a hyperplane in  $\check{\mathbb{P}}(d, N)$ ,

$$H_P = \left\{ [z_\omega] \in \check{\mathbb{P}}(d, N); \sum_{|\omega|=d} p_\omega z_\omega = 0 \right\}.$$

We have the *Veronese embedding*

$$\mathbf{V}_{d, N} : \mathbb{P}^N \hookrightarrow \check{\mathbb{P}}(d, N), \quad [\mathbf{z}] \mapsto [(z_\omega)] := [(\mathbf{z}^\omega)_{|\omega|=d}]. \tag{5.1}$$

Observe that  $\mathbf{V}(\mathcal{Z}_P) \subset H_P$ , so that  $\mathbf{V}(X \cap \mathcal{Z}_P) = \mathbf{V}(X) \cap H_P$ . □

**Definition 5.2.** A Lefschetz pencil on  $X \hookrightarrow \mathbb{P}^N$  is a pencil determined by a one dimensional projective subspace  $U \hookrightarrow \mathbb{P}(d, N)$  with the following properties.

(a) The base locus  $B$  is either empty or it is a smooth, complex codimension two submanifold of  $X$ .

(b)  $\hat{X}$  is a smooth manifold.

(c) The holomorphic map  $\hat{f} : \hat{X} \rightarrow U$  is a nonresonant Morse function, i.e., no two critical points correspond to the same critical value and for every critical point  $x_0$  of  $\hat{f}$  there exist holomorphic coordinates  $(z_j)$  near  $x_0$  and a holomorphic coordinate  $u$  near  $\hat{f}(x_0)$  such that

$$u \circ \hat{f} = \sum_j z_j^2.$$

The map  $\hat{X} \rightarrow S$  is called the Lefschetz fibration associated with the Lefschetz pencil. If the base locus is empty,  $B = \emptyset$ , then  $\hat{X} = X$  and the Lefschetz pencil is called a Lefschetz fibration.  $\square$

We have the following genericity result. Its proof can be found in [Lam, Section 2].

**Theorem 5.3.** Fix a compact complex submanifold  $X \hookrightarrow \mathbb{P}^N$ . Then for any generic projective line  $U \subset \mathbb{P}(d, N)$ , the pencil  $(X_P)_{P \in U}$  is Lefschetz.  $\square$

According to Remark 5.1, it suffices to consider only pencils generated by degree 1 polynomials. In this case, the pencils can be given a more visual description.

Suppose  $X \hookrightarrow \mathbb{P}^N$  is a compact complex manifold. Fix a codimension two projective subspace  $A \hookrightarrow \mathbb{P}^N$  called the *axis*. The hyperplanes containing  $A$  form a one dimensional projective space  $U \subset \mathbb{P}^N \cong \mathbb{P}(1, N)$ . It can be identified with any line in  $\mathbb{P}^N$  that does not intersect  $A$ . Indeed, if  $S$  is such a line (called a *screen*), then any hyperplane  $H$  containing  $A$  intersects  $S$  in a single point  $s(H)$ . We have thus produced a map

$$U \ni H \mapsto s(H) \in S.$$

Conversely, any point  $s \in S$  determines a unique hyperplane  $[As]$  containing  $A$  and passing through  $s$ . The correspondence

$$S \ni s \mapsto [As] \in U$$

is the inverse of the above map; see Figure 5.1. The base locus of the linear system

$$(X_s = [As] \cap X)_{s \in S}$$

is  $B = X \cap A$ . All the hypersurfaces  $X_s$  pass through the base locus  $B$ . For generic  $A$  this is a smooth codimension 2 submanifold of  $X$ .

We have a natural map

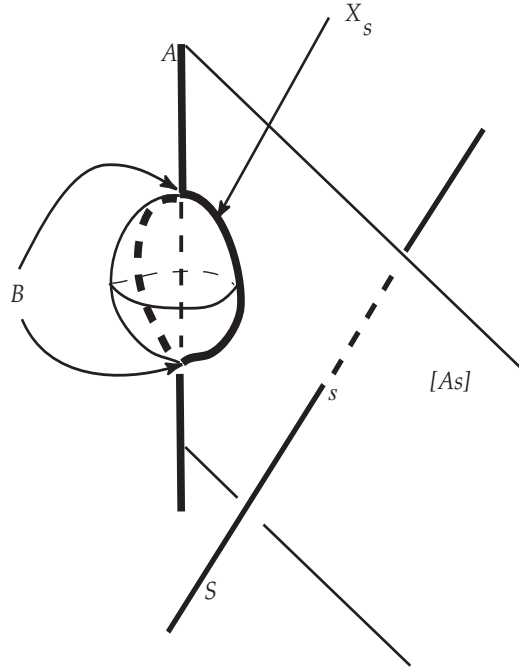

**Fig. 5.1.** Projecting onto the “screen”  $S$ .

$$f : X \setminus B \rightarrow S, \quad X \setminus Bx \mapsto S \cap [Ax] \in S.$$

We can now define the elementary modification of  $X$  to be the incidence variety

$$\hat{X} := \{(x, s) \in X \times S; x \in X_s\}.$$

The critical points of  $\hat{f}$  correspond to the hyperplanes through  $A$  that contain a tangent (projective) plane to  $X$ . We have a diagram

$$\begin{array}{ccc} & \hat{X} & \\ \pi \swarrow & & \searrow \hat{f} \\ X & \overset{f}{\dashrightarrow} & S \end{array}$$

We define  $\hat{B} := \pi^{-1}(B)$ . Observe that

$$\hat{B} = \{(b, s) \in B \times S; b \in [As]\} = B \times S,$$

and the natural projection  $\pi : \hat{B} \rightarrow B$  coincides with the projection  $B \times S \rightarrow B$ . Set  $\hat{X}_s := \hat{f}^{-1}(s)$ .

The projection  $\pi$  induces a homeomorphism  $\hat{X}_s \rightarrow X_s$ .

**Example 5.4 (Pencils of lines).** Suppose  $X$  is the projective plane

$$\{z_3 = 0\} \cong \mathbb{P}^2 \hookrightarrow \mathbb{P}^3.$$

Assume  $A$  is the line  $z_1 = z_2 = 0$  and  $S$  is the line  $z_0 = z_3 = 0$ . The base locus consists of the single point  $B = [1 : 0 : 0 : 0] \in X$ . The pencil obtained in this fashion consists of all lines passing through  $B$ .

Observe that  $S \subset X \cong \mathbb{P}^2$  can be identified with the line at  $\infty$  in  $\mathbb{P}^2$ . The map  $f : X \setminus \{B\} \rightarrow S$  determined by this pencil is simply the projection onto the line at  $\infty$  with center  $B$ . The modification of  $X$  defined by this pencil is called the *blowup* of  $\mathbb{P}^2$  at  $B$ .  $\square$

**Example 5.5 (Pencils of cubics).** Consider two homogeneous cubic polynomials  $A, B \in \mathcal{P}_{3,2}$  (in the variables  $z_0, z_1, z_2$ ). For generic  $A, B$  these are smooth cubic curves in  $\mathbb{P}^2$ . (The genus formula in Corollary 5.14 will show that they are homeomorphic to tori.) By Bézout's theorem, these two general cubics meet in 9 distinct points,  $p_1, \dots, p_9$ . For  $\mathbf{t} := [t_0 : t_1] \in \mathbb{P}^1$  set

$$C_{\mathbf{t}} := \{[z_0 : z_1 : z_2] \in \mathbb{P}^2; t_0 A(z_0, z_1, z_2) + t_1 B(z_0, z_1, z_2) = 0\}.$$

The family  $C_{\mathbf{t}}$ ,  $\mathbf{t} \in \mathbb{P}^1$ , is a pencil on  $X = \mathbb{P}^2$ . The base locus of this system consists of the nine points  $p_1, \dots, p_9$  common to all these cubics. The modification

$$\hat{X} := \left\{ ([z_0, z_1, z_2], \mathbf{t}) \in \mathbb{P}^2 \times \mathbb{P}^1; t_0 A(z_0, z_1, z_2) + t_1 B(z_0, z_1, z_2) = 0 \right\}$$

is isomorphic to the blowup of  $X$  at these nine points,

$$\hat{X} \cong \hat{X}_{p_1, \dots, p_9}.$$

For general  $A, B$  the induced map  $\hat{f} \rightarrow \mathbb{P}^1$  is a Morse map, and its generic fiber is an elliptic curve. The manifold  $\hat{X}$  is a basic example of an *elliptic fibration*. It is usually denoted by  $E(1)$ .  $\square$

## 5.2 Topological Applications of Lefschetz Pencils

All of the results in this section originate in the remarkable work of S. Lefschetz [Lef] in the 1920s. We follow the modern presentation in [Lam]. In this section, unless otherwise stated,  $H_{\bullet}(X)$  (respectively  $H^{\bullet}(X)$ ) will denote the *integral* singular homology (respectively cohomology) of the space  $X$ .

Before we proceed with our study of Lefschetz pencils we want to mention two important results, frequently used in the sequel. The first one is called the *Ehresmann fibration theorem* [Ehr].

**Theorem 5.6.** *Suppose  $\Phi : E \rightarrow B$  is a smooth map between two smooth manifolds such that*

- $\Phi$  is proper, i.e.,  $\Phi^{-1}(K)$  is compact for every compact  $K \subset B$ .
- $\Phi$  is a submersion.
- If  $\partial E \neq \emptyset$  then the restriction  $\partial\Phi$  of  $\Phi$  to  $\partial E$  continues to be a submersion.

*Then  $\Phi : (E, \partial E) \rightarrow B$  is a locally trivial, smooth fiber bundle.  $\square$*

The second result needed in the sequel is a version of the excision theorem for singular homology, [Spa, Theorems 6.6.5 and 6.1.10].

**Theorem 5.7 (Excision).** *Suppose  $f(X, A) \rightarrow (Y, B)$  is a continuous mapping between compact ENR pairs<sup>2</sup> such that*

$$f : X \setminus A \rightarrow Y \setminus B$$

*is a homeomorphism. Then  $f$  induces an isomorphism*

$$f_* : H_\bullet(X, A; \mathbb{Z}) \rightarrow H_\bullet(Y, B; \mathbb{Z}). \quad \square$$

*Remark 5.8.* For every compact oriented,  $m$ -dimensional manifold  $M$  denote by  $PD_M$  the Poincaré duality map

$$H^q(M) \rightarrow H_{m-q}(M), \quad u \mapsto u \cap [M].$$

The sign conventions for the  $\cap$ -product follow from the definition

$$\langle v \cup u, c \rangle = \langle v, u \cap c \rangle,$$

where  $\langle -, - \rangle$  denotes the Kronecker pairing between singular cochains and chains.

Observe that if  $f : X \rightarrow Y$  is a continuous map between topological spaces, then for every chain  $c$  in  $X$  and cochains  $u, v$  in  $Y$ ,

$$\begin{aligned} \langle v, u \cap p_*(c) \rangle &= \langle u \cup v, p_*(c) \rangle = \langle p^*(u) \cup p^*(v), c \rangle \\ &= \langle p^*(v), p^*(u) \cap c \rangle = \langle v, p_*(p^*(u) \cap c) \rangle, \end{aligned}$$

so that we obtain the *projection formula*

$$p_*(p^*(u) \cap c) = u \cap p_*(c). \quad (5.2)$$

$\square$

Suppose  $X \hookrightarrow \mathbb{P}^N$  is an  $n$ -dimensional algebraic manifold, and  $S \subset \mathbb{P}(d, N)$  is a one dimensional projective subspace defining a Lefschetz pencil  $(X_s)_{s \in S}$  on  $X$ . As usual, denote by  $B$  the base locus

<sup>2</sup> E.g.,  $(X, A)$  is a compact ENR pair if  $X$  is a compact CW-complex and  $A$  is a subcomplex.

$$B = \bigcap_{s \in S} X_s$$

and by  $\hat{X}$  the modification

$$\hat{X} = \left\{ (x, s) \in X \times S; x \in X_s \right\}.$$

We have an induced *Lefschetz fibration*  $\hat{f} : \hat{X} \rightarrow S$  with fibers  $\hat{X}_s := \hat{f}^{-1}(s)$ , and a surjection  $p : \hat{X} \rightarrow X$  that induces homeomorphisms  $\hat{X}_s \rightarrow X_s$ . Observe that  $\deg p = 1$ . Set

$$\hat{B} := p^{-1}(B).$$

We have a tautological diffeomorphism

$$\hat{B} \cong B \times S, \quad \hat{B} \ni (x, s) \mapsto (x, s) \in B \times S.$$

Since  $S \cong S^2$  we deduce from Künneth's theorem that we have an isomorphism

$$H_q(\hat{B}) \cong H_q(B) \oplus H_{q-2}(B)$$

and a natural injection

$$H_{q-2}(B) \rightarrow H_q(\hat{B}), \quad H_{q-2}(B) \ni c \mapsto c \times [S] \in H_q(\hat{B}).$$

Using the inclusion map  $\hat{B} \rightarrow \hat{X}$  we obtain a natural morphism

$$\kappa : H_{q-2}(B) \rightarrow H_q(\hat{X}).$$

**Lemma 5.9.** *The sequence*

$$0 \rightarrow H_{q-2}(B) \xrightarrow{\kappa} H_q(\hat{X}) \xrightarrow{p_*} H_q(X) \rightarrow 0 \tag{5.3}$$

*is exact and splits for every  $q$ . In particular,  $\hat{X}$  is connected iff  $X$  is connected and*

$$\chi(\hat{X}) = \chi(X) + \chi(B).$$

*Proof.* The proof will be carried out in several steps.

**Step 1**  $p_*$  admits a natural right inverse. Consider the Gysin morphism

$$p^! : H_q(X) \rightarrow H_q(\hat{X}), \quad p^! = PD_{\hat{X}} p^* PD_X^{-1},$$

so that the diagram below is commutative:

$$\begin{array}{ccc} H^{2n-q}(X) & \xrightarrow{\cap[X]} & H_q(X) \\ \downarrow p^* & & \downarrow p^! \\ H^{2n-q}(\hat{X}) & \xrightarrow{\cap[\hat{X}]} & H_q(\hat{X}) \end{array}$$

We will show that  $p_*p^! = \mathbb{1}$ . Let  $c \in H_q(X)$  and set  $u := PD_X^{-1}(c)$ , that is,  $u \cap [X] = c$ . Then

$$p^!(c) = PD_{\hat{X}}p^*u = p^*(u) \cap [\hat{X}]$$

and

$$p_*p^!(c) = p_*(p^*(u) \cap [\hat{X}]) \stackrel{(5.2)}{=} u \cap p_*([\hat{X}]) = \deg p(u \cap [X]) = c.$$

**Step 2. Conclusion.** We use the long exact sequences of the pairs  $(\hat{X}, \hat{B})$ ,  $(X, B)$  and the morphism between them induced by  $p_*$ . We have the following commutative diagram:

$$\begin{array}{ccccc} H_{q+1}(\hat{X}) & \longrightarrow & H_{q+1}(\hat{X}, \hat{B}) & \xrightarrow{\partial} & H_q(B) \oplus H_{q-2}(B) \longrightarrow \\ \downarrow p_* & & \downarrow p'_* & & \downarrow \mathbf{pr} \\ H_{q+1}(X) & \longrightarrow & H_{q+1}(X, B) & \xrightarrow{\partial} & H_q(B) \longrightarrow \end{array}$$

$$\begin{array}{ccc} \cdots \longrightarrow H_q(\hat{X}) & \longrightarrow & H_q(\hat{X}, \hat{B}) \\ \downarrow p_* & & \downarrow p'_* \\ \cdots \longrightarrow H_q(X) & \longrightarrow & H_q(X, B) \end{array}$$

The excision theorem shows that the morphisms  $p'_*$  are isomorphisms. Moreover,  $p_*$  is surjective. The conclusion in the lemma now follows by diagram chasing.  $\square$

Decompose the projective line  $S$  into two closed hemispheres

$$S := D_+ \cup D_-, \quad E = D_+ \cap D_-, \quad \hat{X}_\pm := \hat{f}^{-1}(D_\pm), \quad \hat{X}_E := \hat{f}^{-1}(E)$$

such that all the critical values of  $\hat{f} : \hat{X} \rightarrow S$  are contained in the interior of  $D_+$ . Choose a point  $*$  on the equator  $E = \partial D_+ \cong \partial D_- \cong S^1$ . Denote by  $r$  the number of critical points (= the number of critical values) of the Morse function  $\hat{f}$ . In the remainder of this chapter we will assume the following fact. Its proof is deferred to a later section.

**Lemma 5.10.**

$$H_q(\hat{X}_+, \hat{X}_*) \cong \begin{cases} 0 & \text{if } q \neq n = \dim_{\mathbb{C}} X, \\ \mathbb{Z}^r & \text{if } q = n. \end{cases}$$

*Remark 5.11.* The number  $r$  of nondegenerate singular points of a Lefschetz pencil defined by *linear polynomials* is a projective invariant of  $X$  called the *class* of  $X$ . For more information about this projective invariant we refer to [GKZ].  $\square$

Using the Ehresmann fibration theorem we deduce

$$\hat{X}_- \cong \hat{X}_* \times D_-, \quad \partial\hat{X}_\pm \cong \hat{X}_* \times \partial D_-,$$

so that

$$(\hat{X}_-, \hat{X}_E) \cong \hat{X}_* \times (D_-, E).$$

Clearly,  $\hat{X}_*$  is a deformation retract of  $\hat{X}_-$ . In particular, the inclusion  $\hat{X}_* \hookrightarrow \hat{X}_-$  induces isomorphisms

$$H_\bullet(\hat{X}_*) \cong H_\bullet(\hat{X}_-).$$

Using excision and the Künneth formula we obtain the sequence of isomorphisms

$$H_{q-2}(\hat{X}_*) \xrightarrow{\times[D_-, E]} H_q(\hat{X}_* \times (D_-, E)) \cong H_q(\hat{X}_-, \hat{X}_E) \xrightarrow{\text{excis}} H_q(\hat{X}, \hat{X}_+). \quad (5.4)$$

Consider now the long exact sequence of the triple  $(\hat{X}, \hat{X}_+, \hat{X}_*)$ ,

$$\cdots \rightarrow H_{q+1}(\hat{X}_+, \hat{X}_*) \rightarrow H_{q+1}(\hat{X}, \hat{X}_*) \rightarrow H_{q+1}(\hat{X}, \hat{X}_+) \xrightarrow{\partial} H_q(\hat{X}_+, \hat{X}_*) \rightarrow \cdots.$$

If we use Lemma 5.10 and the isomorphism (5.4) we deduce that we have the isomorphisms

$$L : H_{q+1}(\hat{X}, \hat{X}_*) \rightarrow H_{q-1}(\hat{X}_*), \quad q \neq n, n-1, \quad (5.5)$$

and the 5-term exact sequence

$$\begin{aligned} 0 \rightarrow H_{n+1}(\hat{X}, \hat{X}_*) \rightarrow H_{n-1}(\hat{X}_*) \rightarrow H_n(\hat{X}_+, \hat{X}_*) \rightarrow \\ \rightarrow H_n(\hat{X}, \hat{X}_*) \rightarrow H_{n-2}(\hat{X}_*) \rightarrow 0. \end{aligned} \quad (5.6)$$

Here is a first nontrivial consequence.

**Corollary 5.12.** *If  $X$  is connected and  $n = \dim_{\mathbb{C}} X > 1$ , then the generic fiber  $\hat{X}_* \cong X_*$  is connected.*

*Proof.* Using (5.5) we obtain the isomorphisms

$$H_0(\hat{X}, \hat{X}_*) \cong H_{-2}(\hat{X}_*) = 0, \quad H_1(\hat{X}, \hat{X}_*) \cong H_{-1}(\hat{X}_*) = 0.$$

Using the long exact sequence of the pair  $(\hat{X}, \hat{X}_*)$  we deduce that  $H_0(\hat{X}_*) \cong H_0(\hat{X})$ . Since  $X$  is connected, Lemma 5.9 now implies  $H_0(\hat{X}) = 0$ , thus proving the corollary.  $\square$



**Corollary 5.13.**

$$\chi(\hat{X}) = 2\chi(\hat{X}_*) + (-1)^n r, \quad \chi(X) = 2\chi(X_*) - \chi(B) + (-1)^n r.$$

**Proof** From (5.3) we deduce  $\chi(\hat{X}) = \chi(X) + \chi(B)$ . On the other hand, the long exact sequence of the pair  $(\hat{X}, \hat{X}_*)$  implies

$$\chi(\hat{X}) - \chi(\hat{X}_*) = \chi(\hat{X}, \hat{X}_*).$$

Using (5.5), (5.6), and the Lemma 5.10 we deduce

$$\chi(\hat{X}, \hat{X}_*) = \chi(\hat{X}_*) + (-1)^n r.$$

Thus

$$\chi(\hat{X}) = 2\chi(\hat{X}_*) + (-1)^n r \quad \text{and} \quad \chi(X) = 2\chi(\hat{X}_*) - \chi(B) + (-1)^n r. \quad \square$$

**Corollary 5.14 (Genus formula).** *For a generic degree  $d$  homogeneous polynomial  $P \in \mathcal{P}_{d,2}$ , the plane curve*

$$C_P := \{ [z_0, z_1, z_2] \in \mathbb{P}^2; P(z_0, z_1, z_2) = 0 \}$$

*is a smooth Riemann surface of genus*

$$g(C_P) = \frac{(d-1)(d-2)}{2}.$$

**Proof** Fix a projective line  $\mathbb{L} \subset \mathbb{P}^2$  and a point  $c \in \mathbb{P}^2 \setminus (C_P \cup \mathbb{L})$ . We get a pencil of projective lines  $\{[c\ell]; \ell \in \mathbb{L}\}$  and a projection map  $f = f_c : C_P \rightarrow \mathbb{L}$ , where for every  $x \in C_P$  the point  $f(x)$  is the intersection of the projective line  $[cx]$  with  $\mathbb{L}$ . In this case we have no base locus, i.e.,  $B = \emptyset$  and  $X = \hat{X} = V_P$ . Since every generic line intersects  $C_P$  in  $d$  points, we deduce that  $f$  is a degree  $d$  holomorphic map. A point  $x \in C_P$  is a critical point of  $f_c$  if and only if the line  $[cx]$  is tangent to  $C_P$ .

For generic  $c$  the projection  $f_c$  defines a Lefschetz fibration. Modulo a linear change of coordinates we can assume that all the critical points are situated in the region  $z_0 \neq 0$  and  $c$  is the point at infinity  $[0 : 1 : 0]$ .

In the affine plane  $z_0 \neq 0$  with coordinates  $x = z_1/z_0, y = z_2/z_0$ , the point  $c \in \mathbb{P}^2$  corresponds to the point at infinity on the lines parallel to the  $x$ -axis ( $y = 0$ ). In this region the curve  $C_P$  is described by the equation

$$F(x, y) = 0,$$

where  $F(x, y) = P(1, x, y)$  is a degree  $d$  inhomogeneous polynomial.

The critical points of the projection map are the points  $(x, y)$  on the curve  $F(x, y) = 0$  where the tangent is horizontal,

$$0 = \frac{dy}{dx} = -\frac{F'_x}{F'_y}.$$

Thus, the critical points are solutions of the system of polynomial equations

$$\begin{cases} F(x, y) = 0, \\ F'_x(x, y) = 0. \end{cases}$$

The first polynomial has degree  $d$ , while the second polynomial has degree  $d - 1$ . For generic  $P$  this system will have exactly  $d(d - 1)$  distinct solutions. The corresponding critical points will be nondegenerate. Using Corollary 5.13 with  $X = \hat{X} = C_P$ ,  $r = d(d - 1)$ , and  $X_*$  a finite set of cardinality  $d$  we deduce

$$2 - 2(g(C_P) = \chi(C_P) = 2d - d(d - 1)$$

so that

$$g(C_P) = \frac{(d - 1)(d - 2)}{2}. \quad \square$$

**Example 5.15.** Consider again two generic cubic polynomials  $A, B \in \mathcal{P}_{3,2}$  as in Example 5.5 defining a Lefschetz pencil on  $\mathbb{P}^2 \hookrightarrow \mathbb{P}^3$ . We can use the above Corollary 5.13 to determine the number  $r$  of singular points of this pencil. More precisely, we have

$$\chi(\mathbb{P}^2) = 2\chi(X_*) - \chi(B) + r.$$

We have seen that  $B$  consists of 9 distinct points. The generic fiber is a degree 3 plane curve, so by the genus formula it must be a torus. Hence  $\chi(X_*) = 0$ . Finally,  $\chi(\mathbb{P}^2) = 3$ . We deduce  $r = 12$ , so that the generic elliptic fibration  $\hat{\mathbb{P}}^2_{p_1, \dots, p_9} \rightarrow \mathbb{P}^1$  has 12 singular fibers.  $\square$

We can now give a new proof of the Lefschetz hyperplane theorem.

**Theorem 5.16.** *Suppose  $X \subset \mathbb{P}^N$  is a smooth projective variety of (complex) dimension  $n$ . Then for any hyperplane  $H \subset \mathbb{P}^N$  intersecting  $X$  transversally the inclusion  $X \cap H \hookrightarrow X$  induces isomorphisms*

$$H_q(X \cap H) \rightarrow H_q(X)$$

if  $q < \frac{1}{2} \dim_{\mathbb{R}}(X \cap H) = n - 1$  and an epimorphism if  $q = n - 1$ . Equivalently, this means that

$$H_q(X, X \cap H) = 0, \quad \forall q \leq n - 1.$$

*Proof.* Choose a codimension two projective subspace  $A \subset \mathbb{P}^N$  such that the pencil of hyperplanes in  $\mathbb{P}^N$  containing  $A$  defines a Lefschetz pencil on  $X$ . Then the base locus  $B = A \cap X$  is a smooth codimension two complex submanifold of  $X$  and the modification  $\hat{X}$  is smooth as well.

A transversal hyperplane section  $X \cap H$  is diffeomorphic to a generic divisor  $X_*$  of the Lefschetz pencil, or to a generic fiber  $\hat{X}_*$  of the associated Lefschetz fibration  $\hat{f} : \hat{X} \rightarrow S$ , where  $S$  denotes the projective line in  $\check{\mathbb{P}}^N = \mathbb{P}(1, N)$  dual to  $A$ .

Using the long exact sequence of the pair  $(X, X_*)$  we see that it suffices to show that

$$H_q(X, X_*) = 0, \quad \forall q \leq n - 1.$$

We analyze the long exact sequence of the triple  $(\hat{X}, \hat{X}_+ \cup \hat{B}, \hat{X}_* \cup \hat{B})$ . We have

$$H_q(\hat{X}, \hat{X}_+ \cup \hat{B}) = H_q(\hat{X}, \hat{X}_+ \cup B \times D_-) \stackrel{excis}{\cong} H_q(\hat{X}_-, \hat{X}_E \cup B \times D_-)$$

(use the Ehresmann fibration theorem)

$$\cong H_q((X_*, B) \times (D_-, E)) \cong H_{q-2}(X_*, B).$$

Using the excision theorem again we obtain an isomorphism

$$p_* : H_q(\hat{X}, \hat{X}_* \cup \hat{B}) \cong H_q(X, X_*).$$

Finally, we have an isomorphism

$$H_\bullet(\hat{X}_+ \cup \hat{B}, \hat{X}_* \cup \hat{B}) \cong H_\bullet(\hat{X}_+, \hat{X}_*). \tag{5.7}$$

Indeed, excise  $B \times \text{Int}(D_-)$  from both terms of the pair  $(\hat{X}_+ \cup \hat{B}, \hat{X}_* \cup \hat{B})$ . Then

$$\hat{X}_+ \cup \hat{B} \setminus (B \times \text{Int}(D_-)) = \hat{X}_+,$$

and since  $\hat{X}_* \cap \hat{B} = \{*\} \times B$ , we deduce

$$\hat{X}_* \cup \hat{B} \setminus (B \times \text{Int}(D_-)) = \hat{X}_* \cup (D_+ \times B).$$

Observe that  $\hat{X}_* \cap (D_+ \times B) = \{*\} \times B$  and that  $D_+ \times B$  deformation retracts to  $\{*\} \times B$ . Hence  $\hat{X}_* \cup (D_+ \times B)$  is homotopically equivalent to  $\hat{X}_*$  thus proving (5.7).

The long exact sequence of the triple  $(\hat{X}, \hat{X}_+ \cup \hat{B}, \hat{X}_* \cup \hat{B})$  can now be rewritten

$$\cdots \rightarrow H_{q-1}(X_*, B) \xrightarrow{\partial} H_q(\hat{X}_+, \hat{X}_*) \rightarrow H_q(X, X_*) \rightarrow H_{q-2}(X_*, B) \xrightarrow{\partial} \cdots$$

Using the Lemma 5.10 we obtain the isomorphisms

$$L' : H_q(X, X_*) \rightarrow H_{q-2}(X_*, B), \quad q \neq n, n+1, \quad (5.8)$$

and the 5-term exact sequence

$$\begin{aligned} 0 \rightarrow H_{n+1}(X, X_*) \rightarrow H_{n-1}(X_*, B) \rightarrow H_n(\hat{X}_+, \hat{X}_*) \rightarrow \\ \rightarrow H_n(X, X_*) \rightarrow H_{n-2}(X_*, B) \rightarrow 0. \end{aligned} \quad (\boxtimes)$$

We now argue by induction on  $n$ . The result is obviously true for  $n = 1$ .

For the inductive step, observe first that  $B$  is a transversal hyperplane section of  $X_*$ ,  $\dim_{\mathbb{C}} X_* = n - 1$  and thus by induction we deduce that

$$H_q(X_*, B) = 0, \quad \forall q \leq n - 2.$$

Using (5.8) we deduce

$$H_q(X, X_*) \cong H_{q-2}(X_*, B) \cong 0, \quad \forall q \leq n - 1. \quad \square$$

**Corollary 5.17.** *If  $X$  is a hypersurface in  $\mathbb{P}^n$ , then*

$$b_k(X) = b_k(\mathbb{P}^n), \quad \forall k \leq n - 2.$$

*In particular, if  $X$  is a hypersurface in  $\mathbb{P}^3$ , then  $b_1(X) = 0$ .* □

Consider the connecting homomorphism

$$\partial : H_n(\hat{X}_+, \hat{X}_*) \rightarrow H_{n-1}(\hat{X}_*).$$

Its image

$$\mathbb{V}(X_*) := \partial \left( H_n(\hat{X}_+, \hat{X}_*) \right) = \ker \left( H_{n-1}(\hat{X}_*) \rightarrow H_{n-1}(\hat{X}) \right) \subset H_{n-1}(\hat{X}_*)$$

is called the module of *vanishing*<sup>3</sup> *cycles*.

Using the long exact sequences of the pairs  $(\hat{X}_+, \hat{X}_*)$  and  $(X, X_*)$  and Lemma 5.10 we obtain the following commutative diagram:

$$\begin{array}{ccccccc} H_n(\hat{X}_+, \hat{X}_*) & \xrightarrow{\partial} & H_{n-1}(\hat{X}_*) & \longrightarrow & H_{n-1}(\hat{X}_+) & \longrightarrow & 0 \\ \downarrow p_1 & & \cong \downarrow p_2 & & \cong \downarrow p_3 & & \\ H_n(X, X_*) & \xrightarrow{\partial} & H_{n-1}(X_*) & \longrightarrow & H_{n-1}(X) & \longrightarrow & 0 \end{array}$$

All the vertical morphisms are induced by the map  $p : \hat{X} \rightarrow X$ . The morphism  $p_1$  is onto because it appears in the sequence  $(\boxtimes)$ , where  $H_{n-2}(X_*, B) = 0$  by the Lefschetz hyperplane theorem. Clearly  $p_2$  is an isomorphism since  $p$

<sup>3</sup> They are called vanishing because they “melt” when pushed inside  $\hat{X}$ .

induces a homeomorphism  $\hat{X}_* \cong X_*$ . Using the refined five lemma [Mac, Lemma I.3.3] we conclude that  $p_3$  is an isomorphism. The above diagram shows that

$$\begin{aligned} \mathbb{V}(X_*) &= \ker\left(i_* : H_{n-1}(X_*) \rightarrow H_{n-1}(X)\right) \\ &= \text{Image}\left(\partial : H_n(X, X_*) \rightarrow H_{n-1}(X_*)\right), \end{aligned} \quad (5.9a)$$

$$\text{rank } H_{n-1}(X_*) = \text{rank } \mathbb{V}(X_*) + \text{rank } H_{n-1}(X). \quad (5.9b)$$

Let us observe that Lemma 5.10 and the universal coefficients theorem implies that

$$H^n(\hat{X}_+, \hat{X}_*) = \text{Hom}\left(H_n(\hat{X}_+, \hat{X}_*), \mathbb{Z}\right).$$

The Lefschetz hyperplane theorem and the universal coefficients theorem show that

$$H^n(X, X_*) = \text{Hom}_{\mathbb{Z}}\left(H_n(X, X_*), \mathbb{Z}\right).$$

We obtain a commutative cohomological diagram with exact rows:

$$\begin{array}{ccccccc} H^n(\hat{X}_+, \hat{X}_*) & \xleftarrow{\delta} & H^{n-1}(\hat{X}_*) & \xleftarrow{\quad} & H^{n-1}(\hat{X}_+) & \xleftarrow{\quad} & 0 \\ \uparrow \text{mono} & & \uparrow \cong & & \uparrow & & \\ H^n(X, X_*) & \xleftarrow{\delta} & H^{n-1}(X_*) & \xleftarrow{i^*} & H^{n-1}(X) & \xleftarrow{\quad} & 0 \end{array}$$

This diagram shows that

$$\begin{aligned} \mathbb{I}(X_*)^\vee &:= \ker\left(\delta : H^{n-1}(\hat{X}_*) \rightarrow H^n(\hat{X}_+, \hat{X}_*)\right) \\ &\cong \ker\left(\delta : H^{n-1}(X_*) \rightarrow H^n(X, X_*)\right) \\ &\cong \text{Im}\left(i^* : H^{n-1}(X) \rightarrow H^{n-1}(X_*)\right). \end{aligned}$$

Define the module of *invariant cycles* to be the Poincaré dual of  $\mathbb{I}(X_*)^\vee$ ,

$$\mathbb{I}(X_*) := \left\{ u \cap [X_*]; \quad u \in \mathbb{I}(X_*)^\vee \right\} \subset H_{n-1}(X_*),$$

or equivalently,

$$\mathbb{I}(X_*) = \text{Image}\left(i^! : H_{n+1}(X) \rightarrow H_{n-1}(X_*)\right), \quad i^! := PD_{X_*} \circ i^* \circ PD_X^{-1}.$$

The last identification can be loosely interpreted as saying that an invariant cycle is a cycle in a generic fiber  $X_*$  obtained by intersecting  $X_*$  with a cycle on  $X$  of dimension  $\frac{1}{2} \dim_{\mathbb{R}} X = \dim_{\mathbb{C}} X$ . The reason these cycles are called

*invariant* has to do with the monodromy of the Lefschetz fibration and it is elaborated in greater detail in a later section.

Since  $i^*$  is one-to-one on  $H^{n-1}(X)$ , we deduce  $i^!$  is one-to-one, so that

$$\begin{aligned} \text{rank } \mathbb{I}(X_*) &= \text{rank } H_{n+1}(X) = \text{rank } H_{n-1}(X) \\ &= \text{rank } \text{Im} (i_* : H_{n-1}(X_*) \rightarrow H_{n-1}(X)). \end{aligned} \tag{5.10}$$

Using the elementary fact

$$\begin{aligned} \text{rank } H_{n-1}(X_*) &= \text{rank } \ker (H_{n-1}(X_*) \xrightarrow{i_*} H_{n-1}(X)) \\ &\quad + \text{rank } \text{Im} (i_* : H_{n-1}(X_*) \xrightarrow{i_*} H_{n-1}(X)), \end{aligned}$$

we deduce the following result.

**Theorem 5.18 (Weak Lefschetz theorem).** *For every projective manifold  $X \hookrightarrow \mathbb{P}^N$  of complex dimension  $n$  and for a generic hyperplane  $H \subset \mathbb{P}^N$ , the Gysin morphism*

$$i^! : H_{n+1}(X) \rightarrow H_{n-1}(X \cap H)$$

*is injective, and we have*

$$\text{rank } H_{n-1}(X \cap H) = \text{rank } \mathbb{I}(X \cap H) + \text{rank } \mathbb{V}(X \cap H),$$

where

$$\mathbb{V}(X \cap H) = \ker (H_{n-1}(X \cap H) \rightarrow H_{n-1}(X)), \quad \mathbb{I}(X \cap H) = \text{Image } i^!. \quad \square$$

The module of invariant cycles can be given a more geometric description. Using Lemma 5.10, the universal coefficients theorem, and the equality

$$\mathbb{I}(X_*)^\vee = \ker (\delta : H^{n-1}(\hat{X}_*) \rightarrow H^n(\hat{X}_+, \hat{X}_*)),$$

we deduce

$$\mathbb{I}(X_*)^\vee = \left\{ \omega \in H^{n-1}(\hat{X}_*); \langle \omega, v \rangle = 0, \forall v \in \mathbb{V}(X_*) \right\}.$$

Observe that  $n - 1 = \frac{1}{2} \dim \hat{X}_*$  and thus the Kronecker pairing on  $H_{n-1}(X_*)$  is given by the intersection form. This is nondegenerate by Poincaré duality. Thus

$$\mathbb{I}(X_*) := \left\{ y \in H_{n-1}(X_*); y \cdot v = 0, \forall v \in \mathbb{V}(X_*) \right\}. \tag{5.11}$$

We have thus proved the following fact.

**Proposition 5.19.** *A middle dimensional cycle on  $X_*$  is invariant if and only if its intersection number with any vanishing cycle is trivial.*

### 5.3 The Hard Lefschetz Theorem

The last theorem in the previous section is only the tip of the iceberg. In this section we delve deeply into the anatomy of an algebraic manifold and try to understand the roots of the weak Lefschetz theorem.

In this section, unless specified otherwise,  $H_\bullet(X)$  denotes the homology with coefficients in  $\mathbb{R}$ . For every projective manifold  $X \hookrightarrow \mathbb{P}^N$  we denote by  $X'$  its intersection with a generic hyperplane. Define inductively

$$X^{(0)} = X, \quad X^{(q+1)} := (X^{(q)})', \quad q \geq 0.$$

Thus  $X^{(q+1)}$  is a generic hyperplane section of  $X^{(q)}$ .

Denote by  $\omega \in H^2(X)$  the Poincaré dual of the hyperplane section  $X'$ , i.e.

$$[X'] = \omega \cap [X].$$

If a cycle  $c \in H_q(X)$  is represented by a smooth (real) oriented submanifold of dimension  $q$  then its intersection with a generic hyperplane  $H$  is a  $(q-2)$ -cycle in  $X \cap H = X'$ . This intuitive operation  $c \mapsto c \cap H$  is none other than the Gysin map

$$i^! : H_q(X) \rightarrow H_{q-2}(X')$$

related to  $\omega \cap : H_q(X) \rightarrow H_{q-2}(X)$  via the commutative diagram

$$\begin{array}{ccc} H_q(X) & \xrightarrow{i^!} & H_{q-2}(X') \\ & \searrow \omega \cap & \downarrow i_* \\ & & H_{q-2}(X) \end{array}$$

**Proposition 5.20.** *The following statements are equivalent.*

- HL<sub>1</sub>.**  $\mathbb{V}(X') \cap \mathbb{I}(X') = 0$ .
- HL<sub>2</sub>.**  $\mathbb{V}(X') \oplus \mathbb{I}(X') = H_{n-1}(X')$
- HL<sub>3</sub>.** *The restriction of  $i_* : H_{n-1}(X') \rightarrow H_{n-1}(X)$  to  $\mathbb{I}(X')$  is an isomorphism.*
- HL<sub>4</sub>.** *The map  $\omega \cap : H_{n+1}(X) \rightarrow H_{n-1}(X)$  is an isomorphism.*
- HL<sub>5</sub>.** *The restriction of the intersection form on  $H_{n-1}(X')$  to  $\mathbb{V}(X')$  stays non-degenerate.*
- HL<sub>6</sub>.** *The restriction of the intersection form to  $\mathbb{I}(X')$  stays nondegenerate.*

*Proof.* • The weak Lefschetz theorem shows that **HL<sub>1</sub>**  $\iff$  **HL<sub>2</sub>**.

• **HL<sub>2</sub>**  $\implies$  **HL<sub>3</sub>**. From the equality

$$\mathbb{V}(X') = \ker\left(i_* : H_{n-1}(X') \rightarrow H_{n-1}(X)\right)$$

and **HL<sub>2</sub>** we deduce that the restriction of  $i_*$  to  $\mathbb{I}(X')$  is an isomorphism onto the image of  $i_*$ . On the other hand, the Lefschetz hyperplane theorem shows that the image of  $i_*$  is  $H_{n-1}(X)$ .

- **HL<sub>3</sub> ⇒ HL<sub>4</sub>.** Theorem 5.18 shows that  $i^! : H_{n+1}(X) \rightarrow H_{n-1}(X')$  is a monomorphism with image  $\mathbb{I}(X')$ . By **HL<sub>3</sub>**,  $i_* : \mathbb{I}(X') \rightarrow H_{n-1}(X)$  is an isomorphism, and thus  $\omega \cap = i_* \circ i^!$  is an isomorphism.
- **HL<sub>4</sub> ⇒ HL<sub>3</sub>** If  $i_* \circ i^! = \omega \cap : H_{n+1}(X) \rightarrow H_{n-1}(X)$  is an isomorphism then we conclude that  $i_* : \text{Im}(i^!) = \mathbb{I}(X') \rightarrow H_{n-1}(X)$  is onto. Using (5.10) we deduce that  $\dim \mathbb{I}(X') = \dim H_{n-1}(X)$ , so that  $i_* : H_{n-1}(X') \rightarrow H_{n-1}(X)$  must be one-to-one. The Lefschetz hyperplane theorem now implies that  $i_*$  is an isomorphism.
- **HL<sub>2</sub> ⇒ HL<sub>5</sub>, HL<sub>2</sub> ⇒ HL<sub>6</sub>.** This follows from (5.11), which states that  $\mathbb{I}(X')$  is the orthogonal complement of  $\mathbb{V}(X')$  with respect to the intersection form.
- **HL<sub>5</sub> ⇒ HL<sub>1</sub>, HL<sub>6</sub> ⇒ HL<sub>1</sub>.** Suppose we have a cycle

$$c \in \mathbb{V}(X') \cap \mathbb{I}(X').$$

Then

$$c \in \mathbb{I}(X') \implies c \cdot v = 0, \quad \forall v \in \mathbb{V}(X'),$$

while

$$c \in \mathbb{V}(X') \implies c \cdot z = 0, \quad \forall z \in \mathbb{I}(X').$$

When the restriction of the intersection to either  $\mathbb{V}(X')$  or  $\mathbb{I}(X')$  is non-degenerate, the above equalities imply  $c = 0$ , so that  $\mathbb{V}(X') \cap \mathbb{I}(X') = 0$ . □

**Theorem 5.21 (The hard Lefschetz theorem).** *The equivalent statements **HL<sub>1</sub>, . . . , HL<sub>6</sub>** above are true (for the homology with real coefficients).*

This is a highly nontrivial result. Its complete proof requires sophisticated analytical machinery (Hodge theory) and is beyond the scope of this book. We refer the reader to [GH, Section 0.7] for more details. In the remainder of this section we will discuss other topological facets of this remarkable theorem.

We have a decreasing filtration

$$X = X^{(0)} \supset X' \supset X^{(2)} \supset \dots \supset X^{(n)} \supset \emptyset,$$

so that  $\dim_{\mathbb{C}} X^{(q)} = n - q$ , and  $X^{(q)}$  is a generic hyperplane section of  $X^{(q-1)}$ . Denote by  $\mathbb{I}_q(X) \subset H_{n-q}(X^{(q)})$  the module of invariant cycles

$$\mathbb{I}_q(X) = \text{Image} \left( i^! : H_{n-q+2}(X^{(q-1)}) \rightarrow H_{n-q}(X^{(q)}) \right).$$

Its Poincaré dual (in  $X^{(q)}$ ) is

$$\mathbb{I}_q(X)^\vee = \text{Image} \left( i^* : H^{n-q}(X^{(q-1)}) \rightarrow H^{n-q}(X^{(q)}) \right) = PD_{X^{(q)}}^{-1}(\mathbb{I}_q(X)).$$

The Lefschetz hyperplane theorem implies that the morphisms

$$i_* : H_k(X^{(q)}) \rightarrow H_k(X^{(j)}), \quad q \geq j, \tag{5.12}$$



are isomorphisms for  $k < \dim_{\mathbb{C}} X^{(q)} = (n - q)$ . We conclude by duality that

$$i^* : H^k(X^{(j)}) \rightarrow H^k(X^{(q)}), \quad j \leq q,$$

is an isomorphism if  $k + q < n$ .

Using **HL**<sub>3</sub> we deduce that

$$i_* : \mathbb{I}_q(X) \rightarrow H_{n-q}(X^{(q-1)})$$

is an isomorphism. Using the Lefschetz hyperplane section isomorphisms in (5.12), we conclude that

$$i_* \text{ maps } \mathbb{I}_q(X) \text{ isomorphically onto } H_{n-q}(X). \quad (\dagger)$$

Using the equality

$$\mathbb{I}_q(X)^\vee = \text{Image} (i^* : H^{n-q}(X^{(q-1)}) \rightarrow H^{n-1}(X^{(q)}))$$

and the Lefschetz hyperplane theorem we obtain the isomorphisms

$$H^{n-q}(X) \xrightarrow{i^*} H^{n-q}(X') \xrightarrow{i^*} \dots \xrightarrow{i^*} H^{n-q}(X^{(q-1)}).$$

Using Poincaré duality we obtain

$$i^! \text{ maps } H_{n+q}(X) \text{ isomorphically onto } \mathbb{I}_q(X). \quad (\dagger\dagger)$$

Iterating **HL**<sub>6</sub> we obtain

$$\begin{aligned} & \text{The restriction of the intersection form of } H_{n-q}(X) \text{ to } \mathbb{I}_q(X) \\ & \text{is nondegenerate.} \end{aligned} \quad (\dagger\dagger\dagger)$$

The isomorphism  $i_*$  carries the intersection form on  $\mathbb{I}_q(X)$  to a nondegenerate form on  $H_{n-q}(X) \cong H_{n+q}(X)$ . When  $n - q$  is odd this is a skew-symmetric form, and thus the nondegeneracy assumption implies

$$\dim H_{n-q}(X) = \dim H_{n+q}(X) \in 2\mathbb{Z}.$$

We have thus proved the following result.

**Corollary 5.22.** *The odd dimensional Betti numbers  $b_{2k+1}(X)$  of  $X$  are even.* □

*Remark 5.23.* The above corollary shows that not all even dimensional manifolds are algebraic. Take for example  $X = S^3 \times S^1$ . Using Künneth's formula we deduce

$$b_1(X) = 1.$$

This manifold is remarkable because it admits a complex structure, yet it is not algebraic! As a complex manifold it is known as the *Hopf surface* (see [Ch, Chapter 1]). □

The  $q$ th exterior power  $\omega^q$  is Poincaré dual to the fundamental class

$$[X^{(q)}] \in H_{2n-2q}(X)$$

of  $X^{(q)}$ . Therefore we have the factorization

$$\begin{array}{ccc} H_k(X) & \xrightarrow{i^!} & H_{k-2q}(X^{(q)}) \\ & \searrow \omega^q \cap & \downarrow i_* \\ & & H_{k-2q}(X) \end{array}$$

Using (††) and (†) we obtain the following generalization of **HL**<sub>4</sub>.

**Corollary 5.24.** *For  $q = 1, 2, \dots, n$  the map*

$$\omega^q \cap : H_{n+q}(X) \rightarrow H_{n-q}(X)$$

*is an isomorphism.* □

Clearly, the above corollary is equivalent to the *hard Lefschetz theorem*. In fact, we can formulate an even more refined version.

**Definition 5.25.** (a) *An element  $c \in H_{n+q}(X)$ ,  $0 \leq q \leq n$ , is called primitive if*

$$\omega^{q+1} \cap c = 0.$$

*We will denote by  $P_{n+q}(X)$  the subspace of  $H_{n+q}(X)$  consisting of primitive elements.*

(b) *An element  $z \in H_{n-q}(X)$  is called effective if*

$$\omega \cap z = 0.$$

*We will denote by  $E_{n-q}(X)$  the subspace of effective elements.* □

Observe that

$$c \in H_{n+q}(X) \text{ is primitive} \iff \omega^q \cap c \in H_{n-q}(X) \text{ is effective.}$$

Roughly speaking, a cycle is effective if it does not intersect the “part at infinity of  $X$ ”,  $X \cap$  hyperplane.

**Theorem 5.26 (Lefschetz decomposition).** (a) *Every element  $c \in H_{n+q}(X)$  decomposes uniquely as*

$$c = c_0 + \omega \cap c_1 + \omega^2 \cap c_2 + \dots, \tag{5.13}$$

*where  $c_j \in H_{n+q+2j}(X)$  are primitive elements.*

(b) *Every element  $z \in H_{n-q}(X)$  decomposes uniquely as*

$$z = \omega^q \cap z_0 + \omega^{q+1} \cap z_1 + \dots, \tag{5.14}$$

*where  $z_j \in H_{n+q+2j}(X)$  are primitive elements.*

*Proof.* Observe that because the above representations are unique and since

$$(5.14) = \omega^q \cap (5.13),$$

we deduce that Corollary 5.24 is a consequence of the Lefschetz decomposition.

Conversely, let us show that (5.13) is a consequence of Corollary 5.24. We will use a descending induction starting with  $q = n$ .

A dimension count shows that

$$P_{2n}(X) = H_{2n}(X), \quad P_{2n-1}(X) = H_{2n-1}(X),$$

and (5.13) is trivially true for  $q = n, n - 1$ . The identity

$$\alpha \cap (\beta \cap c) = (\alpha \cup \beta) \cap c, \quad \forall \alpha, \beta \in H^\bullet(X), \quad c \in H_\bullet(X),$$

shows that for the induction step it suffices to prove that every element  $c \in H_{n+q}(X)$  can be written uniquely as

$$c = c_0 + \omega \cap c_1, \quad c_1 \in H_{n+q+2}(X), \quad c_0 \in P_{n+q}(X).$$

According to Corollary 5.24 there exists a unique  $z \in H_{n+q+2}(X)$  such that

$$\omega^{q+2} \cap z = \omega^{q+1} \cap c,$$

so that

$$c_0 := c - \omega \cap z \in P_{n+q}(X).$$

To prove the uniqueness of the decomposition assume

$$0 = c_0 + \omega \cap c_1, \quad c_0 \in P_{n+q}(X).$$

Then

$$0 = \omega^{q+1} \cap (c_0 + \omega \cap c_1) \implies \omega^{q+2} \cap c_1 = 0 \implies c_1 = 0 \implies c_0 = 0. \quad \square$$

The Lefschetz decomposition shows that the homology of  $X$  is completely determined by its primitive part. Moreover, the above proof shows that

$$0 \leq \dim P_{n+q} = b_{n+q} - b_{n+q+2} = b_{n-q} - b_{n-q-2},$$

which implies the *unimodality* of the Betti numbers of an algebraic manifold,

$$1 = b_0 \leq b_2 \leq \cdots \leq b_{2\lfloor n/2 \rfloor}, \quad b_1 \leq b_3 \leq \cdots \leq b_{2\lfloor (n-1)/2 \rfloor + 1},$$

where  $\lfloor x \rfloor$  denotes the integer part of  $x$ . These inequalities introduce additional topological restrictions on algebraic manifolds. For example, the sphere  $S^4$  cannot be an algebraic manifold because  $b_2(S^4) = 0 < b_0(S^4) = 1$ .

### 5.4 Vanishing Cycles and Local Monodromy

In this section we finally give the promised proof of Lemma 5.10.

Recall we are given a Morse function  $\hat{f} : \hat{X} \rightarrow \mathbb{P}^1$  and its critical values  $t_1, \dots, t_r$  are all located in the upper closed hemisphere  $D_+$ . We denote the corresponding critical points by  $p_1, \dots, p_r$ , so that

$$\hat{f}(p_j) = t_j, \quad \forall j.$$

We will identify  $D_+$  with the unit closed disk at  $0 \in \mathbb{C}$ . Let  $j = 1, \dots, r$ .

- Denote by  $D_j$  a *closed* disk of very small radius  $\rho$  centered at  $t_j \in D_+$ . If  $\rho \ll 1$  these disks are disjoint.
- Connect  $*$   $\in \partial D_+$  to  $t_j + \rho \in \partial D_j$  by a smooth path  $\ell_j$  such that the resulting paths  $\ell_1, \dots, \ell_r$  are disjoint (see Figure 5.2). Set  $\mathbf{k}_j := \ell_j \cup D_j$ ,  $\ell = \bigcup \ell_j$  and  $\mathbf{k} = \bigcup \mathbf{k}_j$ .
- Denote by  $B_j$  a small *closed* ball of radius  $R$  in  $\hat{X}$  centered at  $p_j$ .

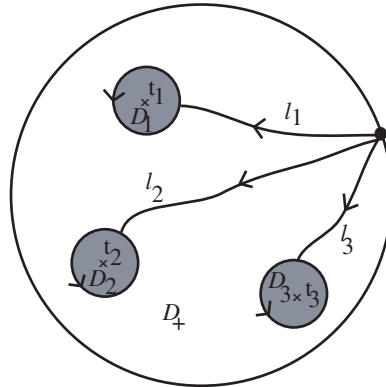

Fig. 5.2. Isolating the critical values.

The proof of Lemma 5.10 will be carried out in several steps.

**Step 1.** *Localizing around the singular fibers.* Set

$$L := f^{-1}(\ell), \quad K := \hat{f}^{-1}(\mathbf{k}).$$

We will show that  $\hat{X}_*$  is a deformation retract of  $L$ , and  $K$  is a deformation retract of  $\hat{X}_+$ , so that the inclusions

$$(\hat{X}_+, \hat{X}_*) \hookrightarrow (\hat{X}_+, L) \hookrightarrow (K, L)$$

induce isomorphisms of all homology (and homotopy) groups.

Observe that  $k$  is a strong deformation retract of  $D_+$  and  $*$  is a strong deformation retract of  $\ell$ . Using the Ehresmann fibration theorem we deduce that we have fibrations

$$f : L \rightarrow \ell, \quad \hat{f} : \hat{X}_+ \setminus \hat{f}^{-1}\{t_1, \dots, t_r\} \rightarrow D_+ \setminus \{t_1, \dots, t_r\}.$$

Using the homotopy lifting property of fibrations (see [Ha, Section 4.3]) we obtain strong deformation retractions

$$L \rightarrow \hat{X}_*, \quad \hat{X}_+ \setminus \hat{f}^{-1}\{t_1, \dots, t_r\} \rightarrow K \setminus \hat{f}^{-1}\{t_1, \dots, t_r\}.$$

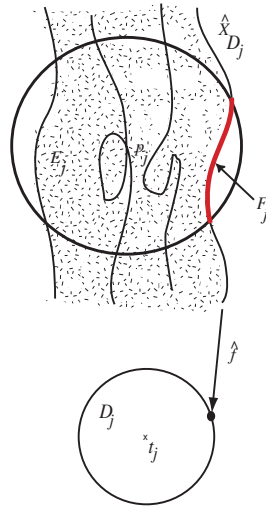

Fig. 5.3. Isolating the critical points.

**Step 2.** *Localizing near the critical points.* Set (see Figure 5.3)

$$\begin{aligned} \hat{X}_{D_j} &:= \hat{f}^{-1}(D_j), \quad \hat{X}_j := f^{-1}(t_j + \rho), \\ E_j &:= \hat{X}_{D_j} \cap B_j, \quad F_j := \hat{X}_j \cap B_j, \\ E &:= \cup_j E_j, \quad F := \cup_j F_j. \end{aligned}$$

The excision theorem shows that the inclusions  $(\hat{X}_{D_j}, \hat{X}_j) \rightarrow (K, L)$  induce an isomorphism

$$\bigoplus_{j=1}^r H_\bullet(\hat{X}_{D_j}, \hat{X}_j) \rightarrow H_\bullet(K, L) \cong H_\bullet(\hat{X}_+, \hat{X}_*).$$

Now define

$$Y_j := \hat{X}_{D_j} \setminus \text{int}(B_j), \quad Z_j := F_j \setminus \text{int}(B_j).$$

The map  $\hat{f}$  induces a surjective submersion  $\hat{f} : Y_j \rightarrow D_j$ , and by the Ehresmann fibration theorem it defines a trivial fibration with fiber  $Z_j$ . In particular,  $Z_j$  is a deformation retract of  $Y_j$ , and thus  $\hat{X}_j = F_j \cup Z_j$  is a deformation retract of  $F_j \cup Y_j$ . We deduce

$$H_\bullet(\hat{X}_{D_j}, \hat{X}_j) \cong H_\bullet(\hat{X}_{D_j}, F_j \cup Y_j) \cong H_\bullet(E_j, F_j),$$

where the last isomorphism is obtained by excising  $Y_j$ .

**Step 3. Conclusion.** We will show that for every  $j = 1, \dots, r$  we have

$$H_q(E_j, F_j) = \begin{cases} 0 & \text{if } q \neq \dim_{\mathbb{C}} X = n \\ \mathbb{Z} & \text{if } q = n. \end{cases}$$

At this point we need to use the nondegeneracy of  $p_j$ . To simplify the presentation, in the sequel we will drop the subscript  $j$ .

By making  $B$  even smaller we can assume that there exist holomorphic coordinates  $(z_k)$  on  $B$ , and  $u$  near  $\hat{f}(p)$ , such that  $\hat{f}$  is described in these coordinates by  $z_1^2 + \dots + z_n^2$ . Then  $E$  and  $F$  can be given the explicit descriptions

$$\begin{aligned} E &= \left\{ \mathbf{z} = (z_1, \dots, z_n); \sum_i |z_i|^2 \leq r^2, \left| \sum_i z_i^2 \right| < \rho \right\}, \\ F &= F_\rho := \left\{ \mathbf{z} \in E; \sum_i z_i^2 = \rho \right\}. \end{aligned} \tag{5.15}$$

The region  $E$  can be contracted to the origin because  $\mathbf{z} \in E \implies t\mathbf{z} \in E, \forall t \in [0, 1]$ . This shows that the connecting homomorphism  $H_q(E, F) \rightarrow H_{q-1}(F)$  is an isomorphism for  $q \neq 0$ . Moreover,  $H_0(E, F) = 0$ . Lemma 5.10 is now a consequence of the following result.

**Lemma 5.27.**  $F_\rho$  is diffeomorphic to the disk bundle of the tangent bundle  $TS^{n-1}$ .

*Proof.* Set

$$\begin{aligned} z_j &:= x_j + iy_j, \quad \mathbf{x} := (x_1, \dots, x_n), \quad \mathbf{y} := (y_1, \dots, y_n), \\ |\mathbf{x}|^2 &:= \sum_j x_j^2, \quad |\mathbf{y}|^2 := \sum_j y_j^2. \end{aligned}$$

The fiber  $F$  has the description

$$|\mathbf{x}|^2 = \rho + |\mathbf{y}|^2, \quad \mathbf{x} \cdot \mathbf{y} = 0 \in \mathbb{R}, \quad |\mathbf{x}|^2 + |\mathbf{y}|^2 \leq r^2.$$

In particular,

$$2|\mathbf{y}|^2 \leq r^2 - \rho.$$

Now let

$$\mathbf{u} := (\rho + |\mathbf{v}|^2)^{-1/2} \mathbf{x} \in \mathbb{R}^n, \quad \mathbf{v} = \frac{2}{r^2 - \rho} \mathbf{y}.$$

In the coordinates  $\mathbf{u}, \mathbf{v}$  the fiber  $F$  has the description

$$|\mathbf{u}|^2 = 1, \quad \mathbf{u} \cdot \mathbf{v} = 0, \quad |\mathbf{v}|^2 \leq 1.$$

The first equality describes the unit sphere  $S^{n-1} \subset \mathbb{R}^n$ . Observe next that

$$\mathbf{u} \cdot \mathbf{v} \iff \mathbf{y} \perp \mathbf{u}$$

shows that  $\mathbf{v}$  is tangent to  $S^{n-1}$  at  $\mathbf{u}$ . It is now obvious that  $F$  is the disk bundle of  $TS^{n-1}$ . This completes the proof of Lemma 5.10.  $\square$

We want to analyze in greater detail the picture emerging from the proof of Lemma 5.27. Denote by  $B$  a small closed ball centered at  $0 \in \mathbb{C}^n$  and consider

$$f : B \rightarrow \mathbb{C}, \quad f(z) = z_1^2 + \cdots + z_n^2.$$

Let  $\rho$  be a positive and very small real number.

We have seen that the regular fiber  $F_\rho = f^{-1}(\rho)$  ( $0 < \rho \ll 1$ ) is diffeomorphic to a disk bundle over an  $(n - 1)$ -sphere  $S_\rho$  of radius  $\sqrt{\rho}$ . This sphere is defined by the equation

$$S_\rho := \{\mathbf{Im} \mathbf{z} = 0\} \cap f^{-1}(\rho) \iff \{\mathbf{y} = 0, \quad |\mathbf{x}|^2 = \rho\}.$$

As  $\rho \rightarrow 0$ , i.e., we are looking at fibers closer and closer to the singular one  $F_0 = f^{-1}(0)$ , the radius of this sphere goes to zero, while for  $\rho = 0$  the fiber is locally the cone  $z_1^2 + \cdots + z_n^2 = 0$ . We say that  $S_\rho$  is a *vanishing sphere*.

The homology class in  $F_\rho$  determined by an orientation on this vanishing sphere generates  $H_{n-1}(F_\rho)$ . Such a homology class was called *vanishing cycle* by Lefschetz. We will denote by  $\Delta$  a homology class obtained in this fashion, i.e., from a vanishing sphere and an orientation on it (see Figure 5.4). The proof of Lemma 5.10 shows that Lefschetz's vanishing cycles coincide with what we previously named vanishing cycles.

Observe now that since  $\partial : H_n(B, F) \rightarrow H_{n-1}(F)$  is an isomorphism, there exists a relative  $n$ -cycle  $Z \in H_n(B, F)$  such that  $\partial Z = \Delta$ . The relative cycle  $Z$  is known as the *thimble* associated with the vanishing cycle  $\Delta$ . It is filled in by the family  $(S_\rho)$  of shrinking spheres. In Figure 5.4 it is represented by the shaded disk.

Denote by  $D_\rho \subset \mathbb{C}$  the closed disk of radius  $\rho$  centered at the origin and by  $B_r \subset \mathbb{C}^n$  the closed ball of radius  $r$  centered at the origin. Set

$$E_{r,\rho} := \{\mathbf{z} \in B_r; \quad f(z) \in D_\rho\}, \quad E_{r,\rho}^* := \{\mathbf{z} \in B_r; \quad 0 < |f(z)| < \rho\},$$

$$\partial E_{r,\rho} := \{\mathbf{z} \in \partial B_r; \quad f(z) \in D_\rho\}.$$

We will use the following technical result, whose proof is left to the reader.

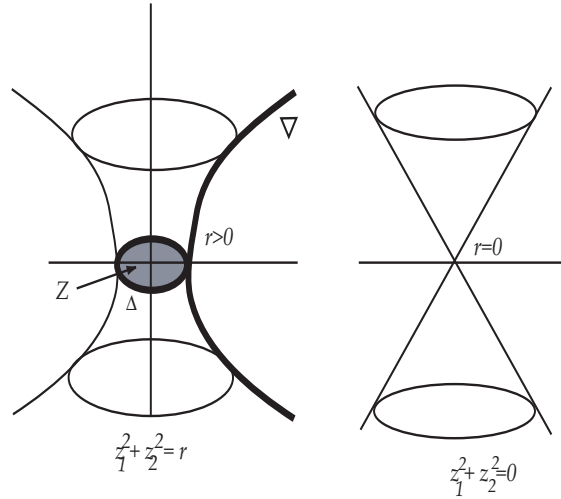

Fig. 5.4. The vanishing cycle for functions of  $n = 2$  variables.

**Lemma 5.28.** For any  $\rho, r > 0$  such that  $r^2 > \rho$  the maps

$$f : E_{r,\rho}^* \rightarrow D_\rho \setminus \{0\} =: D_\rho^*, \quad f_\partial : \partial E_{r,\rho} \rightarrow D_\rho$$

are proper surjective submersions. □

By rescaling we can assume  $1 < \rho < 2 = r$ . Set  $B = B_r, D = D_\rho$ , etc. According to the Ehresmann fibration theorem we have two locally trivial fibrations.

- $F \hookrightarrow E^* \twoheadrightarrow D^*$  with standard fiber the manifold with boundary

$$F \cong f^{-1}(*) \cap \bar{B}.$$

- $\partial F \hookrightarrow \partial E \twoheadrightarrow D$  with standard fiber  $\partial F \cong f^{-1}(*) \cap \partial \bar{B}$ . The bundle  $\partial E \rightarrow D$  is a globally trivializable bundle because its base is contractible.

Choose the basepoint  $* = 1$ . From the proof of Lemma 5.27 we have

$$F = f^{-1}(*) = \{ \mathbf{z} = \mathbf{x} + i\mathbf{y} \in \mathbb{C}^n; |\mathbf{x}|^2 + |\mathbf{y}|^2 \leq 4, |\mathbf{x}|^2 = 1 + |\mathbf{y}|^2, \mathbf{x} \cdot \mathbf{y} = 0 \}.$$

Denote by  $\mathbb{M}$  the standard model for the fiber, incarnated as the unit disk bundle determined by the tangent bundle of the unit sphere  $S^{n-1} \hookrightarrow \mathbb{R}^n$ . The standard model  $\mathbb{M}$  has the algebraic description

$$\mathbb{M} = \left\{ (\mathbf{u}, \mathbf{v}) \in \mathbb{R}^n \times \mathbb{R}^n; |\mathbf{u}| = 1, \mathbf{u} \cdot \mathbf{v} = 0, |\mathbf{v}| \leq 1 \right\}.$$

Note that



$$\partial\mathbb{M} = \left\{ (\mathbf{u}, \mathbf{v}) \in \mathbb{R}^n \times \mathbb{R}^n; |\mathbf{u}| = 1 = |\mathbf{v}|, \mathbf{u} \cdot \mathbf{v} = 0 \right\}.$$

We have a diffeomorphism

$$\begin{aligned} \Phi : F \rightarrow \mathbb{M}, \quad F \ni \mathbf{z} = \mathbf{x} + i\mathbf{y}, \mapsto \begin{cases} \mathbf{u} = (1 + |\mathbf{y}|^2)^{-1/2} \cdot \mathbf{x} \\ \mathbf{v} = \alpha\mathbf{y}, \end{cases} & (\Phi) \\ \alpha = \sqrt{2/3}. \end{aligned}$$

Its inverse is given by

$$\mathbb{M} \ni (\mathbf{u}, \mathbf{v}) \xrightarrow{\Phi^{-1}} \begin{cases} \mathbf{x} = (1 + |\mathbf{v}|^2/\alpha^2)^{1/2}\mathbf{u}, \\ \mathbf{y} = \alpha^{-1}\mathbf{v}. \end{cases} \quad (\Phi^{-1})$$

This diffeomorphism  $\Phi$  maps the vanishing sphere  $\Sigma = \{\operatorname{Im} \mathbf{z} = 0\} \subset F$  to the sphere

$$\mathbb{S} := \left\{ (\mathbf{u}, \mathbf{v}) \in \mathbb{R}^n \times \mathbb{R}^n; |\mathbf{u}| = 1, \mathbf{v} = 0 \right\}.$$

We will say that  $\mathbb{S}$  is the *standard model* for the vanishing cycle. The *standard model* for the thimble is the ball  $\{|\mathbf{u}| \leq 1\}$  bounding  $\mathbb{S}$ .

Fix a trivialization  $\partial E \xrightarrow{\cong} \partial F \times D$  and a metric  $h$  on  $\partial F$ . We now equip  $\partial E$  with the product metric  $g_\partial := h \oplus h_0$ , where  $h_0$  denotes the Euclidean metric on  $D$ . Now extend  $g_\partial$  to a metric on  $E$  and denote by  $H$  the subbundle of  $TE^*$  consisting of tangent vectors  $g$ -orthogonal to the fibers of  $f$ . The differential  $f_*$  produces isomorphisms

$$f_* : H_p \rightarrow T_{f(p)}D^*, \quad \forall p \in E^*.$$

Suppose  $\gamma : [0, 1] \rightarrow D^*$  is a smooth path beginning and ending at  $*$ ,  $\gamma(0) = \gamma(1) = *$ . We obtain for each  $p \in F = f^{-1}(*)$  a smooth path  $\tilde{\gamma}_p : [0, 1] \rightarrow E$  that is tangent to the horizontal sub-bundle  $H$ , and it is a lift of  $w$  starting at  $p$ , i.e., the diagram below is commutative:

$$\begin{array}{ccc} & & (E^*, p) \\ & \nearrow \tilde{\gamma}_p & \downarrow f \\ ([0, 1], 0) & \xrightarrow{\gamma} & (D^*, *) \end{array}$$

We get in this fashion a map  $h_\gamma : F = f^{-1}(*) \rightarrow f^{-1}(*)$ ,  $p \mapsto \tilde{\gamma}_p(*)$ .

The standard results on the smooth dependence of solutions of ODEs on initial data show that  $h_\gamma$  is a smooth map. It is in fact a diffeomorphism of  $F$  with the property that

$$h_\gamma |_{\partial F} = \mathbb{1}_{\partial F}.$$

The map  $h_\gamma$  is not canonical, because it depends on several choices: the choice of trivialization  $\partial E \cong \partial F \times D$ , the choice of metric  $h$  on  $F$ , and the choice of the extension  $g$  of  $g_\partial$ .

We say that two diffeomorphisms  $G_0, G_1 : F \rightarrow F$  such that  $G_i|_{\partial F} = \mathbb{1}_{\partial F}$  are *isotopic* if there exists a smooth homotopy

$$G : [0, 1] \times F \rightarrow F$$

connecting them such that for each  $t$  the map  $G_t = G(t, \bullet) : F \rightarrow F$  is a diffeomorphism satisfying  $G_t|_{\partial F} = \mathbb{1}_{\partial F}$  for all  $t \in [0, 1]$ .

The isotopy class of  $h_\gamma : F \rightarrow F$  is independent of the various choices listed above, and in fact depends only on the image of  $\gamma$  in  $\pi_1(D^*, *)$ . The induced map

$$[h_\gamma] : H_\bullet(F) \rightarrow H_\bullet(F)$$

is called the (*homological*) *monodromy along the loop*  $\gamma$ . The correspondence

$$[h] : \pi_1(D^*, *) \ni \gamma \mapsto h_\gamma \in \text{Aut}(H_\bullet(F))$$

is a group morphism called *the local (homological) monodromy*.

Since  $h_\gamma|_{\partial F} = \mathbb{1}_{\partial F}$ , we obtain another morphism

$$[h]^{rel} : \pi_1(D^*, *) \rightarrow \text{Aut}(H_\bullet(F, \partial F)),$$

which we will call *local relative monodromy*.

Observe that if  $z$  is a singular  $n$ -chain in  $F$  such that  $\partial z \in \partial F$  (hence  $z$  defines an element  $[z] \in H_n(F, \partial F)$ ), then for every  $\gamma \in \pi_1(D^*, *)$  we have

$$\partial z = \partial h_\gamma z \implies \partial(z - h_\gamma z) = 0,$$

so that the singular chain  $(z - h_\gamma z)$  is a cycle in  $F$ . In this fashion we obtain a *linear* map

$$\mathbf{var} : \pi_1(D^*, *) \rightarrow \text{Hom}(H_{n-1}(F, \partial F) \rightarrow H_{n-1}(F)),$$

$$\mathbf{var}_\gamma(z) = [h_\gamma]^{rel} z - z, \quad z \in H_{n-1}(F, \partial F), \quad \gamma \in \pi_1(D^*, *),$$

called the *variation map*.

The local Picard–Lefschetz formula will provide an explicit description of this variation map. To formulate it we need to make a topological digression.

An orientation  $\mathbf{or} = \mathbf{or}_F$  on  $F$  defines a *nondegenerate* intersection pairing

$$*\mathbf{or} : H_{n-1}(F, \partial F) \times H_{n-1}(F) \rightarrow \mathbb{Z}$$

formally defined by the equality

$$c_1 *\mathbf{or} c_2 = \langle PD_{\mathbf{or}}^{-1}(i_*(c_1)), c_2 \rangle,$$

where  $i_* : H_{n-1}(F) \rightarrow H_{n-1}(F, \partial F)$  is the inclusion induced morphism,

$$PD_{\mathbf{or}} : H^{n-1}(F) \rightarrow H_{n-1}(F, \partial F), \quad u \mapsto u \cap [F, \partial F],$$

is the Poincaré–Lefschetz duality defined by the orientation  $\mathbf{or}$ , and  $\langle -, - \rangle$  is the Kronecker pairing.

The group  $H_{n-1}(F, \partial F)$  is an infinite cyclic group. Since  $F$  is the unit disk bundle in the tangent bundle  $T\Sigma$ , a generator of  $H_{n-1}(F, \partial F)$  can be represented by a disk  $\nabla$  in this disk bundle (see Figure 5.5). The generator is fixed by a choice of orientation on  $\nabla$ . Thus  $\mathbf{var}_\gamma$  is completely understood once we understand its action on  $\nabla$  (see Figure 5.5).

The group  $H_{n-1}(F)$  is also an infinite cyclic group. It has two generators. Each of them is represented by an embedded  $(n - 1)$ -sphere  $\Sigma$  equipped with one of the two possible orientations. We can thus write

$$\mathbf{var}_\gamma([\nabla]) = \nu_\gamma(\nabla)[\Sigma], \quad \nu(\nabla) = \nu_\gamma([\nabla, \mathbf{or}_\nabla]) \in \mathbb{Z}.$$

The integer  $\nu_\gamma([\nabla])$  is completely determined by the *Picard–Lefschetz number*,

$$m_\gamma(\mathbf{or}_F) := [\nabla] *_{\mathbf{or}_F} \mathbf{var}_\gamma([\nabla]) = \nu_\gamma([\nabla])[\nabla] * [\Sigma].$$

Hence

$$\mathbf{var}_\gamma([\nabla]) = m_\gamma(\mathbf{or}_F)(\nabla *_{\mathbf{or}_F} [\Sigma]) [\Sigma] = \underbrace{([\nabla] * [\Sigma])(\nabla * \mathbf{var}_\gamma(\nabla))}_{\nu_\gamma([\nabla])} [\Sigma],$$

$$\mathbf{var}_\gamma(z) = m_\gamma(\mathbf{or}_F)(z *_{\mathbf{or}_F} [\Sigma]) [\Sigma].$$

The integer  $m_\gamma$  depends on choices of orientations on  $\mathbf{or}_F$ ,  $\mathbf{or}_\nabla$ , and  $\mathbf{or}_\Sigma$  on  $F$ ,  $\nabla$  and  $\Sigma$ , but  $\nu_\gamma$  depends only on the orientations on  $\nabla$  and  $\Sigma$ . Let us explain how to fix such orientations.

The diffeomorphism  $\Phi$  maps the vanishing sphere  $\Sigma \subset F$  to the sphere  $\mathbb{S}$  described in the  $(\mathbf{u}, \mathbf{v})$  coordinates by  $\mathbf{v} = 0, |\mathbf{u}| = 1$ . This is oriented as the

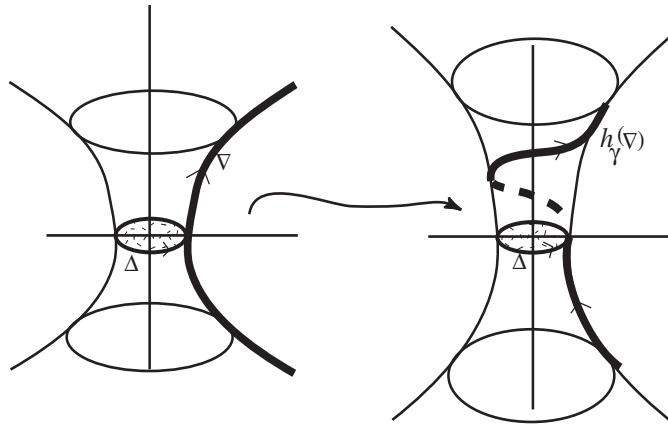

Fig. 5.5. The effect of monodromy on  $\nabla$ .

boundary of the unit disk  $\{|\mathbf{u}| \leq 1\}$  via the outer-normal-first convention.<sup>4</sup> We denote by  $\Delta \in H_{n-1}(F)$  the cycle determined by  $\mathbb{S}$  with this orientation.

Let

$$\mathbf{u}_\pm = (\pm 1, 0, \dots, 0), \quad P_\pm = (\mathbf{u}_\pm, \mathbf{0}) \in \mathbb{S} \subset \mathbb{M}. \quad (5.16)$$

The standard model  $\mathbb{M}$  admits a natural orientation as the total space of a fibration, where we use the fiber-first convention

$$\mathbf{or}(\text{total space}) = \mathbf{or}(\text{fiber}) \wedge \mathbf{or}(\text{base}).$$

Observe that since  $\mathbb{M}$  is (essentially) the tangent bundle of  $\mathbb{S}$ , an orientation on  $\mathbb{S}$  determines tautologically an orientation in each fiber of  $\mathbb{M}$ . Thus the orientation on  $\mathbb{S}$  as boundary of an Euclidean ball determines via the above formula an orientation on  $\mathbb{M}$ . We will refer to this orientation as the *bundle orientation*.<sup>5</sup>

Near  $P_+ \in \mathbb{M}$  we can use as local coordinates the pair

$$(\boldsymbol{\xi}, \boldsymbol{\eta}), \quad \boldsymbol{\xi} = (u_2, \dots, u_n), \quad \boldsymbol{\eta} = (v_2, \dots, v_n). \quad (5.17)$$

The orientation of  $\mathbb{S}$  at  $P_+$  is given by

$$d\boldsymbol{\xi} := du_2 \wedge \dots \wedge du_n,$$

so that the orientation of  $\Sigma$  at  $\Phi^{-1}(P_+)$  is given by  $dx_2 \wedge \dots \wedge dx_n$ . The bundle orientation of  $\mathbb{M}$  is described in these coordinates near  $P_+$  by the form

$$\begin{aligned} \mathbf{or}_{\text{bundle}} &\sim d\boldsymbol{\eta} \wedge d\boldsymbol{\xi} = dv_2 \wedge \dots \wedge dv_n \wedge du_2 \wedge \dots \wedge du_n \\ &\xleftarrow{\Phi} dy_2 \wedge \dots \wedge dy_n \wedge dx_2 \wedge \dots \wedge dx_n. \end{aligned}$$

Using the identification  $(\Phi)$  between  $F$  and  $\mathbb{M}$  we deduce that we can represent  $\nabla$  as the fiber  $\mathbb{T}_+$  of  $\mathbb{M} \rightarrow \mathbb{S}$  over the north pole  $P_+$  (defined in (5.16)) equipped with some orientation. We choose this orientation by regarding  $\mathbb{T}_+$  as the tangent space to  $\mathbb{S}$  at  $P_+$ . More concretely, the orientation on  $\mathbb{T}_+$  is given by

$$\mathbf{or}_{\mathbb{T}_+} \sim dv_2 \wedge \dots \wedge dv_n \xleftarrow{\Phi} dy_2 \wedge \dots \wedge dy_n.$$

We denote by  $\nabla \in H_{n-1}(F, \partial F)$  the cycle determined by  $\mathbb{T}_+$  with the above orientation.

On the other hand,  $F$  has a natural orientation as a complex manifold. We will refer to it as the *complex orientation*. The collection  $(z_2, \dots, z_n)$  defines holomorphic local coordinates on  $F$  near  $\Phi^{-1}(P_+)$ , so that

<sup>4</sup> The orientation of the disk is determined by a linear ordering of the variables  $u_1, \dots, u_n$ .

<sup>5</sup> Note that while in the definition of the bundle orientation we tacitly used a linear ordering of the variables  $u_i$ , the bundle orientation itself is independent of such a choice.

$$\mathbf{or}_{\text{complex}} = dx_2 \wedge dy_2 \wedge \cdots \wedge dx_n \wedge dy_n.$$

We see that<sup>6</sup>

$$\mathbf{or}_{\text{complex}} = (-1)^{n(n-1)/2} \mathbf{or}_{\text{bundle}}.$$

We denote by  $\circ$  (respectively  $*$ ) the intersection number in  $H_{n-1}(F)$  with respect to the bundle (respectively complex) orientation. Then<sup>7</sup>

$$1 = \nabla \circ \Delta = (-1)^{n(n-1)/2} \nabla * \Delta$$

and

$$\begin{aligned} \Delta \circ \Delta &= (-1)^{n(n-1)/2} \Delta * \Delta = \mathbf{e}(TS^{n-1})[S^{n-1}] \\ &= \chi(S^{n-1}) = \begin{cases} 0 & \text{if } n \text{ is even,} \\ 2 & \text{if } n \text{ is odd.} \end{cases} \end{aligned} \tag{5.18}$$

Above,  $\mathbf{e}$  denotes the Euler class of  $TS^{n-1}$ .

The loop  $\gamma_1 : [0, 1] \ni t \mapsto \gamma_1(t) = e^{2\pi it} \in \mathbb{D}^*$  generates the fundamental group of  $D^*$ , and thus the variation map is completely understood once we understand the morphism of  $\mathbb{Z}$ -modules

$$\mathbf{var}_1 := \mathbf{var}_{\gamma_1} : H_{n-1}(F, \partial F) \rightarrow H_{n-1}(F).$$

Once an orientation  $\mathbf{or}_F$  on  $F$  is chosen, we have a Poincaré duality isomorphism

$$H_{n-1}(F) \cong \text{Hom}_{\mathbb{Z}}(H_{n-1}(F, \partial F), \mathbb{Z}),$$

and the morphism  $\mathbf{var}_1$  is completely determined by the *Picard–Lefschetz number*

$$m_1(\mathbf{or}_F) := \nabla *_{\mathbf{or}_F} \mathbf{var}_1(\nabla).$$

We have the following fundamental result.

**Theorem 5.29 (Local Picard–Lefschetz formula).**

$$\begin{aligned} m_1(\mathbf{or}_{\text{bundle}}) &= \nabla \circ \mathbf{var}_1(\nabla) = (-1)^n, \\ m_1(\mathbf{or}_{\text{complex}}) &= \nabla * \mathbf{var}_1(\nabla) = (-1)^{n(n+1)/2}, \\ \mathbf{var}_1(\nabla) &= (-1)^n \Delta, \end{aligned}$$

and

$$\mathbf{var}_1(z) = (-1)^n (z \circ \Sigma) \Sigma = (-1)^{n(n+1)/2} (z * \Sigma) \Sigma, \quad \forall z \in H_{n-1}(F, \partial F).$$

<sup>6</sup> This sign is different from the one in [AGV2] due to our use of the fiber-first convention. This affects the appearance of the Picard-Lefschetz formulæ. The fiber-first convention is employed in [Lam] as well.

<sup>7</sup> The choices of  $\Delta$  and  $\nabla$  depended on linear orderings of the variables  $u_i$ . However, the intersection number  $\nabla \circ \Delta$  is *independent* of such choices.

### 5.5 Proof of the Picard–Lefschetz formula

The following proof of the local Picard–Lefschetz formula is inspired from [HZ] and consists of a three-step reduction process.

We start by constructing an explicit trivialization of the fibration  $\partial E \rightarrow D$ . Set

$$E_w := f^{-1}(w) \cap \bar{B}, \quad 0 \leq |w| < \rho, \quad F = E_{w=1}.$$

Note that

$$\partial E_{a+ib} = \left\{ \mathbf{x} + i\mathbf{y}; \quad |\mathbf{x}|^2 = a + |\mathbf{y}|^2, \quad 2\mathbf{x} \cdot \mathbf{y} = b, \quad |\mathbf{x}|^2 + |\mathbf{y}|^2 = 4 \right\}.$$

For every  $w = a + ib \in D$  define  $\Gamma_w : \partial E_w \rightarrow \partial \mathbb{M}$ ,

$$\begin{aligned} \partial F_w \ni \mathbf{x} + i\mathbf{y} \mapsto \begin{cases} \mathbf{u} = c_1(w)\mathbf{x}, \\ \mathbf{v} = c_3(w)(\mathbf{y} + c_2(w)\mathbf{x}), \end{cases} & (5.19) \\ |\mathbf{u}| = 1, \quad |\mathbf{v}| \leq 1, \end{aligned}$$

where

$$\begin{aligned} c_1(w) &= \left( \frac{2}{4+a} \right)^{1/2}, \quad c_2(w) = -\frac{b}{4+a}, \\ c_3(w) &= \left( \frac{8+2a}{16-a^2-b^2} \right)^{1/2}. \end{aligned} \quad (5.20)$$

Observe that  $\Gamma_1$  coincides with the identification  $(\Phi)$  between  $F$  and  $\mathbb{M}$ . The family  $(\Gamma_w)_{|w|<\rho}$  defines a trivialization  $\Gamma : \partial E \rightarrow \partial \mathbb{M} \times D$ ,  $\mathbf{z} \mapsto (\Gamma_{f(\mathbf{z})}(\mathbf{z}), f(\mathbf{z}))$ . We set

$$E_{|w|=1} := f^{-1}(\{|w|=1\}) \cap \bar{B} = E|_{\{|w|=1\}}.$$

The manifold  $E_{|w|=1}$  is a smooth compact manifold with boundary

$$\partial E_{|w|=1} = f^{-1}(\{|w|=1\}) \cap \partial \bar{B}.$$

The boundary  $\partial E_{|w|=1}$  fibers over  $\{|w|=1\}$  and is the restriction to the unit circle  $\{|w|=1\}$  of the trivial fibration  $\partial E \rightarrow D$ . The above trivialization  $\Gamma$  of  $\partial E \rightarrow D$  induces a trivialization of  $\partial E_{|w|=1} \rightarrow \{|w|=1\}$ .

Fix a vector field  $V$  on  $E_{|w|=1}$  such that

$$f_*(V) = 2\pi\partial_\theta \quad \text{and} \quad \Gamma_*(V|_{\partial E_{|w|=1}}) = 2\pi\partial_\theta \quad \text{on} \quad \partial \mathbb{M} \times \{|w|=1\}.$$

Denote by  $\mu_t$  the time  $t$ -map of the flow determined by  $V$ . Observe that  $\mu_t$  defines a diffeomorphism

$$\mu_t : F \rightarrow F_{e^{2\pi it}}$$

compatible with the chosen trivialization  $\Gamma_w$  of  $\partial E$ . More precisely, this means that the diagram below is commutative:

$$\begin{array}{ccc} \partial F & \xrightarrow{\Gamma_1(=\Phi)} & \partial\mathbb{M} \\ \mu_t \downarrow & & \downarrow \mathbf{1}_{\partial\mathbb{M}} \\ \partial F_{e^{2\pi it}} & \xrightarrow{\Gamma_{e^{2\pi it}}} & \partial\mathbb{M} \end{array}$$

Consider also the flow  $\Omega_t$  on  $E_{|w|=1}$  given by

$$\Omega_t(\mathbf{z}) = \exp(\pi it)\mathbf{z} = (\cos(\pi t)\mathbf{x} - \sin(\pi t)\mathbf{y}) + i(\sin(\pi t)\mathbf{x} + \cos(\pi t)\mathbf{y}). \quad (5.21)$$

This flow is periodic, and since  $f(\Omega_t\mathbf{z}) = e^{2\pi it}f(\mathbf{z})$ , it satisfies

$$\Omega_t(F) = F_{e^{2\pi it}}.$$

However,  $\Omega_t$  is *not compatible* with the chosen trivialization of  $\partial E$ , because  $\Omega_1|_{\partial F_1}$  is the antipodal map  $\mathbf{z} \mapsto -\mathbf{z}$ .

We pick two geometric representatives  $T_{\pm} \subset F$  of  $\nabla$ . More precisely, we define  $T_+$  so that  $\mathbb{T}_+ = \Phi(T_+) \subset \mathbb{M}$  is the fiber of  $\mathbb{M} \rightarrow \mathbb{S}$  over the north pole  $P_+ \in \mathbb{S}$ . As we have seen in the previous section,  $\mathbb{T}_+$  is oriented by

$$dv_2 \wedge \cdots \wedge dv_n \longleftrightarrow dy_2 \wedge \cdots \wedge dy_n.$$

Define  $\mathbb{T}_- \subset \mathbb{M}$  as the fiber of  $\mathbb{M} \rightarrow \mathbb{S}$  over the south pole  $P_- \in \mathbb{S}$  and set  $T_- = \Phi^{-1}(\mathbb{T}_-)$ .

The orientation of  $\mathbb{S}$  at  $P_-$  is determined by the outer-normal-first convention, and we deduce that it is given by  $-du_2 \wedge \cdots \wedge du_n$ . We deduce that  $\mathbb{T}_-$  is oriented by  $-dv_2 \wedge \cdots \wedge dv_n$ . Inside  $F$  the chain  $T_-$  is described by

$$\mathbf{x} = (1 + |\mathbf{y}|^2/\alpha^2)^{1/2}\mathbf{u}_- \iff x_1 < 0, \quad x_2 = \cdots = x_n = 0,$$

and it is oriented by  $-dy_2 \wedge \cdots \wedge dy_n$ .

Note that  $\Omega_1 = -1$ , so that taking into account the orientations, we have

$$\Omega_1(T_+) = (-1)^n T_- = (-1)^n \nabla. \quad (5.22)$$

For any smooth oriented submanifolds  $A, B$  of  $\mathbb{M}$  with disjoint boundaries  $\partial A \cap \partial B = \emptyset$ , of complementary dimensions, and intersecting transversally, we denote by  $A \circ B$  their intersection number computed using the *bundle orientation* on  $F$ . Set

$$m := m_1(\mathbf{or}_{bundle}) = \nabla \circ \mathbf{var}(\nabla).$$

**Step 1.**

$$m = (-1)^n \Omega_1(T_+) \circ \mu_1(T_+).$$

Note that

$$m = \nabla \circ (\mu_1(T_+) - T_+) = T_- \circ (\mu_1(T_+) - T_+).$$

Observe that the manifolds  $T_+$  and  $T_-$  in  $F$  are disjoint so that

$$m = T_- \circ \mu_1(T_+) \stackrel{(5.22)}{=} (-1)^n \Omega_1(T_+) \circ \mu_1(T_+).$$

**Step 2.**

$$\Omega_1(T_+) \circ \mu_1(T_+) = \Omega_t(T_+) \circ \mu_t(T_+), \quad \forall t \in (0, 1].$$

To see this, observe that the manifolds  $\Omega_t(T_+)$  and  $\mu_t(T_+)$  have disjoint boundaries if  $0 < t \leq 1$ . Indeed, the compatibility of  $\mu_t$  with the boundary trivialization  $\Gamma$  implies

$$\Gamma_{e^{2\pi it}} \mu_t(\partial T_+) = \Gamma_{e^{2\pi it}} \mu_t \Phi^{-1}(\partial \mathbb{T}_+) = \partial \mathbb{T}_+ = \{(\mathbf{u}_+, \mathbf{v}) \in \mathbb{M}; \mathbf{v} = 1\}.$$

On the other hand,

$$\begin{aligned} \Gamma_{e^{2\pi it}} \Omega_t(\partial T_+) &= \Gamma_{e^{2\pi it}} \Omega_t \Phi^{-1}(\partial \mathbb{T}_+) \\ &= \Gamma_{e^{2\pi it}} \Omega_t \left( \sqrt{\frac{1+\alpha^2}{\alpha^2}} \cdot \mathbf{u}_+, \alpha^{-1} \mathbf{v} \right) \quad (\alpha^2 = 2/3), \end{aligned}$$

and from the explicit descriptions (5.19) for  $\Gamma_{e^{2\pi it}}$  and (5.21) for  $\Omega_t$  we deduce

$$\emptyset = \Gamma_{e^{2\pi it}} \Omega_t(\partial T_+) \cap \partial \mathbb{T}_+ = \Gamma_{e^{2\pi it}} \Omega_t(\partial T_+) \cap \Gamma_{e^{2\pi it}} \mu_t(\partial T_+).$$

Hence the deformations

$$\Omega_1(T_+) \rightarrow \Omega_{1-s(1-t)}(T_+), \quad \mu_1(T_+) \rightarrow \mu_{1-s(1-t)}(T_+)$$

do not change the intersection numbers.

**Step 3.**

$$\Omega_t(T_+) \circ \mu_t(T_+) = 1 \quad \text{if } t > 0 \text{ is sufficiently small.}$$

Set

$$A_t := \Omega_t(T_+), \quad B_t = \mu_t(T_+).$$

For  $0 < \varepsilon \ll 1$  denote by  $C_\varepsilon$  the arc  $C_\varepsilon = \{\exp(2\pi it); 0 \leq t \leq \varepsilon\}$ . Extend the trivialization  $\Gamma : \partial E|_{C_\varepsilon} \rightarrow \partial \mathbb{M} \times C_\varepsilon$  to a trivialization

$$\tilde{\Gamma} : E|_{C_\varepsilon} \rightarrow \mathbb{M} \times C_\varepsilon$$

such that  $\tilde{\Gamma}|_F = \Phi$ .

For  $t \in [0, \varepsilon]$  we can view  $\Omega_t$  and  $\mu_t$  as diffeomorphisms  $\omega_t, h_t : \mathbb{M} \rightarrow \mathbb{M}$  such that the diagrams below are commutative:

$$\begin{array}{ccc} F & \xrightarrow{\tilde{\Gamma}_1} & \mathbb{M} \\ \Omega_t \downarrow & & \downarrow \omega_t \\ F_{w(t)} & \xrightarrow{\tilde{\Gamma}_{w(t)}} & \mathbb{M} \end{array} \quad \begin{array}{ccc} F & \xrightarrow{\tilde{\Gamma}_1} & \mathbb{M} \\ \mu_t \downarrow & & \downarrow h_t \\ F_{e^{2\pi it}} & \xrightarrow{\tilde{\Gamma}_{e^{2\pi it}}} & \mathbb{M} \end{array}$$



Set  $\mathbb{A}_t = \tilde{\Gamma}_{e^{2\pi it}}(A_t) = \omega_t(\mathbb{T}_+)$  and  $\mathbb{B}_t = \tilde{\Gamma}_{e^{2\pi it}}(B_t) = h_t(\mathbb{T}_+)$ . Clearly

$$A_t \circ B_t = \mathbb{A}_t \circ \mathbb{B}_t.$$

Observe that  $h_t|_{\partial\mathbb{M}} = \mathbb{1}_{\mathbb{M}}$ , so that  $\mathbb{B}_t(\mathbb{T}_+)$  is homotopic to  $\mathbb{T}_+$  via homotopies that are trivial along the boundary. Such homotopies do not alter the intersection number, and we have

$$\mathbb{A}_t \circ \mathbb{B}_t = \mathbb{A}_t \circ \mathbb{T}_+.$$

Along  $\partial\mathbb{M}$  we have

$$\omega_t|_{\partial M} = \Psi_t := \Gamma_{e^{2\pi it}} \circ \Omega_t \circ \Gamma_1^{-1}. \quad (5.23)$$

Choose  $0 < \hbar < \frac{1}{2}$ . For  $t$  sufficiently small the manifold  $\mathbb{A}_t$  lies in the tubular neighborhood

$$U_{\hbar} := \left\{ (\boldsymbol{\xi}, \boldsymbol{\eta}); |\boldsymbol{\xi}| < r, |\boldsymbol{\eta}| \leq 1 \right\}$$

of fiber  $\mathbb{T}_+ \subset \mathbb{M}$ , where as in (5.17) we set  $\boldsymbol{\xi} = (u_2, \dots, u_n)$  and  $\boldsymbol{\eta} = (v_2, \dots, v_n)$ . More precisely, if  $P = (\mathbf{u}, \mathbf{v})$  is a point of  $\mathbb{M}$  near  $P_+$  then its  $(\boldsymbol{\xi}, \boldsymbol{\eta})$ -coordinates are  $\mathbf{pr}(\mathbf{u}, \mathbf{v})$ , where  $\mathbf{pr}$  denotes the orthogonal projection

$$\mathbf{pr} : \mathbb{R}^n \times \mathbb{R}^n \rightarrow \mathbb{R}^{n-1} \times \mathbb{R}^{n-1}, \quad (\mathbf{u}, \mathbf{v}) \mapsto (u_2, \dots, u_n; v_2, \dots, v_n).$$

We can now rewrite (5.23) entirely in terms of the local coordinates  $(\boldsymbol{\xi}, \boldsymbol{\eta})$  as

$$\omega_t(\boldsymbol{\xi}, \boldsymbol{\eta}) = \mathbf{pr} \circ \Psi_t = \mathbf{pr} \circ \Gamma_{w(t)} \circ \Omega_t \circ \Gamma_1^{-1} \left( u(\boldsymbol{\xi}, \boldsymbol{\eta}), \mathbf{v}(\boldsymbol{\xi}, \boldsymbol{\eta}) \right).$$

The coordinates  $(\boldsymbol{\xi}, \boldsymbol{\eta})$  have a very attractive feature. Namely, in these coordinates, along  $\partial\mathbb{M}$ , the diffeomorphism  $\Psi_t$  is the restriction to  $\partial\mathbb{M}$  of a (real) linear operator

$$L_t : \mathbb{R}^{n-1} \times \mathbb{R}^{n-1} \rightarrow \mathbb{R}^{n-1} \times \mathbb{R}^{n-1}.$$

More precisely,

$$L_t \begin{bmatrix} \boldsymbol{\xi} \\ \boldsymbol{\eta} \end{bmatrix} = C(t)R(t)C(0)^{-1} \cdot \begin{bmatrix} \boldsymbol{\xi} \\ \boldsymbol{\eta} \end{bmatrix},$$

where

$$C(t) := \begin{bmatrix} \mathbf{c}_1(t) & 0 \\ \mathbf{c}_2(t)\mathbf{c}_3(t) & \mathbf{c}_3(t) \end{bmatrix}, \quad R(t) := \begin{bmatrix} \cos(\pi t) & -\sin(\pi t) \\ \sin(\pi t) & \cos(\pi t) \end{bmatrix},$$

and  $\mathbf{c}_k(t) := c_k(e^{2\pi it})$ ,  $k = 1, 2, 3$ . The exact description of  $c_k(w)$  is given in (5.20). We can thus replace  $\mathbb{A}_t = \omega_t(\mathbb{T}_+)$  with  $L_t(\mathbb{T}_+)$  for all  $t$  sufficiently small without affecting the intersection number because  $L_t$  is very close to  $\omega_t$  for  $t$  small and  $\partial\mathbb{A}_t = \partial L_t(\mathbb{T}_+)$ .

For  $t$  sufficiently small we have

$$L_t = L_0 + t\dot{L}_0 + O(t^2), \quad L_0 = \mathbb{1}, \quad \dot{L}_0 := \left. \frac{d}{dt} \right|_{t=0} L_t,$$

where

$$\dot{L}_0 = \dot{C}(0)C(0)^{-1} + C(0)JC(0)^{-1}, \quad J = \dot{R}(0) = \pi \begin{bmatrix} 0 & -1 \\ 1 & 0 \end{bmatrix}.$$

Using (5.20) with  $a = \cos(2\pi t)$ ,  $b = \sin(2\pi t)$  we deduce

$$\begin{aligned} \mathbf{c}_1(0) &= \sqrt{\frac{2}{5}} > 0, \quad \mathbf{c}_2(0) = 0, \quad \mathbf{c}_3(0) = \sqrt{\frac{2}{3}} > 0, \\ \dot{\mathbf{c}}_1(0) &= \dot{\mathbf{c}}_3(0) = 0, \quad \dot{\mathbf{c}}_2(0) = -\frac{2\pi}{25}. \end{aligned}$$

Thus

$$\begin{aligned} \dot{C}(0) &= -\frac{2\pi}{25} \begin{bmatrix} 0 & 0 \\ \mathbf{c}_3(0) & 0 \end{bmatrix}, \quad C(0)^{-1} = \begin{bmatrix} \frac{1}{\mathbf{c}_1(0)} & 0 \\ 0 & \frac{1}{\mathbf{c}_3(0)} \end{bmatrix} \\ \dot{C}(0)C(0)^{-1} &= -\frac{2\pi}{25} \begin{bmatrix} 0 & 0 \\ \frac{\mathbf{c}_3(0)}{\mathbf{c}_1(0)} & 0 \end{bmatrix}. \end{aligned}$$

Next

$$\begin{aligned} C(0)JC(0)^{-1} &= \pi \begin{bmatrix} \mathbf{c}_1(0) & 0 \\ 0 & \mathbf{c}_3(0) \end{bmatrix} \begin{bmatrix} 0 & -1 \\ 1 & 0 \end{bmatrix} \begin{bmatrix} \frac{1}{\mathbf{c}_1(0)} & 0 \\ 0 & \frac{1}{\mathbf{c}_3(0)} \end{bmatrix} \\ &= \pi \begin{bmatrix} \mathbf{c}_1(0) & 0 \\ 0 & \mathbf{c}_3(0) \end{bmatrix} \begin{bmatrix} 0 & -\frac{1}{\mathbf{c}_3(0)} \\ \frac{1}{\mathbf{c}_1(0)} & 0 \end{bmatrix} = \pi \begin{bmatrix} 0 & -\frac{\mathbf{c}_1(0)}{\mathbf{c}_3(0)} \\ \frac{\mathbf{c}_3(0)}{\mathbf{c}_1(0)} & 0 \end{bmatrix}. \end{aligned}$$

The upshot is that the matrix  $\dot{L}_0$  has the form

$$\dot{L}_0 = \begin{bmatrix} 0 & -a \\ b & 0 \end{bmatrix}, \quad a, b > 0.$$

For  $t$  sufficiently small we can now deform  $L_t(\mathbb{T}_+)$  to  $(L_0 + t\dot{L}_0)(\mathbb{T}_+)$  such that during the deformation the boundary of the deforming relative cycle does not intersect the boundary of  $\mathbb{T}_+$ . Such deformation again does not alter the intersection number. Now observe that  $\Sigma_t := (L_0 + t\dot{L}_0)(\mathbb{T}_+)$  is the portion inside  $U_{\hbar}$  of the  $(n-1)$ -subspace

$$\boldsymbol{\eta} \mapsto (L_0 + t\dot{L}_0) \begin{bmatrix} 0 \\ \boldsymbol{\eta} \end{bmatrix} = \begin{bmatrix} -t\mathbf{a}\boldsymbol{\eta} \\ \boldsymbol{\eta} \end{bmatrix}.$$

It carries the orientation given by

$$(-t\mathbf{a} du_2 + dv_2) \wedge \cdots \wedge (-t\mathbf{a} du_n + dv_n).$$

Observe that  $\Sigma_t$  intersects the  $(n-1)$ -subspace  $\mathbb{T}_+$  given by  $\boldsymbol{\xi} = 0$  transversely at the origin, so that

$$\Sigma_t \circ \mathbb{T}_+ = \pm 1.$$

The sign coincides with the sign of the real number  $\nu$  defined by

$$\begin{aligned} \nu & dv_2 \wedge \cdots \wedge dv_n \wedge du_2 \wedge \cdots \wedge du_n \\ &= (-ta \, du_2 + dv_2) \wedge \cdots \wedge (-ta \, du_n + dv_n) \wedge dv_2 \wedge \cdots \wedge dv_n \\ &= (-ta)^{n-1} \, du_2 \wedge \cdots \wedge du_n \wedge dv_2 \wedge \cdots \wedge dv_n \\ &= (-1)^{(n-1)+(n-1)^2} \, dv_2 \wedge \cdots \wedge dv_n \wedge du_2 \wedge \cdots \wedge du_n \end{aligned}$$

Since  $(n - 1) + (n - 1)^2$  is even, we deduce that  $\nu$  is positive so that

$$1 = \Sigma_t \circ \mathbb{T}_t = \Omega_t(T_+) \circ \mu_t(T_+), \quad \forall 0 < t \ll 1.$$

This completes the proof of the local Picard–Lefschetz formula. □

*Remark 5.30.* For a slightly different proof we refer to [Lo]. For a more conceptual proof of the Picard–Lefschetz formula in the case that  $n = \dim_{\mathbb{C}} S$  is odd, we refer to [AGV2, Section 2.4]. □

### 5.6 Global Picard–Lefschetz Formulæ

Consider a Lefschetz pencil  $(X_s)$  on  $X \hookrightarrow \mathbb{P}^N$  with associated Lefschetz fibration  $\hat{f} : \hat{X} \rightarrow S \cong \mathbb{P}^1$  such that all its critical values  $t_1, \dots, t_r$  are situated in the upper hemisphere in  $D_+ \subset S$ . We denote its critical points by  $p_1, \dots, p_r$ , so that

$$\hat{f}(p_j) = t_j, \quad \forall j.$$

We will identify  $D_+$  with the closed unit disk centered at  $0 \in \mathbb{C}$ . We assume  $|t_j| < 1$  for  $j = 1, \dots, r$ . Fix a point  $* \in \partial D_+$ . For  $j = 1, \dots, r$  we make the following definitions:

- $D_j$  is a closed disk of very small radius  $\rho$  centered at  $t_j \in D_+$ . If  $\rho \ll 1$  these disks are pairwise disjoint.
- $\ell_j : [0, 1] \rightarrow D_+$  is a smooth *embedding* connecting  $* \in \partial D_+$  to  $t_j + \rho \in \partial D_j$  such that the resulting paths  $\ell_1, \dots, \ell_r$  are disjoint (see Figure 5.2). Set  $k_j := \ell_j \cup D_j$ ,  $\ell = \bigcup \ell_j$  and  $k = \bigcup k_j$ .
- $B_j$  is a small ball in  $\hat{X}$  centered at  $p_j$ .

Denote by  $\gamma_j$  the loop in  $D_+ \setminus \{t_1, \dots, t_r\}$  based at  $*$  obtained by traveling along  $\ell_j$  from  $*$  to  $t_j + \rho$  and then once counterclockwise around  $\partial D_j$  and then back to  $*$  along  $\ell_j$ . The loops  $\gamma_j$  generate the fundamental group

$$\pi_1(S^*, *), \quad S^* := S \setminus \{t_1, \dots, t_r\}.$$

Set

$$\hat{X}_{S^*} := \hat{f}^{-1}(S^*).$$

We have a fibration

$$\hat{f} : \hat{X}_{S^*} \rightarrow S^*,$$

and as in the previous section, we have an action

$$\mu : \pi_1(S^*, *) \rightarrow \text{Aut}(H_\bullet(\hat{X}_*, \mathbb{Z}))$$

called *the monodromy of the Lefschetz fibration*. Since  $X_*$  is canonically diffeomorphic to  $\hat{X}_*$ , we will write  $X_*$  instead of  $\hat{X}_*$ .

From the proof of the local Picard–Lefschetz formula we deduce that for each critical point  $p_j$  of  $\hat{f}$  there exists an *oriented*  $(n-1)$ -sphere  $\Sigma_j$  embedded in the fiber  $X_{t_j+\rho}$  which bounds a *thimble*, i.e., an oriented embedded  $n$ -disk  $Z_j \subset \hat{X}_+$ . This disk is spanned by the family of vanishing spheres in the fibers over the radial path from  $t_j + \rho$  to  $t_j$ .

We denote by  $\Delta_j \in H_{n-1}(X_{t_j+\rho}, \mathbb{Z})$  the homology class determined by the vanishing sphere  $\Sigma_j$  in the fiber over  $t_j + \rho$ . In fact, using (5.18) we deduce

$$\Delta_j * \Delta_j = (-1)^{n(n-1)/2} \left( 1 + (-1)^{n-1} \right) = \begin{cases} 0 & \text{if } n \text{ is even,} \\ -2 & \text{if } n \equiv -1 \pmod{4}, \\ 2 & \text{if } n \equiv 1 \pmod{4}. \end{cases}$$

The above intersection pairing is the one determined by the *complex orientation* of  $X_{t_j+\rho}$ .

Note that for each  $j$  we have a canonical isomorphism

$$H_\bullet(X_j, \mathbb{Z}) \rightarrow H_\bullet(X_*, \mathbb{Z})$$

induced by a trivialization of  $\hat{f} : \hat{X}_{S^*} \rightarrow S^*$  over the path  $\ell_j$  connecting  $*$  to  $t_j + \rho$ . This isomorphism is independent of the choice of trivialization since any two trivializations are homotopic. For this reason we will freely identify  $H_\bullet(X_*, \mathbb{Z})$  with any  $H_\bullet(X_j, \mathbb{Z})$ .

Using the local Picard–Lefschetz formula we obtain the following important result.

**Theorem 5.31 (Global Picard–Lefschetz formula).** *If  $z \in H_{n-1}(X_*, \mathbb{Z})$ , then*

$$\mathbf{var}_{\gamma_j}(z) := \mu_{\gamma_j}(z) - z = -(-1)^{n(n-1)/2} (z * \Delta_j) \Delta_j.$$

*Proof.* We prove the result only for the homology with real coefficients, since it contains all the main ideas and none of the technical drag. For simplicity, we set  $X_j := X_{t_j+\rho}$ . We think of the cohomology  $H^\bullet(X_j)$  as the De Rham cohomology of  $X_j$ .

Represent the Poincaré dual of  $z$  by a closed  $(n-1)$ -form  $\zeta$  on  $X_j$  and the Poincaré dual of  $\Delta_j$  by an  $(n-1)$ -form  $\delta_j$  on  $X_j$ . We use the sign conventions<sup>8</sup>

<sup>8</sup> Given an oriented submanifold  $S \subset X_*$  its Poincaré dual should satisfy either  $\int_S \omega = \int_{X_*} \omega \wedge \delta_S$  or  $\int_S \omega = \int_{X_*} \delta_S \wedge \omega$ ,  $\forall \omega \in \Omega^{\dim S}(X_*)$ ,  $d\omega = 0$ . Our sign convention corresponds to first choice. As explained in [Ni1, Prop. 7.3.9] this guarantees that for any two oriented submanifolds  $S_1, S_2$  intersecting transversally we have  $S_1 * S_2 = \int_{X_*} \delta_{S_1} \wedge \delta_{S_2}$ .

of [Nil, Section 7.3], which means that for every closed form  $\omega \in \Omega^{n-1}(X_*)$  we have

$$\begin{aligned} \int_{\Sigma_j} \omega &= \int_{X_j} \omega \wedge \delta_j, \\ \Delta_j * z &= \int_{X_j} \delta_j \wedge \zeta = (-1)^{n-1} \int_{X_j} \zeta \wedge \delta_j = (-1)^{n-1} \int_{\Sigma_j} \zeta. \end{aligned}$$

We can assume that  $\delta_j$  is supported in a small tubular neighborhood  $U_j$  of  $\Sigma_j$  in  $X_{t_j+\rho}$  diffeomorphic to the unit disk bundle of  $T\Sigma_j$ .

The monodromy  $\mu_{\gamma_j}$  can be represented by a diffeomorphism  $h_j$  of  $X_j$  that acts trivially outside a compact subset of  $U_j$ . In particular,  $h_j$  is orientation preserving. We claim that the Poincaré dual of  $\mu_{\gamma_j}(z)$  can be represented by the closed form  $(h_j^{-1})^*(\zeta)$ .

The easiest way to see this is in the special case in which  $z$  is represented by an oriented submanifold  $Z$ . The cycle  $\mu_{\gamma_j}(z)$  is represented by the submanifold  $h_j(Z)$  and for every  $\omega \in \Omega^{n-1}(X_j)$  we have

$$\begin{aligned} \int_{h_j(Z)} \omega &= \int_Z h_j^* \omega = \int_{X_j} h_j^* \omega \wedge \zeta = \int_{X_j} h_j^* \omega \wedge h_j^* ((h_j^{-1})^* \zeta) \\ &= \int_{X_j} h_j^* (\omega \wedge (h_j^{-1})^* \zeta) = \int_{X_j} \omega \wedge (h_j^{-1})^* \zeta. \end{aligned}$$

At the last step we used the fact that  $h_j$  is orientation preserving. As explained in the footnote, the equality

$$\int_{h_j(Z)} \omega = \int_{X_j} \omega \wedge (h_j^{-1})^* \zeta, \quad \forall \omega$$

implies that  $(h_j^{-1})^* \zeta$  represents the Poincaré dual of  $\mu_{\gamma_j}(z)$ .

This is not quite a complete proof of the claim, since there could exist cycles that cannot be represented by embedded, oriented smooth submanifolds. However, the above reasoning can be made into a complete proof if we define carefully the various operations it relies on. We leave the details to the reader (see Exercise 6.52).

Observe that  $(h_j^{-1})^* \zeta = \zeta$  outside  $U_j$ , so that the difference  $(h_j^{-1})^* \zeta - \zeta$  is a closed  $(n-1)$ -form with compact support in  $U_j$ . It determines an element in  $H_{cpt}^{n-1}(U_j)$ .

On the other hand,  $H_{cpt}^{n-1}(U_j)$  is a one dimensional vector space spanned by the cohomology class carried by  $\delta_j$ . Hence there exist a real constant  $c$  and a form  $\eta \in \Omega^{n-2}(U_j)$  with compact support such that

$$(h_j^{-1})^* \zeta - \zeta = c\delta_j + d\eta. \quad (5.24)$$

We have (see [Nil, Lemma 7.3.12])

$$\int_{\nabla_j} \delta_j = \Delta_j * \nabla_j = (-1)^{n-1} \nabla_j * \Delta_j,$$

so that

$$\begin{aligned} (-1)^{n-1} c(\nabla_j * \Delta_j) &= \int_{\nabla_j} c \delta_j = \int_{\nabla_j} ((h_j^{-1})^* \zeta - \zeta) - \int_{\nabla_j} d\eta \\ &= \int_{h_j(\nabla_j) - \nabla_j} \zeta, \end{aligned}$$

where

$$\int_{\nabla_j} d\eta \stackrel{\text{Stokes}}{=} \int_{\partial \nabla_j} \eta = 0,$$

since  $\eta$  has compact support in  $U_j$ .

Invoking (5.18) we deduce

$$(\nabla_j * \Delta_j) = (-1)^{n(n-1)/2}.$$

The (piecewise smooth) singular chain  $h(\nabla_j) - \nabla_j$  is a *cycle* in  $U_j$  representing  $\mathbf{var}_{\gamma_j}(\nabla_j) \in H_{n-1}(U_j)$ . The local Poincaré–Lefschetz formula shows that this cycle is homologous in  $U_j$  (and thus in  $X_{t_j+\rho}$  as well) to  $(-1)^n \Sigma_j$ :

$$\begin{aligned} (-1)^{n+1} c &= (-1)^{n-1} c = (-1)^{n(n-1)/2} \int_{\mathbf{var}_{\gamma_j}(\nabla_j)} \zeta \\ &= (-1)^{n(n-1)/2} \cdot (-1)^n \int_{\Sigma_j} \zeta = (-1)^{n+n(n-1)/2} \Delta_j * z. \end{aligned}$$

Thus

$$c = -(-1)^{n(n-1)/2} (z * \Delta_j).$$

Substituting this value of  $c$  in (5.24) and then applying the Poincaré duality, we obtain

$$\mu_j(z) - z = -(-1)^{n(n-1)/2} (z * \Delta_j) \Delta_j. \quad \square$$

**Definition 5.32.** *The monodromy group of the Lefschetz pencil  $(X_s)_{s \in S}$  of  $X$  is the subgroup of  $\mathfrak{G} \subset \text{Aut}(H_{n-1}(X_*, \mathbb{Z}))$  generated by the monodromies  $\mu_{\gamma_j}$ .*  $\square$

*Remark 5.33.* (a) When  $n = 2$ , so that the divisors  $X_s$  are complex curves (Riemann surfaces), then the monodromy  $\mu_j$  along an elementary loop  $\ell_j$  is known as a *Dehn twist* associated with the corresponding vanishing sphere. The action of such a Dehn twist on a cycle intersecting the vanishing sphere is depicted in Figure 5.5. The Picard–Lefschetz formula in this case states that the monodromy is a (right-handed) Dehn twist.

(b) Suppose  $n$  is odd, so that

$$\Delta_j * \Delta_j = 2(-1)^{(n-1)/2}.$$

Denote by  $q$  the intersection form on  $L := H_{n-1}(X_*, \mathbb{Z})/\text{Tors}$ . It is a *symmetric* bilinear form because  $n - 1$  is even. An element  $u \in L$  defines the orthogonal reflection  $R_u : L \otimes \mathbb{R} \rightarrow L \otimes \mathbb{R}$  uniquely determined by the requirements

$$R_u(x) = x + t(x)u, \quad q(u, x + \frac{t(x)}{2}u) = 0, \quad \forall x \in L \otimes \mathbb{R}$$

$$\iff R_u(x) = x - \frac{2q(x, u)}{q(u, u)}u.$$

We see that the reflection defined by  $\Delta_j$  is

$$R_j(x) = x + (-1)^{(n+1)/2}q(x, \Delta_j)\Delta_j = x - (-1)^{n(n-1)/2}q(x, \Delta_j)\Delta_j.$$

This reflection preserves the lattice  $L$ , and it is precisely the monodromy along  $\gamma_j$ . This shows that the monodromy group  $\mathfrak{G}$  is a group generated by reflections preserving the intersection lattice  $H_{n-1}(X_*, \mathbb{Z})/\text{Tors}$ .  $\square$

The vanishing submodule

$$\mathbb{V}(X_*) : \text{Image} \left( \partial : H_n(\hat{X}_+, \hat{X}_*; \mathbb{Z}) \rightarrow H_{n-1}(\hat{X}_*, \mathbb{Z}) \right) \subset H_{n-1}(\hat{X}_*, \mathbb{Z})$$

is spanned by the vanishing cycles  $\Delta_j$ . We can now explain why the invariant cycles are called invariant.

Since  $\mathbb{V}(X_*)$  is spanned by the vanishing spheres, we deduce from (5.11) that

$$\mathbb{I}(X_*) := \{ y \in H_{n-1}(X_*, \mathbb{Z}); \quad y * \Delta_j = 0, \quad \forall j \}$$

(use the global Picard–Lefschetz formula)

$$= \{ y \in H_{n-1}(X_*, \mathbb{Z}); \quad \mu_{\gamma_j}y = y, \quad \forall j \}.$$

We have thus proved the following result.

**Proposition 5.34.** *The module  $\mathbb{I}(X_*)$  consists of the cycles invariant under the action of the monodromy group  $\mathfrak{G}$ .*  $\square$





---

## Exercises and Solutions

### 6.1 Exercises

**Exercise 6.1.** Consider the set

$$\mathcal{Z} = \{ (x, a, b, c) \in \mathbb{R}^4; a \neq 0, ax^2 + bx + c = 0 \}.$$

- (a) Show that  $\mathcal{Z}$  is a smooth submanifold of  $\mathbb{R}^4$ .  
 (b) Find the discriminant set of the projection

$$\pi : \mathcal{Z} \rightarrow \mathbb{R}^3, \pi(x, a, b, c) = (a, b, c). \quad \square$$

**Exercise 6.2.** (a) Fix positive real numbers  $r_1, \dots, r_n$ ,  $n \geq 2$ , and consider the map

$$\beta : (S^1)^n \rightarrow \mathbb{C}$$

given by

$$(S^1)^n \ni (z_1, \dots, z_n) \mapsto \sum_{i=1}^n r_i z_i \in \mathbb{C}.$$

Show that  $x = x + iy$  is a critical value of  $\beta$  if and only if  $x^2 = y^2$ .

- (b) Consider the open subset  $M$  of  $(S^1)^n$  described by  $\mathbf{Re} \beta > 0$ . Show that 0 is a regular value of the function

$$M \ni \mathbf{z} \mapsto \mathbf{Im} \beta(\mathbf{z}) \in \mathbb{R}. \quad \square$$

**Exercise 6.3.** Suppose  $g = g(t_1, \dots, t_n) : \mathbb{R}^n \rightarrow \mathbb{R}$  is a smooth function such that  $g(0) = 0$  and

$$dg(0) = c_1 dt_1 + \dots + c_n dt_n, \quad c_n \neq 0.$$

The implicit function theorem implies that near 0 the hypersurface  $X = \{g = 0\}$  is described as the graph of a smooth function

$$t_n = t_n(t_1, \dots, t_{n-1}) : \mathbb{R}^{n-1} \rightarrow \mathbb{R}.$$

In other words, we can solve for  $t_n$  in the equation  $g(t_1, \dots, t_n) = 0$  if  $\sum_k |t_k|$  is sufficiently small. Show that there exists a neighborhood  $V$  of  $0 \in \mathbb{R}^n$  and  $C > 0$  such that for every  $(t_1, \dots, t_{n-1}, t_n) \in V \cap X$  we have

$$\left| t_n + \frac{c_1 t_1 + \dots + c_{n-1} t_{n-1}}{c_n} \right| \leq C(t_1^2 + \dots + t_{n-1}^2). \quad \square$$

**Exercise 6.4.** (a) Suppose  $f : \mathbb{R} \rightarrow \mathbb{R}$  is a *proper* Morse function, i.e.,  $f^{-1}(\text{compact}) = \text{compact}$ . Prove that the number of critical points of  $f$  is even if  $\lim_{x \rightarrow \infty} f(x)f(-x) = -\infty$ , and it is odd if  $\lim_{x \rightarrow \infty} f(x)f(-x) = \infty$ .

(b) Suppose  $f : S^1 \rightarrow \mathbb{R}$  is a Morse function on  $\mathbb{R}$ . Show that it has an *even* number of critical points, half of which are local minima.  $\square$

**Exercise 6.5.** Prove Lemma 1.32.  $\square$

**Exercise 6.6.** In this exercise we outline a proof of Fenchel's theorem, Remark 1.36. We will use the notations introduced in Section 1.3. Suppose  $K$  is a knot in  $\mathbb{R}^3$  with total curvature  $T_K = 2\pi$ .

(a) Show that for *any*  $\mathbf{v} \in \mathbb{R}^3$  and any  $c \in \mathbb{R}$ , the sublevel set  $\{h_{\mathbf{v}} \leq c\} \subset K$  is connected.

(b) Prove that  $K$  is a planar convex curve.  $\square$

**Exercise 6.7.** Suppose that  $\mathbf{E}$  is an Euclidean space of dimension  $N$  and  $\varphi : S^2 \rightarrow \mathbf{E}$  is a knot. We denote by  $(-, -)$  the inner product on  $\mathbf{E}$  and by  $K$  the image of  $\varphi$ . We fix a *Gaussian* probability measure on  $\mathbf{E}$ ,

$$d\gamma(\mathbf{x}) := (2\pi)^{-\frac{N}{2}} e^{-\frac{|\mathbf{x}|^2}{2}} d\mathbf{x}.$$

For every point  $\mathbf{p} \in K$  we have a random variable

$$\xi_{\mathbf{p}} : \mathbf{E} \rightarrow \mathbb{R}, \quad \xi_{\mathbf{p}}(\mathbf{x}) := (\mathbf{x}, \mathbf{p}).$$

(a) Find the expectation this random variable, i.e., the quantity

$$E(\xi_{\mathbf{p}}) := \int_{\mathbf{E}} \xi_{\mathbf{p}}(\mathbf{x}) d\gamma(\mathbf{x}).$$

(b) Let  $\mathbf{p}_1, \mathbf{p}_2 \in K$ . Find the expectation of the random variable  $\xi_{\mathbf{p}_1} \cdot \xi_{\mathbf{p}_2}$ , i.e., the quantity

$$E(\xi_{\mathbf{p}_1} \xi_{\mathbf{p}_2}) := \int_{\mathbf{E}} \xi_{\mathbf{p}_1}(\mathbf{x}) \xi_{\mathbf{p}_2}(\mathbf{x}) d\gamma(\mathbf{x}).$$

(c) Conclude that for any  $\mathbf{p} \in K$  the random variable  $\xi_{\mathbf{p}}$  is normally distributed.

(d) Prove the equality (1.16).  $\square$

**Exercise 6.8.** Suppose  $K \subset \mathbb{R}^2$  is smooth curve in the plane without self-intersections. Assume that  $0 \notin K$ . Let  $\mathcal{S}$  be the vector space of symmetric  $2 \times 2$  matrices equipped with the inner product

$$(A, B) := \text{tr}(A \cdot B).$$

Denote by  $\mathcal{S}_1$  the unit sphere in  $\mathcal{S}$ ,

$$\mathcal{S}_1 := \{A \in \mathcal{S}; \text{tr } A^2 = 1\},$$

and by  $dS$  the induced volume form on  $\mathcal{S}_1$ . For any  $A \in \mathcal{S}_1$  we obtain a function

$$q_A : K \rightarrow \mathbb{R}, \quad \mathbf{x} \mapsto (A\mathbf{x}, \mathbf{x}).$$

Corollary 1.25 shows that  $q_A$  is a Morse function for almost all  $A \in \mathcal{S}_1$ . Denote by  $N_K(A)$  the number of critical points of  $q_A$ . Express

$$\int_{\mathcal{S}_1} N_K(A) dS(A)$$

in terms of differential geometric invariants of  $K$ .  $\square$

**Exercise 6.9.** For every  $(\mathbf{x}, \mathbf{y}) \in \mathbb{R}^n \times \mathbb{R}^n$  we denote by  $T_{\mathbf{x}, \mathbf{y}}$  the trigonometric polynomial

$$T_{\mathbf{x}, \mathbf{y}}(\theta) = \sum_{k=1}^n (x_k \cos k\theta + y_k \sin \theta),$$

and by  $N(\mathbf{x}, \mathbf{y})$  the number of critical points of  $T_{\mathbf{x}, \mathbf{y}}$  viewed as a smooth map  $S^1 \times \mathbb{R}$ . We set

$$\mu_n := \frac{1}{\text{area}(S^{2n-1})} \int_{S^{2n-1}} N(\mathbf{x}, \mathbf{y}) dA(\mathbf{x}, \mathbf{y}),$$

where  $dA$  denotes the area element on the unit sphere  $S^{2n-1} \subset \mathbb{R}^n \times \mathbb{R}^n$ . Note that  $\mu_n$  can be interpreted as the average number of critical points of a random trigonometric polynomial of degree  $\leq n$ . Show that

$$\lim_{n \rightarrow \infty} \frac{\mu_n}{2n} = \sqrt{\frac{3}{5}}.$$

$\square$

**Exercise 6.10 (Raleigh-Ritz).** Denote by  $S^n$  the unit sphere in  $\mathbb{R}^{n+1}$  equipped with the standard Euclidean metric  $(\bullet, \bullet)$ . Fix a nonzero symmetric  $(n+1) \times (n+1)$  matrix with real entries and define

$$f_A : \mathbb{R}^{n+1} \rightarrow \mathbb{R}, \quad f(\mathbf{x}) = \frac{1}{2}(Ax, x).$$

Describe the matrices  $A$  such that the restriction of  $f_A$  to  $S^n$  is a Morse function. For such a choice of  $A$  find the critical values of  $f_A$ , the critical points, and their indices. Compute the Morse polynomial of  $f_A$ .  $\square$

**Exercise 6.11.** For every vector  $\lambda = (\lambda_0, \dots, \lambda_n) \in \mathbb{R}^n \setminus 0$  we denote by  $f_\lambda : \mathbb{C}\mathbb{P}^n \rightarrow \mathbb{R}$  the smooth function

$$f_\lambda([z_0, \dots, z_n]) = \frac{\lambda_0|z_0|^2 + \dots + \lambda_n|z_n|^2}{|z_0|^2 + \dots + |z_n|^2},$$

where  $[z_0, \dots, z_n]$  denotes the homogeneous coordinates of a point in  $\mathbb{C}\mathbb{P}^n$ .

- (a) Find the critical values and the critical points of  $f_\lambda$ .  
 (b) Describe for what values of  $\lambda$  the critical points of  $f_\lambda$  are nondegenerate and then determine their indices.  $\square$

**Exercise 6.12.** Suppose  $X, Y$  are two finite dimensional connected smooth manifolds and  $f : X \rightarrow Y$  is a smooth map. We say that  $f$  is *transversal* to the smooth submanifold  $S$  if for every  $s \in S$ , every  $x \in f^{-1}(s)$ , we have

$$T_s Y = T_s S + \text{Im}(Df : T_x X \rightarrow T_s Y).$$

- (a) Prove that  $f$  is transversal to  $S$  if and only if for every  $s \in S$ , every  $x \in f^{-1}(s)$ , and every smooth function  $u : Y \rightarrow \mathbb{R}$  such that  $u|_S = 0$  and  $du|_s \neq 0$  we have  $f^*(du)|_x \neq 0$ .  
 (b) Prove that if  $f$  is transversal to  $S$ , then  $f^{-1}(S)$  is a smooth submanifold of  $X$  of the same codimension as  $S \hookrightarrow Y$ .  $\square$

**Exercise 6.13.** Let  $X, Y$  be as in the previous exercise. Suppose  $A$  is a smooth, connected manifold. A *smooth family of submanifolds* of  $Y$  parametrized by  $A$  is a submanifold  $\tilde{S} \subset A \times Y$  with the property that the restriction of the natural projection  $\pi : A \times Y \rightarrow A$  to  $\tilde{S}$  is a submersion  $\pi : \tilde{S} \rightarrow A$ . For every  $\lambda \in A$  we set<sup>1</sup>

$$S_\lambda := \{y \in Y; (\lambda, y) \in \tilde{S}\} = \pi^{-1}(\lambda) \cap \tilde{S}.$$

Consider a smooth map

<sup>1</sup> Note that the collection  $(S_\lambda)_{\lambda \in A}$  is indeed a family of smooth submanifolds of  $Y$ .

$$F : A \times X \rightarrow Y, \quad A \times X \ni (\lambda, x) \mapsto f_\lambda(x) \in Y$$

and suppose that the induced map

$$G : A \times X \rightarrow A \times Y, \quad (\lambda, x) \mapsto (\lambda, f_\lambda(x))$$

is transversal to  $\tilde{S}$ .

Prove that there exists a subset  $A_0 \subset A$  of measure zero such that for every  $\lambda \in A \setminus A_0$  the map  $f_\lambda : X \rightarrow Y$  is transversal to  $S_\lambda$ .  $\square$

*Remark 6.14.* If we let  $\tilde{S} = \{y_0\} \times A$  in the above exercise we deduce that for generic  $\lambda$  the point  $y_0$  is a regular value of  $f_\lambda$  provided it is a regular value of  $F$ .  $\square$

**Exercise 6.15.** Denote by  $(\bullet, \bullet)$  the Euclidean metric on  $\mathbb{R}^{n+1}$ . Suppose  $M \subset \mathbb{R}^{n+1}$  is an *oriented* connected smooth submanifold of dimension  $n$ . This implies that we have a smoothly varying unit normal vector field  $\mathcal{N}$  along  $M$ , which we interpret as a smooth map from  $M$  to the *unit sphere*  $S^n \subset \mathbb{R}^{n+1}$ ,

$$\mathcal{N} = \mathcal{N}_M : M \rightarrow S^n.$$

This is known as the *Gauss map* of the embedding  $M \hookrightarrow \mathbb{R}^{n+1}$ .

For every unit vector  $\mathbf{v} \in S^n \subset \mathbb{R}^{n+1}$  we denote by  $\ell_{\mathbf{v}} : \mathbb{R}^{n+1} \rightarrow \mathbb{R}$  the linear function

$$\ell_{\mathbf{v}}(\mathbf{x}) = (\mathbf{v}, \mathbf{x}).$$

Show that the restriction of  $\ell_{\mathbf{v}}$  to  $M$  is a Morse function if and only if the vector  $\mathbf{v} \in S^n$  is a regular value of the Gauss map  $\mathcal{N}$ .  $\square$

**Exercise 6.16.** Suppose  $\Sigma \hookrightarrow \mathbb{R}^3$  is a compact *oriented* surface without boundary and consider the Gauss map

$$\mathcal{N}_\Sigma : \Sigma \rightarrow S^2$$

defined as in the previous exercise. Denote by  $(\bullet, \bullet) : \mathbb{R}^3 \times \mathbb{R}^3 \rightarrow \mathbb{R}$  the canonical inner product. Recall that in Corollary 1.25 we showed that there exists a set  $\Delta \subset S^2$  of measure zero such that for all  $u \in S^2 \setminus \Delta$  the function

$$\ell_u : \Sigma \rightarrow \mathbb{R}, \quad \ell_u(x) = (u, x)$$

is a Morse function. For every  $u \in S^2 \setminus \Delta$  and any open set  $V \subset \Sigma$  we denote by  $\mathbf{Cr}_u(U)$  the set of critical points of  $\ell_u$  situated in  $U$ . Define

$$\chi_u(V) := \sum_{x \in \mathbf{Cr}_u(U)} (-1)^{\lambda(\ell_u, x)}$$

and

$$m(U) := \frac{1}{\text{area } S^2} \int_{S^2 \setminus \Delta} \chi_u(V) d\sigma(u) = \frac{1}{4\pi} \int_{S^2 \setminus \Delta} \chi_u(V) d\sigma(u).$$

Denote by  $s : \Sigma \rightarrow \mathbb{R}$  the scalar curvature of the metric  $g$  on  $\Sigma$  induced by the Euclidean metric on  $\mathbb{R}^3$  and by  $dV_{S^2}$  the volume form on the unit sphere  $S^2$ . Show that

$$m(u) = \frac{1}{4\pi} \int_U \mathbf{N}_\Sigma^* dV_{S^2} = \frac{1}{4\pi} \int_U s(x) dV_g(x).$$

In particular, conclude that

$$\chi(\Sigma) = \frac{1}{4\pi} \int_\Sigma s(x) dV_g(x). \quad \square$$

**Exercise 6.17.** Suppose  $\Sigma \hookrightarrow \mathbb{R}^3$  is a compact *oriented* surface without boundary. The orientation on  $\Sigma$  defines smooth unit normal vector field

$$\mathbf{n} : \Sigma \rightarrow S^2, \quad \mathbf{n}(p) \perp T_p \Sigma, \quad \forall p \in \Sigma.$$

For every  $u \in \mathbb{R}^3$  we denote by  $q_u$  the function

$$q_u : \Sigma \rightarrow \mathbb{R}, \quad q_u(x) = \frac{1}{2} |x - u|^2.$$

We denote by  $\mathcal{S}$  the set  $u \in \mathbb{R}^3$  such that the function  $q_u$  is a Morse function. We know that  $\mathbb{R}^3 \setminus \mathcal{S}$  has zero Lebesgue measure.

(a) Show that  $p \in \Sigma$  is a critical point of  $q_u$  if and only if there exists  $t \in \mathbb{R}$  such that  $u = p + t\mathbf{n}(p)$ .

(b) Let  $u \in \mathbb{R}^3$  and suppose  $p \in \Sigma$  is a critical point of  $q_u$ . Denote by  $g : T_p \Sigma \times T_p \Sigma \rightarrow \mathbb{R}$  the *first fundamental form* of  $\Sigma \hookrightarrow \mathbb{R}^3$  at  $p$ , i.e., the induced inner product on  $T_p \Sigma$ , and by  $a : T_p \Sigma \times T_p \Sigma \rightarrow \mathbb{R}$  the second fundamental form (see [Str, 2.5]) of  $\Sigma \hookrightarrow \mathbb{R}^3$  at  $p$ . These are symmetric bilinear forms. For every  $t \in \mathbb{R}$  we denote by  $\nu_p(t)$  the nullity of the symmetric bilinear form  $g - ta$ . Since  $p$  is a critical point of  $q_u$  there exists  $t_u = t_u(p) \in \mathbb{R}$  such that  $u = p + t_u \mathbf{n}(p)$ . Show that  $p$  is a nondegenerate critical point of  $q_u$  if and only if  $\nu(t_u) \neq 0$ . In this case, the index of  $q_u$  at  $p$  is

$$\lambda(q_u, p) = \sum_{t \in I_u(p)} \nu(t),$$

where  $I_u(p)$  denotes the interval consisting of all real numbers strictly between 0 and  $t_u(p)$ .

(c)\* For every  $u \in \mathcal{S}$  and every  $p \in \Sigma$  we set

$$e(u, p) := \begin{cases} (-1)^{\lambda(u, p)} & p \text{ critical point of } q_u, \\ 0 & p \text{ regular point of } q_u. \end{cases}$$

For  $r > 0$  and  $U \subset \Sigma$  an open subset of  $\Sigma$  we define

$$\mu_r(U) = \int_{\mathbb{R}^3} \left( \sum_{p \in U, |p-u| < r} e(u, p) \right) du.$$

Show that there exist nonzero *universal constants*  $c_1, c_2$  such that

$$\mu_r(U) = c_1 r \left( \int_U dV_g \right) r + c_2 \left( \int_U s_g dV_g \right) r^3$$

for all  $r$  sufficiently small. Above  $dV_g$  denotes the area form on  $\Sigma$  while  $s_g$  denotes the scalar curvature of the induced metric  $g$  on  $\Sigma$ . If  $U = D_\varepsilon(p_0)$  is a geodesic disk of radius  $\varepsilon$  centered at  $p_0 \in \Sigma$ , then

$$\lim_{\varepsilon \searrow 0} \frac{1}{\text{area}_g(D_\varepsilon(p_0))} \mu_r(D_\varepsilon(p_0)) = c_1 r + c_3 r^3 s_g(p_0), \quad \forall 0 < r \ll 1.$$

□

**Exercise 6.18.** Prove the equality (2.1).

**Exercise 6.19.** Consider the group  $G$  described by the presentation

$$G = \langle a, b \mid aba = bab, a^2 b^2 = aba^{-1}ba \rangle.$$

- (a) Show that  $ab^3a^{-1} = b^2$ ,  $b^3 = ba^2b^{-1}$ , and  $a^2 = b^3$ .  
 (b) Show that  $G$  is isomorphic to the group

$$H = \langle x, y \mid x^3 = y^5 = (xy)^2 \rangle.$$

- (c) Show that  $H$  is a finite group. □

**Exercise 6.20.** Suppose  $M$  is a compact, orientable smooth 3-dimensional manifold whose integral homology is isomorphic to the homology of  $S^3$  and  $f : M \rightarrow \mathbb{R}$  is a Morse function.

- (a) Prove that  $f$  has an even number of critical points.  
 (b) Construct a Morse function on  $S^1 \times S^2$  that has exactly 4 critical points.  
 (c) A theorem of G. Reeb [Re] (see also [M1, M3]) states that  $M$  is homeomorphic to  $S^3$  if and only if there exists a Morse function on  $M$  with exactly two critical points. Prove that if  $H_\bullet(M, \mathbb{Z}) \cong H_\bullet(S^3, \mathbb{Z})$  but  $\pi_1(M) \neq \{1\}$  (e.g.,  $M$  is the Poincaré sphere), then any Morse function on  $M$  has at least 6 critical points. □

*Remark 6.21.* Part (c) is true under the weaker assumption that  $H_\bullet(M, \mathbb{Z}) \cong H_\bullet(S^3, \mathbb{Z})$  but  $M$  is not homeomorphic to  $S^3$ . This follows from Poincaré's conjecture whose validity was recently established by G. Perelman, which shows that  $M \cong S^3 \iff \pi_1(M) = \{1\}$ . However, this result is not needed in proving the stronger version of (c). One immediate conclusion of this exercise is that the manifold  $M$  *does not admit perfect Morse functions!!!* □

**Exercise 6.22.** Consider a knot  $K$  in  $\mathbb{R}^3$ , i.e., a smoothly embedded circle  $S^1 \hookrightarrow \mathbb{R}^3$ . Suppose there exists a unit vector  $u \in \mathbb{R}^3$  such that the function

$$\ell_u : K \rightarrow \mathbb{R}, \quad \ell_u(x) = (u, x) = \text{inner product of } u \text{ and } x$$

is a function with only two critical points, a global minimum and a global maximum. Prove that  $K$  must be the unknot. In particular, we deduce that the restriction of any linear function on a *nontrivial* knot in  $\mathbb{R}^3$  must have more than two critical points!

**Exercise 6.23.** Construct a Morse function  $f : S^2 \rightarrow \mathbb{R}$  with the following properties:

- (a)  $f$  is nonresonant, i.e., no level set  $\{f = \text{const}\}$  contains more than one critical point.
- (b)  $f$  has at least four critical points.
- (c) There exist orientation preserving diffeomorphisms  $R : S^2 \rightarrow S^2$ ,  $L : \mathbb{R} \rightarrow \mathbb{R}$  such that

$$-f = L \circ f \circ R. \quad \square$$

**Exercise 6.24 (Harvey–Lawson).** Consider the unit sphere

$$S^2 = \{(x, y, z) \in \mathbb{R}^3; x^2 + y^2 + z^2 = 1\}$$

and the smooth function  $f : S^2 \rightarrow \mathbb{R}$ ,  $f(x, y, z) = z$ . Denote by  $N$  the north pole  $N = (0, 0, 1)$ .

- (a) Find the critical points of  $f$ .
- (b) Denote by  $g$  the Riemannian metric on  $S^2$  induced by the canonical Euclidean metric  $g_0 = dx^2 + dy^2 + dz^2$  on  $\mathbb{R}^3$ . Denote by  $\omega_g$  the volume form on  $S^2$  induced by  $g$  and the orientation of  $S^2$  as boundary<sup>2</sup> of the unit ball. Describe  $g$  and  $\omega_g$  in cylindrical coordinate  $(\theta, z)$  (see Figure 6.1):

$$x = r \cos \theta, \quad y = r \sin \theta, \quad r = \sqrt{1 - z^2}, \quad \theta \in [0, 2\pi], \quad z \in [-1, 1].$$

- (c) Denote by  $\nabla f$  the gradient of  $f$  with respect to the metric  $g$ . Describe  $\nabla f$  in the cylindrical coordinates  $(\theta, z)$  and then describe the negative gradient flow

$$\frac{dp}{dt} = -\nabla f(p) \quad (6.1)$$

as a system of ODEs of the type

$$\begin{cases} \dot{\theta} = A(\theta, z) \\ \dot{z} = B(\theta, z) \end{cases},$$

<sup>2</sup> We are using the *outer-normal-first* convention.



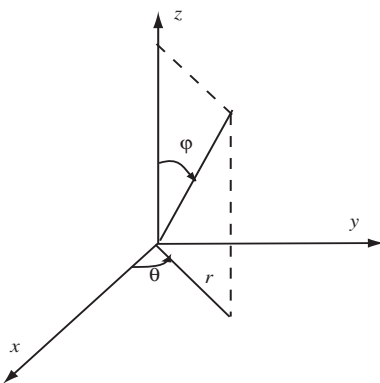

**Fig. 6.1.** Cylindrical coordinates.

where  $A, B$  are smooth functions of two variables, and the dot denotes differentiation with respect to the time variable  $t$ .

(d) Solve the system of ODEs found at (c).

(e) Denote by  $\Phi_t : S^2 \rightarrow S^2$ ,  $t \in \mathbb{R}$ , the one parameter group of diffeomorphisms of  $S^2$  determined by the gradient flow<sup>3</sup> (6.1) and set  $\omega_t := \Phi_t^* \omega_g$ . Show that for every  $t \in \mathbb{R}$  we have

$$\int_{S^2} \omega_t = \int_{S^2} \omega_g$$

and there exists a smooth function  $\lambda_t : S^2 \rightarrow (0, \infty)$  that depends only on the coordinate  $z$  such that

$$\omega_t = \lambda_t \cdot \omega_g, \quad \lim_{t \rightarrow \infty} \lambda_t(p) = 0, \quad \forall p \in S^2 \setminus N.$$

Sketch the graph of the function  $\lambda_t$  for  $|t|$  very large.

(f) Show that for every smooth function  $u : S^2 \rightarrow \mathbb{R}^2$  we have

$$\lim_{t \rightarrow \infty} \int_{S^2} u \cdot \omega_t = u(N) \int_{S^2} \omega_g \tag{6.2}$$

and then give a geometrical interpretation of the equality (6.2). □

**Exercise 6.25.** Prove the equality (3.3). □

**Exercise 6.26.** Suppose  $V$  is a finite dimensional real Euclidean space. We denote the inner product by  $(\bullet, \bullet)$ . We define an inner product on the space  $\text{End}(V)$  of endomorphisms of  $V$  by setting

<sup>3</sup> In other words, for every  $p \in S^2$  the path  $t \mapsto \Phi_t(p)$  is a solution of (6.1).

$$\langle S, T \rangle := \operatorname{tr}(ST^*).$$

Denote by  $SO(V) \subset \operatorname{End}(V)$  the group of orthogonal endomorphisms of determinant one, by  $\operatorname{End}_+(V)$  the subspace of symmetric endomorphisms, and by  $\operatorname{End}_-(V)$  the subspace of skew-symmetric endomorphisms.

(a) Show that  $\operatorname{End}_-(V)$  is the orthogonal complement of  $\operatorname{End}_+(V)$  with respect to the inner product  $\langle \bullet, \bullet \rangle$ .

(b) Let  $A \in \operatorname{End}_+(V)$  be a symmetric endomorphism with distinct *positive* eigenvalues. Define

$$f_A : SO(V) \rightarrow \mathbb{R}, \quad T \mapsto -\langle A, T \rangle.$$

Show that  $f_A$  is a Morse function with  $2^{n-1}$  critical points, where  $n = \dim V$  and then compute their indices.

(c) Show that the Morse polynomial of  $f_A$  is

$$P_n(t) = (1+t) \cdots (1+t^{n-1}). \quad \square$$

*Remark 6.27.* As explained in [Ha, Theorem 3D.2] the polynomial

$$(1+t) \cdots (1+t^{n-1})$$

is the Poincaré polynomial of  $SO(n)$  with  $\mathbb{Z}/2$  coefficients. This shows that the function  $f_A$  is a  $\mathbb{Z}/2$ -perfect Morse function.  $\square$

**Exercise 6.28.** Let  $V$  and  $A \in \operatorname{End}(V)$  be as in Exercise 6.26. For every  $S \in SO(V)$  we have an isomorphism

$$T_S SO(V) \rightarrow T_{\mathbb{1}} SO(V), \quad X \mapsto XS^{-1}.$$

We have a natural metric  $g$  on  $SO(V)$  induced by the metric  $\langle \bullet, \bullet \rangle$  on  $\operatorname{End}(V)$ .

(a) Show that for every  $S \in SO(V)$  we have

$$2\nabla^g f_A(S) = -A^* + ASA.$$

(b) Show that the Cayley transform

$$X \mapsto \mathcal{Y}(X) := (\mathbb{1} - X)(\mathbb{1} + X)^{-1}$$

defines a bijection from the open neighborhood  $\mathcal{U}$  of  $\mathbb{1} \in SO(V)$  consisting of orthogonal transformations  $S$  such that  $\det(\mathbb{1} + S) \neq 0$  to the open neighborhood  $\mathcal{O}$  of  $0 \in \operatorname{End}_-(V)$  consisting of skew-symmetric matrices  $Y$  such that  $\det(\mathbb{1} + Y) \neq 0$ .

(c) Suppose  $S_0$  is a critical point of  $f_A$ . Set  $\mathcal{U}_{S_0} = \mathcal{U}_{S_0}$ . Then  $\mathcal{U}_{S_0}$  is an open neighborhood of  $S_0 \in SO(V)$ , and we get a diffeomorphism

$$\mathcal{Y}_{S_0} : \mathcal{U}_{S_0} \rightarrow \mathcal{O}, \quad \mathcal{U}_{S_0} \ni T \mapsto \mathcal{Y}(TS_0^{-1}),$$

Thus we can regard the map  $\mathcal{Y}_{S_0}$  as defining local coordinates  $Y$  near  $S_0$ . Show that in these local coordinates the gradient flow of  $f_A$  has the description

$$\dot{Y} = AS_0Y - YAS_0.$$

(d) Show that for every orthogonal matrix  $S_0$ , the flow line through  $S_0$  of the gradient vector field  $2\nabla^g f_A$  is given by

$$t \mapsto \left( \sinh(-At) + \cosh(-At)S_0 \right) \left( \cosh(-At) + \sinh(-At)S_0 \right)^{-1}. \quad \square$$

**Exercise 6.29.** Suppose  $V$  is a finite dimensional complex Hermitian vector space of dimension  $n$ . We denote the Hermitian metric by  $(\bullet, \bullet)$ , the corresponding norm by  $|\bullet|$ , and the unit sphere by  $S = S(V)$ . For every integer  $0 < k < \dim V$  we denote by  $G_k(V)$  the Grassmannian of complex  $k$ -dimensional subspaces in  $V$ . For every  $L \in G_k(V)$  we denote by  $P_L : V \rightarrow V$  the orthogonal projection onto  $L$  and by  $L^\perp$  the orthogonal complement. We topologize  $G_k(V)$  using the metric

$$d(L_1, L_2) = \|P_{L_1} - P_{L_2}\|.$$

Suppose  $L \in G_k(V)$  and  $S : L \rightarrow L^\perp$  is a linear map. Denote by  $\Gamma_S \in G_k(V)$  the graph of the operator  $S$ , i.e., the subspace

$$\Gamma_S = \{x + Sx; x \in L\} \subset L \oplus L^\perp = V.$$

We thus have a map

$$\text{Hom}(L, L^\perp) \ni S \mapsto \Gamma_S \in G_k(V).$$

(a) Show that for every  $S \in \text{Hom}(L, L^\perp)$  we have

$$\Gamma_S^\perp = \{-y + S^*y; y \in L^\perp\} \subset L^\perp \oplus L,$$

where  $S^* : L^\perp \rightarrow L$  is the adjoint operator.

(b) Describe  $P_{\Gamma_S}$  in terms of  $P_L$  and  $S$ . For  $t \in \mathbb{R}$  set  $L_t = \Gamma_{tS}$ . Compute  $\frac{d}{dt}|_{t=0} P_{L_t}$ .

(c) Prove that the map

$$\text{Hom}(L, L^\perp) \ni S \mapsto \Gamma_S \in G_k(V)$$

is a homeomorphism onto the *open* subset of  $G_k(V)$  consisting of all  $k$ -planes intersecting  $L^\perp$  transversally. In particular, its inverse defines local coordinates on  $G_k(V)$  near  $L = \Gamma_{S=0}$ . We will refer to these as *graph coordinates*.

(d) Show that for every  $L \in G_k(V)$  the tangent space  $T_L G_k(V)$  is isomorphic to the space of symmetric operators  $\dot{P} : V \rightarrow V$  satisfying

$$\dot{P}(L) \subset L^\perp, \quad \dot{P}L^\perp \subset L.$$

Given  $\dot{P}$  as above, construct a linear operator  $S : L \rightarrow L^\perp$  such that

$$\left. \frac{d}{dt} \right|_{t=0} P_{\Gamma_{tS}} = \dot{P}. \quad \square$$

**Exercise 6.30.** Assume that  $A : V \rightarrow V$  is a Hermitian operator with simple eigenvalues. Define

$$h_A : G_k(V) \rightarrow \mathbb{R}, \quad h_A(T) = -\mathbf{Re} \operatorname{tr} AP_L.$$

- (a) Show that  $L$  is a critical point of  $h_A$  if and only if  $AL \subset L$ .  
 (b) Show that  $h_A$  is a perfect Morse function and then compute its Morse polynomial.  $\square$

*Remark 6.31.* The stable and unstable manifolds of the gradient flow of  $h_A$  with respect to the metric  $g(\dot{P}, \dot{Q}) = \mathbf{Re} \operatorname{tr}(\dot{P}, \dot{Q})$  coincide with some classical objects, the Schubert cycles of a complex Grassmannian.  $\square$

**Exercise 6.32.** Show that the gradient flow the function  $f_A$  in (3.4) is given by (3.5). Use this to conclude that  $f_A$  is Morse-Bott.

**Exercise 6.33.** Suppose  $V$  is an  $n$ -dimensional real Euclidean space with inner product  $(\bullet, \bullet)$  and  $A : V \rightarrow V$  is a selfadjoint endomorphism. We set

$$S(V) := \{ v \in V; |v| = 1 \}$$

and define

$$f_A : S(V) \rightarrow \mathbb{R}, \quad f_A(v) = (Av, v).$$

For  $1 \leq k \leq n = \dim V$  we denote by  $G_k(V)$  the Grassmannian of  $k$ -dimensional vector subspaces of  $V$  and we set

$$\lambda_k = \lambda_k(A) := \min_{E \in G_k(V)} \max_{v \in E \cap S(V)} f_A(v).$$

Show that

$$\lambda_1(A) \leq \lambda_2(A) \leq \cdots \leq \lambda_n(A)$$

and that any critical value of  $f_A$  is equal to one of the  $\lambda_k$ 's.  $\square$

**Exercise 6.34.** Prove Proposition 4.15.  $\square$

**Exercise 6.35.** Prove Lemma 4.11.  $\square$

**Exercise 6.36.** Prove Lemma 4.19. □

**Exercise 6.37.** Prove the claims in Example 4.23(c), (d). □

**Exercise 6.38.** Prove Proposition 4.24. □

**Exercise 6.39.** Prove Proposition 4.38. □

**Exercise 6.40.** Suppose  $V$  is a vector space equipped with a symplectic pairing

$$\omega : V \times V \rightarrow \mathbb{R}.$$

Denote by  $I_\omega : V \rightarrow V^*$  the induced isomorphism. For every subspace  $L \subset V$  we define its *symplectic annihilator* to be

$$L^\omega := \{v \in V; \omega(v, x) = 0 \ \forall x \in L\}.$$

(a) Prove that

$$I_\omega L^\omega = L^\perp = \{\alpha \in V^*; \langle \alpha, v \rangle = 0, \ \forall v \in L\}.$$

Conclude that  $\dim L + \dim L^\omega = \dim V$ .

(b) A subspace  $L \subset V$  is called *isotropic* if  $L \subset L^\omega$ . An isotropic subspace is called *Lagrangian* if  $L = L^\omega$ . Show that if  $L$  is an isotropic subspace then

$$0 \leq \dim L \leq \frac{1}{2} \dim V$$

with equality if and only if  $L$  is lagrangian.

(c) Suppose  $L_0, L_1$  are two Lagrangian subspaces of  $V$  such that  $L_0 \cap L_1 = (0)$ . Show that the following statements are equivalent.

(c1)  $L$  is a Lagrangian subspace of  $V$  transversal to  $L_1$ .

(c2) There exists a linear operator  $A : L_0 \rightarrow L_1$  such that

$$L = \{x + Ax; \ x \in L_0\}$$

and the bilinear form

$$Q : L_0 \times L_0 \rightarrow \mathbb{R}, \quad Q(x, y) = \omega(x, Ay)$$

is symmetric. We will denote it by  $Q_{L_0, L_1}(L)$ .

(d) Show that if  $L$  is a Lagrangian intersecting  $L_1$  transversally, then  $L$  intersects  $L_0$  transversally if and only if the symmetric bilinear form  $Q_{L_0, L_1}(L)$  is nondegenerate. □

**Exercise 6.41.** Consider a smooth  $n$ -dimensional manifold  $M$ . Denote by  $E$  the total space of the cotangent bundle  $\pi : T^*M \rightarrow M$  and by  $\theta = \theta_M$  the canonical 1-form on  $E$  described in local coordinates  $(\xi_1, \dots, \xi_m, x^1, \dots, x^m)$  by

$$\theta = \sum_i \xi_i dx^i.$$

Let  $\omega = -d\theta$  denote the canonical symplectic structure on  $E$ . A submanifold  $L \subset E$  is called *Lagrangian* if for every  $x \in L$  the tangent subspace  $T_x L$  is a Lagrangian subspace of  $T_x E$ .

(a) A smooth function  $f$  on  $M$  defines a submanifold  $\Gamma_{df}$  of  $E$ , the graph of the differential. In local coordinates  $(\xi_i; x^j)$  it is described by

$$\xi_i = \partial_{x^i} f(x).$$

Show that  $\Gamma_{df}$  is a Lagrangian submanifold of  $E$ .

(b) Suppose  $x \in M$  is a critical point of  $M$ . We regard  $M$  as a submanifold of  $E$  embedded as the zero section of  $T^*M$ . We identify  $x \in M$  with  $(0, x) \in T^*M$ . Set

$$L_0 = T_x^M \subset T_{(0,x)}E, \quad L_1 = T_x^*M \subset T_{(0,x)}E, \quad L = T_{(0,x)}\Gamma_{df} \subset T_{(0,x)}E.$$

They are all Lagrangian subspaces of  $V = T_{(0,x)}E$ . Clearly  $L_0 \pitchfork L_1$  and  $L \pitchfork L_1$ . Show that

$$Q_{L_0, L_1}(L) = \text{the Hessian of } f \text{ at } x \in M. \quad (6.3)$$

(c) A Lagrangian submanifold  $L$  of  $E$  is called *exact* if the restriction of  $\theta$  to  $L$  is exact. Show that  $\Gamma_{df}$  is an exact Lagrangian submanifold.

(d) Suppose  $H$  is a smooth real valued function on  $E$ . Denote by  $X_H$  the Hamiltonian vector field associated with  $H$  and the symplectic form  $\omega = -d\theta$ . Show that in the local coordinates  $(\xi_i, x^j)$  we have

$$X_H = \sum_i \frac{\partial H}{\partial \xi_i} \partial_{x^i} - \sum_j \frac{\partial H}{\partial x^j} \partial_{\xi_j}.$$

Show that if  $L$  is an exact Lagrangian submanifold of  $E$ , then so is  $\Phi_t^H(L)$  for any  $t \in \mathbb{R}$ .  $\square$

**Exercise 6.42.** We fix a diffeomorphism

$$\mathbb{R} \times S^1 \rightarrow T^*S^1, \quad (\xi, \theta) \mapsto (\xi d\theta, \theta),$$

so that the canonical symplectic form on  $T^*S^1$  is given by

$$\omega = d\theta \wedge d\xi.$$

Denote by  $L_0 \subset T^*S^1$  the zero section.

- (a) Construct a compact Lagrangian submanifold of  $T^*S^1$  that does not intersect  $L_0$ .  
 (b) Show that any compact, *exact Lagrangian*, oriented submanifold  $L$  of  $T^*S^1$  intersects  $L_0$  in at least two points.  $\square$

*Remark 6.43.* The above result is a very special case of Arnold's conjecture stating that if  $M$  is a compact smooth manifold then any exact Lagrangian submanifold  $T^*M$  must intersect the zero section in at least as many points as the number of critical points of a smooth function on  $M$ . In particular, if an exact Lagrangian intersects the zero section transversally, then the geometric number of intersection points is no less than the sum of Betti numbers of  $M$ .  $\square$

**Exercise 6.44.** Consider the tautological right action of  $SO(3)$  on its cotangent bundle

$$T^*SO(3) \times SO(3) \ni (\varphi, h; g) \mapsto (R_{g^{-1}}^* \varphi, R_g(h) = hg),$$

where

$$R_{g^{-1}}^* : T_{gh}SO(3) \rightarrow T_hSO(3)$$

is the pullback map. Show that this action is Hamiltonian with respect to the tautological symplectic form on  $T^*SO(3)$  and then compute its moment map

$$\mu : T^*SO(3) \rightarrow \mathfrak{so}(3)^*. \quad \square$$

**Exercise 6.45.** Consider the complex projective space  $\mathbb{C}\mathbb{P}^n$  with projective coordinates  $\mathbf{z} = [z^0, \dots, z^n]$ .

- (a) Show that the Fubini–Study form

$$\omega = i\partial\bar{\partial} \log |\mathbf{z}|^2, \quad |\mathbf{z}|^2 = \sum_{k=0}^n |z_k|^2$$

defines a symplectic structure on  $\mathbb{C}\mathbb{P}^n$ .

- (b) Show that the action of  $S^1$  on  $\mathbb{C}\mathbb{P}^n$  given by

$$e^{it} \cdot [z_0, \dots, z_n] = [z^0, e^{it} z_1, e^{2it} z_2, \dots, e^{nit} z_n]$$

is Hamiltonian and then find a moment map for this action.  $\square$

**Exercise 6.46.** Let  $(M, \omega)$  be a compact toric manifold of dimension  $2n$  and denote by  $\mathbb{T}$  the  $n$ -dimensional torus acting on  $M$ .

- (a) Prove that the top dimensional orbits of  $\mathbb{T}$  are Lagrangian submanifolds.  
 (b) Prove that the set of points in  $M$  with trivial stabilizers is open and dense.  $\square$

**Exercise 6.47.** (a) Let  $\mathbb{T}$  be a compact torus of real dimension  $n$  with Lie algebra  $\mathfrak{t}$ . A *character* of  $\mathbb{T}^n$  is by definition a continuous group morphism  $\chi : \mathbb{T} \rightarrow S^1$ . We denote by  $\hat{\mathbb{T}}$  set of characters of  $\mathbb{T}$ . Then  $\hat{\mathbb{T}}$  is an Abelian group with respect to the operation

$$(\chi_1 \cdot \chi_2)(t) := \chi_1(t) \cdot \chi_2(t), \quad \forall t \in \mathbb{T}, \quad \chi_1, \chi_2 \in \hat{\mathbb{T}}.$$

(a) Show that the natural map

$$(\hat{\mathbb{T}}, \cdot) \ni \chi \longmapsto (d\chi)|_{t=1} \in (\mathfrak{t}^*, +)$$

is an injective group morphism whose image is a *lattice* of  $\mathfrak{t}^*$ , i.e., it is a free Abelian group of rank  $n$  that spans  $\mathfrak{t}^*$  as a vector space. We denote this lattice by  $\Lambda$ .

(b) Consider the dual lattice

$$\Lambda^\vee := \text{Hom}_{\mathbb{Z}}(\Lambda, \mathbb{Z}) \subset \mathbb{T},$$

Show that  $\Lambda^\vee$  is a lattice in  $\mathfrak{t}$  and

$$\mathbb{T} \cong \mathfrak{t}/\Lambda^\vee.$$

(c) There exists a unique translation invariant measure  $\lambda$  on  $\mathfrak{t}$  such that the volume of the quotient  $\mathbb{T} := \mathfrak{t}/\Lambda^\vee$  is equal to 1. Equivalently,  $\lambda$  is the Lebesgue measure on  $\mathbb{T}$  normalized by the requirement that the volume of the fundamental parallelepiped of  $\Lambda^\vee$  be equal to 1. Suppose we are given an *effective* Hamiltonian action of  $\mathbb{T}$  of a compact symplectic manifold  $(M, \omega)$  of dimension  $2n = 2 \dim \mathbb{T}$ . Denote by  $\mu$  a moment map of this action. Show that

$$\int_M \frac{1}{n!} \omega^n = \text{vol}_\lambda(\mu(M)). \quad \square$$

**Exercise 6.48.** Prove that there exists no smooth effective action of  $S^1$  on a compact oriented Riemann surface  $\Sigma$  of genus  $g \geq 2$ .  $\square$

**Exercise 6.49.** Let  $G = \{\pm 1\}$  denote the (multiplicative) cyclic group of order two, and  $\mathbb{F}_2$  denote the field with two elements. Then  $G$  acts on  $S^\infty$  by reflection in the center of the sphere. The quotient is the infinite dimensional real projective space  $\mathbb{RP}^\infty$ . The cohomology ring of  $\mathbb{RP}^\infty$  with coefficients in  $\mathbb{F}_2$  is

$$H^\bullet(\mathbb{RP}^\infty, \mathbb{F}_2) \cong R := \mathbb{F}_2[t], \quad \deg t = 1.$$

For every continuous action of  $G$  on a locally compact space  $X$  we set

$$X_G := (S^\infty \times X)/G,$$

where  $G$  acts by



$$t \cdot (v, x) = (t \cdot v, t^{-1}x), \quad \forall t \in G, \quad v \in S^\infty, \quad x \in X.$$

Set

$$H_G(X) := H^\bullet(X_G, \mathbb{F}_2).$$

Observe that we have a fibration

$$X \hookrightarrow X_G \rightarrow \mathbb{R}\mathbb{P}^\infty,$$

and thus  $H_G(X)$  has a natural structure of an  $R$ -module. Similarly, if  $Y$  is a closed,  $G$ -invariant subset of  $X$  we define

$$H_G(X, Y) := H^\bullet(X_G, Y_G; \mathbb{F}_2).$$

A *finitely generated*  $R$ -module  $M$  is called *negligible* if the  $\mathbb{F}_2$ -linear endomorphism

$$t : M \rightarrow M, \quad m \mapsto t \cdot m,$$

is nilpotent.

(a) Show that if  $G$  acts freely on the compact space  $X$  then  $H_G(X)$  is negligible.

(b) Suppose  $X$  is a compact smooth manifold and  $G$  acts smoothly on  $X$ . Denote by  $\text{Fix}_G(X)$  the fixed point set of this action. Show that  $F$  is a compact smooth manifold. Show that  $H_G(X, \text{Fix}_G(X))$  is negligible.

(c) Prove that

$$\sum_{k \geq 0} \dim_{\mathbb{F}_2} H^k(\text{Fix}_G(X), \mathbb{F}_2) \leq \sum_{k \geq 0} \dim_{\mathbb{F}_2} H^k(X, \mathbb{F}_2). \quad \square$$

**Exercise 6.50.** Consider a homogeneous polynomial  $P \in \mathbb{R}[x, y, z]$  of degree  $d$ . Define

$$X(P) := \{ [x, y, z] \in \mathbb{R}\mathbb{P}^2; \quad P(x, y, z) = 0 \}.$$

For generic  $P$ , the locus  $X(P)$  is a smooth submanifold of  $\mathbb{R}\mathbb{P}^2$  of dimension 1, i.e.,  $X(P)$  is a disjoint union of circles (ovals). Denote by  $n(P)$  the number of these circles. Show that

$$n(P) \leq 1 + \frac{(d-1)(d-2)}{2}. \quad \square$$

**Exercise 6.51.** Prove Lemma 3.89. □

**Exercise 6.52.** Suppose  $M$  is a compact, connected, orientable, smooth manifold without boundary. Set  $m := \dim M$ . Fix an orientation  $\mathbf{or}$  on  $M$ . Denote by  $H^\bullet(M)$  the De Rham cohomology of  $M$ . For  $0 \leq k \leq m$  we set

$$H_k(M) := \text{Hom}(H^k(M), \mathbb{R}).$$

The *Kronecker pairing*

$$\langle -, - \rangle : H^k(M) \times H_k(M) \rightarrow \mathbb{R}, \quad H^k(M) \times H_k(M) \ni (\alpha, z) \mapsto \langle \alpha, z \rangle$$

is the natural pairing between a vector space and its dual.

The orientation  $\mathbf{or}_M$  determines an element  $[M] \in H_m(M)$  via

$$\langle \alpha, [M] \rangle := \int_M \eta_\alpha,$$

where  $\eta_\alpha$  denotes an  $m$ -form on  $M$  whose De Rham cohomology class is  $\alpha$ .

Observe that we have a natural map

$$PD : H^{m-k}(M) \rightarrow H_k(M),$$

so that for  $\alpha \in H^{m-k}(M)$  the element  $PD(\alpha) \in H_k(M)$  is defined by

$$\langle \beta, PD(\alpha) \rangle := \langle \alpha \cup \beta, [M] \rangle.$$

The Poincaré duality theorem states that this map is an isomorphism.

A smooth map  $\phi : M \rightarrow M$  induces a linear map  $\phi_* : H_\bullet(M) \rightarrow H_\bullet(M)$  defined by the commutative diagram

$$\begin{array}{ccc} H^\bullet(M) & \xrightarrow{\phi^*} & H^\bullet(M) \\ PD \downarrow & & \downarrow PD \\ H_\bullet(M) & \xrightarrow[\phi_*]{\text{-----}} & H_\bullet(M) \end{array} .$$

(a) Show that if  $\phi$  is a diffeomorphism, then for every  $\alpha \in H^\bullet(M)$  and every smooth map  $\phi$  of  $M$  we have

$$\phi_*(PD\alpha) = (\text{deg } \phi) \cdot PD((\phi^{-1})^*\alpha).$$

(b) Suppose  $S$  is a compact *oriented* submanifold of  $M$  of dimension  $k$ . Then  $S$  determines an element  $[S]$  of  $H_k(M)$  via

$$\langle \alpha, [S] \rangle = \int_S \eta_\alpha, \quad \forall \alpha$$

where  $\eta_\alpha$  denotes a closed  $k$ -form representing the De Rham cohomology class  $\alpha$ . Any diffeomorphism  $\phi : M \rightarrow M$  determines a new *oriented* submanifold  $\phi(S)$  in an obvious fashion. Show that

$$\phi_*[S] = [\phi(S)]. \quad \square$$

**Exercise 6.53.** Consider two homogeneous cubic polynomials in the variables  $(z_0, z_1, z_2)$ . The equation

$$t_0^n A_0(z_0, z_1, z_2) + t_1^n A_1(z_0, z_1, z_2) = 0$$

defines a hypersurface  $Y_n$  in  $\mathbb{P}^2 \times \mathbb{P}^1$ .

(a) Show that for generic  $A_0, A_1$  the hypersurface  $Y_n$  is smooth.

(b) Show that for generic  $A_0, A_1$  the natural map  $Y_n \rightarrow \mathbb{P}^1$  induced by the projection  $\mathbb{P}^2 \times \mathbb{P}^1 \rightarrow \mathbb{P}^1$  is a nonresonant Morse map.

(c) Show that for generic  $A_0, A_1$  the hypersurface  $Y_1$  is biholomorphic to the blowup of  $\mathbb{P}^2$  at the nine points of intersection of the cubic  $\{A_0 = 0\}$  and  $\{A_1 = 1\}$ . (See Example 5.5.)

(d) Using the computations in Example 5.15 deduce that for generic  $A_0, A_1$  the map  $X_n \rightarrow \mathbb{P}^1$  has precisely  $12n$  critical points. Conclude that

$$\chi(X_n) = 12n.$$

(e) Describe the above map  $X_n \rightarrow \mathbb{P}^1$  as a Lefschetz fibration (see Definition 5.2) using the *Segre embeddings*

$$\mathbb{P}^k \times \mathbb{P}^m \rightarrow \mathbb{P}^{(k+1)(m+1)-1},$$

$$\mathbb{P}^k \times \mathbb{P}^m \ni ([x_i]_{0 \leq i \leq k}, [y_j]_{0 \leq j \leq m}) \mapsto [x_i y_j]_{0 \leq i \leq k, 0 \leq j \leq m} \in \mathbb{P}^{(k+1)(m+1)-1}.$$

## 6.2 Solutions to Selected Exercises

**Exercise 6.6.** (a) The equality  $T_K = 2\pi$  and the identity (1.14) imply that for almost any unit vector  $\mathbf{v}$  the height function  $h_{\mathbf{v}}$  has only two critical points. Show that for such a function the sublevel sets  $\{h_{\mathbf{v}} \leq c\}$  are connected. Hence, for a *dense* collection of unit vectors  $\mathbf{v}$ , all the sublevel sets of  $h_{\mathbf{v}}$  are connected. To prove that this is true *for any*  $\mathbf{v}$  argue by contradiction using the above density.

(b) Use part (a) to show that for any three non-collinear points  $x, y, z \in K$  on  $K$  the plane determined by these three points intersects  $K$  along a connected set. Deduce from this that  $K$  is planar. Once  $K$  is planar, the convexity follows easily from the equality  $T_K = 2\pi$  and (a).  $\square$

**Exercise 6.8.** Fix an arclength parametrization  $[0, L] \ni s \mapsto \mathbf{x}(s) \in K$ , where  $L$  is the length of  $K$ . Define

$$\mathcal{J}_K := \{(\mathbf{x}, A) \in K \times \mathcal{S}_1; A\mathbf{x} \perp T_{\mathbf{x}}K\}.$$

Show that  $\mathcal{J}$  is a two-dimensional smooth submanifold of  $K \times \mathcal{S}_1$ . Denote by  $g_K$  the induced metric. The submanifold  $\mathcal{J}_K$  comes with two natural smooth maps

$$K \xleftarrow{\lambda_K} \mathcal{J}_K \xrightarrow{\rho_K} \mathcal{S}_1.$$

Denote by  $|J_K|$  the Jacobian of  $\rho_K$ . The area formula implies

$$\int_{\mathcal{S}_1} N_K(A) dS(A) = \int_{\mathcal{J}_K} |J_K| dV_{g_K}.$$

The second integral can be computed using Fubini's theorem. Here are some details. Consider the oriented Frenet frame  $(\mathbf{x}'(s), \mathbf{n}(s))$  along  $K$ , and decompose  $\mathbf{s}$  along this frame

$$\mathbf{x}(s) = \alpha(s)\mathbf{x}'(s) + \beta(s)\mathbf{n}(s).$$

Note that since  $0 \notin K$  we have

$$\alpha(s)^2 + \beta(s)^2 \neq 0.$$

For any  $\theta \in [0, 2\pi]$  denote by  $A(s, \theta) \in \mathcal{S}_1$  the symmetric linear transformation of  $\mathbb{R}^2$  which with respect to the Frenet frame is represented by the matrix

$$\begin{bmatrix} -c\beta(s) & c\alpha(s) \\ c\alpha(s) & \sin \theta \end{bmatrix},$$

where  $c$  is determined by the equality  $\text{tr } A(s, \theta)^2 = 1$ , i.e.,

$$c\sqrt{2\alpha(s)^2 + \beta(s)^2} = \cos \theta \iff c = c(s, \theta) = \frac{\cos \theta}{\sqrt{2\alpha(s)^2 + \beta(s)^2}}.$$

Denote by  $(\mathbf{e}_1, \mathbf{e}_2)$  the canonical basis of  $\mathbb{R}^2$ . We can write

$$\mathbf{x}'(s) = \cos \phi(s)\mathbf{e}_1 + \sin \phi(s)\mathbf{e}_2.$$

Denote by  $R_{\phi(s)}$  the counterclockwise rotation of  $\mathbb{R}^2$  of angle  $\phi(s)$ . With respect to the frame  $(\mathbf{e}_1, \mathbf{e}_2)$  the linear map  $A(s, \theta)$  is represented by the matrix

$$T(s, \theta) = R_{\phi(s)} \begin{bmatrix} -c\beta(s) & c\alpha(s) \\ c\alpha(s) & \sin \theta \end{bmatrix} R_{-\phi(s)}$$

The map

$$\mathbb{R}/L\mathbb{Z} \times \mathbb{R}/2\pi\mathbb{Z} \ni (s, \theta) \mapsto (x(s), T(s, \theta), ) \in K \times \mathcal{S}_1. \quad (6.4)$$

is a diffeomorphism onto  $\mathcal{J}_K$ . The volume form  $dV_{g_K}$  can be written as

$$dV_{g_K} = w_K(s, \theta) ds d\theta,$$

where  $w_K(s, \theta)$  is a positive function that can be determined explicitly from (6.4). In the coordinates  $(s, \theta)$  the map  $\rho_K$  takes the form

$$(s, \theta) \mapsto T(s, \theta), \quad (6.5)$$

while the map  $\lambda_K$  takes the form  $(s, \theta) \mapsto s$ . The equality (6.5) can be used to determine the Jacobian  $|J_K|(s, \theta)$  of  $\rho_K$ . We deduce that

$$\int_{S_1} N_K(A) dS_A = \int_0^L \left( \int_0^{2\pi} |J_K|(s, \theta) w_K(s, \theta) d\theta \right) ds. \quad \square$$

**Exercise 6.12.** Let  $x \in X$  and  $s = f(x)$ . Set

$$U = T_x X, \quad V = T_s S, \quad W = T_s Y, \quad T = Df : U \rightarrow V, \quad R = \text{range } T.$$

For every subspace  $E \subset W$  we denote by  $E^\perp \subset W^*$  its annihilator in  $W^*$ ,

$$E^\perp := \{w \in W^*; \langle w, e \rangle = 0, \forall e \in E\}.$$

We have

$$f \text{ transversal to } S \iff R + V = W \iff (R + V)^\perp = 0.$$

On the other hand,

$$(R + V)^\perp = R^\perp \cap V^\perp, \quad R^\perp = \ker T^*,$$

so that

$$\ker T^* \cap V^\perp = 0.$$

If  $u$  is a function on  $Y$  then  $du_s \in W^*$ . If  $u|_S = 0$  we deduce  $du_s \in V^\perp$ . Then

$$f^*(du)_x = T^*(du|_s)$$

and thus

$$f^*(du)_x = 0 \iff du_s \in \ker T^* \cap V^\perp = 0.$$

(b) Let  $c = \text{codim } S$ . Then  $S$  is defined near  $s \in S$  by an equality

$$u^1 = \dots = u^c = 0, \quad du^i|_s \text{ linearly independent in } T_s^* S,$$

and  $f^{-1}(S)$  is defined near  $x \in f^{-1}(S)$  by the equality

$$v^i = 0, \quad i = 1, \dots, c, \quad v^i - f^* u^i.$$

We have

$$\sum_i \lambda_i dv_x^i = 0, \quad \lambda^i \in \mathbb{R} \implies f^*(du)_x = 0, \quad u = \sum_i \lambda_i u^i,$$

and from part (a) we deduce  $du_s = 0 \in T_s^* S$ . Since  $du_s^i$  are linearly independent, we deduce  $\lambda_i = 0$ , and thus  $dv_x^i$  are linearly independent. From the implicit function theorem we deduce that  $f^{-1}(S)$  is a submanifold of codimension  $c$ .  $\square$

**Exercise 6.13.** Set

$$Z = \{(x, \lambda) \in X \times A; (\lambda, f_\lambda(x)) \in \tilde{S}\} = G^{-1}(\tilde{S}).$$

Denote by  $\zeta : Z \rightarrow A$  the restriction to  $Z$  of the natural projection  $X \times A \rightarrow A$  and let

$$Z_\lambda = \zeta^{-1}(\lambda) \cong \{x \in X; (x, \lambda) \in Z\} = f_\lambda^{-1}(S_\lambda).$$

Sard's theorem implies that there exists a negligible set  $A_0 \subset A$  such that for every  $\lambda \in A \setminus A_0$  either the fiber  $Z_\lambda$  is empty or for every  $(x, \lambda) \in Z_\lambda$  the differential

$$\zeta_* : T_{(x, \lambda)}Z \rightarrow T_\lambda A$$

is surjective. If  $Z_\lambda = \emptyset$ , then  $f_\lambda$  is tautologically transversal to  $S_\lambda$ .

Let  $(x_0, \lambda_0) \in Z$  such that  $\zeta_* : T_{(x_0, \lambda_0)}Z \rightarrow T_{\lambda_0}A$  is onto. Set  $(y_0, \lambda_0) = G(x_0, \lambda_0) \in \tilde{S}$ ,

$$\begin{aligned} \dot{X} &:= T_{x_0}X, & \dot{Y} &:= T_{y_0}Y, & \dot{A} &:= T_{\lambda_0}A, \\ \dot{S} &:= T_{(y_0, \lambda_0)}\tilde{S}, & \dot{S}_0 &:= T_{y_0}S_{\lambda_0}, & \dot{Z} &:= T_{(x_0, \lambda_0)}Z. \end{aligned}$$

Decompose the differential  $F_*$  of  $F$  at  $(x_0, \lambda_0)$  in partial differentials

$$A = D_\lambda F : \dot{A} \rightarrow \dot{Y}, \quad B = D_x F = D_x f_{\lambda_0} : \dot{X} \rightarrow \dot{Y}.$$

The transversality assumption on  $G$  implies that

$$\dot{Y} \oplus \dot{A} = \dot{S} + G_*(\dot{X} \oplus \dot{A}). \quad (6.6)$$

Observe that

$$\dot{S}_0 = \dot{S} \cap (\dot{Y} \oplus 0).$$

Moreover, our choice of  $(x_0, \lambda_0)$  implies that  $\zeta_* : \dot{Z} \subset \dot{X} \oplus \dot{A} \rightarrow \dot{A}$  is onto. We have to prove that

$$\dot{Y} = B(\dot{X}) + \dot{S}_0.$$

Let  $\dot{y}_0 \in \dot{Y}$ . We want to show that  $\dot{y}_0 \in B(\dot{X}) + \dot{S}_0$ . From (6.6) we deduce

$$\exists(\dot{x}_0, \dot{\lambda}_0) \in \dot{X} \oplus \dot{A}, \quad (\dot{y}_1, \dot{\lambda}_1) \in \dot{S}$$

such that

$$(\dot{y}_0, 0) = G_*(\dot{x}_0, \dot{\lambda}_0) + (\dot{y}_1, \dot{\lambda}_1) \iff (\dot{y}_0, 0) = (A\dot{\lambda}_0 + B\dot{x}_0, \dot{\lambda}_0) + (\dot{y}_1, \dot{\lambda}_1).$$

Thus  $\dot{\lambda}_1 = -\dot{\lambda}_0$  and  $(\dot{y}_1, -\dot{\lambda}_0) \in \dot{S}$  and

$$(\dot{x}_1, \dot{\lambda}_0) = (A\dot{\lambda}_0 + B\dot{x}_0, \dot{\lambda}_0) + \underbrace{(\dot{y}_1, -\dot{\lambda}_0)}_{\in \dot{S}}.$$

On the other hand,  $\dot{\lambda}_0$  lies in the image projection  $\zeta_* : \dot{Z} \rightarrow \dot{A}$ , so that  $\exists \dot{x}_1 \in \dot{X}$  such that  $(\dot{x}_1, \dot{\lambda}_0) \in \dot{Z}$ . Since  $G_*\dot{Z} \subset \dot{S}$ , we deduce

$$G_*(\dot{x}_1, \dot{\lambda}_0) \in \dot{S} \iff (A\dot{\lambda}_0 + B\dot{x}_1, \dot{\lambda}_0) \in \dot{S}.$$

Now we can write

$$\begin{aligned} (\dot{y}_0, 0) &= G_*\left((\dot{x}_0, \dot{\lambda}_0) - (\dot{x}_1, \dot{\lambda}_0)\right) + \underbrace{G_*(\dot{x}_1, \dot{\lambda}_0)}_{\in \dot{S}} + \underbrace{(\dot{y}_1, -\dot{\lambda}_0)}_{\in \dot{S}} \\ \iff (\dot{y}_0, 0) &= (B(\dot{x}_0 - \dot{x}_1), 0) + \underbrace{(B\dot{x}_1 + A\dot{\lambda}_0 + \dot{y}_1, 0)}_{\in \dot{S}_0}. \end{aligned}$$

This proves that  $\dot{y}_0 \in B(\dot{X}) + \dot{S}_0$ . □

**Exercise 6.15.** Let  $\mathbf{v} \in S^n$  and suppose  $x \in M$  is a critical point of  $\ell_{\mathbf{v}}$ . Modulo a translation we can assume that  $x = 0$ . We can then find an orthonormal basis  $(e_1, \dots, e_n, e_{n+1})$  with coordinate functions  $(x^1, \dots, x^{n+1})$  such that  $\mathbf{v} = e_{n+1}$ . From the implicit function theorem we deduce that near 0 the hypersurface  $M$  can be expressed as the graph of a smooth function

$$x^{n+1} = f(x), \quad x = (x^1, \dots, x^n), \quad df(0) = 0.$$

Thus  $(x^1, \dots, x^n)$  define local coordinates on  $M$  near 0. The function  $\ell_{\mathbf{v}}$  on  $M$  then coincides with the coordinate function  $x^{n+1} = f(x)$ .

Near  $e_{n+1} \in S^n = \{(y^1, \dots, y^{n+1}) \in \mathbb{R}^{n+1}; \sum_i |y^i|^2 = 1\}$  we can choose  $y = (y^1, \dots, y^n)$  as local coordinates. Observe that

$$\mathcal{N}_M(x) = \frac{1}{(1 + |\nabla f|^2)^{1/2}}(e_{n+1} - \nabla f).$$

In the coordinates  $x$  on  $M$  and  $y$  on  $S^n$  the Gauss map  $\mathcal{N}_M : M \rightarrow S^n$  is expressed by

$$\mathcal{N}_M(x) = -\frac{1}{(1 + |\nabla f|^2)^{1/2}}\nabla f.$$

For simplicity, we set  $g = -\nabla f$  and we deduce that

$$D_0\mathcal{N}_M : T_0M \rightarrow T_{e_{n+1}}S^{n+1}$$

is equal to

$$D\frac{1}{(1 + |g|^2)^{1/2}}g|_{x=0} = d\left(\frac{1}{(1 + |g|^2)^{1/2}}\right)g|_{x=0} + \frac{1}{(1 + |g|^2)^{1/2}}Dg|_{x=0}.$$

Since  $g(0) = 0$  and  $Dg|_{x=0} = -H_{f,0}$ , we conclude that

$$D_0\mathcal{N}_M = D\frac{1}{(1 + |g|^2)^{1/2}}g|_{x=0} = -\frac{1}{(1 + |g|^2)^{1/2}}H_{g,0}.$$

Hence  $0 \in M$  is a regular point of  $\mathcal{N}_M$  if and only if  $\det H_{h,0} \neq 0$ , i.e., 0 is a nondegenerate critical point of  $f$ . □

*Remark 6.54.* The differential of the Gauss map is called the *second fundamental form* of the hypersurface. The above computation shows that it is a symmetric operator. If we denote by  $\lambda_1, \dots, \lambda_n$  the eigenvalues of this differential at a point  $x \in M$ , then the celebrated *Theorema Egregium* of Gauss states that the symmetric combination  $\sum_{i \neq j} \lambda_i \lambda_j$  is the *scalar curvature* of  $M$  at  $x$  with respect to the metric induced by the Euclidean metric in  $\mathbb{R}^{n+1}$ . In particular, this shows that the local minima and maxima of  $\ell_{\mathbf{v}}$  are attained at points where the scalar curvature is positive.

If  $\Sigma$  is a *compact* Riemann surface embedded in  $\mathbb{R}^3$ , then  $\ell_{\mathbf{v}}$  has global minima and maxima and thus there exist points in  $\Sigma$  where the scalar curvature is positive. Hence, a compact Riemann surface equipped with a hyperbolic metric (i.e., scalar curvature =  $-2$ ) cannot be *isometrically* embedded in  $\mathbb{R}^3$ .  $\square$

**Exercise 6.16.** To prove the equality

$$m(u) = \frac{1}{4\pi} \int_U \mathbf{N}_{\Sigma}^* dV_{S^2}$$

use Exercise 6.15. The second equality follows from the classical identity, [Ni1, Example 4.2.14], [Str, Sections 4-8, p. 156]

$$\mathbf{N}_{\Sigma}^* dV_{S^2} = \frac{s}{2} dV_g.$$

$\square$

**Exercise 6.17.** See [BK, Section 4].  $\square$

**Exercise 6.20.** (a) Suppose  $f$  is a Morse function on  $M$ . Denote by  $P_f(t)$  its Morse polynomial. Then the number of critical points of  $f$  is  $P_f(1)$ . The Morse inequalities show that there exists  $Q \in \mathbb{Z}[t]$  with nonnegative coefficients such that

$$P_f(t) = P_M(t) + (1+t)Q(t). \quad (\dagger)$$

Since  $M$  is odd dimensional and orientable, we have  $\chi(M) = 0$  and we deduce

$$P_f(-1) = P_M(-1) = \chi(M) = 0.$$

Finally, note that

$$P_f(1) \equiv P_f(-1) \pmod{2} \implies P_f(1) \in 2\mathbb{Z}.$$

(b) For every  $n \geq 1$  denote by  $S^n$  the round sphere

$$S^n = \left\{ (x^0, \dots, x^n) \in \mathbb{R}^{n+1}; \sum_i |x^i|^2 = 1 \right\}.$$

The function  $h_n : S^n \rightarrow \mathbb{R}$ ,  $h_n(x^0, \dots, x^n) = x^n$  is a perfect Morse function on  $S^n$  because its only critical points are the north and south poles. Now consider the function



$$h_{n,m} : S^n \times S^m \rightarrow \mathbb{R}, \quad h_{n,m}(x, y) = h_n(x) + h_m(y).$$

One can check easily that

$$P_{h_{n,m}}(t) = P_{h_n}(t) \cdot P_{h_m}(t) = P_{S^n}(t) \cdot P_{h_m}(t) = P_{S^n \times S^m}(t).$$

(c) Suppose  $H_\bullet(M, \mathbb{Z}) \cong H_\bullet(S^3, \mathbb{Z})$  and  $f$  has fewer than 6 critical points, i.e.,  $P_f(1) < 6$ . Since  $P_f(1)$  is an even number, we deduce  $P_f(1) = 2, 4$ . On the other hand, the fundamental group of  $M$  is nontrivial and non Abelian. This means that any presentation of  $\pi_1(M)$  has to have at least two generators. In particular, any CW decomposition of  $M$  must have at least two cells of dimension 1. Hence the coefficient of  $t$  in  $P_f(t)$  must be at least two. Since  $f$  must have a maximum and a minimum, we deduce that the coefficients of  $t^0$  and  $t^3$  in  $P_f$  are strictly positive. Now using  $P_f(t) < 6$  we conclude that

$$P_f(t) = 1 + 2t + t^3.$$

However, in this case  $P_f(-1) = 1 - 3 \neq \chi(M)$ . □

**Exercise 6.22.** The range of  $\ell_u$  is a compact interval  $[m, M]$ , where

$$m = \min_K \ell_u, \quad M = \max_K \ell_u, \quad m < M.$$

Observe that for every  $t \in (m, M)$  the intersection of the hyperplane

$$\{(u, x) = t\}$$

with the knot  $K$  consists of precisely two points,  $B_0(t), B_1(t)$  (see Figure 6.2). The construction of the unknotting isotopy uses the following elementary fact.

Given a pair of distinct points  $(A_0, A_1) \in \mathbb{R}^2 \times \mathbb{R}^2$ , and any pair of continuous functions

$$B_0, B_1 : [0, 1] \rightarrow \mathbb{R}^2$$

such that

$$B_0(0) = A_0, \quad B_1(0) = A_1, \quad B_0(t) \neq B_1(t), \quad \forall t \in [0, 1],$$

there exist continuous functions

$$\lambda : [0, 1] \rightarrow (0, \infty), \quad S : [0, 1] \rightarrow SO(2)$$

such that  $\lambda(0) = 1$ ,  $S_0 = \mathbb{1}$  and for every  $t \in [0, 1]$  the affine map

$$T_t : \mathbb{R}^2 \rightarrow \mathbb{R}^2, \quad T_t(x) = B_0(t) + \lambda(t)S_t(x - A_0)$$

maps  $A_0$  to  $B_0(t)$  and  $A_1$  to  $B_1(t)$ .

To prove this elementary fact use the lifting properties of the universal cover of  $SO(2) \cong S^1$ . □

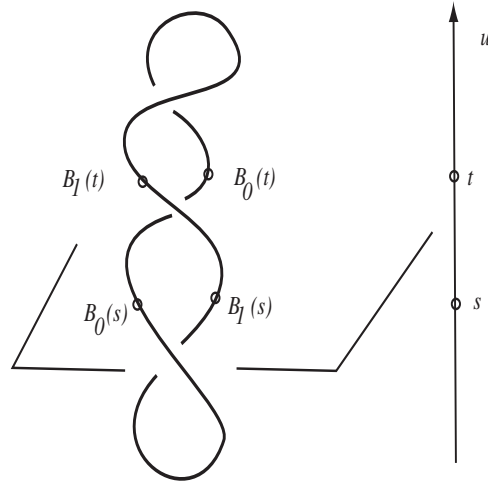

**Fig. 6.2.** Unwinding a garden hose.

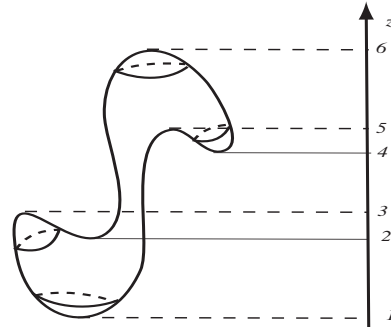

**Fig. 6.3.** An embedding of  $S^2$  in  $\mathbb{R}^3$ .

**Exercise 6.23.** Consider the  $S$ -shaped embedding in  $\mathbb{R}^3$  of the two sphere depicted in Figure 6.3. The height function  $h(x, y, z) = z$  induces a Morse function on  $S^2$  with six critical points. This height function has all the required properties.  $\square$

**Exercise 6.24.** We have

$$\nabla f = (1 - z^2) \frac{\partial}{\partial z},$$

and therefore the gradient flow equation (6.1) has the form

$$\dot{z} = (z^2 - 1), \quad \dot{\theta} = 0, \quad z(0) = z_0, \quad \theta(0) = \theta_0, \quad z \in [-1, 1].$$

This equation is separable and we deduce

$$\frac{dz}{z^2 - 1} = dt \iff \left( \frac{1}{z+1} + \frac{1}{1-z} \right) dz = -2dt.$$

Integrating from 0 to  $t$  we deduce

$$\log\left(\frac{1+z}{1-z}\right) = \log\left(e^{-2t} \frac{1+z_0}{1-z_0}\right) \implies \frac{1+z}{1-z} = e^{-2t} \frac{1+z_0}{1-z_0}.$$

We conclude that

$$z = \phi_t(z_0) := \frac{C(z_0) - e^{2t}}{C(z_0) + e^{2t}}, \quad C(z) := \frac{1+z}{1-z}.$$

Hence

$$\Phi_t(z, \theta) = (\phi_t(z), \theta).$$

Now

$$\omega_g = d\theta \wedge dz \implies \lambda_t(z) = \frac{d}{dz} \phi_t(z).$$

Using the equalities

$$\phi_t(z) = 1 - \frac{2e^{2t}}{C(z) + e^{2t}}, \quad C(z) = \frac{2}{1-z} - 1$$

we deduce

$$\lambda_t = \frac{2e^{2t}}{(z-1)^2(C(z) + e^{2t})^2},$$

which shows that as  $t \rightarrow \infty$   $\lambda_t$  converges to 0 uniformly on the compacts of  $S^2 \setminus \{N\} = S^2 \setminus \{z = 1\}$ .

Let  $u \in C^\infty(S^2)$  and set  $u_0 = u(N)$ . Then

$$\left( \int_{S^2} u \omega_t \right) - u_0 = \int_{S^2} (u - u_0) \omega_t$$

Set  $v = u - u_0$ . Fix a tiny disk  $D_\varepsilon$  of radius  $\varepsilon > 0$  centered at the north pole.

We then have

$$\left| \int_{S^2} v \omega_t \right| \leq \underbrace{\left| \int_{D_\varepsilon} v \lambda_t \omega_g \right|}_{A(t, \varepsilon)} + \underbrace{\left| \int_{S^2 \setminus D_\varepsilon} v \lambda_t \omega_g \right|}_{B(t, \varepsilon)}.$$

Then

$$A(t, \varepsilon) \leq \left( \sup_{D_\varepsilon} |v| \right) \cdot \int_{D_\varepsilon} \omega_t \leq \left( \sup_{D_\varepsilon} |v| \right),$$

while

$$B(t, \varepsilon) \leq \text{area}(S^2) \cdot \sup_{S^2} |v| \cdot \sup_{S^2 \setminus D_\varepsilon} |\lambda_t| \xrightarrow{t \rightarrow \infty} 0.$$

This proves

$$0 \leq \liminf_{t \rightarrow \infty} \left| \int_{S^2} v \omega_t \right| \leq \limsup_{t \rightarrow \infty} \left| \int_{S^2} v \omega_t \right| \leq \left( \sup_{D_\varepsilon} |v| \right), \quad \forall \varepsilon > 0.$$

Since  $v$  is continuous at the north pole and at that point  $v = 0$ , we deduce

$$\lim_{\varepsilon \searrow 0} \left( \sup_{D_\varepsilon} |v| \right) = 0.$$

Hence

$$\lim_{t \rightarrow \infty} \int_{S^2} v \omega_t = 0.$$

□

**Exercise 6.25.** Consider the  $m$ -dimensional torus  $T^m$  with angular coordinates  $(\varphi^1, \dots, \varphi^m)$ . Denote by  $\Delta_m$  the “diagonal” simple closed curve given by the parametrization  $\varphi^i(t) = t, t \in [0, 2\pi], i = 1, \dots, m$ . Denote by  $[\Delta_m]$  the 1-dimensional homology class determined by this oriented. For  $i = 1, \dots, m$  we define  $E_i$  to be the simple closed curve given by the parametrization

$$\varphi^j = \delta_i^j t, \quad \mathcal{T} \in [0, 2\pi], 1 \leq j \leq m.$$

We want to prove that

$$[\Delta_m] = \sum_{i=1}^m [E_i].$$

The depicted in Figure 6.4 in the case  $m = 3$

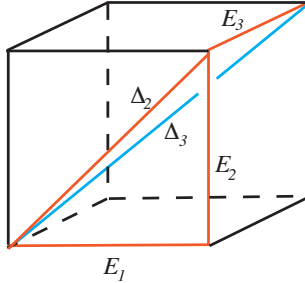

**Fig. 6.4.** A fundamental domain for the lattice  $(2\pi\mathbb{Z})^3$ .

The cube denotes the fundamental domain of the lattice  $(2\pi\mathbb{Z})^3$ . The torus is obtained by identifying the faces of this cube using the gluing rules

$$x^i = x^i + 2\pi, \quad i = 1, 2, 3.$$

We have the equalities of simplicial chains

$$\Delta_3 - \Delta_2 - E_3 = \text{boundary of triangle}, \quad \Delta_2 - E_1 - E_2 = \text{boundary of triangle}.$$

These lead to identities in homology

$$[\Delta_3] = [\Delta_2] + [E_3], \quad [\Delta_2] = [E_1] + [E_2].$$

The argument for general  $m$  should now be obvious. □

**Exercise 6.26** Let  $n := \dim V$ . Then

$$\dim \text{End}_-(V) = \binom{n}{2}, \quad \dim \text{End}_+(V) = \binom{n+1}{2}$$

and thus

$$\dim \text{End}_-(V) + \dim \text{End}_+(V) = n^2 = \dim \text{End}(V).$$

If  $S \in \text{End}_-(V)$  and  $T \in \text{End}_+(V)$ , then

$$\langle S, T \rangle = \text{tr } ST^* = \text{tr } ST = -\text{tr } S^*T = -\text{tr } TS^* = -\langle T, S \rangle$$

so that

$$\langle S, T \rangle = 0.$$

This completes part (a).

(b) Observe that  $T_1 SO(V) = \text{End}_-(V)$ . Fix an orthonormal basis

$$\{ e_i; \quad i = 1, 2, \dots, n \}$$

of  $V$  consisting of eigenvectors of  $A$ ,

$$Ae_i = \lambda_i e_i.$$

We assume  $\lambda_i < \lambda_j$  if  $i < j$ .

If  $T \in SO(V)$  is a critical point of  $f_A$ , then for every  $X \in \text{End}_-(V)$  we have

$$\left. \frac{d}{dt} \right|_{t=0} f_A(Te^{tX}) = 0 \iff \text{tr } ATX = 0, \quad \forall X \in \text{End}_-(V).$$

From part (a) we deduce that  $T$  is a critical point of  $f_A$  if and only if  $AT$  is a symmetric operator, i.e.,

$$AT = T^*A = T^{-1}A \iff TAT = A.$$

If  $T$  is described in the basis  $(e_i)$  by the matrix  $(t_j^i)$ ,

$$Te_j = \sum_i t_j^i e_i, \quad \forall j,$$

then the symmetry of  $AT$  translates into the collection of equalities

$$\lambda_i t_j^i = \lambda_j t_i^j, \quad \forall i, j.$$

We want to prove that these equalities imply that  $t_j^i = 0, \forall i \neq j$ , i.e.,  $T$  is diagonal.

Indeed, since  $T$  is orthogonal we deduce that the sum of the squares of elements in any row, or in any column is 1. Hence

$$1 = \sum_j (t_j^i)^2 = \sum_j \left( \frac{\lambda_j}{\lambda_i} \right)^2 (t_j^j)^2, \quad \forall i.$$

We let  $i = 1$  in the above equality, and we conclude that

$$1 = \sum_{j=1}^n (t_1^j)^2 = \sum_{j=1}^n \left( \frac{\lambda_j}{\lambda_1} \right)^2 (t_1^j)^2$$

( $\lambda_j > \lambda_1, \forall j \neq 1$ )

$$\geq \sum_{j=1}^n (t_1^j)^2 = 1.$$

The equality can hold if and only if  $t_1^j = t_j^1 = 0, \forall j \neq 1$ . We have thus shown that the off-diagonal elements in the first row and the first column of  $T$  are zero. We now proceed inductively.

We assume that the off-diagonal elements in the first  $k$  columns and rows of  $T$  are zero, and we will prove that this is also the case for the  $(k+1)$ -th row and column. We have

$$\begin{aligned} 1 &= \sum_{j=1}^n (t_{k+1}^j)^2 = \sum_{j=1}^n \left( \frac{\lambda_j}{\lambda_{k+1}} \right)^2 (t_{k+1}^j)^2 \\ &= \sum_{j>k} \left( \frac{\lambda_j}{\lambda_{k+1}} \right)^2 (t_{k+1}^j)^2 \geq \sum_{j>k} (t_{k+1}^j)^2 = \sum_{j=1}^n (t_{k+1}^j)^2 = 1. \end{aligned}$$

Since  $\lambda_j > \lambda_{k+1}$  if  $j > k+1$ , we deduce from the above string of (in)equalities that

$$t_{k+1}^j = t_j^{k+1} = 0, \quad \forall j \neq k+1.$$

This shows that the critical points of  $f_A$  are the diagonal matrices

$$\text{Diag}(\epsilon_1, \dots, \epsilon_n), \quad \epsilon_j = \pm 1, \quad \prod_{j=1}^n \epsilon_j = 1.$$

Their number is

$$\binom{n}{0} + \binom{n}{2} + \binom{n}{4} + \dots = 2^{n-1}.$$

Fix a vector  $\epsilon \in \{-1, 1\}^n$  with the above properties and denote by  $T_\epsilon$  the corresponding critical point of  $f_A$ . We want to show that  $T_\epsilon$  is a nondegenerate critical point and then determine its Morse index,  $\lambda(\epsilon)$ .

A neighborhood of  $T_\epsilon$  in  $SO(V)$  can be identified with a neighborhood of  $0 \in \text{End}_-(V)$  via the exponential map

$$\text{End}_-(V) \ni X \mapsto T_\epsilon \exp(X) \in SO(V).$$

Using the basis  $(e_i)$  we can identify  $X \in SO(V)$  with its matrix  $(x_j^i)$ . Since  $x_j^i = -x_i^j$  we can use the collection

$$\{x_j^i; 1 \leq j < i \leq n\}$$

as local coordinates near  $T_\epsilon$ . We have

$$\exp(X) = \mathbb{1}_V + X + \frac{1}{2}X^2 + O(3),$$

where  $O(r)$  denotes terms of size less than some constant multiple of  $\|X\|^r$  as  $\|X\| \rightarrow 0$ . Then

$$f_A(T_\epsilon \exp(X)) = f_A(T_\epsilon) - \frac{1}{2} \text{tr}(AT_\epsilon X^2) + O(3).$$

Thus the Hessian of  $f_A$  at  $T_\epsilon$  is given by the quadratic form

$$\mathcal{H}_\epsilon(X) = -\frac{1}{2} \text{tr}(AT_\epsilon X^2) = -\frac{1}{2} \sum_{j=1}^n \epsilon_j \lambda_j \sum_{k=1}^n x_k^j x_j^k$$

$$(x_k^j = -x_j^k)$$

$$= \frac{1}{2} \sum_{j,k=1}^n \epsilon_j \lambda_j (x_k^j)^2 = \frac{1}{2} \sum_{1 \leq j < k \leq n} (\epsilon_j \lambda_j + \epsilon_k \lambda_k) (x_k^j)^2.$$

The last equalities show that  $\mathcal{H}_\epsilon$  diagonalizes in the coordinates  $(x_k^j)$  and its eigenvalues are

$$\mu_{jk} = \mu_{jk}(\epsilon) := (\epsilon_j \lambda_j + \epsilon_k \lambda_k), \quad 1 \leq k < j \leq n.$$

None of these eigenvalues is zero, since  $0 < \lambda_k < \lambda_j$  if  $k < j$ . Moreover,

$$\mu_{jk}(\epsilon) < 0 \iff \underbrace{\epsilon_j, \epsilon_k < 0}_{\text{Type 1}} \quad \text{or} \quad \underbrace{\epsilon_j < 0 < \epsilon_k}_{\text{Type 2}}.$$

For  $i = 1, 2$  we denote by  $\lambda_i(\epsilon)$  the number of Type  $i$  negative eigenvalues  $\mu_{jk}(\epsilon)$  so that

$$\lambda(\epsilon) = \lambda_1(\epsilon) + \lambda_2(\epsilon).$$

We set

$$Z_\epsilon := \{j; \epsilon_j < 0\}, \quad \nu(\epsilon) := \#Z_\epsilon.$$

Observe that  $\nu(\epsilon)$  is an even, nonnegative integer. The number of Type 1 negative eigenvalues is then

$$\lambda_1(\epsilon) = \sum_{j \in Z_\epsilon} \#\{k \in Z_\epsilon; k < j\} = \binom{\nu(\epsilon)}{2}.$$

On the other hand, we have

$$\lambda_2(\epsilon) = \sum_{j \in Z_\epsilon} \#\{k \notin Z_\epsilon; k < j\}.$$

Hence

$$\lambda(\epsilon) = \lambda_1(\epsilon) + \lambda_2(\epsilon) = \sum_{j \in Z_\epsilon} \#\{k < j\} = \sum_{j \in Z_\epsilon} (j-1) = \sum_{j \in Z_\epsilon} j - \nu(\epsilon).$$

(c) To find a compact description for the Morse polynomial of  $f_A$  we need to use a different kind of encoding. For every positive integer  $k$  we denote by  $I_{k,n}$  the collection of strictly increasing maps

$$\{1, 2, \dots, k\} \rightarrow \{1, 2, \dots, n\}.$$

For  $\varphi \in I_{k,n}$  we set

$$|\varphi| := \sum_{j=1}^k \varphi(j).$$

Define for uniformity

$$I_{0,n} := \{*\}, \quad |*| := 0.$$

Denote by  $P_n$  the Morse polynomial of  $f_A : SO(V) \rightarrow \mathbb{R}$ ,  $n = \dim V$ . Then

$$P_n(t) = \sum_{k \text{ even}} t^{-k} \sum_{\varphi \in I_{k,n}} t^{|\varphi|}.$$

For every  $k$ , even or not, define

$$S_{k,n}(t) = \sum_{\varphi \in I_{k,n}} t^{|\varphi|},$$

and consider the Laurent polynomial in two variables

$$Q_n(t, z) = \sum_k z^{-k} S_{k,n}(t).$$

If we set

$$Q_n^\pm(t, z) = \frac{1}{2} (Q_n(t, z) \pm Q_n(t, -z)),$$

then



$$P_n(t) = Q_n^+(t, z = t).$$

For every  $k$ , even or not, an increasing map  $\varphi \in I_{k,n}$  can be of two types.

- A.  $\varphi(k) < n \iff \varphi \in I_{k,n-1}$ .
- B.  $\varphi(k) = n$ , so that  $\varphi$  is completely determined by its restriction

$$\varphi|_{\{1, \dots, k-1\}}$$

which defines an element  $\varphi' \in I_{k-1, n-1}$  satisfying

$$|\varphi'| = |\varphi| - n.$$

The sum  $S_{k,n}(t)$  decomposes according to the two types

$$S_{k,n} = A_{k,n}(t) + B_{k,n}(t).$$

We have

$$A_{k,n}(t) = S_{k,n-1}(t), \quad B_{k,n}(t) = t^n S_{k-1, n-1}(t).$$

We multiply the above equalities by  $z^{-k}$  and we deduce

$$z^{-k} S_{k,n}(t) = z^{-k} S_{k,n-1} + z^{-k} t^n S_{k-1, n-1}.$$

If we sum over  $k$  we deduce

$$Q_n(t, z) = Q_{n-1}(t, z) + z^{-1} t^n Q_{n-1}(t, z) = (1 + z^{-1} t^n) Q_{n-1}(t, z).$$

We deduce that for every  $n > 2$  we have

$$Q_n(t, z) = \left( \prod_{m=3}^n (1 + z^{-1} t^m) \right) Q_2(t, z).$$

On the other hand, we have

$$\begin{aligned} Q_2(t, z) &= S_{0,2}(t) + z^{-1} S_{1,2}(t) + z^{-2} S_{2,2}(t) = 1 + z^{-1}(t + t^2) + z^{-2} t^3 \\ &= (1 + z^{-1} t)(1 + z^{-1} t^2), \\ Q_2^+(t, z) &= 1 + z^{-2} t^3, \quad Q_2^+(t, z = t) = 1 + t. \end{aligned}$$

We deduce that

$$Q_n(t, z) = \prod_{m=1}^n (1 + z^{-1} t^m), \quad Q_n^+(t, z) = \frac{1}{2} \prod_{m=1}^n (1 + z^{-1} t^m) + \frac{1}{2} \prod_{m=1}^n (1 - z^{-1} t^m),$$

so that

$$P_n(t) = Q_n^+(t, z)|_{z=t} = \frac{1}{2} \prod_{m=1}^n (1 + t^{m-1}) + \underbrace{\frac{1}{2} \prod_{m=1}^n (1 - t^{m-1})}_{=0} = \prod_{k=1}^{n-1} (1 + t^k). \quad \square$$

**Exercise 6.28** For a proof and much more we refer to [DV]. □

**Exercise 6.29** Part (a) is immediate. Let  $v = P_L v + P_{L^\perp} v = v_L + v_{L^\perp} \in V$  (see Figure 6.5). Then

$$P_{\Gamma_S} v = x + Sx, \quad x \in L \iff v - (x + Sx) \in \Gamma_S^\perp$$

$$\iff \exists x \in L, \quad y \in L^\perp \quad \text{such that} \quad \begin{cases} x + S^*y = v_L, \\ Sx - y = v_{L^\perp}. \end{cases}$$

Consider the operator  $\mathfrak{S} : L \oplus L^\perp \rightarrow L \oplus L^\perp$ , which has the block decomposition

$$\mathfrak{S} = \begin{bmatrix} \mathbb{1}_L & S^* \\ S & -\mathbb{1}_{L^\perp} \end{bmatrix}.$$

Then the above linear system can be rewritten as

$$\mathfrak{S} \cdot \begin{bmatrix} x \\ y \end{bmatrix} = \begin{bmatrix} v_L \\ v_{L^\perp} \end{bmatrix}.$$

Now observe that

$$\mathfrak{S}^2 = \begin{bmatrix} \mathbb{1}_L + S^*S & 0 \\ 0 & \mathbb{1}_{L^\perp} + SS^* \end{bmatrix}.$$

Hence  $\mathfrak{S}$  is invertible and

$$\begin{aligned} \mathfrak{S}^{-1} &= \begin{bmatrix} (\mathbb{1}_L + S^*S)^{-1} & 0 \\ 0 & (\mathbb{1}_{L^\perp} + SS^*)^{-1} \end{bmatrix} \cdot \mathfrak{S} \\ &= \begin{bmatrix} (\mathbb{1}_L + S^*S)^{-1} & (\mathbb{1}_L + S^*S)^{-1}S^* \\ (\mathbb{1}_{L^\perp} + SS^*)^{-1}S & -(\mathbb{1}_{L^\perp} + SS^*)^{-1} \end{bmatrix}. \end{aligned}$$

We deduce

$$x = (\mathbb{1}_L + S^*S)^{-1}v_L + (\mathbb{1}_L + S^*S)^{-1}S^*v_{L^\perp}$$

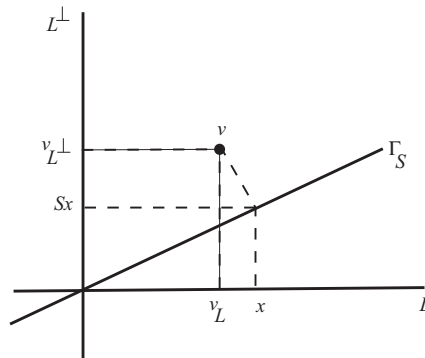

**Fig. 6.5.** Subspaces as graphs of linear operators.

and

$$P_{\Gamma_S} v = \begin{bmatrix} x \\ Sx \end{bmatrix}.$$

Hence  $P_{\Gamma_S}$  has the block decomposition

$$\begin{aligned} P_{\Gamma_S} &= \begin{bmatrix} \mathbb{1}_L \\ S \end{bmatrix} \cdot [(\mathbb{1}_L + S^*S)^{-1} \quad (\mathbb{1}_L + S^*S)^{-1}S^*] \\ &= \begin{bmatrix} (\mathbb{1}_L + S^*S)^{-1} & (\mathbb{1}_L + S^*S)^{-1}S^* \\ S(\mathbb{1}_L + S^*S)^{-1} & S(\mathbb{1}_L + S^*S)^{-1}S^* \end{bmatrix}. \end{aligned}$$

If we write  $P_t := P_{\Gamma_{tS}}$ , we deduce

$$P_t = \begin{bmatrix} (\mathbb{1}_L + t^2S^*S)^{-1} & t(\mathbb{1}_L + t^2S^*S)^{-1}S^* \\ tS(\mathbb{1}_L + t^2S^*S)^{-1} & t^2S(\mathbb{1}_L + t^2S^*S)^{-1}S^* \end{bmatrix}.$$

Hence

$$\frac{d}{dt}P_t|_{t=0} = \begin{bmatrix} 0 & S^* \\ S & 0 \end{bmatrix} = S^*P_{L^\perp} + SP_L. \quad \square$$

**Exercise 6.30.** Suppose  $L \in G_k(V)$ . With respect to the decomposition  $V = L \oplus L^\perp$  the operator  $A$  has the block decomposition

$$A = \begin{bmatrix} A_L & B^* \\ B & A_{L^\perp} \end{bmatrix},$$

$$B \in \text{Hom}(L, L^\perp), A_L \in \text{Hom}(L, L), A_{L^\perp} \in \text{Hom}(L^\perp, L^\perp).$$

Suppose we are given  $S \in \text{Hom}(L, L^\perp) \cong T_L G_k(V)$ . Then

$$\begin{aligned} \frac{d}{dt}\Big|_{t=0} h_A(\Gamma_{tS}) &= -\frac{d}{dt}\Big|_{t=0} \mathbf{Re} \text{tr}(AP_{\Gamma_{tS}}) = -\mathbf{Re} \text{tr}\left(A \frac{d}{dt}\Big|_{t=0} P_{\Gamma_{tS}}\right) \\ &= -\mathbf{Re} \text{tr}(B^*S + BS^*) = -2\mathbf{Re} \text{tr}(BS^*). \end{aligned}$$

We see that  $L$  is a critical point of  $h_A$  if and only if

$$\mathbf{Re} \text{tr}(BS^*) = 0, \quad \forall S \in \text{Hom}(L, L^\perp) \iff B = 0.$$

Hence  $L$  is a critical point of  $h_A$  if and only if  $A$  has a diagonal block decomposition with respect to  $L$ ,

$$A = \begin{bmatrix} A_L & 0 \\ 0 & A_{L^\perp} \end{bmatrix}.$$

This happens if and only if  $AL \subset L$ . This proves part (a).

Choose a unitary frame  $(e_i)_{1 \leq i \leq n}$  of  $V$  consisting of eigenvectors of  $A$ ,

$$Ae_i = a_i e_i, \quad a_i \in \mathbb{R}, \quad i < j \implies a_i < a_j.$$

Then  $L \subset V$  is an invariant subspace of  $V$  if and only if there exists a cardinality  $k$  subset  $I = I_L \subset \{1, \dots, n\}$  such that

$$L = V_I = \text{span}_{\mathbb{C}}\{e_i; i \in I_L\}.$$

Denote by  $J = J_L$  the complement of  $I$  and by  $V_J$  the subspace spanned by  $\{e_j; j \in J\}$ . Any  $S \in \text{Hom}(V_I, V_J)$  is described by a matrix

$$S = (s_{ij})_{i \in I, j \in J}.$$

Then

$$\begin{aligned} h_A(\Gamma_S) &= -\mathbf{Re} \text{tr} \begin{bmatrix} A_L(\mathbb{1}_L + S^*S)^{-1} & A_L(\mathbb{1}_L + S^*S)^{-1}S^* \\ A_{L^\perp}S(\mathbb{1}_L + S^*S)^{-1} & A_{L^\perp}S(\mathbb{1}_L + S^*S)^{-1}S^* \end{bmatrix} \\ &= -\mathbf{Re} \text{tr} A_L(\mathbb{1}_L + S^*S)^{-1} - \mathbf{Re} \text{tr} A_{L^\perp}S(\mathbb{1}_L + S^*S)^{-1}S^*. \end{aligned}$$

If we denote by  $Q_L$  the Hessian of  $h_A$  at  $L$  then from the Taylor expansions ( $\|S\| \ll 1$ )

$$\begin{aligned} A_L(\mathbb{1}_L + S^*S)^{-1} &= A_L - A_L S^*S + \text{higher order terms}, \\ A_{L^\perp}S(\mathbb{1}_L + S^*S)^{-1}S^* &= A_{L^\perp}S S^* + \text{higher order terms}, \end{aligned}$$

we deduce

$$Q_L(S, S) = \mathbf{Re} \text{tr} A_L S^*S - \mathbf{Re} \text{tr} A_{L^\perp}S S^*, \quad \forall S \in \text{Hom}(L, L^\perp) = T_L G_k(V).$$

Using the matrix description  $S = (s_{ij})$  of  $S$  we deduce

$$Q_L(S, S) = \sum_{i \in I} \lambda_i \sum_{j \in J} |s_{ij}|^2 - \sum_{j \in J} \lambda_j \sum_{i \in I} |s_{ij}|^2 = \sum_{(i,j) \in I \times J} (\lambda_i - \lambda_j) |s_{ij}|^2.$$

This shows that the Hessian of  $h_A$  at  $L$  is nondegenerate and we denote by  $\lambda(A, L)$  its index. It is an even integer because the coordinates  $s_{ij}$  are complex. Moreover,

$$\lambda(A, L) = 2\mu(I_L) = 2\#\{(i, j) \in I_L \times J_L; i < j\}.$$

Setting

$$I = I_L = \{i_1, \dots, i_k\}, \quad J = J_L$$

we deduce

$$\begin{aligned} \mu(I) &= \sum_{j \in J} \#\{i \in I; i < j\} \\ &= 0 \cdot (i_1 - 1) + \dots + (k-1) \cdot (i_k - i_{k-1} - 1) + k(n - i_k) \\ &= 1 \cdot (i_2 - i_1) + \dots + (k-1)(i_k - i_{k-1}) + k(n - i_k) - \sum_{i=1}^{k-1} i \\ &= -\sum_{i \in I} i + nk - \frac{k(k-1)}{2} = \sum_{i \in I} (n - i) - \frac{k(k-1)}{2} \\ &= \sum_{\ell=1}^k (n - i_\ell - (k - \ell)). \end{aligned}$$

Define

$$m_\ell := n - i_\ell - (k - \ell) = (n - k) - (i_\ell - \ell)$$

so that

$$\mu_I = \sum_{\ell=1}^k m_\ell. \tag{6.7}$$

Since

$$0 \leq (i_1 - 1) \leq (i_2 - 2) \leq \dots \leq (i_k - k) \leq (n - k)$$

we deduce

$$n - k \geq m_1 \geq \dots \geq m_k \geq 0.$$

Given a collection  $(m_1, \dots, m_k)$  with the above properties we can recover  $I$  by setting

$$i_\ell = (n - k) + \ell - m_\ell.$$

The Morse numbers of  $h_A$  are

$$M_{k,n}(\lambda) = \#\{L; \lambda(A, L) = \lambda\} = \#\{I; 2\#\mu(I) = \lambda\}.$$

The Morse polynomial is

$$M_{k,n}(t) = \sum_{\lambda} M_{k,n}(\lambda)t^\lambda = \sum_{\lambda} M_{k,n}(2\lambda)t^{2\lambda}.$$

For every nonnegative integers  $(a, b, c)$  we denote by  $P(a|b, c)$  the number of partitions of  $a$  as a sum of  $b$  nonnegative integers  $\leq c$ ,

$$a = x_1 + \dots + x_b, \quad 0 \leq x_1 \leq \dots \leq x_b \leq c.$$

Let  $P_{b,c}(t)$  denote the generating polynomial

$$P_{b,c}(t) := \sum_a P(a|b, c)t^a.$$

The equality (6.7) implies

$$M_{k,n}(2\lambda) = P_{k,n-k}(\lambda) \implies M_{k,n}(t) = P_{k,n-k}(t^2).$$

The polynomial  $P_{k,n-k}(t)$  can be expressed as a rational function

$$P_{k,n-k}(t) = \frac{\prod_{a=1}^n (1 - t^a)}{\prod_{b=1}^k (1 - t^b) \cdot \prod_{c=1}^{n-k} (1 - t^c)}.$$

For a proof we refer to [Nil, Lemma 7.4.27]. □

**Exercise 6.32.** For a short proof that (3.5) is the gradient flow of the function  $f_A$  in (3.4) we refer to [DV, §2]. To find the critical points of  $f_A$  and the conclude that it is Morse-Bott we proceed as follows.

Consider an orthonormal basis of eigenvectors of  $A$ ,  $e_1, \dots, e_n$ ,  $n = \dim E$  such that

$$Ae_i = \lambda_i e_i, \quad \lambda_1 \geq \lambda_2 \geq \dots \geq \lambda_n.$$

For every subset  $I \subset \{1, \dots, n\}$  we write

$$E_I := \text{span}\{e_i, i \in I\}, \quad I^\perp := \{1, \dots, n\} \setminus I.$$

For  $\#I = k$  we set

$$\text{Gr}_k(E)_I = \{L \in \text{Gr}_k; L \cap E_I^\perp = 0\}.$$

$\text{Gr}_k(E)_I$  is a semialgebraic open subset of  $\text{Gr}_k(E)$  and

$$\text{Gr}_k(E) = \bigcup_{\#I=k} \text{Gr}_k(E)_I.$$

A subspace  $L \in \text{Gr}_k(E)_I$  can be represented as the graph of a linear map  $S = S_L : E_I \rightarrow E_I^\perp$ , i.e.,

$$L = \{x + Sx; x \in E_I\}.$$

Using the basis  $(e_i)_{i \in I}$  and  $(e_\alpha)_{\alpha \in I^\perp}$  we can represent  $S$  as a  $(n - k) \times k$  matrix

$$S = [s_{\alpha i}]_{i \in I, \alpha \in I^\perp}.$$

The subspaces  $E_I$  and  $E_I^\perp$  are  $A$  invariant. Then  $e^{At}L \in \text{Gr}_k(E)_I$ , and it is represented as the graph of the operator  $S_t = e^{At}S e^{-At}$  described by the matrix

$$\text{Diag}(e^{\lambda_\alpha t}, \alpha \in I^\perp) \cdot S \cdot \text{Diag}(e^{-\lambda_i t}, i \in I) = [e^{(\lambda_\alpha - \lambda_i)t} s_{\alpha i}]_{i \in I, \alpha \in I^\perp}.$$

□

**Exercise 6.36** See [Mat, Lemma 7.3].

□

**Exercise 6.40.** (a) Fix an almost complex structure on  $V$  tamed by  $\omega$  and denote by  $g(\bullet, \bullet)$  the associated metric

$$g(u, v) = \omega(u, Jv) \iff \omega(u, v) = g(Ju, v), \quad \forall u, v \in V.$$

Identify  $V$  and its dual using the metric  $g$ . Then for every subspace  $L \subset V$ ,  $L^\perp \subset V^*$  is identified with the orthogonal complement of  $L$ . Moreover,

$$I_\omega = -J.$$

Then

$$L^\omega \cong \{v \in V; g(Jv, x) = 0, \forall x \in L\} = JL^\perp.$$

(b)  $L$  is isotropic if and only if  $L \subset JL^\perp$ , and thus

$$\dim L + \dim L^\omega = \dim V, \quad \dim L \subset \dim L^\omega.$$

Thus  $\dim L \leq \frac{1}{2} \dim V$  with equality iff  $\dim L = \dim L^\omega$ , iff  $L = L^\omega$ .

(c) Since  $L_0$  and  $L_1$  are transversal, we have natural isomorphisms

$$L_0 \oplus L_1 \rightarrow L_0 + L_1 \rightarrow V.$$

A subspace  $L \subset V$  of dimension  $\dim L = \dim L_0 = \dim L_1$  is transversal to  $L_1$  if and only if it is the graph of a linear operator

$$A : L_0 \rightarrow L_1.$$

Let  $u_0, v_0 \in L_0$ . Then  $Au_0, Av_0 \in L_1$  and  $u_0 + Av_0, v_0 + Au_0 \in L$ , so that

$$\begin{aligned} 0 &= \omega(u_0 + Au_0, v_0 + Av_0) \\ &= \omega(u_0, v_0) + \omega(Au_0, Av_0) + \omega(Au_0, v_0) + \omega(u_0, Av_0) \\ &= -\omega(v_0, Au_0) + \omega(u_0, Av_0) = Q(u_0, v_0) - Q(v_0, u_0). \end{aligned}$$

Let  $u_0 \in L_0$ . Then

$$\begin{aligned} Q(u_0, u) = 0, \quad \forall u \in L_0 &\iff \omega(u_1, u) = 0, \quad \forall u \in L_0, \quad (u_1 = Au_0) \\ &\iff \omega(u_1, v) = 0, \quad \forall v \in V \iff u_1 = 0. \end{aligned}$$

Thus  $Q$  is nondegenerate iff  $\ker A = 0$  iff  $L$  is transversal to  $L_0$  as well.

(b) Since this statement is coordinate independent, it suffices to prove it for a special choice of coordinates. Thus we can assume

$$M = \mathbb{R}^n, \quad E = \mathbb{R}^n \times M = \mathbb{R}^n \times \mathbb{R}^n, \quad x = 0 \in \mathbb{R}^n.$$

The coordinates on  $\mathbb{R}^n \times \mathbb{R}^n$  are  $(\xi_i, x^j)$ . Then

$$L_0 = 0 \times \mathbb{R}_x^n, \quad L_1 = \mathbb{R}_\xi^n \times 0.$$

Then  $L$  is the graph of the linear operator

$$0 \times \mathbb{R}_x^n \rightarrow \mathbb{R}_\xi^n \times 0$$

given by the differential at  $x = 0$  of the map  $\mathbb{R}^n \ni x \mapsto \xi = df(x) \in \mathbb{R}^n$ . This is precisely the Hessian of  $f$  at 0. Thus if the Hessian is given by the symmetric matrix  $(H_{ij})$ , then

$$A\partial_{x^j} = \sum_i H_{ij} \partial_{\xi_i} \quad \text{and} \quad \omega(\partial_{x^i}, A\partial_{x^j}) = H_{ij}.$$

□

**Exercise 6.41.** (a) and (c) We have a tautological diffeomorphism

$$\gamma : M \rightarrow \Gamma_{df}, \quad x \mapsto (df(x), x).$$

Then

$$\gamma^*\theta = df, \quad \gamma^*\omega = -\gamma^*(d\theta) = -d\gamma^*\theta = -d(df) = 0.$$

This also implies part (c), since  $\gamma^*d\theta$  is the differential of  $f$ .

(d) We need a few differential-geometric facts.

**A.** Suppose  $M$  is a smooth manifold and  $\alpha_t, t \in \mathbb{R}$ , is a smooth one parameter family (path) of differential forms of the same degree  $k$ . Denote by  $\dot{\alpha}_t$  the path of differential forms defined by

$$\dot{\alpha}_t(x) = \lim_{h \rightarrow 0} \frac{1}{h} (\alpha_{t+h}(x) - \alpha_t(x)) \in \Lambda^k T_x^* M, \quad \forall x \in M, \quad t \in \mathbb{R}.$$

Construct the cylinder  $\hat{M} = \mathbb{R} \times M$  and denote by  $i_t : M \rightarrow \hat{M}$  the inclusion

$$M \hookrightarrow \mathbb{R} \times M, \quad x \mapsto (t, x).$$

The *suspension* of the family  $\alpha_t$  is the  $k$ -form  $\hat{\alpha}$  on  $\hat{M}$  uniquely determined by the conditions

$$\partial_t \lrcorner \hat{\alpha} = 0, \quad i_t^* \hat{\alpha} = \alpha_t.$$

We then have the equality

$$\dot{\alpha}_t = i_t^* L_{\partial_t} \hat{\alpha}.$$

Indeed, if we denote by  $d$  the exterior derivative on  $M$  and by  $\hat{d}$  the exterior derivative on  $\hat{M}$ , then  $\hat{d} = dt \wedge \partial_t + d$ , and

$$L_{\partial_t} \hat{\alpha} = \hat{d}(\partial_t \lrcorner \hat{\alpha}) + \partial_t \lrcorner (\hat{d}\hat{\alpha}) = \hat{\alpha}.$$

**B.** Suppose  $\Phi : N_0 \rightarrow N_1$  is a *diffeomorphism* between two smooth manifolds,  $\alpha \in \Omega^k(N_1)$ ,  $X \in \text{Vect}(M)$ . Then

$$L_X \Phi^* \alpha = \Phi^* (L_{\Phi_* X} \alpha).$$

Indeed, this a fancy way of rephrasing the coordinate independence of the Lie derivative. Equivalently, if  $\beta \in \Omega^k(M)$  and we define the pushforward

$$\Phi_* \beta := (\Phi^{-1})^* \beta = (\Phi^*)^{-1} \beta,$$

then we have

$$\Phi_* (L_X \beta) = L_{\Phi_* X} \Phi_* \beta.$$

**C.** Suppose  $\Phi_t$  is a one parameter family of diffeomorphisms of  $M$ . This determines a *time* dependent vector field on  $M$

$$X_t(x) = \left. \frac{d}{dh} \right|_{h=0} \Phi_{t+h}(x), \quad \forall t \in \mathbb{R}, \quad x \in M.$$



We obtain a diffeomorphism

$$\hat{\Phi} : \hat{M} \rightarrow \hat{M}, \quad (t, x) \mapsto (t, \Phi_t(x)).$$

Observe that

$$\hat{\Phi}_*(\partial_t) = \hat{X} = \partial_t + X_t \in \text{Vect}(\hat{M}).$$

Suppose  $\alpha$  is a  $k$ -form on  $M$ . We denote by  $\alpha_t$  the path of forms  $\alpha_t := \Phi_t^*(M)$ . If we denote by  $\pi : \hat{M} \rightarrow M$  the natural projection, then we have the equality

$$\hat{\alpha} = \hat{\Phi}^* \pi^* \alpha.$$

From **A** we deduce

$$\dot{\alpha}_t := i_t^* L_{\partial_t} \hat{\alpha}.$$

From **B** we deduce

$$\hat{\Phi}_*(L_{\partial_t} \hat{\alpha}) = L_{\Phi_* \partial_t} (\hat{\Phi}_* \hat{\alpha}) = L_{\hat{X}} \pi^* \alpha,$$

so that

$$L_{\partial_t} \hat{\alpha} = \hat{\Phi}^*(L_{\hat{X}} \pi^* \alpha) \implies \dot{\alpha}_t = \Phi_t^*(L_{\hat{X}} \pi^* \alpha).$$

Now observe that

$$L_{\hat{X}} \pi^* \alpha = L_{\partial_t} \pi^* \alpha + L_{X_t} \pi^* \alpha = L_{X_t} \pi^* \alpha.$$

Hence

$$\dot{\alpha}_t = \Phi_t^* L_{X_t} \alpha.$$

Suppose  $X_t \lrcorner d\alpha = d\gamma_t, \forall t$ . Then

$$L_{X_t} \alpha = X_t \lrcorner d\alpha + dX_t \lrcorner \alpha = d(\underbrace{\gamma_t + X_t \lrcorner \alpha}_{\varphi_t}),$$

so that

$$\dot{\alpha}_t = d \underbrace{\Phi_t^*(\underbrace{\gamma_t + X_t \lrcorner \alpha}_{\varphi_t})}_{\varphi_t} \implies \alpha_t - \alpha_0 = d \int_0^t \varphi_s ds.$$

This shows that if  $X_t \lrcorner d\alpha$  is exact on  $M$  for every  $t$ , then for every submanifold  $L \subset M$  the restriction  $\alpha_t|_L$  is exact for every  $t > 0$ , provided  $\alpha_0|_L$  is exact.  $\square$

**Exercise 6.45.** (a) The Fubini–Study form is clearly closed and invariant with respect to the tautological action of  $U(n+1)$  on  $\mathbb{C}\mathbb{P}^n$ . Since the action of  $U(n+1)$  is transitive, it suffices to show that  $\omega$  defines a symplectic pairing on the tangent space of one point in  $\mathbb{C}\mathbb{P}^n$ . By direct computation (see a sample in part (b)) one can show that at the point  $[1, 0, 0, \dots, 0]$  and in the affine coordinates  $w_j = z_j/z_0$ , the Fubini–Study form coincides with

$$i \sum_j dw_j \wedge d\bar{w}_j,$$

which is a multiple of the standard symplectic form  $\Omega$  on  $\mathbb{C}^n$  described in Example 3.25.

(b) Notice that if an  $S^1$ -action on a smooth manifold  $M$  is Hamiltonian with respect to a symplectic form  $\omega$ , then it is Hamiltonian with respect to  $c\omega$ , for every nonzero real number  $c$ .

Since the Fubini–Study form is invariant with respect to the tautological  $U(n+1)$ -action on the connected manifold  $\mathbb{C}\mathbb{P}^n$ , and this action is transitive, we deduce that up to a multiplicative constant there exists exactly one  $U(n+1)$ -invariant symplectic form on  $\mathbb{C}\mathbb{P}^n$ .

The computations in Example 3.50 show that the given  $S^1$ -action is Hamiltonian with respect to some  $U(n+1)$ -invariant symplectic form and thus with respect to *any*  $U(n+1)$ -invariant form. In particular, this action is Hamiltonian with respect to the Fubini–Study form. Moreover, the computations in the same Example 3.50 show that a moment map must have the form

$$\mu(\mathbf{z}) = c \frac{\sum_j j |z_j|^2}{|\mathbf{z}|^2},$$

where  $c$  is a real nonzero constant. This constant can be determined by verifying at a (non-fixed) point in  $\mathbb{C}\mathbb{P}^n$  the equality  $d\mu = X \lrcorner \omega$ , where  $X$  is the infinitesimal generator of the  $S^1$ -action.

If we work in the coordinate chart  $z_0 \neq 0$  with  $w_k = z_k/z_0$  then

$$\omega = i\partial\bar{\partial}(1 + |w|^2) = i\partial \frac{\bar{\partial}|w|^2}{1 + |w|^2}.$$

The projective line  $L$  in  $\mathbb{C}\mathbb{P}^n$  described by  $w_2 = \cdots = w_n = 0$  is  $S^1$ -invariant, and along this line we have

$$\begin{aligned} \omega|_L &= i\partial \frac{\bar{\partial}|w_1|^2}{1 + |w_1|^2} = i\partial \left( \frac{1}{1 + |w_1|^2} w_1 d\bar{w}_1 \right) \\ &= i \frac{dw_1 \wedge d\bar{w}_1}{1 + |w_1|^2} - i \frac{|w_1|^2 dw_1 \wedge d\bar{w}_1}{(1 + |w_1|^2)^2} \\ &= \frac{i}{(1 + |w_1|^2)^2} dw_1 \wedge d\bar{w}_1. \end{aligned}$$

If we write  $w_1 = x_1 + iy_1$ , then we deduce that

$$\omega|_L = \frac{2dx_1 \wedge dy_1}{(1 + x_1^2 + y_1^2)^2}.$$

In these coordinates we have

$$\mu|_L(w_1) = c \frac{|w_1|^2}{1 + |w_1|^2}, \quad X = -y_1 \partial_{x_1} + x_1 \partial_{y_1}.$$

Along  $L$  we have

$$X \lrcorner \omega = -2 \frac{x_1 dx_1 + y_1 dy_1}{(1 + x_1^2 + y_1^2)^2} = -\frac{d|w_1|^2}{(1 + |w_1|^2)^2} = d \frac{|w_1|^2}{1 + |w_1|^2} = \frac{1}{c} d\mu|_L.$$

Thus we can take  $c = 1$ . □

*Remark 6.55.* It is interesting to compute the volume of the projective line

$$w_2 = \dots = w_n = 0$$

with respect to the Fubini–Study form. We have

$$\begin{aligned} \text{vol}_\omega(L) &= 2 \int_{\mathbb{R}^2} \frac{dx_1 \wedge dy_1}{(1 + x_1^2 + y_1^2)^2} \\ &\stackrel{(w_1 = re^{i\theta})}{=} \int_0^{2\pi} d\theta \int_0^\infty \frac{2r dr}{(1 + r^2)^2} \\ &\stackrel{(u = 1+r^2)}{=} \int_0^{2\pi} d\theta \int_1^\infty \frac{du}{u^2} = 2\pi. \end{aligned}$$

Thus, if we define the *normalized* Fubini–Study form  $\Phi$  by

$$\Phi = \frac{i}{2\pi} \partial \bar{\partial} \log |\mathbf{z}|^2,$$

we have

$$\int_{\mathbb{C}\mathbb{P}^n} \Phi^n = 1.$$

We deduce that the action of  $\mathbb{T}^n$  given by

$$(e^{2\pi i t_1}, \dots, e^{2\pi i t_n})[z_0, z_1, \dots, z_n] = [z_0, e^{2\pi i t_1} z_1, \dots, e^{2\pi i t_n} z_n]$$

is Hamiltonian with respect to  $\Phi$  with moment map

$$\mu(\mathbf{z}) = \frac{1}{|\mathbf{z}|^2} (|z_1|^2, \dots, |z_n|^2).$$

The image of the moment map is the  $n$ -simplex

$$\Delta = \{\boldsymbol{\rho} \in \mathbb{R}_{\geq 0}^n; \sum_i \rho_i \leq 1\}.$$

Its Euclidean volume is  $\frac{1}{n!}$  and it is equal to the volume of  $\mathbb{C}\mathbb{P}^n$  with respect to the Kähler metric determined by  $\Phi$ ,

$$\text{vol}_\Phi(\mathbb{C}\mathbb{P}^n) = \frac{1}{n!} \int_{\mathbb{C}\mathbb{P}^n} \Phi^n = \frac{1}{n!}. \quad \square$$

**Exercise 6.47** Part (a) is classical; see e.g., [Ni1, Section 3.4.4]. Part(b) is easy.

For part (c), assume  $\mathbb{T} = (\mathbb{R}/\mathbb{Z})^n$ . Thus we can choose global angular coordinates  $(\theta^1, \dots, \theta^n)$  on the Lie algebra  $\mathfrak{t} \cong \mathbb{R}$  such that the characters of  $\mathbb{T}^n$  are described by the functions

$$\chi_{\mathbf{w}}(\theta^1, \dots, \theta^n) = \exp(2\pi i(w_1\theta^1 + \dots + w_n\theta^n)), \quad \mathbf{w} \in \mathbb{Z}^n.$$

We obtain a basis  $\partial_{\theta^j}$  on  $\mathfrak{t}$  and a dual basis  $d\theta^j$  on  $\mathfrak{t}^*$ . We denote by  $(\xi_j)$  the coordinates on  $\mathfrak{t}^*$  defined by the basis  $(d\theta^j)$ . In the coordinates  $(\xi_j)$  the lattice of characters is defined by the conditions

$$\xi_j \in \mathbb{Z}, \quad \forall j = 1, \dots, n.$$

The normalized Lebesgue measure on  $\mathbb{T}^*$  is therefore  $d\xi_1 \cdots d\xi_n$ . Moreover,

$$\int_{\mathbb{R}^n/\mathbb{Z}^n} d\theta^1 \wedge \cdots \wedge d\theta^n = 1.$$

The one-parameter subgroup of  $\mathbb{T}$  generated by  $\partial_{\theta^j}$  defines a flow  $\Phi_t^j$  on  $M$ , and we denote by  $X_j$  its infinitesimal generator. Using the coordinates  $(\xi_j)$  on  $\mathbb{T}^*$  we can identify the moment map with a smooth map

$$\mu : M \rightarrow \mathbb{R}^n, \quad p \mapsto \mu(p) = (\xi_1(p), \dots, \xi_n(p)).$$

Since the action is Hamiltonian, we deduce

$$d\xi_j = X_j \lrcorner \omega, \quad j = 1, \dots, n.$$

Fix a point

$$\xi^0 = (\xi_1^0, \dots, \xi_n^0) \in \text{int } P$$

and a point  $p_0$  in the fiber  $\mu^{-1}(\xi^0) \subset M^*$ .

The vector  $\xi^0$  is a regular value for  $\mu$ , and since  $\mu$  is a proper map we deduce from the Ehresmann fibration theorem that there exists an open contractible neighborhood  $U$  of the point  $\xi^0$  in  $\text{int } P$  and a diffeomorphism

$$\mu^{-1}(U) \longrightarrow \mu^{-1}(\xi^0) \times U.$$

In particular, there exists a smooth map  $\sigma : U \rightarrow M$  which is a section of  $\mu$ , i.e.,  $\mu \circ \sigma = \mathbb{1}_U$ . We now have a diffeomorphism

$$\mathbb{T} \times U \rightarrow \mu^{-1}(U), \quad \mathbb{T} \times U \ni (t, \xi) \mapsto t \cdot \sigma(\xi).$$

Using the diffeomorphism  $\Psi^{-1}$  we pull back the angular forms  $d\theta^j$  on  $\mathbb{T}$  to closed 1-forms  $\varphi^j = (\Psi^{-1})^* d\theta^j$  on  $\mu^{-1}(U)$ . Observe that

$$X_j \lrcorner \varphi^k = \delta_j^k = \text{Kronecker delta}.$$

The collection of 1-forms  $\{\varphi^j, d\xi^k\}$  trivializes  $T^*M$  over  $\mu^{-1}(U)$ , and thus along  $\mu^{-1}(U)$  we have a decomposition of the form

$$\omega = \sum_{j,k} (a_{jk} \varphi^j \wedge \varphi^k + b_j^k \varphi^j \wedge d\xi_k + c^{jk} d\xi_j \wedge d\xi_k).$$

Since

$$X_j \lrcorner \omega = d\xi_j, \quad X_j \lrcorner d\xi_k = \{\xi_j, \xi_k\} = 0$$

we deduce

$$a_{jk} = 0$$

and

$$\omega = \sum_k \varphi^j \wedge d\xi_k + \sum_{j,k} c^{jk} d\xi_j \wedge d\xi^k.$$

Hence

$$\Psi^* \omega = \sum_k \sum_j d\theta^j \wedge d\xi_k + \sum_{j,k} c^{jk} d\xi_j \wedge d\xi^k.$$

Since  $\omega$  is closed, we deduce that the coefficients  $c^{jk}$  must be constant along the orbits, i.e. they are pullbacks via  $\mu$  of functions on  $\mathfrak{t}^*$ . In more concrete terms, the functions  $c^{jk}$  depend only on the variables  $\xi^j$ . We now have a closed 2-form on  $U$ ,

$$\eta = \sum_{j,k} c^{jk} d\xi_j \wedge d\xi_k.$$

Since  $U$  is closed there exists a 1-form  $\lambda = \sum_j \lambda^j d\xi_j$  such that

$$\eta = -d\lambda, \quad \lambda = \sum_k \lambda^k(\xi) d\xi_k \in \Omega^1(U).$$

For every  $\xi \in U$  denote by  $[\lambda(\xi)]$  the image of the vector  $\lambda(\xi) \in \mathbb{R}^n$  in the quotient  $\mathbb{R}^b/\mathbb{Z}^n$ . If we now define a new section

$$s(\xi) = [\lambda(x)] \cdot \sigma(\xi),$$

we obtain a new diffeomorphism

$$\Psi_\lambda : \mathbb{T} \times U, \quad (t, \xi) \mapsto t \cdot s(\xi) = [\lambda(\xi)] \Psi(t, \xi).$$

Observe that

$$\Psi_\lambda^* \omega = \sum_k d(\theta^k + \lambda^k) \wedge d\xi_k - \sum_k d\lambda^k \wedge d\xi_k = \sum_k d\theta^k \wedge d\xi^k.$$

Thus

$$\frac{1}{n!} \Psi_\lambda \omega^n = d\theta^1 \wedge \cdots \wedge d\theta^n \wedge d\xi_1 \wedge \cdots \wedge d\xi_n,$$

so that

$$\int_{\mu^{-1}(U)} \frac{1}{n!} \omega^n = \left( \int_{\mathbb{R}^n/\mathbb{Z}^n} d\theta^1 \wedge \cdots \wedge d\theta^n \right) \left( \int_U d\xi_1 \wedge \cdots \wedge d\xi_n \right) = \text{vol}(U).$$

The result now follows using a partition-of-unity argument applied to an open cover of  $\text{int } P$  with the property that above each open set of this cover,  $\mu$  admits a smooth section.  $\square$

*Remark 6.56.* The above proof reveals much more, namely that in the neighborhood of a generic orbit of the torus action we can find coordinates  $(\xi_j, \theta^k)$  (called “*action-angle coordinates*”) such that all the nearby fibers are described by the equalities  $\xi_j = \text{const}$ , the symplectic form is described by

$$\omega = \sum_k d\theta^k \wedge d\xi^k,$$

and the torus action is described by

$$t \cdot (\xi_j, \theta^k) = (\xi_j, \theta^k + t^k).$$

This fact is known as the *Arnold–Liouville theorem*. For more about this we refer to [Au].  $\square$

**Exercise 6.49** Mimic the proof of Theorem 3.80 and Corollary 3.85.  $\square$

**Exercise 6.50** The group  $\mathbb{Z}/2$  acts by conjugation on

$$X(P)^\mathbb{C} := \{[x, y, z] \in \mathbb{C}\mathbb{P}^2; P(x, y, z) = 0\},$$

and  $X(P)$  is the set of fixed points of this action. Now use Exercise 6.49 and Corollary 5.14.  $\square$

**Exercise 6.51** We have

$$\begin{aligned} J(\mu, \xi, r) &= \int_{\mathbb{R}} e^{(-r+i\mu)x^2+i\xi x} dx = e^{\frac{\xi^2}{4(i\mu-r)}} \int_{\mathbb{R}} e^{(-r+i\mu)\left(x-\frac{i\xi}{2(i\mu-r)}\right)^2} dx \\ &= \frac{e^{\frac{\xi^2}{4(i\mu-r)}}}{(r-i\mu)^{\frac{1}{2}}} \int_{\Gamma} e^{-z^2} dz, \end{aligned}$$

where  $\Gamma$  is the line

$$\Gamma = \left\{ z = (r-i\lambda)^{\frac{1}{2}} \left( x - \frac{i\xi}{2(i\mu-r)} \right); x \in \mathbb{R} \right\}.$$

One can then show that

$$\int_{\Gamma} e^{-z^2} dz = \int_{\mathbb{R}} e^{-x^2} dx = \sqrt{\pi}. \quad \square$$

---

## References

- AF. A. Andreotti, T. Frankel: *The Lefschetz theorem on hyperplane sections*, Ann. of Math. **69**(1953), 713–717.
- Ar1. V.I. Arnold: *Mathematical Methods of Classical Mechanics*, Graduate Texts in Math., vol. 60, Springer-Verlag, 1989.
- AGV1. V.I. Arnold, S.M. Gusein-Zade, A.N. Varchenko: *Singularities of Differentiable Maps. Vol. I*, Monographs in Math., vol. 82, Birkhäuser, 1985.
- AGV2. V.I. Arnold, S.M. Gusein-Zade, A.N. Varchenko: *Singularities of Differentiable Maps. Vol. II*, Monographs in Math., vol. 83, Birkhäuser, 1985.
- A. M.F. Atiyah: *Convexity and commuting Hamiltonians*, Bull. London Math. Soc., **14**(1982), 1 -15.
- AB1. M.F. Atiyah, R. Bott: *Yang-Mills equations over Riemann surfaces*, Phil. Trans.R. Soc. London A, **308**(1982), 523 -615.
- AB2. M.F. Atiyah, R. Bott: *The moment map and equivariant cohomology*, Topology, **23**(1984), 1 -28.
- Au. M. Audin: *Torus Actions on Symplectic Manifolds*, 2nd edition, Birkhäuser, 2005.
- ABr. D.M. Austin, P.J. Braam: *Morse–Bott theory and equivariant cohomology*, *The Floer Memorial Volume*, p. 123–183, Progr. in Math., 133, Birkhäuser, Basel, 1995
- BaHu. A. Banyaga, D. Hurtubise: *Lectures on Morse Homology*, Kluwer Academic Publishers, 2005.
- BGV. N. Berline, E. Getzler, M. Vergne: *Heat Kernels and Dirac Operators*, Springer Verlag, 2004.
- Bo. A. Borel: *Seminar of Transformation Groups*, Annals of Math. Studies, vol. 46, Princeton University Press, 1960.
- B1. R. Bott: *Nondegenerate critical manifolds*, Ann. of Math., **60**(1954), 248–261.
- B2. R. Bott: *Lectures on Morse theory, old and new*, Bull. Amer. Math. Soc. (N.S.) **7**(1982), 331–358.
- B3. R. Bott: *Morse theory indomitable*, Publ. IHES, **68**(1988), 99–114.
- BT. R. Bott, L. Tu: *Differential forms in Algebraic Topology*, Springer-Verlag, 1982.
- BK. L. Bröcker, M. Kuppe: *Integral geometry of tame sets*, Geom. Dedicata, **82**(2000), 285–323.

- BZ. Yu.D. Burago, V.A. Zalgaller: *Geometric Inequalities*, Springer Verlag, 1988.
- BFK. D. Burghelca, L. Friedlander, T. Kappeler: *On the space of trajectories of a generic gradient-like vector field*, arXiv: 1101.0778
- Ch. S.S. Chern: *Complex Manifolds Without Potential Theory*, Springer-Verlag, 1968, 1995.
- CL. S.S. Chern, R. Lashof: *On the Total Curvature of immersed Manifolds*. Amer. J. Math., **79**(1957), 306-318.
- CJS. R. L. Cohen, J.D.S. Jones, G.B. Segal: *Morse theory and classifying spaces*, preprint, 1995.  
<http://math.stanford.edu/~ralph/morse.ps>
- Co. P. Conner: *On the action of the circle group*, Michigan Math. J., **4**(1957), 241–247.
- Del. T. Delzant: *Hamiltoniens périodiques et images convexes de l'application moment*, Bulletin de la Soc. Math. Fr., **116**(1988), 315-339.
- Do. A. Dold: *Lectures on Algebraic Topology*, Springer-Verlag, 1980.
- DH. J.J. Duistermaat, G.J. Heckman: *On the variation in the cohomology of the symplectic form of the reduced phase space*, Invent. Math. **69**(1982), 259-268.
- DV. I.A. Dynnikov, A.P. Vesselov: *Integrable Morse flows*, St. Petersburg Math. J., **8**(1997), 78-103. [math.dg-ga/956004](http://math.dg-ga/956004).
- Ehr. Ch. Ehresmann: *Sur l'espaces fibrés différentiables*, C.R. Acad. Sci. Paris, **224**(1947), 1611–1612.
- Fa. M. Farber: *Invitation to Topological Robotics*, European Mathematical Society, 2008.
- FaSch. M. Farber, D. Schütz: *Homology of planar polygon spaces*, Geom. Dedicata, **125**(2007), 75-92; arXiv: [math.AT/0609140](http://arxiv.org/abs/math/0609140).
- Fed. H. Federer: *Geometric Measure Theory*, Springer-Verlag, 1969.
- Fl. A. Floer: *Witten's complex and infinite-dimensional Morse theory*, J. Differential Geom. **30**(1989), 207–221.
- Fra. T. Frankel: *Fixed points and torsion on Kähler manifolds*, Ann. of Math. **70**(1959), 1–8.
- GKZ. I.M. Gelfand, M.M. Kapranov, A.V. Zelevinski: *Discriminants, Resultants and Multidimensional Determinants*, Birkhäuser, 1994.
- GWPL. C.G. Gibson, K. Wirthmüller, A.A. du Plessis, E.J.N. Looijenga: *Topological Stability of Smooth Mappings*, Lect. Notes in Math., vol. 552, Springer Verlag, 1976.
- GG. M. Golubitsky, V. Guillemin: *Stable Mappings and Their Singularities*, Graduate Texts in Math., vol. 14, Springer Verlag, 1973.
- GKM. M. Goresky, R. Kottwitz, R. MacPherson: *Equivariant cohomology, Koszul duality and the localization theorem*, Invent. Math. **131**(1998), 25–83.
- GH. P. Griffiths, J. Harris: *Principles of Algebraic Geometry*, John Wiley & Sons, 1978.
- Gu. M. Guest: *Morse theory in the 1990's*,  
<http://www.comp.metro-u.ac.jp/~martin/RESEARCH/new.html>
- GS. V. Guillemin, S. Sternberg: *Convexity properties of the moment map*, Invent. Math., **97**(1982), 485-522.
- GS1. V. Guillemin, S. Sternberg: *Supersymmetry and Equivariant deRham Theory*, Springer Verlag, 1999.



- HL. F.R. Harvey, H.B. Lawson: *Morse theory and Stokes' theorem*, Surveys in differential geometry, 259–311, Surv. Differ. Geom., VII, Int. Press, Somerville, MA, 2000.  
<http://www.math.sunysb.edu/~blaine/>
- Ha. A. Hatcher: *Algebraic Topology*, Cambridge University Press, 2002.  
<http://www.math.cornell.edu/~hatcher/AT/ATpage.html>
- Hau. J.-C. Hausmann: *Sur la topologie des bras articulés*, in the volume *Algebraic Topology 1989 Poznan. Proceedings*, S. Jackowski, B. Oliver, K. Pawalowski, Lect. Notes in Math., vol. 1474, 146–169.
- Helg. S. Helgason: *Differential Geometry, Lie Groups, and Symmetric Spaces*, Graduate Studies in Math. v. 34, Amer. Math. Soc., 2001.
- Hir. M. Hirsch: *Differential Topology*, Springer-Verlag, 1976.
- H3. L. Hörmander: *The Analysis of Linear Partial Differential Operators III. Pseudo-differential Operators*, Springer Verlag, 1994.
- Hs. W.-Y. Hsiang: *Cohomological Theory of Compact Transformation Groups*, Springer-Verlag, 1975.
- HZ. S. Hussein-Zade: *The monodromy groups of isolated singularities of hypersurfaces*, Russian Math. Surveys, **32:2**(1977), 23–69.
- KM. M. Kapovich, J. Millson: *On the moduli space of polygons in the Euclidean plane*, J. Diff. Geom., **42**(1995), 430–464.
- KrMr. P. Kronheimer, T. Mrowka: *Monopoles and 3-Manifolds*, Cambridge University Press, 2007.
- Lam. K. Lamotke: *The topology of complex projective varieties after S. Lefschetz*, Topology, **20**(1981), 15–51.
- Lau. F. Laudenbach: *On the Thom–Smale complex*, Astérisque, vol. 205(1992), Soc. Math. France.
- Lef. S. Lefschetz: *L'Analysis Situs et la Géométrie Algébrique*, Gauthier Villars, Paris, 1924.
- Lo. E.J.N. Looijenga: *Isolated Singular Points on Complete Intersections*, London Math. Soc. Lect. Note Series, vol. 77, Cambridge University Press, 1984.
- Mac. S. Mac Lane: *Homology*, Classics in Mathematics, Springer-Verlag, 1995.
- Mat. J. Mather: *Notes on Topological Stability*,  
<http://www.math.princeton.edu/facultypapers/mather/>
- McS. D. McDuff, D. Salamon: *Introduction to Symplectic Topology*, Oxford University Press, 1995.
- M0. J.W. Milnor: *On the total curvature of knots*, Ann. Math., **52**(1950), 248–257.
- M1. J.W. Milnor: *Manifolds homeomorphic to the 7-sphere*, Ann. Math. **64**(1956), 399–405.
- M2. J.W. Milnor: *Topology from a Differentiable Viewpoint*, Princeton Landmarks in Mathematics, 1997.
- M3. J.W. Milnor: *Morse Theory*, Ann. Math Studies, vol. 51, Princeton University Press, 1973.
- M4. J.W. Milnor: *Lectures on the h-cobordism*, Princeton University Press, 1965.
- MS. J. Milnor, J.D. Stasheff: *Characteristic Classes*, Ann. Math. Studies 74, Princeton University Press, Princeton, 1974.
- Mor. F. Morgan: *Geometric Measure Theory. A Beginner's Guide*, Academic Press, 2000.

- Ni1. L.I. Nicolaescu: *Lectures on the Geometry of Manifolds*, 2nd Edition, World Scientific, 2007.
- Ni2. L.I. Nicolaescu: *Tame Flows*, Mem. A.M.S., vol. 208, n.980, American Mathematical Society, 2010.
- Ni3. L.I. Nicolaescu: *Critical sets of random smooth functions on compact manifolds*, arXiv:1008.5085, Asian J. Math., **19**(2015), 391-432.
- PT. R. Palais, C. Terng: *Critical Point Theory and Submanifold Geometry*, Lect. Notes in Math., vol. 1353, Springer Verlag, 1988.
- Pf. M.J. Pflaum: *Analytic and Geometric Study of Stratified Spaces*, Lect. Notes Math., vol. 1768, Springer Verlag, 2001.
- Qin. L. Qin: *On moduli spaces and CW structures arising from Morse Theory on Hilbert manifolds*, Journal of Topology and Analysis, **2**(2010), 469-526, arXiv: **1012.3643**.
- Re. G. Reeb: *Sur les points singuliers d'une forme de Pfaff complètement intégrable ou d'une fonction numérique*, C. R. Acad. Sci. Paris, **222**(1946), 847-849.
- RS. M. Reed, B. Simon: *Methods of Modern Mathematical Physics II: Fourier Analysis and Selfadjointness*, Academic Press, 1975.
- Rolf. D. Rolfsen: *Knots and Links*, Publish or Perish, 1976.
- RoSa. C.P. Rourke, B.J. Sanderson: *Introduction to Piecewise-Linear Topology*, Springer Verlag, 1982.
- Sal. D. Salamon: *Morse theory, the Conley index and Floer homology*, Bull. London Math. Soc., **22**(1990), 113-140.
- Sch. M. Schwarz: *Morse Homology*, Birkhäuser, 1993.
- S. J.-P. Serre: *Local Algebra*, Springer-Verlag, 2000.
- SV. D. Shimamoto, C. Vanderwaart: *Spaces of polygons in the plane and Morse theory*, Amer. Math. Monthly, **112**(2005), 289-310.
- Sm. S. Smale: *On gradient dynamical systems*, Ann. of Math., **74**(1961), 199-206.
- Spa. E.H. Spanier: *Algebraic Topology*, Springer Verlag, 1966.
- Str. D.J. Struik: *Lectures on Classical Differential Geometry*, 2nd edition, Dover Publications, 1988.
- Th. R. Thom: *Sur une partition en cellules associées á une fonction sur une variété*, C.R. Acad. Sci Paris, **228**(1949), 973-975.
- Tr. D. Trotman: *Geometric versions of Whitney regularity conditions*, Ann. Scien. Éc. Norm. Sup., **4**(1979), 453-463.
- W. H. Whitney: *Geometric Integration Theory*, Princeton University Press, 1957.
- Wit. E. Witten: *Supersymmetry and Morse theory*, J. Differential Geom., **17**(1982), 661-692.

---

## Index

- $BS^1$ , 160
- $C(p, q)$ , 221
- $DF_x$ , 1
- $E(1)$ , 248
- $H_{f,x_0}$ , 6
- $I_\omega$ , 129
- $L_{\mathbb{T}}$ , 144
- $M_f(t)$ , 7
- $PD_M$ , 249
- $S < S'$ , 204
- $S^1$ -map, 163
- $S^1$ -space, 163
  - finite type, 168
  - negligible, 169
- $S_p^\pm(\varepsilon)$ , 64
- $TM^{0,1}$ , 114
- $TM^{1,0}$ , 114, 123
- $T^*M^{0,1}$ , 115
- $T^*M^{1,0}$ , 115
- $T_S M$ , XI
- $T_\Sigma X$ , 40
- $W_p^+$ , 65
- $W_p^-$ , 65
- $W_p^\pm$ , 64
- $W_n$ , 96
- $W_n(\mathbf{r})$ , 96
- $W_n^*$ , 96
- $X \perp$ , XI
- $X >_S$ , 204
- $[f]$ , 13
- $\mathbf{Cr}_F$ , 1
- $\mathbf{Cr}_f(p, q)$ , 232
- $\Delta_F$ , 1
- $\text{End}(E)$ , XI, 112
- $\text{Fix}_G(M)$ , 140
- $\Gamma_p$ , 227
- $\Gamma_p^\varepsilon$ , 227
- $\text{Gr}(E)$ , 112
- $\mathcal{J}_\omega$ , 120
- $\Lambda^{p,q}T^*M$ , 115
- $\mathcal{O}(m)$ , 161
- $\Omega^{p,q}(M)$ , 115
- $\Sigma(2, 3, 5)$ , 39
- $\text{Vect}(M)$ , XI
- $\mathbb{C}[z]$ -module
  - finitely generated, 169
  - support of, 169
  - negligible, 169
- $\mathbb{D}^k$ , 31
- $\mathbb{U}_1$ , 161
- $\mathbb{U}_n$ , 161
- $\mathcal{S}_p^\pm$ , 226
- $\text{cat}_M$ , 92
- $\text{Diag}(c_1, \dots, c_n)$ , XII
- $\mathcal{L}_S$ , 209
- $\mathcal{L}_S(X)$ , 209
- $\mathcal{M}_{\mathbf{r}}$ , 96
- $\mathcal{S}_V(U)$ , 195
- $\mathbf{i}$ , XI
- $\kappa(s)$ , 28
- $\lambda(f, S)$ , 80
- $\lambda(f, p_0)$ , 7
- $\mathbf{lk}$ , 34
- $L^{k,2}$ , 36
- $\mu_f(\lambda)$ , 7
- $\nabla^\omega H$ , 130

- $\mathfrak{h}$ , XI
- $\succ$ , 55
- $\mathbb{K}^r$ , XI
- $\mathfrak{so}(n)$ , XII
- $\mathfrak{so}_J(M)$ , 139
- $u(n)$ , XII, 128
- $b_k(X)$ , 56
- $e_\lambda(p)$ , 45, 57, 58
- $i^!$ , 260
- $i_X$ , XI
- $i_!$ , 258
- $x^\alpha$ , 13
- $\mathbb{P}(d, N)$ , 244
- $\text{var}_\gamma$ , 280
- $\text{CL}(M)$ , 92
- adapted
  - coordinates, 16, 43, 225
  - adapted metric, 43
  - Alexander cohomology, 93
  - almost complex structure, *see* structure
  - area formula, 28
- Betti number, 261, 263
- Betti numbers, 56
- blowup, 248
  - radial, 228
- broken trajectories, 240
- Cartan formula, 130
- cell, 31
- chain, 232
  - length, 232
  - maximal, 232
- character, 300
- classifying space, 161
- co-orientation, 234
- coadjoint orbit, 125, 135
- coarea formula, 24
- cohomology
  - De Rham, 280, 301
  - equivariant, 164
  - singular, 150
- concatenation, 224
  - approximate, 231
- connector, 221, 234
- conormal space, 152
- controlled tube system, 208
- critical point, 1, 254
  - Bott-Samelson type, 102
  - hessian, 6
  - index, 7
  - nondegenerate, 6
- critical value, 1
- crookedness, 28
- cuplength, 92
- curve, 2
  - cubic
    - pencil, 248
- cycle
  - effective, 262
  - invariant, 257, 283
  - primitive, 262
  - vanishing, 256, 267, 283
- Dehn twist, 282
- divisor, 244
- duality
  - Poincaré, 249, 258
  - Poincaré–Lefschetz, 76, 98, 271
- Eilenberg–Mac Lane space, 168
- elliptic fibration, 248
- ENR, 168
- Euclidean space, XI
- Euler
  - characteristic, 56
  - class, 162, 273
- fibration
  - homotopy lifting property, 265
  - Lefschetz, 250
- finite type, 168
- five lemma, 257
- flag, 128
  - manifold, 128
- flow, 44, 53, 62, 66, 75, 129, 274
  - descending, 62
  - Hamiltonian, 130
  - Morse–Smale, 77
  - Morse–Smale, 210
  - Morse–Whitney, 210
- Fourier
  - inversion formula, 177
  - transform, 177
- framing, 32
- Fubini–Study form, 124, 299, 325

- gap condition, 59
- Gauss lemma, 172
- gaussian, 29, 286
- genus formula, 253
- germ, 13
- graded vector space, 54
  - admissible, 54
- gradient, 43
- Grassmannian, 107, 112, 128
- group
  - action, 124, 125, 133, 163
    - dual right, 163
    - effective, 124, 138, 157
    - fixed point set of, 140, 144, 169, 174
    - Hamiltonian, 133, 140, 144, 174
    - left, 163
    - quasi-effective, 143
    - right, 163
    - symplectic, 133
  - Lie, *see* Lie
- Gysin
  - map, 163
  - sequence, 163
- Hamilton equations, 131
- Hamiltonian, 130
  - vector field, 130
- Hamiltonian action, *see* group
- handle, 39
  - cocore, 39
  - core, 39
  - index of, 39, 49
- handlebody, 72
- harmonic oscillator, 131, 134
- Heegard decomposition, 72
- Hessian, 99
- hessian, 6
- Hodge theory, 260
- homogeneous space, 124
- homology equation, 12
- homology sphere, 39
- homotopy method, 12
- Hopf bundle, 161
- Hopf link, 34
- Hopf surface, 261
- index, 7
- index theory, 86
- intersection form, 258
- Jacobi identity, 127
- Jacobian, 24
- Jacobian ideal, 14
- Key Lemma, 253, 255
- knot, 24, 33
  - diagram, 36
  - crossings, 37
  - group
    - Wirtinger presentation, 36
  - group of, 36
  - longitude of, 34
  - meridian of, 34
  - parallel, 36
    - blackboard, 37
  - trefoil, 36
- Kronecker pairing, 76, 249, 258, 271
- Lagrangian
  - submanifold, 298
    - exact, 298
    - subspace, 297
- lattice, 300
- Lefschetz decomposition, 262
- lemma
  - Hadamard, 13
- length vector, 95
  - ordered, 97
- Lie
  - algebra, 125, 128
  - group, 125, 134, 136
    - adjoint representation, 125
    - coadjoint action, 125
- line bundle, 160
  - associated, 160
  - universal, 161
- linear system, 244
  - base locus of, 244, 249
- linkage, 3
- linking number, 34
- local transversal, 209
- Lusternik–Schnirelmann
  - category, 92
- manifold, 1
  - algebraic, 113, 119, 124, 249
    - modification of, 244
  - complex, 114, 123
  - Kähler, 123

- stable, 64
- Stein, 113
- symplectic, 121, 124
- unstable, 64
- with corners, 225
- map
  - critical point of, 1
  - critical set of, 1
  - critical value of, 1
  - degree of, 253
  - differential of, 1
  - discriminant set of, 1
  - regular point of, 1
  - regular value of, 1
  - variation, 270
- Mayer–Vietoris sequence, 171
- min-max
  - data, 83
  - principle, 84
  - theory, 83
- moment map, 133
- monodromy, 270
  - group, 282, 283
  - homological, 270
  - local, 267, 270
  - relative, 270
- Morse
  - coindex, 80
  - function, 6, 18, 62, 65, 246, 264
    - completable, 58
    - excellent, 22
    - exhaustive, 21, 42
    - metric adapted to a, 43
    - nonresonant, 22, 65
    - perfect, 58, 62, 139, 294
    - resonant, 22
    - self-indexing, 69
  - index, 80, 174
  - inequalities, 56
    - abstract, 55
    - weak, 55
  - lemma, 12, 16, 179
    - with parameters, 80
  - number, 7
  - polynomial, 7, 56, 80
- Morse–Bott
  - function, 79, 140, 145
    - completable, 82
    - perfect, 82, 111, 160, 174
  - inequalities, 81, 174
  - polynomial, 80
- Morse–Smale
  - pair, 69
  - vector field, 69
- Morse–Floer complex, 76, 234
- Mountain-pass
  - Lemma, 86
  - points, 85
- moving frame, 26
- negligible
  - $\mathbb{C}[z]$ -module, 169
  - $S^1$ -space, 169, 171
  - set, 1, 20
- normal bundle
  - negative, 80
- Palais–Smale condition, 21
- pencil, 244
  - Lefschetz, 245, 249
    - monodromy group, 282
    - monodromy of, 280
- phase space
  - classical, 122
- Picard–Lefschetz
  - global formula, 280, 283
  - local formula, 273
  - number, 271
- planar polygons
  - moduli space of, 96
- Poincaré
  - dual, 162, 257
  - series, 54, 112
  - sphere, 39, 62
- Poisson bracket, 131
- polyhedron
  - convex, 152
- projection, 253
  - axis of, 246
  - screen of, 246
- projection formula, 249
- projective space, 243
  - dual of, 243
- regular value, 1
- Riemann–Lebesgue lemma, 175
- robot arm, 3, 8, 50
  - configuration, 3

- shadow, 195
- short subset, 97
- spectral sequence, 74
  - Leray–Serre, 168
- stabilizer, 125, 143
- standard model, 122, 269
- stationary phase, 175
- Stein manifold, 113
- stratum, 203
- structure
  - almost complex, 114
    - $G$ -tamed, 135
    - tamed, 120
- subadditivity, 55
- submersion, 268
- surgery, 31, 32
  - attaching sphere, 33
  - coefficient, 34
  - trace of, 42, 51
  - type of, 32
- symplectic
  - duality, 121, 129
  - form, 120
  - gradient, 130
  - manifold, 121
    - toric, 156
  - orientation, 121
  - pairing, 120
    - basis adapted to, 120
  - space, 120
  - structure, 121
  - volume form, 121
- theorem
  - hard Lefschetz, 260
  - Andreotti–Frankel, 113
  - Arnold–Liouville, 330
  - Bott, 80
  - Conner, 173
  - Darboux, 124, 151
  - Duistermaat–Heckman, 179
  - Ehresmann fibration, 248, 252, 255, 265, 268, 328
  - equivariant localization, 169, 185
  - excision, 249, 255, 265
  - Fenchel, 29
  - fundamental structural, 45, 80, 151
  - Gauss–Bonnet–Chern, 162
  - Gysin, 163
  - Künneth, 104, 250
  - Lefschetz
    - hard, 262
  - Lefschetz hyperplane, 119, 254, 256, 260
  - Lusternik–Schnirelmann, 92
  - moment map convexity, 144
  - Morse–Sard–Federer, 2, 19
  - Poincaré–Lefschetz, 76, 98, 119, 271
  - Sard, 25
  - Thom first isotopy, 207
  - Thom isomorphism, 81, 150
  - universal coefficients, 257, 258
  - van Kampen, 35
  - weak Lefschetz, 258, 259
  - Whitney embedding, 16, 21
- thimble, 267, 280
- Thom
  - class, 81, 162
  - first isotopy theorem, 207
  - isomorphism, 81, 163
- Thom–Smale complex, 75
- total curvature, 28
- tube, 201
  - width function, 201
- tubular neighborhood, 201
- tunneling, 75, 222, 234
  - broken, 223
  - map, 226
- vanishing
  - cycle, 256, 267, 280
  - sphere, 267, 280
- vector field, 5, 12, 129
  - gradient like, 42, 62
  - Hamiltonian, 130
- Veronese embedding, 245
- Whitney
  - condition, 198
  - stratification, 203
  - umbrella, 198
- Wirtinger presentation, 36
- writhe, 37