

Math 10360 Review for Exam 1

1. Treating the stated variable as a constant, find the given derivative

(a) y ; $\frac{d}{dx} \left(\frac{e^{2x+y}}{4 + e^{x-3y}} \right)$ Answer: $\frac{8e^{2x+y} + e^{3x-2y}}{(4 + e^{x-3y})^2}$

(b) x ; $\frac{d}{dy} \left(\frac{e^{2x+y}}{4 + e^{x-3y}} \right)$ Answer: $\frac{4e^{2x+y} + 4e^{3x-2y}}{(4 + e^{x-3y})^2}$

2. The population (in thousands) of a certain kind of antelope is modeled by $\frac{dp}{dt} = \frac{12}{t^2 + 4}$. Find the total change in the size of the population over the interval $0 \leq t \leq 2$ years. Answer: $3\pi/2$

3. It was observed that a radioactive substance reduces its mass from 10 grams to 2 grams after 3 hours. (a) Find a formula for its mass $y(t)$ after t hours, (b) What is the half-life of the radioactive substance?

Answer: (a) $y(t) = 10e^{\frac{t}{3} \ln(0.2)} = 10(0.2)^{t/3}$; (b) Half-life = $\frac{3 \ln(0.5)}{\ln(0.2)}$

4. Consider the region bounded by $y = 2x - 1$, $y = \sqrt{x}$, $x = 0$.

(a) Find the area of the region. Answer: $\int_0^1 (\sqrt{x} - 2x + 1) dx$

(b) Find the volume of the solid obtained by rotating the region about (i) $x = 6$, (ii) about $y = -1$.

Answer: (i) $\int_0^1 2\pi(6-x)(\sqrt{x} - 2x + 1) dx$; (ii) $\int_0^1 \pi[(\sqrt{x} + 1)^2 - (2x)^2] dx$

(c) Consider the solid whose base the given region. If the cross-sections perpendicular to the x -axis are isosceles triangles with height x .

Answer: $\int_0^1 \frac{1}{2}(\sqrt{x} - 2x + 1)x dx$

5. A 1600 kg. elevator is suspended by a 200 m. cable that weighs 10 kg/m. How much work is required to raise the elevator from the basement to the third floor, a distance of 30 m? You may take the acceleration due to gravity g as 10 m/s².

Answer: Measure distance y downward from top end of cable: $1600(30)g + \int_0^{30} 10gy dy + \int_{30}^{200} 300g dy$

6. Find the intersection points of $f(x) = 5 - x^2$ and $g(x) = x - 1$. Then find the area over the interval $0 \leq x \leq 3$.

Answer: $\int_0^2 [(5 - x^2) - (x - 1)] dx + \int_2^3 [(x - 1) - (5 - x^2)] dx$

7. Find the work required to pump all liquid of mass density 900 kg/m³ two meters above a cylindrical tank of radius 3m and height 10m. You may assume that the tank is completely full with the liquid. You may take the acceleration due to gravity g as 10 m/s².

Answer: Measure distance y upward from the base of the cylinder: $\int_0^{10} 900\pi g(3)^2(12 - y) dy$

8. Find the equation of the tangent line to the curve $y = \ln \left(\frac{5x^2 - 1}{x^2 + 3} \right)$ at $x = 1$. Answer: $y = 2(x - 1)$

9. The population $p(t)$ of a city is reducing exponentially with **decay constant** 0.04. Write down a differential equation which $p(t)$ satisfies. Find the time it takes for the population to reduce by half.

Answer: $\frac{dp}{dt} = -0.04p$. $p(t) = Ce^{-0.04t}$. Solve $Ce^{-0.04t} = C/2$ so $t = \frac{\ln(1/2)}{-0.04} = \frac{\ln 2}{0.04}$

10. The radial density of a circular disc of 10 cm is given by $\rho(r) = \frac{2}{\sqrt{400 - r^2}}$ gram/cm². Find the total mass of the disc.

Answer: $\int_0^{10} \frac{4\pi r}{\sqrt{400 - r^2}} dr$. Use $u = 400 - r^2$.

11. Find the equation of the tangent line to the graph of the function $f(x) = 2^x + x^2$ at $x = 1$.

Answer: $y = (2 \ln 2 + 2)x - 1$

12. It is observed that a radioactive substance starting with 5 grams reduces to 4 grams after 10 hours in a laboratory. (a) If $y(t)$ is the amount of the substance in gram after t hours, find a formula for $y(t)$. (b) What is the average amount of radioactive substance over the 10 hours duration mentioned above.

Answer: (a) $y(t) = 5e^{\frac{t}{10} \ln(0.8)} = 5e^{\ln(0.8)t/10} = 5(0.8)^{t/10}$; (b) $\frac{-1}{\ln(0.8)}$

13. Evaluate the integral $\int_0^1 x^3 e^{x^4+1} dx$.

Answer: $\int_1^2 \frac{1}{4} e^u du = \frac{1}{4}(e^2 - e)$

14. A rope 10 m long weighs 2 kg per meter is hung from a platform 30 meter above the ground. How much work is required to lift the whole rope to the top of the platform in Joules? You may take the acceleration due to gravity g as 10 m/s².

Answer: 1000 J

15. Find the volume of the solid formed by revolving the region bounded between the graph of $y = x^2$ and $y = 2 - x^2$ about the x -axis.

Answer: $\int_{-1}^1 \pi[(2 - x^2)^2 - (x^2)^2] dx$

16. Evaluate the following integrals:

(i) $\int_0^1 \frac{dx}{\sqrt{4-x^2}}$ (Ans: $\pi/6$) (

(ii) $\int_0^{\sqrt{\pi}/2} x \cos(x^2) dx$ (Ans: $\frac{\sqrt{2}}{4}$)

(iii) $\int \frac{3+2x}{9+4x^2} dx$ (Ans: $\frac{1}{2} \arctan\left(\frac{2x}{3}\right) + \frac{1}{4} \ln(9+4x^2) + C$)

Math 10360: Calculus B
Exam I Sample
February 12, 2035

Name: _____

Class Time: _____

- The Honor Code is in effect for this examination. All work is to be your own.
- No calculators.
- The exam lasts for one hour and 15 minutes.
- Be sure that your name is on every page in case pages become detached.
- Be sure that you have all 10 pages of the test.

Honor pledge. “As a member of the Notre Dame community, I will not participate in or tolerate academic dishonesty.”:

Good Luck!

| | | | | | |
|---|----------------------------|----------------------------|----------------------------|----------------------------|----------------------------|
| PLEASE MARK YOUR ANSWERS WITH AN X, not a circle! | | | | | |
| 1. | <input type="checkbox"/> a | <input type="checkbox"/> b | <input type="checkbox"/> c | <input type="checkbox"/> d | <input type="checkbox"/> e |
| 2. | <input type="checkbox"/> a | <input type="checkbox"/> b | <input type="checkbox"/> c | <input type="checkbox"/> d | <input type="checkbox"/> e |
| 3. | <input type="checkbox"/> a | <input type="checkbox"/> b | <input type="checkbox"/> c | <input type="checkbox"/> d | <input type="checkbox"/> e |
| 4. | <input type="checkbox"/> a | <input type="checkbox"/> b | <input type="checkbox"/> c | <input type="checkbox"/> d | <input type="checkbox"/> e |
| 5. | <input type="checkbox"/> a | <input type="checkbox"/> b | <input type="checkbox"/> c | <input type="checkbox"/> d | <input type="checkbox"/> e |
| 6. | <input type="checkbox"/> a | <input type="checkbox"/> b | <input type="checkbox"/> c | <input type="checkbox"/> d | <input type="checkbox"/> e |
| 7. | <input type="checkbox"/> a | <input type="checkbox"/> b | <input type="checkbox"/> c | <input type="checkbox"/> d | <input type="checkbox"/> e |
| 8. | <input type="checkbox"/> a | <input type="checkbox"/> b | <input type="checkbox"/> c | <input type="checkbox"/> d | <input type="checkbox"/> e |
| 9. | <input type="checkbox"/> a | <input type="checkbox"/> b | <input type="checkbox"/> c | <input type="checkbox"/> d | <input type="checkbox"/> e |
| 10. | <input type="checkbox"/> a | <input type="checkbox"/> b | <input type="checkbox"/> c | <input type="checkbox"/> d | <input type="checkbox"/> e |

| | |
|---|-------|
| Please do NOT write in this box. | |
| Multiple Choice | _____ |
| 11. | _____ |
| 12. | _____ |
| 13. | _____ |
| 14. | _____ |
| Total | _____ |

Name: _____

Class Time: _____

Multiple Choice

1.(5 pts.) Consider a radioactive isotope that reduces exponentially with decay constant $\frac{1}{20}$ hours⁻¹. If the initial amount of the isotope is 10 grams, find its **average** amount over the first 10 hours.

- (a) $100 - 100e^{-1/2}$ grams.
- (b) $1 - e^{-1/2}$ grams.
- (c) $10 - 10e^{-1/2}$ grams.
- (d) $200 - 200e^{-1/2}$ grams.
- (e) $20 - 20e^{-1/2}$ grams.

2.(5 pts.) Perform the integral:

$$\int \frac{x^4 - 3x^2 + 2x}{x^2} dx$$

- (a) $\frac{\frac{x^5}{5} - x^3 + x^2 + C}{\frac{x^3}{3} + C}$
- (b) $\frac{x^3}{3} - 3x + 2 \ln |x| + C$
- (c) $\frac{4x^3 - 6x + 2}{2x} + C$
- (d) $2x - \frac{2}{x^2} + C$
- (e) $\frac{\frac{x^5}{5} - x^3 + x^2}{\frac{x^3}{3}} + C$

Name: _____

Class Time: _____

3.(5 pts.) The areas enclosed between the curves $x = f(y)$ and $x = g(y)$ are given below. The **bold** curve is $x = g(y)$. Find the value of the integral $\int_1^4 [g(y) - f(y)] dy$.

- (a) 5
- (b) -11
- (c) 24
- (d) 11
- (e) -5

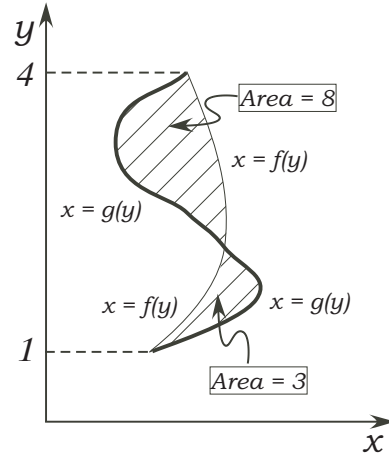

4.(5 pts.) Find the total mass of the a $(1/2)$ -meter rod whose linear density function is $\rho(x) = \frac{2}{\sqrt{1-x^2}}$ kg/m for $0 \leq x \leq 1/2$.

- (a) $\frac{\pi}{3}$ kg.
- (b) $\frac{\pi}{2}$ kg.
- (c) $\frac{\pi}{6}$ kg.
- (d) π kg.
- (e) $\frac{\pi}{4}$ kg.

Name: _____

Class Time: _____

5.(5 pts.) Find the equation of the tangent line to the graph of the function

$$f(x) = 2^x + x^2$$

at $x = 1$.

- (a) $y + 3 = (2 \ln 2 + 2)(x + 1)$
- (b) $y - 3 = (2^x \ln 2 + 2x)(x - 1)$
- (c) $y + 3 = (2^x \ln 2 + 2x)(x + 1)$
- (d) $y - 3 = (2 \ln 2 + 2)(x - 1)$
- (e) $y - 1 = (2 \ln 2 + 2)(x - 3)$

6.(5 pts.) The position function of a particle moving on a straight line is given by

$$s(t) = \ln \left(\frac{2t + 1}{t + 2} \right)$$

where s is in meters and t is in minutes. Find the exact value of the instantaneous velocity of the particle when $t = 1$ minute.

- (a) $\frac{2}{3}$ m/min.
- (b) $\frac{1}{3}$ m/min.
- (c) 0 m/min.
- (d) 2 m/min.
- (e) 1 m/min.

Name: _____

Class Time: _____

7.(5 pts.) Find the derivative of the function

$$y = x \arcsin(2x).$$

(a) $\frac{2}{\sqrt{1-4x^2}}$

(b) $\frac{x}{1+4x^2} + \arcsin(2x)$

(c) $2x \arccos(2x) + \arcsin(2x)$

(d) $\frac{2x}{\sqrt{1-4x^2}} + \arcsin(2x)$

(e) $\frac{x}{\sqrt{1-2x^2}} + \arcsin(2x)$

8.(5 pts.) Consider the solid whose base is given by the shaded region below the line $y = x$. Find the volume of the solid if the cross-sections perpendicular to the x -axis are **triangles** of height $2x$.

(a) $\frac{8}{3}$

(b) 4

(c) 1

(d) 8

(e) $\frac{16}{3}$

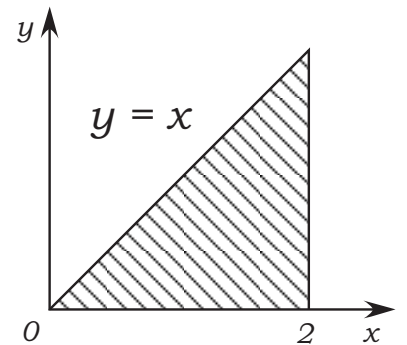

Name: _____

Class Time: _____

9.(5 pts.) Which of the following expressions is the result of applying the substitution with $u = x^2 + 2x + 5$ to evaluate the integral $\int_0^1 (x + 1) \tan [(x^2 + 2x + 5)^2] dx$?

(a) $\frac{1}{2} \int_0^1 \tan(u^2) du$

(b) $\int_5^8 \tan(u^2) du$

(c) $\int_5^8 (\sqrt{u-4}) \tan(u^2) du$

(d) $\frac{1}{2} \int_5^8 \tan(u^2) du$

(e) $\int_0^1 \tan(u^2) du$

10.(5 pts.) Using **washers (or disk) method**, which of the integrals below gives the volume of the solid obtained when the finite region between $y = x^2 - 2$, $y = -1$ is revolved about the line $y = -1$.

(a) $\int_{-2}^{-1} 2\pi(2 + y) dy$

(b) $\int_{-1}^1 \pi[(2 - x^2)^2 - 1] dx$

(c) $\int_{-1}^1 \pi(1 - x^2)^2 dx$

(d) $\int_{-1}^1 2\pi x(1 - x^2) dx$

(e) $\int_{-2}^{-1} 2\pi x(1 - x^2) dx$

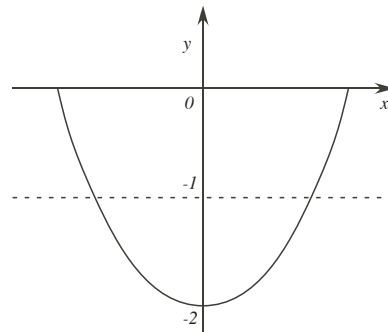

Name: _____

Class Time: _____

Partial Credit

You must show your work on the partial credit problems to receive credit!

11.(12 pts.) A 10 meter long tank has cross-section given by the figure below. If the tank is filled to **three quarter the depth** of the tank with fluid of density 500 kg/m^3 , what is the work required to pump all the fluid to the top of the tank.

You may take the acceleration due to gravity g as 10 m/s^2 .

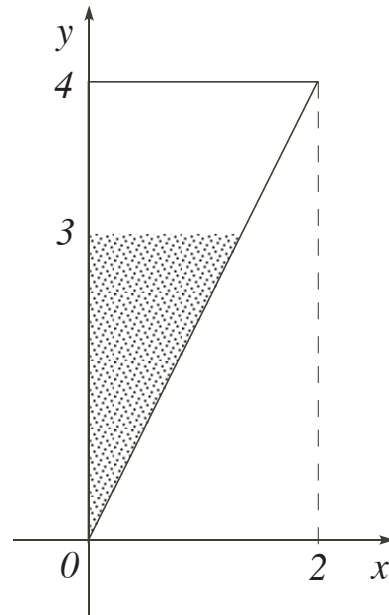

Name: _____

Class Time: _____

12.(12 pts.)

Part A. It is observed that a radioactive substance starting with 5 grams reduces to 4 grams after 10 hours in a laboratory. If $y(t)$ is the amount of the substance in gram after t hours, find a formula for $y(t)$. **You should explain how you arrive at your answer.**

Part B. [Unrelated to Part A] Find the area between the graphs $y = 1$ and $y = e^x$ for $-1 \leq x \leq 1$.

Name: _____

Class Time: _____

13.(12 pts.) **Part A.** Find the exact volume of the solid generated by revolving the region bounded by the graphs $y = \sqrt{x}$, $y = 0$, and $x = 2$ about the following axes:

(i) x -axis.

(ii) $x = -1$

Part B. [Unrelated to Part A] Consider the solid with base the region bounded by the graphs $y = \sqrt{x}$, $y = 0$, and $x = 2$. If the cross-section of the solid perpendicular to the x -axis are rectangles of height x^2 , find the exact volume of the solid.

Name: _____

Class Time: _____

14.(12 pts.)

Part A. The population density of monkeys measured from the center of a nature reserve is given by the radial function

$$\rho(r) = \frac{1}{(1 + r^2)^2},$$

where r is the distance from the center of the reserve measured in kilometers, and ρ is in thousands per km^2 . Find the the number of monkeys (in thousand) within a 2 km radius from the center of the reserve.

Part B. [Unrelated to Part A] A 20 m rope hangs from the top of a 50 m platform as shown below. Assuming that the rope is uniform and with mass 40 kg, find the work required to lift the upper quarter portion of the rope to the top of the platform.

You may take the acceleration due to gravity g as 10m/s^2 .

Math 10360: Calculus B
Exam I Sample
February 12, 2035

Name: _____

Class Time: ANSWERS

- The Honor Code is in effect for this examination. All work is to be your own.
- No calculators.
- The exam lasts for one hour and 15 minutes.
- Be sure that your name is on every page in case pages become detached.
- Be sure that you have all 10 pages of the test.

Honor pledge. “As a member of the Notre Dame community, I will not participate in or tolerate academic dishonesty.”:

Good Luck!

| | | | | | |
|---|-------------------------------------|-------------------------------------|-------------------------------------|-------------------------------------|-------------------------------------|
| PLEASE MARK YOUR ANSWERS WITH AN X, not a circle! | | | | | |
| 1. | <input type="checkbox"/> a | <input type="checkbox"/> b | <input type="checkbox"/> c | <input type="checkbox"/> d | <input checked="" type="checkbox"/> |
| 2. | <input type="checkbox"/> a | <input checked="" type="checkbox"/> | <input type="checkbox"/> c | <input type="checkbox"/> d | <input type="checkbox"/> e |
| 3. | <input type="checkbox"/> a | <input type="checkbox"/> b | <input type="checkbox"/> c | <input type="checkbox"/> d | <input checked="" type="checkbox"/> |
| 4. | <input checked="" type="checkbox"/> | <input type="checkbox"/> b | <input type="checkbox"/> c | <input type="checkbox"/> d | <input type="checkbox"/> e |
| 5. | <input type="checkbox"/> a | <input type="checkbox"/> b | <input type="checkbox"/> c | <input checked="" type="checkbox"/> | <input type="checkbox"/> e |
| 6. | <input type="checkbox"/> a | <input checked="" type="checkbox"/> | <input type="checkbox"/> c | <input type="checkbox"/> d | <input type="checkbox"/> e |
| 7. | <input type="checkbox"/> a | <input type="checkbox"/> b | <input type="checkbox"/> c | <input checked="" type="checkbox"/> | <input type="checkbox"/> e |
| 8. | <input checked="" type="checkbox"/> | <input type="checkbox"/> b | <input type="checkbox"/> c | <input type="checkbox"/> d | <input type="checkbox"/> e |
| 9. | <input type="checkbox"/> a | <input type="checkbox"/> b | <input type="checkbox"/> c | <input checked="" type="checkbox"/> | <input type="checkbox"/> e |
| 10. | <input type="checkbox"/> a | <input type="checkbox"/> b | <input checked="" type="checkbox"/> | <input type="checkbox"/> d | <input type="checkbox"/> e |

Please do NOT write in this box.

Multiple Choice _____

11. _____

12. _____

13. _____

14. _____

Total _____

Partial Credit

You must show your work on the partial credit problems to receive credit!

11.(12 pts.) A 10 meter long tank has cross-section given by the figure below. If the tank is filled to **three quarter the depth** of the tank with fluid of density 500 kg/m^3 , what is the work required to pump all the fluid to the top of the tank.

You may take the acceleration due to gravity g as 10 m/s^2 .

Work done to pump "slice" to the top of the tank =

$$\Delta W = (\text{Force}) \cdot (\text{Displacement})$$

$$= (\text{Weight of "slice"}) (4-y)$$

$$= (\text{Vol.}) \left(\frac{\text{weight}}{\text{density}} \right) (4-y)$$

$$= (10 \cdot L \cdot \Delta y) (500g) (4-y)$$

$$= 10 \cdot \frac{1}{2} y \cdot \Delta y \cdot 5000 (4-y)$$

$$= 25000 (4y - y^2) \cdot \Delta y$$

$$\text{Total work } W = \int_0^3 25000 (4y - y^2) dy$$

$$= 25000 \left(2y^2 - \frac{y^3}{3} \right) \Big|_0^3$$

$$= 25000 (18 - 9) = 25000 (9)$$

$$= 225000 \text{ J.}$$

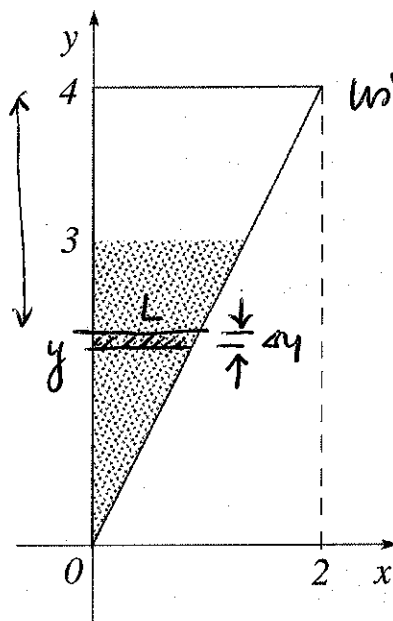

using similar triangles:

$$\frac{L}{2} = \frac{y}{4}$$

$$L = \frac{1}{2} y$$

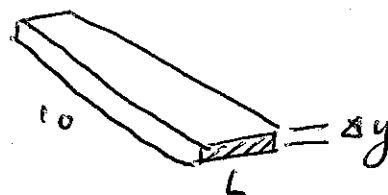
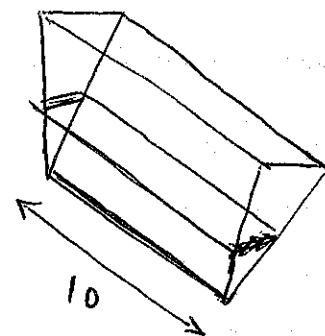

$$\begin{array}{r} 180 \\ 45 \\ \hline 225 \end{array}$$

12. (12 pts.)

Part A. It is observed that a radioactive substance starting with 5 grams reduces to 4 grams after 10 hours in a laboratory. If $y(t)$ is the amount of the substance in gram after t hours, find a formula for $y(t)$. You should explain how you arrive at your answer.

$$y(t) = Ce^{kt} \quad (\leftarrow \text{exponential decay}).$$

$$y(0) = 5 ; \quad y(10) = 4.$$

$$5 = C \Rightarrow y(t) = 5e^{kt}$$

$$y(10) = 4 = 5e^{k(10)} \Rightarrow e^{10k} = \frac{4}{5}$$

$$10k = \ln\left(\frac{4}{5}\right) = \ln(0.8) \Rightarrow k = \frac{1}{10} \ln\left(\frac{4}{5}\right)$$

$$y(t) = 5e^{\frac{t}{10} \ln\left(\frac{4}{5}\right)} \text{ i.e. } 5 \cdot \left(\frac{4}{5}\right)^{t/10} \text{ grams.}$$

Part B. [Unrelated to Part A] Find the area between the graphs $y = 1$ and $y = e^x$ for $-1 \leq x \leq 1$.

$$\int_{-1}^0 (1 - e^x) dx = (x - e^x) \Big|_{-1}^0$$

$$= (0 - e^0) - (-1 - e^{-1}) = 1 + e^{-1}$$

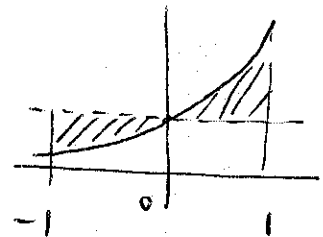

$$\int_0^1 (e^x - 1) dx = (e^x - x) \Big|_0^1$$

$$= e - 1 - (e^0 - 0) = e - 1 - 1 = e - 2$$

$$\boxed{e^x = 1}$$

$$\Rightarrow x = 0$$

$$\text{Total area} = e^{-1} + e - 2$$

13.(12 pts.) Part A. Find the exact volume of the solid generated by revolving the region bounded by the graphs $y = \sqrt{x}$, $y = 0$, and $x = 2$ about the following axes:

(i) x -axis.

$$\Delta V = \pi R^2 \cdot \Delta x = \pi (\sqrt{x})^2 \Delta x = \pi x \Delta x$$

$$V = \int_0^2 \pi x dx = \left[\frac{\pi x^2}{2} \right]_0^2$$

$$= \frac{\pi (2)^2}{2} - 0 = 2\pi$$

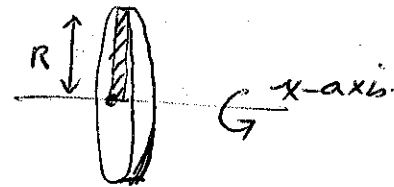
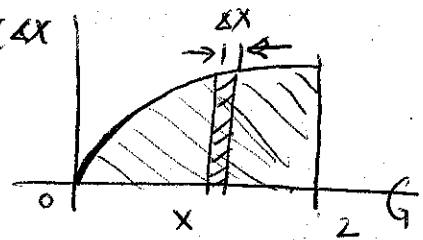

(ii) $x = -1$.

$$\Delta V = 2\pi R h \cdot \Delta x = 2\pi (x+1)\sqrt{x} \cdot \Delta x$$

$$= 2\pi (x^{3/2} + x^{1/2}) \Delta x$$

$$V = \int_0^2 2\pi (x^{3/2} + x^{1/2}) dx$$

$$= 2\pi \left[\frac{2x^{5/2}}{5} + \frac{2}{3}x^{3/2} \right]_0^2$$

$$= 2\pi \left[\frac{2(2)^{5/2}}{5} + \frac{2}{3}(2)^{3/2} \right] = 2\pi \left[\frac{8\sqrt{2}}{5} + \frac{4\sqrt{2}}{3} \right] = \frac{88\sqrt{2}\pi}{15}$$

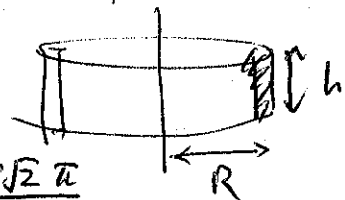
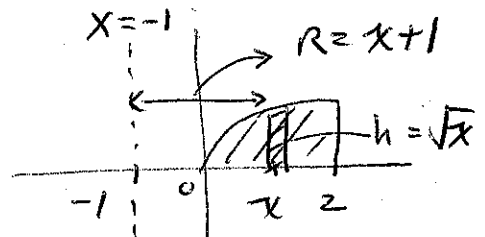

Part B. [Unrelated to Part A] Consider the solid with base the region bounded by the graphs $y = \sqrt{x}$, $y = 0$, and $x = 2$. If the cross-section of the solid perpendicular to the x -axis are rectangles of height x^2 , find the exact volume of the solid.

$$\Delta V = \sqrt{x} \cdot x^2 \cdot \Delta x = x^{5/2} \cdot \Delta x$$

$$V = \int_0^2 x^{5/2} dx = \left[\frac{2}{7} x^{7/2} \right]_0^2$$

$$= \frac{2}{7} (2)^{7/2} = \frac{16\sqrt{2}}{7}$$

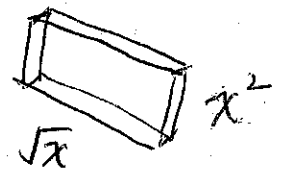

$$\frac{24+20}{15} = \frac{44}{15}$$

Name: _____

Class Time: _____

14.(12 pts.)

Part A. The population density of monkeys measured from the center of a nature reserve is given by the radial function

$$\rho(r) = \frac{1}{(1+r^2)^2},$$

where r is the distance from the center of the reserve measured in kilometers, and ρ is in thousands per km^2 . Find the the number of monkeys (in thousand) within a 2 km radius from the center of the reserve.

$$\Delta P = (\text{Area}) (\text{Density}) = 2\pi r \cdot \Delta r \cdot \rho(r)$$

$$= \frac{2\pi r}{(1+r^2)^2} \Delta r$$

$$u = 1+r^2$$

$$du = 2r dr$$

$$P = \int_0^2 \frac{2\pi r}{(1+r^2)^2} dr$$

$$= \int_1^5 \frac{\pi}{u^2} du = \left[-\frac{\pi}{u} \right]_1^5$$

$$= -\frac{\pi}{5} + \frac{\pi}{1} = \boxed{\frac{4\pi}{5}}$$

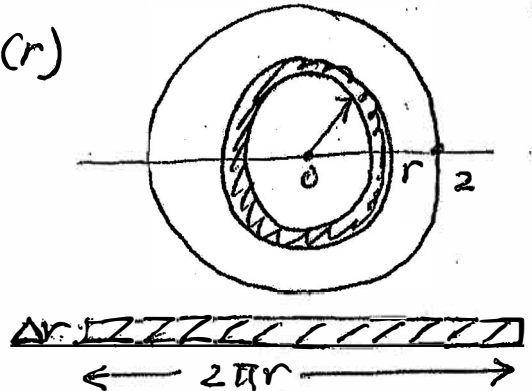

Part B. [Unrelated to Part A] A 20 m rope hangs from the top of a 50 m platform as shown below. Assuming that the rope is uniform and with mass 40 kg, find the work required to lift the upper quarter portion of the rope to the top of the platform.

You may take the acceleration due to gravity g as 10m/s^2 .

See Next Page.

Q14B.

mass density of rope. = $\frac{40}{20} = 2 \text{ kg/m}$

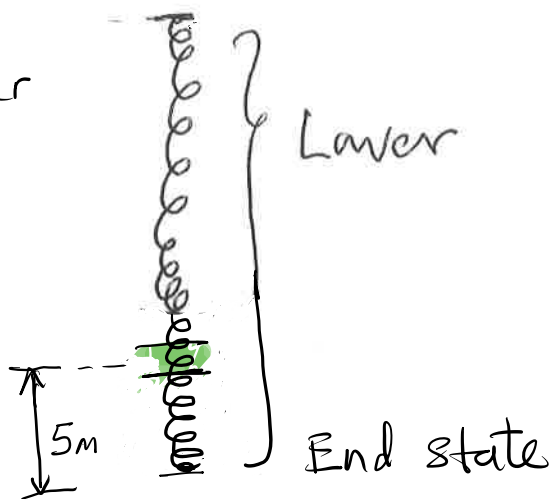
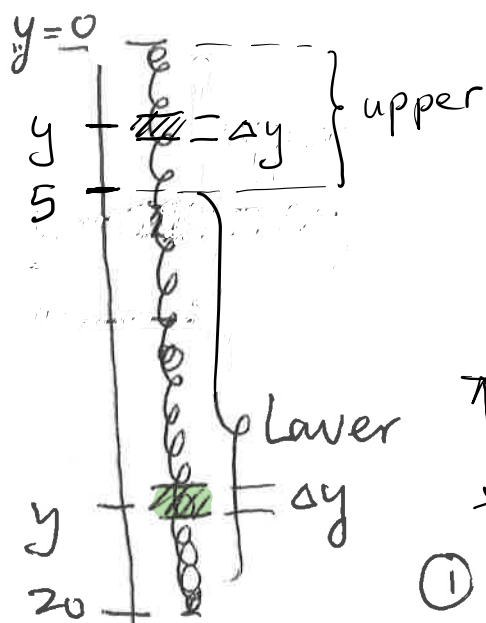

Beginning state

① Work done to lift upper portion ($0 \leq y \leq 5$)

Work done to lift a segment at level y

$$\Delta W_{\text{upper}} \approx \underbrace{F}_{\text{weight of seg}} \times \underbrace{\frac{S}{y}}_{\text{length of seg}} = (2g \cdot \Delta y) \cdot y = 2gy \Delta y$$

$$W_{\text{upper}} = \int_0^5 2gy dy = [2g \cdot \frac{1}{2} y^2]_0^5 = g(5)^2 = 25g \text{ J}$$

② Work done to lift lower portion ($5 \leq y \leq 20$)

Work done to lift a segment at level y .

$$\Delta W_{\text{lower}} \approx \underbrace{F}_{(2g \cdot \Delta y)} \times \frac{S}{5} = 10g \Delta y$$

$$W_{\text{lower}} = \int_5^{20} 10g dy = 10g y \Big|_5^{20} = 10g (20 - 5) = 150g \text{ J}$$

$$\begin{aligned} \text{Work done} &= W_{\text{upper}} + W_{\text{lower}} = 25g + 150g \\ &= 175g = 1750 \text{ J} \end{aligned}$$

Math 10360: Calculus B
Exam I
September 22, 2035

Name: _____

Class Time: _____

- The Honor Code is in effect for this examination. All work is to be your own.
- No calculators.
- The exam lasts for one hour and 15 minutes.
- Be sure that your name is on every page in case pages become detached.
- Be sure that you have all 10 pages of the test.

Sign the pledge. “On my honor, I have neither given nor received unauthorized aid on this Exam”:

Good Luck!

| | | | | | |
|---|----------------------------|----------------------------|----------------------------|----------------------------|----------------------------|
| PLEASE MARK YOUR ANSWERS WITH AN X, not a circle! | | | | | |
| 1. | <input type="checkbox"/> a | <input type="checkbox"/> b | <input type="checkbox"/> c | <input type="checkbox"/> d | <input type="checkbox"/> e |
| 2. | <input type="checkbox"/> a | <input type="checkbox"/> b | <input type="checkbox"/> c | <input type="checkbox"/> d | <input type="checkbox"/> e |
| 3. | <input type="checkbox"/> a | <input type="checkbox"/> b | <input type="checkbox"/> c | <input type="checkbox"/> d | <input type="checkbox"/> e |
| 4. | <input type="checkbox"/> a | <input type="checkbox"/> b | <input type="checkbox"/> c | <input type="checkbox"/> d | <input type="checkbox"/> e |
| 5. | <input type="checkbox"/> a | <input type="checkbox"/> b | <input type="checkbox"/> c | <input type="checkbox"/> d | <input type="checkbox"/> e |
| 6. | <input type="checkbox"/> a | <input type="checkbox"/> b | <input type="checkbox"/> c | <input type="checkbox"/> d | <input type="checkbox"/> e |
| 7. | <input type="checkbox"/> a | <input type="checkbox"/> b | <input type="checkbox"/> c | <input type="checkbox"/> d | <input type="checkbox"/> e |
| 8. | <input type="checkbox"/> a | <input type="checkbox"/> b | <input type="checkbox"/> c | <input type="checkbox"/> d | <input type="checkbox"/> e |
| 9. | <input type="checkbox"/> a | <input type="checkbox"/> b | <input type="checkbox"/> c | <input type="checkbox"/> d | <input type="checkbox"/> e |
| 10. | <input type="checkbox"/> a | <input type="checkbox"/> b | <input type="checkbox"/> c | <input type="checkbox"/> d | <input type="checkbox"/> e |

Please do NOT write in this box.

Multiple Choice _____

11. _____

12. _____

13. _____

14. _____

Total _____

Name: _____

Class Time: _____

Multiple Choice

1.(5 pts.) Treating x as a constant, find the following derivative:

$$\frac{d}{dy} \left(\frac{4x - y}{3x - 2y} \right).$$

(a) $\frac{1}{2}$

(b) $\frac{5x}{(3x - 2y)^2}$

(c) $\frac{4 - y}{3 - 2y}$

(d) $-\frac{5y}{(3x - 2y)^2}$

(e) $\frac{4x - 1}{3x - 2}$

2.(5 pts.) The size $P(t)$ of a population of bacteria in thousands at time t in hours grows according to the model

$$P'(t) = 3P(t).$$

If the initial population is 2 thousand, find the size of the population when $t = 5$.

(a) 6 thousand.

(b) $2 + e^{15}$ thousand.

(c) $3 + e^{10}$ thousand

(d) $2e^{15}$ thousand.

(e) $3e^{10}$ thousand.

Name: _____

Class Time: _____

3.(5 pts.) Which of the values below gives the volume of the solid obtained when the finite region between $y = x^2$, $y = 0$, and $x = 1$ is revolved about the x -axis.

- (a) $\frac{\pi}{5}$
- (b) $\frac{2\pi}{3}$
- (c) π
- (d) $\frac{\pi}{2}$
- (e) $\frac{\pi}{3}$

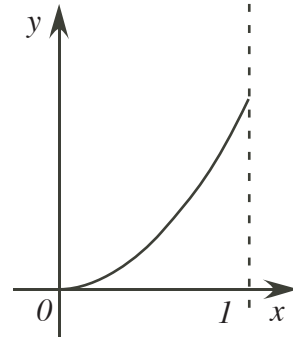

4.(5 pts.) Which of the following expressions is the result of applying the substitution with $u = (2 \ln x + 3)$ to evaluate the integral $\int_1^e \frac{1}{x(2 \ln x + 3)} dx$?

- (a) $\int_1^e \frac{1}{2u} du$
- (b) $\int_3^5 \frac{1}{u} du$
- (c) $\int_1^e \frac{1}{ue^{(u-3)/2}} du$
- (d) $\int_3^5 \frac{1}{2u} du$
- (e) None of these.

Name: _____

Class Time: _____

5.(5 pts.) Find the equation of the tangent line to the graph of the function

$$f(x) = 2 \ln x - 3x^2$$

at $x = 1$.

(a) $y + 3 = -4(x - 1)$

(b) $y - 3 = \left(\frac{2}{x} - 6x\right)(x + 1)$

(c) $y - 1 = -4(x + 3)$

(d) $y + 3 = \left(\frac{2}{x} - 6x\right)(x - 1)$

(e) $y - 3 = -4(x + 1)$

6.(5 pts.) The graph of the function $f(x)$ passes through the point $\left(\frac{1}{2}, \frac{\pi}{8} + \frac{1}{2}\right)$ and its slope is given by $\frac{1}{1 + 4x^2}$.

(a) $\arctan(2x) + 1$

(b) $\arctan(2x)$

(c) $\frac{1}{2} \arctan(2x) + 1$

(d) $\frac{1}{2} \arctan(2x) + \frac{1}{2}$

(e) $\frac{1}{2} \arctan(2x) - \frac{1}{2}$

Name: _____

Class Time: _____

7.(5 pts.) Find the derivative of the function

$$y = e^{2x} \sin^{-1}(x).$$

(a) $\frac{2e^{2x}}{\sqrt{1-x^2}}$

(b) $\frac{e^{2x}}{1+x^2} + e^{2x} \sin^{-1}(x)$

(c) $e^{2x} \cos^{-1}(x) + 2e^{2x} \sin^{-1}(x)$

(d) $\frac{2e^{2x}}{\sqrt{1-x^2}} + e^{2x} \sin^{-1}(x)$

(e) $\frac{e^{2x}}{\sqrt{1-x^2}} + 2e^{2x} \sin^{-1}(x)$

8.(5 pts.) If $\ln x = -1$ and $\ln y = 4$, find the exact value of $\ln(e^4 x \sqrt{y})$.

(a) -7

(b) -8

(c) -5

(d) 5

(e) 7

Name: _____

Class Time: _____

9.(5 pts.) A 10-m chain with mass 30 kg hangs by one end from the top of a tall building (See diagram below), find the work required to lift the **entire** chain to the top of the building.

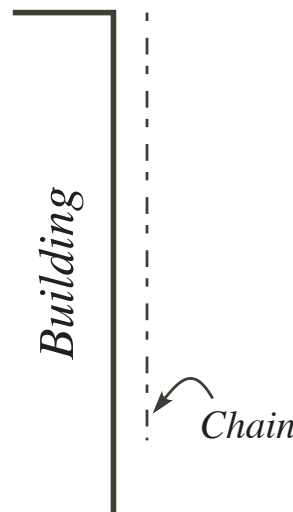

- (a) 3000 J.
- (b) 500 J.
- (c) 1000 J.
- (d) 750 J.
- (e) 1500 J.

10.(5 pts.) The amount $P(t)$ of a radioactive substance decays according to the equation:

$$\frac{dP}{dt} = k \cdot P$$

If 80% of the radioactive sample remains after 2 hours, what is the value of k ?

- (a) $k = \frac{\ln(0.8)}{\ln(0.5)}$ hours.
- (b) $k = 2[\ln(0.5) - \ln(0.8)]$ hours.
- (c) $k = \frac{\ln(0.8)}{2}$ hours.
- (d) $k = \frac{2 \ln(0.5)}{\ln(0.8)}$ hours.
- (e) $k = 2 \ln\left(\frac{5}{8}\right)$ hours.

Name: _____

Class Time: _____

Partial Credit

You must show your work on the partial credit problems to receive credit!

11.(12 pts.)

[Part A]. Consider the solid whose base is bounded by the lines $y = \frac{x}{2}$, $y = 2$, and $x = 0$. Find the volume of the solid if the cross-sections perpendicular to the y -axis are squares.

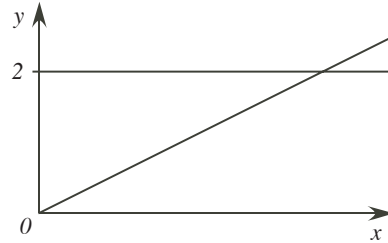

[Part B]. Calculate the population within the 2-mile radius of a city center if the radial population density is $\rho(r) = \frac{1}{4 + r^2}$ thousands per square mile. Simplify your answer as far as possible

Name: _____

Class Time: _____

12.(12 pts.)

[Part A]. Find the values of x for which the following two curves intersect:

$$y = x^2 - 5x + 1 \quad \text{and} \quad y = -2x + 5.$$

Show clearly your set up and computations.

[Part B]. Find the area bounded between the curves $y = x^2$ and $y = 8 - x^2$ for $0 \leq x \leq 2$. Show clearly your set up and computations.

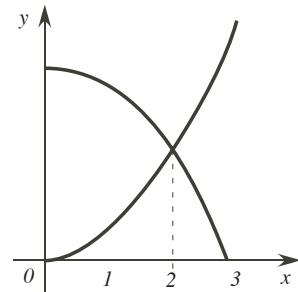

Name: _____

Class Time: _____

13.(12 pts.)

[Part A]. Using **shell method**, find the volume of the solid obtained when the region $y = x^2 + 1$, $y = 2$, and $x = 0$ is revolved about the y -axis.

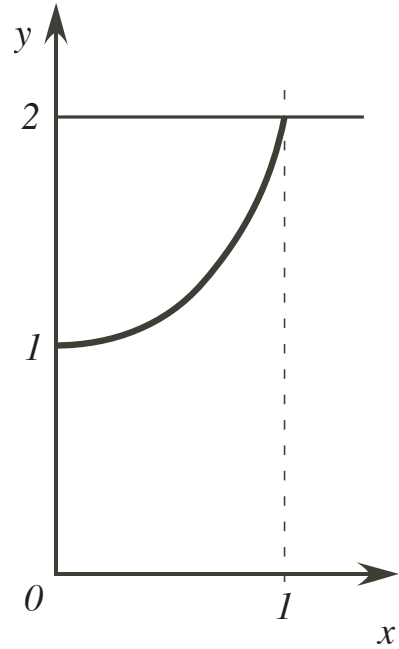

[Part B]. A 10-m chain with mass 30 kg hangs by one end from the top of a tall building (See diagram below), find the work required to lift the **top** 2-m chain to the top of the building.

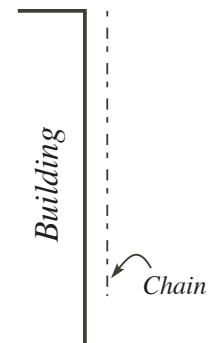

Name: _____

Class Time: _____

14.(12 pts.)

[Part A]. Perform the following integral:

$$\int_1^e \frac{\ln(x)}{x} dx \stackrel{?}{=}$$

[Part B]. Evaluate the integral:

$$\int_0^{\pi/4} \tan x \, dx \stackrel{?}{=}$$

Math 10360: Calculus B
Exam I
September 22, 2035

Name: _____
Class Time: ANSWERS

- The Honor Code is in effect for this examination. All work is to be your own.
- No calculators.
- The exam lasts for one hour and 15 minutes.
- Be sure that your name is on every page in case pages become detached.
- Be sure that you have all 10 pages of the test.

Sign the pledge. “On my honor, I have neither given nor received unauthorized aid on this Exam”:

Good Luck!

| | | | | | |
|---|-------------------------------------|-------------------------------------|-------------------------------------|-------------------------------------|-------------------------------------|
| PLEASE MARK YOUR ANSWERS WITH AN X, not a circle! | | | | | |
| 1. | <input type="checkbox"/> a | <input checked="" type="checkbox"/> | <input type="checkbox"/> c | <input type="checkbox"/> d | <input type="checkbox"/> e |
| 2. | <input type="checkbox"/> a | <input type="checkbox"/> b | <input type="checkbox"/> c | <input checked="" type="checkbox"/> | <input type="checkbox"/> e |
| 3. | <input checked="" type="checkbox"/> | <input type="checkbox"/> b | <input type="checkbox"/> c | <input type="checkbox"/> d | <input type="checkbox"/> e |
| 4. | <input type="checkbox"/> a | <input type="checkbox"/> b | <input type="checkbox"/> c | <input checked="" type="checkbox"/> | <input type="checkbox"/> e |
| 5. | <input checked="" type="checkbox"/> | <input type="checkbox"/> b | <input type="checkbox"/> c | <input type="checkbox"/> d | <input type="checkbox"/> e |
| 6. | <input type="checkbox"/> a | <input type="checkbox"/> b | <input type="checkbox"/> c | <input checked="" type="checkbox"/> | <input type="checkbox"/> e |
| 7. | <input type="checkbox"/> a | <input type="checkbox"/> b | <input type="checkbox"/> c | <input type="checkbox"/> d | <input checked="" type="checkbox"/> |
| 8. | <input type="checkbox"/> a | <input type="checkbox"/> b | <input type="checkbox"/> c | <input checked="" type="checkbox"/> | <input type="checkbox"/> e |
| 9. | <input type="checkbox"/> a | <input type="checkbox"/> b | <input type="checkbox"/> c | <input type="checkbox"/> d | <input checked="" type="checkbox"/> |
| 10. | <input type="checkbox"/> a | <input type="checkbox"/> b | <input checked="" type="checkbox"/> | <input type="checkbox"/> d | <input type="checkbox"/> e |

| | |
|---|-------|
| Please do NOT write in this box. | |
| Multiple Choice | _____ |
| 11. | _____ |
| 12. | _____ |
| 13. | _____ |
| 14. | _____ |
| Total | _____ |

Name: _____

Class Time: _____

Partial Credit

You must show your work on the partial credit problems to receive credit!

11. (12 pts.)

[Part A]. Consider the solid whose base is bounded by the lines $y = \frac{x}{2}$, $y = 2$, and $x = 0$. Find the volume of the solid if the cross-sections perpendicular to the y -axis are squares.

$$\Delta V = L^2 \cdot \Delta y = (2y)^2 \Delta y = 4y^2 \Delta y$$

$$V = \int_0^2 4y^2 dy = \frac{4y^3}{3} \Big|_0^2 =$$

$$= \frac{4(8)}{3} = \frac{32}{3}$$

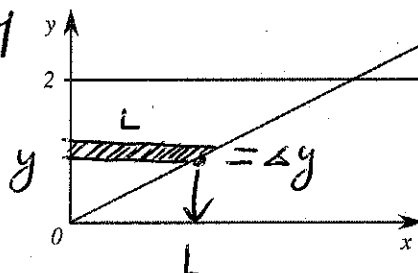

$$\begin{aligned} y &= L/2 \\ L &= 2y \end{aligned}$$

[Part B]. Calculate the population within the 2-mile radius of a city center if the radial population density is $\rho(r) = \frac{1}{4+r^2}$ thousands per square mile. Simplify your answer as far as possible

$$\Delta P = (\text{Area}) \cdot (\text{density}) = 2\pi r \Delta r \cdot \frac{1}{4+r^2}$$

$$= \frac{2\pi r}{4+r^2} \Delta r$$

$$P = \int_0^2 \frac{2\pi r}{4+r^2} dr$$

$$\begin{aligned} u &= 4+r^2 \\ du &= 2r dr \end{aligned}$$

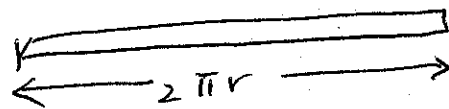
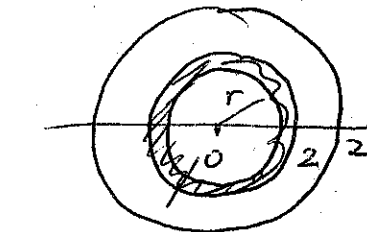

$$= \int_4^8 \frac{\pi}{u} du = \pi \ln|u| \Big|_4^8$$

$$= \pi \ln 8 - \pi \ln 4$$

$$= \pi \ln \left(\frac{8}{4} \right) = \underline{\underline{\pi \ln 2}}$$

Name: _____

Class Time: _____

12. (12 pts.)

[Part A]. Find the values of x for which the following two curves intersect:

$$y = x^2 - 5x + 1 \quad \text{and} \quad y = -2x + 5.$$

Show clearly your set up and computations.

$$x^2 - 5x + 1 = -2x + 5 \Rightarrow x^2 - 3x - 4 = 0$$

$$\Rightarrow (x - 4)(x + 1) = 0 \Rightarrow x = 4, -1.$$

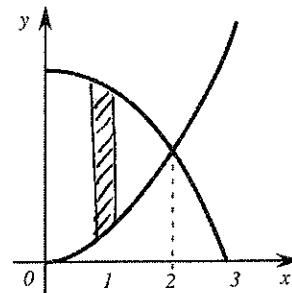
[Part B]. Find the area bounded between the curves $y = x^2$ and $y = 8 - x^2$ for $0 \leq x \leq 2$. Show clearly your set up and computations.

$$\int_0^2 [(8 - x^2) - x^2] dx$$

$$= \int_0^2 (8 - 2x^2) dx$$

$$= \left[8x - \frac{2}{3}x^3 \right]_0^2 = 16 - \frac{2}{3}(8) - 0$$

$$= \frac{2}{3}(16) = \boxed{\frac{32}{3}}$$

Name: _____

Class Time: _____

13. (12 pts.)

[Part A]. Using shell method, find the volume of the solid obtained when the region $y = x^2 + 1$, $y = 2$, and $x = 0$ is revolved about the y -axis.

$$\Delta V = 2\pi R h \cdot \Delta x = 2\pi x(1-x^2)\Delta x$$

$$V = \int_0^1 2\pi(x-x^3) dx$$

$$= 2\pi \left[\frac{x^2}{2} - \frac{x^4}{4} \right]_0^1$$

$$= 2\pi \left[\frac{1}{2} - \frac{1}{4} \right] = \boxed{\frac{\pi}{2}}$$

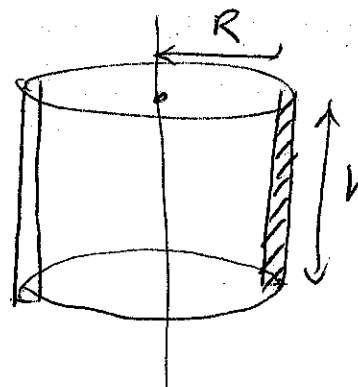
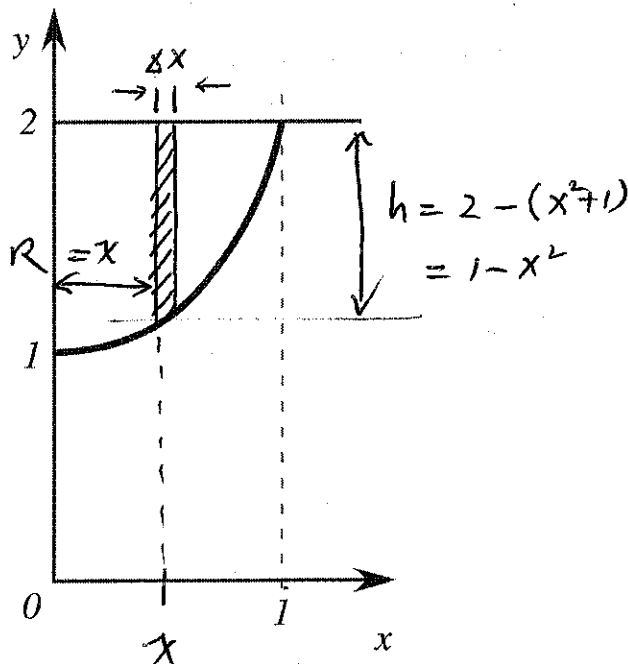

[Part B]. A 10-m chain with mass 30 kg hangs by one end from the top of a tall building (See diagram below), find the work required to lift the **entire** chain to the top of the building.

$$\Delta W = (\text{Force})(\text{Displ.}) = 3g \Delta y \cdot y$$

$$= 30y \Delta y$$

$$W = \int_0^{10} 30y dy = 15y^2 \Big|_0^{10}$$

$$= 1500 \text{ J}$$

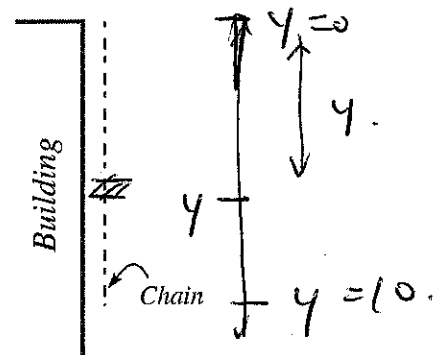

[Part B] A 10 m chain with mass 30 kg hangs by one end from the top of a tall building (see diag. below). Find the work required to lift the top 2 m of the chain to the top of the building.

① Work done to lift upper portion

work done to lift a segment at level y to the top ($0 \leq y \leq 2$)

$$\Delta W_1 \approx \underbrace{\text{Force}}_{\text{weight of segment}} \times \underbrace{\text{Displacement}}_y$$

$$= (3g \cdot \Delta y)(y) = 3gy \Delta y$$

$$W_1 = \int_0^2 3gy dy = \frac{3gy^2}{2} \Big|_0^2 = \underline{6g} \text{ J.}$$

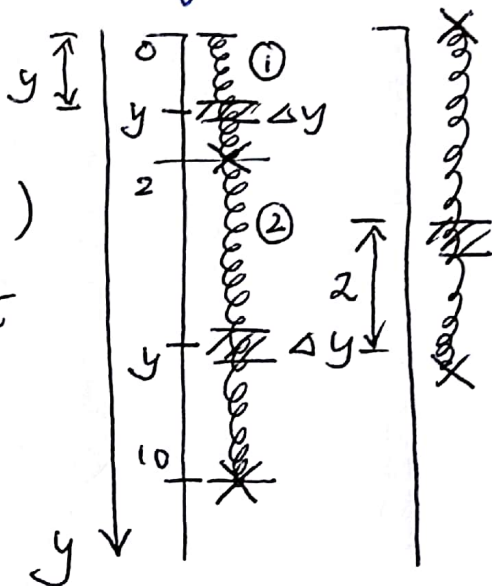

② Work done to lift the lower portion ($2 \leq y \leq 10$)
work done to lift a segment at level y to its final location.

$$\Delta W_2 \approx \underbrace{\text{Force}}_{3g \cdot \Delta y} \times \underbrace{\text{Displacement}}_2$$

2 ← the lower portion translates up by 2 m.

$$= 6g \Delta y$$

$$W_2 = \int_2^{10} 6g dy = 6gy \Big|_2^{10} = 6g(8) = 48g \text{ J}$$

$$\begin{aligned} \text{Total work, } W &= W_1 + W_2 = 6g + 48g \\ &= 54g = 540 \text{ J if } g = 10 \text{ m/s}^2. \end{aligned}$$

Name: _____

Class Time: _____

14. (12 pts.)

[Part A]. Perform the following integral:

$$\int_1^e \frac{\ln(x)}{x} dx \stackrel{?}{=} \int_1^e \ln(x) \cdot \frac{1}{x} dx$$

$$= \int_0^1 u du = \left. \frac{u^2}{2} \right|_0^1$$

$$= \frac{1}{2}$$

$$u = \ln(x)$$

$$du = \frac{1}{x} dx.$$

[Part B]. Evaluate the integral:

$$\int_0^{\pi/4} \tan x dx \stackrel{?}{=} \int_0^{\frac{\pi}{4}} \frac{\sin x}{\cos x} dx$$

$$= \int_1^{\frac{1}{\sqrt{2}}} \frac{1}{u} (-du)$$

$$= \left[-\ln|u| \right]_1^{\frac{1}{\sqrt{2}}} = -\ln \frac{1}{\sqrt{2}} - \underbrace{\left(-\ln 1 \right)}_0$$

$$= -\ln(\sqrt{2})^{-1} = \ln \sqrt{2}$$

$$\text{or } \frac{1}{2} \ln 2$$

$$u = \cos x.$$

$$du = -\sin x dx$$

$$\sin x dx = -du$$