

SCANNING THE ISSUE/TECHNOLOGY

Special Issue on Hybrid Systems: Theory and Applications

A Brief Introduction to the Theory and Applications of Hybrid Systems

Abstract

The hybrid systems of interest contain two distinct types of components, subsystems with continuous dynamics and subsystems with discrete dynamics that interact with each other. Such hybrid systems arise in varied contexts in manufacturing, communication networks, auto-pilot design, automotive engine control, computer synchronization, traffic control, and chemical processes, among others. Hybrid systems have a central role in embedded control systems that interact with the physical world. They also arise from the hierarchical organization of complex systems, and from the interaction of discrete planning algorithms and continuous control algorithms in autonomous, intelligent systems. In this article, a brief introduction to the theory and applications of hybrid systems is presented and an outline of the papers in this special issue is given.

Keywords Hybrid Systems, Hybrid Control, Continuous and Discrete Event Dynamical Systems, Embedded Systems

INTRODUCTION

Hybrid Systems

Hybrid means, in general, heterogeneous in nature or composition and the term hybrid systems means systems with behavior defined by entities or processes of distinct characteristics. Here the term hybrid refers to combinations or compositions of continuous and discrete parts and a hybrid dynamical system is understood to mean a dynamical system where the behavior of interest is determined by interacting continuous and discrete dynamics. Hybrid dynamical systems generate variables or signals, that are mixed signals consisting of combinations of continuous or discrete value or time signals, and through them interaction with other systems and the environment occurs. More specifically, some of these signals take values from a continuous set (e.g. the set of real numbers) and others take values from a discrete, typically finite set (e.g. the set of symbols $\{a, b, c\}$). Furthermore, these continuous or discrete-valued signals depend on independent variables such as time, which may also be continuous or discrete. Another distinction that could be made is that some of the signals could be time-driven while others could be event-driven in an asynchronous manner. The investigation of hybrid systems is creating a new and fascinating discipline bridging control engineering, mathematics and computer science.

There has been significant research activity in the area of hybrid systems in the past decade involving researchers from several areas. See for example, the books [1-11], the journal special issues [12-16] and

the tutorial and survey papers [17-18], in addition to the papers in this special issue of the Proceedings of the IEEE. Some of the early references in hybrid systems that have helped define and shape the main approaches in the current research of hybrid systems can be found in these references; many of these are of course references of the papers included in this special issue.

Applications and Background

When the continuous and discrete dynamics coexist and interact with each other it is important to develop models that accurately describe the dynamic behavior of such hybrid systems. Only in this way it may be possible to develop designs that fully take into consideration the relations and interaction of the continuous and discrete parts of the system. Many times it is not only desirable but also natural to use hybrid models to describe the dynamic behavior of systems. In a manufacturing process for example, parts may be processed in a particular machine but only the arrival of a part triggers the process; that is, the manufacturing process is composed of the event-driven dynamics of the parts moving among different machines and the time-driven dynamics of the processes within particular machines. Frequently in hybrid systems in the past, the event-driven dynamics were studied separately from the time-driven dynamics, the former via automata or Petri net models (also via PLC, logic expressions etc.) and the latter via differential or difference equations. To fully understand the system's behavior and meet high performance specifications one needs to model all dynamics together with their interactions, and this is most important when there are strong interactions among the parts of the system. Only then problems such as optimization of the whole manufacturing process may be addressed in a more meaningful manner. There are of course cases where the time-driven and event-driven dynamics are not tightly coupled or the demands on the system performance are not difficult to meet and in those cases considering simpler separate models for the distinct phenomena may be adequate. However hybrid models must be used when there is significant interaction between the continuous and discrete parts and high performance specifications are to be met by the system.

Hybrid models may also be used to significant advantage for example in automotive engine control, where there is need of control algorithms with guaranteed properties, implemented via embedded controllers, that can substantially reduce emissions and gas consumption while maintaining the performance of the car. Note that an accurate model of a four-stroke gasoline engine has a natural hybrid representation, because from the engine control point of view, on one hand the power train and air dynamics are continuous-time processes, while on the other hand, the pistons have four modes of operation that correspond to the stroke they are in and so their behavior is represented as a discrete event process represented say via a finite state machine model. These processes interact tightly, as the timing of the transitions between two phases of the pistons is determined by the continuous motion of the power train, which, in turn depends on the torque produced by each piston. Note that in the past the practice has been to convert the discrete part of the engine behavior into a more familiar and easier to handle continuous model, where only the average values of the appropriate

physical quantities are modeled. Using hybrid models one may represent time and event-based behaviors more accurately so to meet challenging design requirements in the design of control systems for problems such as cut-off control and idle speed control of the engine. For similar reasons, that is tight interaction of continuous and discrete dynamics and demands for high performance for the system, hybrid models are important in chemical processes, robotic manufacturing systems, transportation systems, air traffic control systems among many other applications.

There are other ways hybrid systems may arise. Hybrid systems arise from the interaction of discrete planning algorithms and continuous processes, and as such, they provide the basic framework and methodology for the analysis and synthesis of autonomous and intelligent systems. In fact, the study of hybrid systems is essential in designing sequential supervisory controllers for continuous systems, and it is central in designing intelligent control systems with a high degree of autonomy (see for example [19,20]). Another important way in which hybrid systems arise is from the hierarchical organization of complex systems. In these systems, a hierarchical organization helps manage complexity and higher levels in the hierarchy require less detailed models (discrete abstractions) of the functioning of the lower levels, necessitating the interaction of discrete and continuous components. Examples of such systems include flexible manufacturing and chemical process control systems, interconnected power systems, intelligent highway systems, air traffic management systems, computer and communication networks.

In the control systems area, a very well known instance of a hybrid system is a sampled-data or digital control system. There, a system described by differential equations, which involve continuous-valued variables that depend on continuous time, is controlled by a discrete-time controller described by difference equations, which involve continuous-valued variables that depend on discrete time (see for example [21]). If one also considers quantization of the continuous-valued variables or signals, then the hybrid systems contains not only continuous-valued variables that are driven by continuous and discrete times, but also discrete-valued signals as well. Another example of a hybrid control system is a switching system where the dynamic behavior of interest can be adequately described by a finite number of dynamical models, that are typically sets of differential or difference equations, together with a set of rules for switching among these models. These switching rules are described by logic expressions or a discrete event system with a finite automaton or a Petri net representation.

A familiar simple example of a practical hybrid control system is the heating and cooling system of a typical home. The furnace and air conditioner, along with the heat flow characteristics of the home, form a continuous-time system, which is to be controlled. The thermostat is a simple asynchronous discrete-event system, which basically handles the symbols $\{too\ hot,\ too\ cold\}$ and $\{normal\}$. The temperature of the room is translated into these representations in the thermostat and the thermostat's response is translated back to electrical currents, which control the furnace, air conditioner, blower, etc.

There are several reasons for using hybrid models to represent dynamic behavior of interest in addition to

the ones already mentioned. Reducing complexity was and still is an important reason for dealing with hybrid systems. This is accomplished in hybrid systems by incorporating models of dynamic processes at different levels of abstraction; for example the thermostat in the above example sees a very simple, but adequate for the task in hand, model of the complex heat flow dynamics. For another example, in order to avoid dealing directly with a set of nonlinear equations one may choose to work with sets of simpler equations (e.g. linear), and switch among these simpler models. This is a rather common approach in modeling physical phenomena. In control, switching among simpler dynamical systems has been used successfully in practice for many decades. Recent efforts in hybrid systems research along these lines typically concentrate on the analysis of the dynamic behaviors and aim to design controllers with guaranteed stability and performance.

Hybrid systems have been important for a long time. The recent interest and activity in hybrid systems has been motivated in part by the development of research results in the control of discrete event systems (DES) that occurred in the 80's and of adaptive control in the 70's and 80's and of the renewed interest in optimal control formulations in sampled-data systems and digital control (see for example [22]). In parallel developments, there has been growing interest in hybrid systems among computer scientists and logicians with emphasis on verification of design of computer software. Whenever the behavior of a computer program depends on values of continuous variables within that program (e.g. continuous time clocks), one needs hybrid system methodologies to guarantee correctness of the program. In fact the verification of such digital computer programs has been one of the main goals of several serious research efforts in hybrid systems literature. Note that efficient verification methodologies are essential for complex hybrid systems to be useful in applications. The advent of digital machines has made hybrid systems very common indeed. Whenever a digital device interacts with the continuous world, the behavior involves hybrid phenomena that need to be analyzed and understood.

Hybrid systems represent a highly challenging area of research that encompasses a variety of challenging problems that may be approached at varied levels of detail and sophistication. Modeling of hybrid systems is very important, as modeling is in every scientific and engineering discipline. There are different types of models used, from detailed models that may include equations and look up tables that are excellent for simulation but not easily amenable to analysis, to models that are also good for analysis but not easily amenable to synthesis, models for control, models for verification and so on. Below a brief introduction to modeling signals and systems is presented.

MODELING SIGNALS AND SYSTEMS

Modeling Signals

Continuous and discrete-time signals, where a signal $f(t)$ takes on a value from the set of real numbers for each value of the independent variable or time t , are certainly familiar to all. In continuous variables or

analog signals, both the values of $f(t)$ and the time t are real numbers; that is $f(t)$ is defined for any real t in some interval and it may take on any real value. Examples include voltages and currents in a *RLC* circuit. Discrete signals are defined only for discrete values of time t and not for any real value t . For example a voltage may be measured every tenth of a second, but not in between. This is the case for example when the value of a signal, that could be representing some temperature or pressure in an engine, is known only from periodic measurements or samples. Such discrete signals are typical in sampling continuous signals in a periodic or non periodic manner. Every electrical engineer has studied continuous and discrete-time signals in the time domain or in transform domain using Fourier, Laplace and z transforms. The relation between a continuous-time signal $f(t)$ and its sampled version $\{f(t_k)\}$ has been of great interest in several fields such as signal processing and numerical analysis. For example the celebrated Sampling Theorem prescribes the sampling rate so to be able to reconstruct the original (frequency band limited) signal $f(t)$ (see for example [23]). Now the value of a discrete-time signal may be obtained or stored using a digital device and because of the finite word length it is only approximated with accuracy depending primarily on the finite word length of the device. That is, a discrete-time signal becomes a digital one by quantization and in this case $f(t)$ takes on values from a discrete set. Such quantized, discrete-valued signals typically are not studied together with the continuous-valued ones primarily because of the mathematical difficulties. Instead, some probabilistic analysis of the quantization effects is frequently performed separately to validate the design. It should be noted also that today's digital devices tend to use longer word lengths and so the use of continuous-valued signals instead of discrete-valued in the analysis is adequate for many practical purposes.

Is the world after all analog, is it digital or is it both? This is certainly a rather challenging question to answer! But some thoughts are perhaps of some use to the reader. Certainly there are many examples of discrete decision making, cases where phenomena are inherently discrete and cases where physical quantities are sampled and represented via discrete values. Analog signals contain a continuum of real values, such a voltage $v(t)$. Does an analog signal really exist or is it just a convenient way to represent signals? Recall that real numbers are such that between any two there is always a third real number. Does it make sense then to talk about values of voltages or distances represented perhaps by an infinite number of decimals in view of the fact that our measurements provide us only with a finite number of decimal digits? One could say of course that real numbers do not really exist in nature, but they represent an idealization that has helped us understand phenomena ranging from the motion of planets to the behavior of atoms. This may very well be true, however real numbers have retained their usefulness on scales smaller than one hundredth of the classical diameter of subatomic particles (electron, proton) and are possibly valid down to the quantum gravity scale, twenty orders of magnitude smaller than such a particle. It appears then that real numbers and continuous variables and signals are here to stay.

Modeling Dynamical Systems

The dynamical behavior of systems can be understood by studying their mathematical descriptions. The flight path of an airplane subject to certain engine thrust, rudder and elevator angles and under particular wind conditions, or the behavior of an automobile on cruise control when climbing a hill of certain elevation, the evolution in time of a production system in manufacturing can be predicted using mathematical descriptions of the behavior of interest. Mathematical relations, that typically involve differential or difference equations or finite automata and Petri nets, are used to describe the behavior of processes and predict their response when certain inputs are applied (see for example [24-26]). Although computer simulation is an excellent tool for verifying predicted behavior and thus for enhancing our understanding of processes, it is certainly not an adequate substitute in analysis or design for generating the information captured in a mathematical model, when of course such a model is available.

Over the centuries, a great deal of progress has been made in developing mathematical descriptions of physical phenomena. In doing so, laws or principles of physics, chemistry, biology, economics, etc., are invoked to derive mathematical expressions (usually equations) which characterize the evolution in time of the variables that are of interest. The availability of such mathematical descriptions enables us to make use of the vast resources offered by the many areas of applied and pure mathematics to conduct qualitative and quantitative studies of the behavior of processes. A given model of a physical process may give rise to several different mathematical descriptions. For example, when applying Kirchhoff's voltage and current laws to a low frequency transistor model, one can derive a set of differential and algebraic equations, or a set consisting only of differential equations, or, a set of integro-differential equations, and so forth. The process of mathematical modeling, from a physical phenomenon to a model to a mathematical description, is essential in science and engineering. To capture phenomena of interest accurately and in tractable mathematical form is a demanding task, as can be imagined, and requires a thorough understanding of the process involved. In most nontrivial cases, this type of modeling process is close to an art form, since a good mathematical description must be detailed enough to accurately describe the phenomena of interest and at the same time simple enough to be amenable to analysis. Depending on the applications on hand, a given mathematical description of a process may be further simplified before it is used in analysis and especially in design procedures. A point which cannot be overemphasized is that mathematical descriptions characterize processes only approximately. Most often, this is the case because the complexity of physical systems defies exact mathematical formulation. In many other cases, however, it is our own choice that a mathematical description of a given process approximates the actual phenomena only by a certain desired degree of accuracy for simplicity. For example, in the description of *RLC* circuits, one could use nonlinear differential equations which take into consideration parasitic effects in the capacitors. Most often however it suffices to use linear ordinary differential equations with constant coefficients to describe the voltage-current relations of such circuits, since typically such a description provides an adequate approximation and since it is much easier to work with linear rather than

nonlinear differential equations.

There are of course many examples of systems that cannot be conveniently described by continuous models and differential equations. Such systems include production lines in manufacturing, computer networks, traffic systems etc. where their evolution in time depends on complex interactions of the timing of various discrete events. Such discrete event dynamical systems are modeled by discrete models, such as finite automata. Since many of these systems are man-made, the models tend to be easier to construct and be more accurate (although they tend to grow very large in the number of states) than in the case of modeling physical systems, however the same modeling considerations as the ones discussed above still apply.

The behavior of a hybrid dynamic system may be described via different models the detail and nature of which depends on what the intended use of the model is. There are hybrid models in the literature, that are more appropriate for simulation than for analysis or design. For some early mathematical models for hybrid systems and a comparison between models, see [27-30]. In this special issue we are primarily interested in models that have been shown to be useful in the analysis of properties and the synthesis of controllers for hybrid systems.

APPROACHES TO THE ANALYSIS AND DESIGN OF HYBRID SYSTEMS

Systems that integrate continuous and discrete dynamics were of interest in the control systems and computer science literature in the past. For instance, in system theory in the 60s researchers were discussing mathematical frameworks so to study systems with continuous and discrete dynamics (see for example [31]). Current approaches to hybrid systems differ with respect to the emphasis on or the complexity of the continuous and discrete dynamics, and on whether they emphasize analysis and synthesis results or analysis only or simulation only. On one end of the spectrum there are approaches to hybrid systems that represent extensions of system theoretic ideas for systems (with continuous-valued variables and continuous time) that are described by ordinary differential equations to include discrete time and variables that exhibit jumps, or extend results to switching systems. Typically these approaches are able to deal with complex continuous dynamics. Their main emphasis has been on the stability of systems with discontinuities. On the other end of the spectrum there are approaches to hybrid systems embedded in computer science models and methods, that represent extensions of verification methodologies from discrete systems to hybrid systems. Typically these approaches are able to deal with discrete dynamics described by finite automata and emphasize analysis results (verification) and simulation methodologies. There are additional methodologies spanning the rest of the spectrum that combine concepts from continuous control systems described by linear and nonlinear differential/difference equations, and from supervisory control of discrete event systems that are described by finite automata and Petri nets to derive, with varying success, analysis and synthesis results. Several

approaches to modeling, analysis and synthesis of hybrid systems are represented in this special issue.

In the area of control systems, powerful methodologies for analysis of properties such as stability and systematic methodologies for the design of controllers have been developed over the years (see for example [32],[24],[25]). Characteristics of the approaches are the fact that control systems are seen as interconnected systems where the system to be controlled is connected to the controller, the fact that the models describe continuous dynamics that depend on continuous or discrete time, and that under clearly stated assumptions, properties such as reachability and stability are guaranteed. Such guarantees are of course important but they become absolutely essential in safety-critical systems such as chemical and nuclear processes, aircraft traffic control etc. In parallel developments to the continuous systems case, that were based on differential equations as well as Fourier and Laplace transforms, developments in sampled-data systems and digital control based on difference equations as well as on Fourier and z -transforms were taking place since the 50s (see for example [21]).

In the 80s systems with discrete dynamics such as manufacturing systems attracted the attention of the control research community, and models such as finite automata were used to describe such discrete event dynamical systems. Important system properties such as controllability and observability (see for example [33],[26]) and stability (see for example [34],[35]) were defined and studied for discrete event systems and methodologies for supervisory control design were developed [33]. In related developments, the relation between inherently discrete planning systems and continuous feedback control systems attracted attention [36],[37]. In addition to finite automata other modeling paradigms such as Petri nets gained the attention of control and automation system researchers in the last decade primarily in Europe (see for example [18]). Petri nets have been used in the supervisory control of discrete event dynamic systems (see for example [38]) as an attractive alternative to methodologies based on finite automata.

There are analogies between certain current approaches to hybrid control and digital control systems methodologies; see Figure 1. Specifically, in digital control one could carry the control design in the continuous time domain, then approximate or emulate the controller by a discrete controller and implement it using an interface consisting of a sampler and a hold device (A/D and D/A respectively). Alternatively, one could obtain first a discrete model of the plant taken together with the interface and then carry the controller design in the discrete domain. In hybrid systems, in a manner analogous to the latter case, one may obtain a discrete event model of the plant together with the interface using automata or Petri nets; the controller is then designed using DES supervisory methodologies; see Figure 2. This is the approach taken in supervisory control approaches to hybrid systems. Approaches analogous to the former also exist (continualization). Optimization methodologies are also used in hybrid control synthesis that include convex optimization and game theoretic approaches.

Another class of approaches that originate in and represent extensions of classical control system analysis methodologies address stability issues in hybrid systems (see for example [39]). These approaches typically

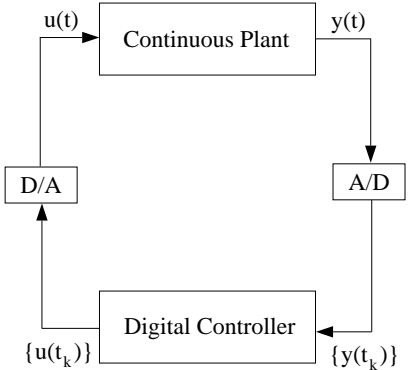

Figure 1: Sampled-data system - Digital control.

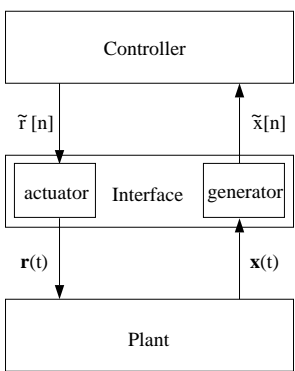

Figure 2: Hybrid system model for supervisory control

consider Lyapunov techniques applied to continuous or discrete-time systems with continuous dynamics that are interconnected via some switching mechanism and provide primarily sufficient conditions which if satisfied then the stability of the system is assured [40]. Hybrid control may offer significant advantages over classical control. There are cases for example where nonlinear systems may be asymptotically stabilizable, but not via smooth feedback control functions. In this case hybrid switching controllers may offer a solution. In addition, even for systems that are smoothly stabilizable hybrid controllers may prove superior to fixed nonlinear controllers by expanding, for example, the domain of attraction and so guaranteeing the system is stable over a wider range of operating conditions.

Discrete dynamics always were of interest in computer science and models such as automata, but also Petri nets to a lesser extent, have been used to represent and study computer processes. Formal analysis and theorem proving methods to guarantee correctness of software programs have been of interest in many cases. When a computer program interacts with the real world, as it is the case in embedded systems, then in addition to discrete dynamics one must also consider continuous dynamics and so use hybrid system models. In such case, a particular path in the program may be followed based on the value of a continuous variable that represents continuous time or some other physical quantity described by say differential equations.

Formal analysis of hybrid systems is concerned with verifying whether the hybrid system satisfies desired specifications. These specifications could be safety specifications where it is important to guarantee that the states of the system avoid certain unsafe regions, for example verifying that the gate at a railroad crossing is never up when a train is coming, or certain valves in a chemical process are not open at particular critical stages as this may lead to a catastrophic explosion. The specifications could also be reachability specifications, where the interest is in the states of the system being able to reach certain other desirable states, as for example is the case during start up procedures for an electric power station.

Hybrid automata were introduced in the study of hybrid systems in the early 90s. They have provided a concrete mathematical framework, which is useful primarily for the analysis and the verification of hybrid systems. Figure 3 shows an example of a hybrid automaton that describes the operation of a simple home thermostat.

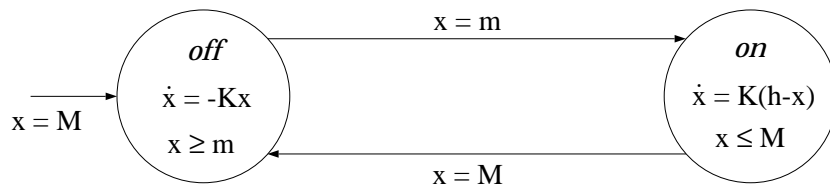

Figure 3: Hybrid automaton describing a thermostat.

A hybrid automaton consists of a finite automaton with continuous dynamics associated with each discrete state of the automaton that are typically modeled via differential equations or differential inclusions. At each discrete state there are initial conditions for the time and values of the continuous state, differential equations or inclusions that describe the flow of the continuous state, and invariants that describe regions of the continuous state space where the system stays at the discrete state. The transition from one discrete state to another is triggered by the satisfaction of certain guards, typically inequalities on the values of the continuous state. When a discrete transition occurs then assignments are made to the continuous state that act as initial conditions to the next discrete state. Note that the state of the hybrid automaton contains both the discrete and the continuous states and so it changes either by discrete jumps in the discrete state or through the continuous flow of the continuous state. In Figure 3, the system has two control modes *off* and *on*. When the heater is off the temperature of the room (denoted by the real valued variable x) is governed by the differential equation $\dot{x} = -Kx$ (flow condition). When the heater is on (control mode *on*) the temperature of the system evolves according to the flow condition $\dot{x} = K(h - x)$, where h is a constant. Logical formulas (guards) detect when the temperature crosses the thresholds m and M and trigger an appropriate control switching. Based on the type of continuous dynamics, there are several variations of hybrid automata. For example there are timed automata where the continuous dynamics in the N discrete states are all of the form $\dot{x} = 1$, rectangular hybrid automata where the flow relations for each continuous state is of the form $\dot{x} \in [a, b]$ and linear automata where the flow condition is of the form $\dot{x} = k$. Reachability

results exist for the simpler hybrid automata and good progress has been made in the cases of more general hybrid automata where results, although weaker already exist.

Because of mathematical complexity, computational or algorithmic approaches to the verification of hybrid systems are typically used and the aim is to verify in a finite number of steps whether the system satisfies a certain property. Decidability of the algorithm, which is the ability to give a yes or no answer in finite number of steps is a central issue, because of the uncountability of the hybrid state-space, as opposed to the case of discrete event systems where the state-space is typically finite. Semi-decidable algorithms where if the algorithm terminates in finite number of steps then the property may be guaranteed are sometimes used. Clearly, computational complexity is the issue here. One way to study which problems are decidable is to use abstracted discrete systems that describe the process and preserve the properties of interest. Abstractions are derived by constructing appropriate finite number of partitions of the state-space of the hybrid system. Checking the desired property on the abstracted discrete system could be either equivalent or just sufficient to checking the property on the original hybrid system.

Discrete abstractions of the hybrid dynamics are used in a hybrid automaton framework to address computational issues in checking properties such as reachability. It is interesting to note that discrete abstractions are also used to obtain discrete event system representations of the continuous dynamics for control purposes in a supervisory control of hybrid systems. There, a finite automaton or a Petri net DES model of the plant is obtained and methodologies from the theory of supervisory control of DES are used to control the hybrid system.

Other approaches to analysis and synthesis of hybrid systems have been developed primarily to address needs in specific classes of applications. In particular, optimization techniques from the area of mathematical programming, such as mixed integer programming, have been used in verification problems in chemical in hybrid processes. Discrete event system methodologies, such as the max-plus algebra approach, has been used in the analysis and design of hybrid systems that integrate task scheduling, action planning and control in robotic manufacturing systems. An optimal control problem that addresses a manufacturing problem, in particular to design a control strategy that trades off job completion deadlines against the quality of the completed jobs, is formulated and solved. In this case the formulation integrates both continuous, time-driven dynamics with discrete, event-driven dynamics.

Finally, it is very important to have good software tools for the simulation, analysis and design of hybrid systems, which by their nature are complex systems. Researchers have recognized this need and in several of the papers in the special issue special reference is made to such existing software packages.

SPECIAL ISSUE PAPERS

The papers of this special issue were selected with special care to present a view of the hybrid systems area that covers the main approaches with adequate detail, while providing at the same time appropriate breadth that are indicative of the breadth and depth of the field of hybrid systems. All the papers were invited and their authors represent research groups that are among the leading research groups in hybrid systems. The papers in this special issue provide a rather comprehensive description of the state of the art in hybrid systems. It should be reminded however that a special issue in the Proceedings of the IEEE can only include a limited number of papers, and so the approaches presented should be seen as representative research directions and approaches, and not as a complete and exhaustive list of all existing methods. There are thirteen papers in the Special Issue each of which passed through (at least two rounds) of full peer review. Below a brief description of each paper is given. The descriptions are arranged in the sequence the papers appear.

1) In "Automotive Engine Control and Hybrid Systems: Challenges and Opportunities," Balluchi et al. introduce hybrid models to more accurately represent time and event-based behaviors so to meet challenging design requirements in the design of engine control systems. They then develop a design methodology and they illustrate their approach on three problems: the fast transient control, the cut-off control and the idle speed control problem.

2) Horowitz and Varaiya in "Control Design of an Automated Highway System," describe the design of an Automated Highway System (AHS) developed over the past ten years at the California PATH program that required advances in the design, analysis, simulation, and testing of large-scale, hierarchical, hybrid control systems. The paper focuses on the multi-layer AHS control architecture and discusses in detail the design and safety verification of the on-board vehicle control system, and the design of the link layer traffic flow controller.

3) In "High-Level Modeling and Analysis of the Traffic Alert and Collision Avoidance System (TCAS)," Livadas et al. introduce high-level hybrid automata models of the closed-loop TCAS system (an avionics system that detects and resolves aircraft collision threats) for analysis and formal safety verification, that capture the behavior not only of the software, but also of the airplanes, sensors, pilots, etc. Note that due to the complexity of the TCAS software and the hybrid nature of the closed-loop system, the traditional testing technique of exhaustive simulation does not constitute a viable verification approach.

4) In "A Game Theoretic Approach to Controller Design for Hybrid Systems," Tomlin et al., derive feedback control laws which guarantee that the hybrid system remains in the safe subset of the reachable set of states. Their approach, that is based on optimal control and game theory for automata and continuous dynamical systems, is demonstrated on examples of hybrid automata modeling aircraft conflict resolution, autopilot fight mode switching, and vehicle collision avoidance.

5) Alur et al. in "Discrete Abstractions of Hybrid Systems," treat the problem of abstracting a system in a way that preserves all properties definable in temporal logic while hiding the details that are of no interest. The classes that permit discrete abstractions fall into two categories. Either the continuous dynamics must be severely restricted, as is the case for timed and rectangular hybrid systems, or the discrete dynamics must be severely restricted, as is the case for o-minimal hybrid systems. In this paper, the main results in both areas are surveyed and unified.

6) Davoren and Nerode in "Logics for Hybrid Systems," offer a synthetic overview of, and original contributions to the use of logics and formal methods in the analysis of hybrid systems. Note that the safety-critical nature of many of the application areas of hybrid systems has fostered a large and growing body of work on formal methods for hybrid systems: mathematical logics, computational models and methods, and computer-aided reasoning tools supporting the formal specification and verification of performance requirements for hybrid systems, and the design and synthesis of control programs for hybrid systems that are provably correct with respect to formal specifications.

7) In "Effective Synthesis of Switching Controllers for Linear Systems," Asarin et al. present a methodology for synthesizing switching controllers for the safe operation of systems described by linear differential equations. The approach is based on reachability analysis and the iterative computation of reachable states.

8) In "Supervisory Control of Hybrid Systems," Koutsoukos et al. first consider a functional architecture of hybrid control systems consisting of a continuous plant, a discrete-event controller and an interface, and discuss the interaction between the continuous and discrete dynamics which is a fundamental issue in any hybrid system studies. Discrete abstractions are then used to approximate the continuous plant. Properties for the discrete abstractions to be appropriate representations of the continuous plant are presented and supervisory control methodologies to satisfy control specifications described by formal languages are described.

9) In "Continuous-Discrete Interactions in Chemical Processing Plants," Engell et al., discuss important hybrid aspects of chemical processing plants. They first treat modeling and simulation for the design and optimization of plants, controllers and operating strategies and present simulation environments which have been developed in recent years. They discuss validation of plant instrumentation and discrete controllers and they describe techniques for the verification of discrete controllers for continuous processes which are based on a discrete approximation of the continuous dynamics. They also discuss scheduling of batch chemical process plants that lead to large mixed-integer optimization problems.

10) In "Perspectives and Results on the Stability and Stabilizability of Hybrid Systems," DeCarlo et al. survey the major results in the Lyapunov stability of finite dimensional hybrid systems and then discuss the stronger, more specialized results of switched linear (stable and unstable) systems. It is also shown how some of the results can be formulated in terms of linear matrix inequalities.

11) In "Performance Benefits of Hybrid Control Design for Linear and Nonlinear Systems," McClamroch

et al. provide an overview of recent developments in the design of hybrid controllers for continuous-time control systems that can be described by linear or nonlinear differential state equations. Hybrid controllers provide a generalization of classical feedback controllers for linear and nonlinear systems. The benefits of hybrid controllers are that they can be used to achieve closed loop performance objectives that cannot be achieved using classical linear or nonlinear controllers.

12) In "Integration of Task Scheduling, Action Planning and Control in Robotic Manufacturing Systems," Song et al. describe an approach that integrates low-level system sensing and control with high-level system behavior and perception. An event-based planning and control method is introduced and extended to a robotic manufacturing system via a hybrid system approach. A typical parts-sorting task in a robotic manufacturing system is used to illustrate the proposed approach.

13) Finally, in "Optimal Control of Hybrid Systems in Manufacturing," Pepyne and Cassandras introduce a hybrid system framework for manufacturing processes and point out that hybrid models that combine time-driven and event-driven dynamics provide a natural framework for such processes. They then discuss associated optimal control problems and show how the structure of the problem can be exploited to decompose what is a hard non-smooth, non-convex optimization problem into a collection of simpler problems.

In closing, it is hoped that this special issue will shed some light into the very challenging, but at the same time highly promising area of hybrid systems and by doing so will encourage and energize more scientists and engineers to assume an active role in shaping its future. In view of the ever increasing demands of our society for high performance, highly complex engineering systems, all indications are that hybrid systems represent the future and it is expected that they will be assuming a leading role in systems theory and applications, as digital systems dominated the second half of the 20th century taking the leading role from analog systems.

ACKNOWLEDGEMENTS

The Guest Editor would like to thank Jim Calder, Managing Editor of the Proceedings of the IEEE for his help, encouragement and support. Special thanks go to all contributors and reviewers who really made this special issue a reality. Thank you all for your helpful comments, prompt responses and excellent insights and expertise.

REFERENCES

[1] R. L. Grossman, A. Nerode, A. P. Ravn and H. Rischel, (eds), Hybrid Systems, Lecture Notes in Computer Science, Vol. 736, Springer-Verlag, 1993.

- [2] P. Antsaklis, W. Kohn, A. Nerode, and S. Sastry, (eds), Hybrid Systems II, P. Antsaklis, W. Kohn, A. Nerode, and S. Sastry, (eds), Lecture Notes in Computer Science, Vol.999, Springer-Verlag, 1995.
- [3] R. Alur, T. Henzinger, and E. Sontag, (eds), Hybrid Systems III-Verification and Control, Lecture Notes in Computer Science, Vol., Springer-Verlag, 1996.
- [4] P. Antsaklis, W. Kohn, A. Nerode, and S. Sastry, (eds), Hybrid Systems IV, Lecture Notes in Computer Science, Vol. 1273, Springer-Verlag, 1997.
- [5] P. Antsaklis, W. Kohn, M. Lemmon, A. Nerode, and S. Sastry, (eds), Hybrid Systems V, Lecture Notes in Computer Science, Vol. 1567, Springer-Verlag, 1999.
- [6] T. Henzinger, and S. Sastry, (eds), Hybrid Systems: Computation and Control, Lecture Notes in Computer Science, Vol. 1386, Springer-Verlag, 1998.
- [7] F. Vaandrager and J. van Schuppen (eds), Hybrid Systems: Computation and Control, Lecture Notes in Computer Science, Vol. 1569, Springer-Verlag, 1999.
- [8] B. Krogh and N. Lynch, (eds), Hybrid Systems: Computation and Control, Lecture Notes in Computer Science, Vol. 1790, Springer-Verlag, 2000.
- [9] O. Maler, (ed.), Hybrid and Real-Time Systems, Lecture Notes in Computer Science, Vol. 1201, Springer-Verlag, 1997.
- [10] A.S.Morse, (ed.), Control Using Logic-Based Switching, Lecture Notes in Control and Information Systems, Vol. 222, Springer-Verlag, 1996.
- [11] A.S. Matveev and A.V. Savkin, Qualitative Theory of Hybrid Dynamical Systems, Birkhauser, 2000.
- [12] Special Issue on Hybrid Control Systems, P.J. Antsaklis and A. Nerode Guest Editors, IEEE Transactions on Automatic Control, Vol. 43, No. 4, April 1998.
- [13] Special Issue on Hybrid Systems, P.J. Antsaklis and M.D. Lemmon. Guest Editors, Journal of Discrete Event Dynamic Systems: Theory and Applications, Vol. 8, No.2, June 1998.
- [14] Special Issue on Hybrid Systems, J. Sifakis and A. Pnueli, Guest Editors, Journal of Theoretical Computer Science, vol 138, 1995.
- [15] Special Issue on Hybrid Systems, A. Morse, C. Pantelides, S. Sastry and J. Schumacher, Guest Editors, Automatica, Vol.35, 1999.
- [16] Special Issue on Hybrid Control Systems, R. Evans and A.V. Savkin, Guest Editors, Systems and Control Letters, Vol.38,1999.
- [17] M.D. Lemmon, K.X. He and I. Markovskiy, "Supervisory Hybrid Systems," Control Systems, Vol. 19, No. 4, pp. 42-55, August 1999.
- [18] P.J. Antsaklis, X. Koutsoukos, and J. Zaytoon, "On Hybrid Control of Complex Systems: A survey,"

European Journal of Automation, Vol.32, No.9-10, pp. 1023-1045, 1998.

[19] P.J. Antsaklis, "Defining Intelligent Control," Report of the IEEE CSS Task Force on Intelligent Control, IEEE Control Systems, pages 4-5 & 58-66, June 1994.

[20] P.J. Antsaklis and K.M. Passino, (eds.), An Introduction to Intelligent and Autonomous Control, Kluwer Academic Publishers, 1993. [21] K.J. Astrom, and B. Wittenmark, Computer-Controlled Systems: Theory and Design, Prentice Hall, 1997.

[22] T. Chen and B. Francis, Optimal Sampled-Data Control Systems, Communications and Control Engineering Series, Springer-Verlag, 1996. [23] A.V. Oppenheim, A.S. Willsky and S.H. Nawab, Signals and Systems, Prentice Hall, 1997.

[24] P.J. Antsaklis and A.N. Michel, Linear Systems, McGraw-Hill. 1997.

[25] H.K. Khalil, Nonlinear Systems, Prentice Hall, 1996.

[26] C.G. Cassandras and S. Lafortune, Introduction to Discrete Event Systems, Kluwer Academic Publishers, 1999.

[27] H. S. Witsenhausen, "A class of hybrid-state continuous-time dynamic systems," IEEE Trans. on Automatic Control, vol. 11, no. 2, pp. 161-167, Febr. 1966.

[28] L. Tavernini, "Differential automata and their discrete simulators," Nonlinear Anal., Theory, Methods, and Appl., vol. 11, no. 6, pp. 665-683, 1987.

[29] A. F. Filippov, Differential Equations with Discontinuous Right Hand Sides, Kluwer Academic Publishers, 1988.

[30] M. Branicky, V. Borkar, and S. Mitter, "A Unified Framework for Hybrid Control: Model and Optimal Control Theory," IEEE Transactions on Automatic Control, Vol. 43, No. 1, pp. 31-45, Jan. 1998.

[31] R.E. Kalman, P.L. Falb and M.A. Arbib, Topics in Mathematical System Theory, McGraw-Hill, 1969.

[32] G.F. Franklin, J.D. Powell and A. Emami-Naeini, Feedback Control of Dynamic Systems, Addison Wesley Longman, 1994.

[33] Special Issue on the Dynamics of Discrete Event Systems, Y.-C. Ho (ed.), Proceedings of the IEEE, January 1989.

[34] C. M. Ozveren, A. S. Willsky and P. J. Antsaklis, "Stability and Stabilizability of Discrete Event Dynamic Systems," Journal of the Association of Computing Machinery, Vol 38, No 3, pp 730-752, 1991.

[35] K. M. Passino, A. N. Michel and P. J. Antsaklis, "Lyapunov Stability of a Class of Discrete Event Systems," IEEE Trans. Automatic Control, Vol.39, No.2, pp 269-279, February 1994; correction, p 1531, July 1994.

[36] K. M. Passino and P. J. Antsaklis, "A System and Control Theoretic Perspective on Artificial Intelligence

Planning Systems," Applied Artificial Intelligence, Vol. 3, pp. 1-32, 1989.

[37] T.L. Dean and M. P. Wellman, Planning and Control, Morgan Kaufman, San Mateo, California, 1991.

[38] J.O. Moody and P.J. Antsaklis, Supervisory Control of Discrete Event Systems using Petri Nets, Kluwer Academic Publishers, June 1998.

[39] A. N. Michel, "Recent trends in the stability analysis of hybrid dynamical systems," IEEE Trans. Circuits and Systems I, vol. 46, No. 1, pp. 120-134, Jan. 1999.

[40] M. Branicky, "Multiple Lyapunov Functions and Other Analysis Tools for Switched and Hybrid Systems," IEEE Transactions on Automatic Control, Vol. 43, No. 4, pp. 475-482, April 1998.

Panos Antsaklis, Guest Editor

Department of Electrical Engineering

University of Notre Dame

Notre Dame, IN 46556