

Math 10270 Final, May 6th, 09. NAME (10 pts.): _____

Please Note: *Calculators may be used only in elementary computational mode. Please note also that for your solutions to receive full credit, they must be complete, precisely formulated, and cast in a well organized, legible way.*

1. (15 pts.) What is the principle limitation of stone beam and column construction? Describe the underlying reason by considering the consequences of the forces on the beam and the structural properties of stone. Illustrate with a diagram.

2. (20 pts) The keystone of a Roman arch is depicted below. It weighs 400 pounds. Use this information and the diagram to compute the upward slanting push P from each of the two voussoirs (below the keystone) that is required to keep the voussoir in place. (As is done in the text, ignore friction.) Use this information to compute the outward horizontal force that the keystone generates in each direction.

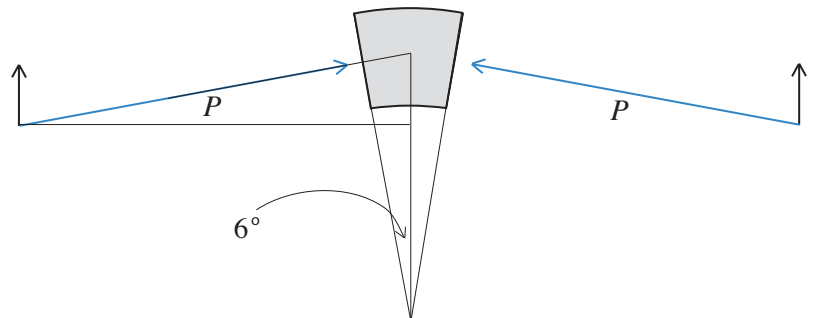

3. (15 pts.) Explain what hoopstress is, what causes it, and what structural problems it causes in a dome. Illustrate with a diagram.

4. (20 pts.) Describe the structural scheme (along with its components) of a typical Gothic cathedral by discussing the vaults over the nave and how the substantial weight of these vaults is transferred to the ground. Illustrate with diagrams.

5. (15 pts.) The figure below depicts a pointed *quinto acuto* arch in the coordinate plane.

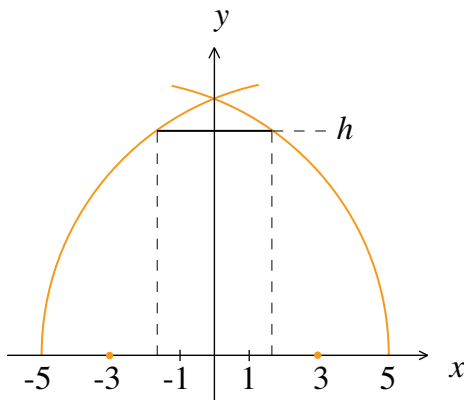

What are the centers and the radii of the circles on which the two arches lie? Use the equations of these circles to determine the height of the arch.

6. (25 pts.) A square with center C is given. Its vertices are labeled 1 through 4. Is the transformation T given numerically by $\begin{pmatrix} 1 & 2 & 3 & 4 \\ 2 & 1 & 4 & 3 \end{pmatrix}$ a rotation or a reflection of the square? Describe the action of T on the square.

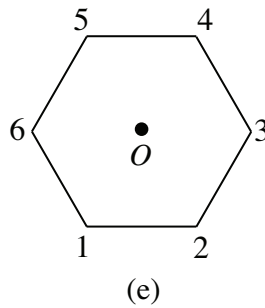
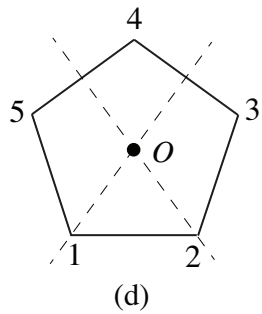
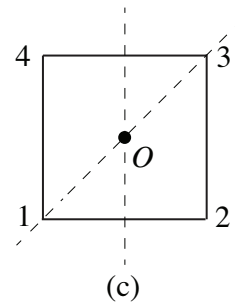
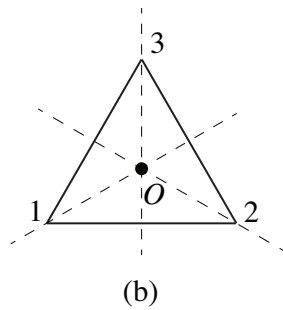
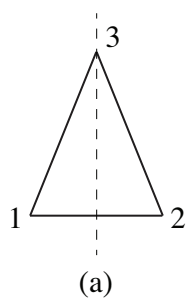

Determine numerically the transformation R obtained by rotating the square clockwise by 90° . Then determine numerically the transformation obtained by following R by T and describe how this transformation acts on the square.

List all eight *symmetry transformations* of the square using the numerical notation. Include the identity transformation, rotations and reflections.

7. (20 pts.) Describe Michelangelo's most important contributions to the design of Saint Peter's.

8. (15 pts.) Consider $f(x) = \frac{1}{x^2}$. Use the *limit definition* of the derivative to show that $f'(x) = -\frac{2}{x^3}$.

9. (25 pts.) Consider the function $f(x) = 9 - x^2$ with $0 \leq x \leq 3$.

i. Take $n = 6$ and compute the sum that arises in the definition of the integral $\int_0^3 (9 - x^2) dx$. Do so with two decimal place accuracy.

ii. Why is this sum only a rough approximation of $\int_0^3 (9 - x^2) dx$?

iii. Use the Fundamental Theorem of Calculus to find the precise value of this integral.

iv. Sketch the area that you computed in iii.

10. (20 pts.) Use the strategy of calculus in combination with the Fundamental Theorem of Calculus to compute the volume of a cone of height h and base of radius r . [Make use of the figure.]

